



YAMAHA

2005

TDM900A(T)

5PS1-AE4

**SUPPLEMENTARY
SERVICE MANUAL**

FOREWORD

This Supplementary Service Manual has been prepared to introduce new service and data for the TDM900A(T) 2005. For complete service information procedures it is necessary to use this Supplementary Service Manual together with the following manual.

TDM900(N) 2001 SERVICE MANUAL: 5PS1-AE1
TDM900(R) 2003 SUPPLEMENTARY SERVICE MANUAL: 5PS1-AE2
TDM900(S) 2004 SUPPLEMENTARY SERVICE MANUAL: 5PS1-AE3

**TDM900A(T) 2005
SUPPLEMENTARY
SERVICE MANUAL**
©2004 by Yamaha Motor Co., Ltd.
First Edition, December 2004
All rights reserved.
Any reproduction or unauthorized use
without the written permission of
Yamaha Motor Co., Ltd.
is expressly prohibited.

NOTICE

This manual was produced by the Yamaha Motor Company, Ltd. primarily for use by Yamaha dealers and their qualified mechanics. It is not possible to include all the knowledge of a mechanic in one manual. Therefore, anyone who uses this book to perform maintenance and repairs on Yamaha vehicles should have a basic understanding of mechanics and the techniques to repair these types of vehicles. Repair and maintenance work attempted by anyone without this knowledge is likely to render the vehicle unsafe and unfit for use.

Yamaha Motor Company, Ltd. is continually striving to improve all its models. Modifications and significant changes in specifications or procedures will be forwarded to all authorized Yamaha dealers and will appear in future editions of this manual where applicable.

NOTE:

Designs and specifications are subject to change without notice.

IMPORTANT INFORMATION

Particularly important information is distinguished in this manual by the following.



The Safety Alert Symbol means ATTENTION! BECOME ALERT! YOUR SAFETY IS INVOLVED!



Failure to follow WARNING instructions could result in severe injury or death to the motorcycle operator, a bystander or a person checking or repairing the motorcycle.

CAUTION:

A CAUTION indicates special precautions that must be taken to avoid damage to the motorcycle.

NOTE:

A NOTE provides key information to make procedures easier or clearer.

HOW TO USE THIS MANUAL

This manual is intended as a handy, easy-to-read reference book for the mechanic. Comprehensive explanations of all installation, removal, disassembly, assembly, repair and check procedures are laid out with the individual steps in sequential order.

- ① The manual is divided into chapters. An abbreviation and symbol in the upper right corner of each page indicate the current chapter. Refer to "SYMBOLS".
- ② Each chapter is divided into sections. The current section title is shown at the top of each page, except in Chapter 3 ("PERIODIC CHECKS AND ADJUSTMENTS"), where the sub-section title(s) appears.
- ③ Sub-section titles appear in smaller print than the section title.
- ④ To help identify parts and clarify procedure steps, there are exploded diagrams at the start of each removal and disassembly section.
- ⑤ Numbers are given in the order of the jobs in the exploded diagram. A circled number indicates a disassembly step.
- ⑥ Symbols indicate parts to be lubricated or replaced. Refer to "SYMBOLS".
- ⑦ A job instruction chart accompanies the exploded diagram, providing the order of jobs, names of parts, notes in jobs, etc.
- ⑧ Jobs requiring more information (such as special tools and technical data) are described sequentially.

CLUTCH ENG

CLUTCH

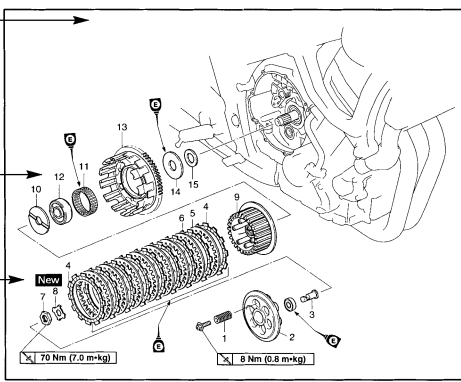

④ →

⑤ →

⑥ →

⑦ →

| Order | Job/Part | Qty | Remarks |
|----------------------------|------------------|-----|---------------------------------------|
| Removing the clutch | | | |
| 1 | Clutch spring | 6 | Remove the parts in the order listed. |
| 2 | Pressure plate | 1 | |
| 3 | Pull rod | 1 | |
| 4 | Friction plate 1 | 2 | |
| 5 | Clutch plate | 8 | |
| 6 | Friction plate 2 | 7 | |
| 7 | Nut | 1 | |
| 8 | Lock washer | 1 | |
| 9 | Clutch boss | 1 | |
| 10 | Thrust plate | 1 | |
| 11 | Bearing | 1 | |
| 12 | Spacer | 1 | |
| 13 | Clutch housing | 1 | |

5-42

CLUTCH ENG

CLUTCH

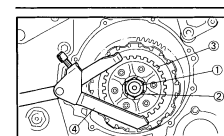

③ →

REMOVING THE CLUTCH

- Straighten the lock washer tab.
- Loosen:
 - clutch boss nut ①

NOTE:
While holding the clutch boss ③ with the universal clutch holder ⑧, loosen the clutch boss nut.

Universal clutch holder
90890-04086

- Remove:
 - lock washer ②
 - Clutch boss ③

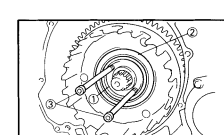

⑧ →

- Remove:
 - spacer ①
 - bearing ②

NOTE:
Insert two 6-mm bolts ③ into the spacer and then remove the spacer by pulling on the bolts.

5-44

CHECKING THE FRICTION PLATES

The following procedure applies to all of the friction plates:







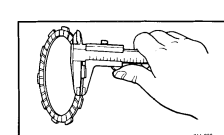









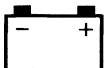

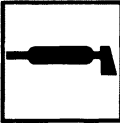

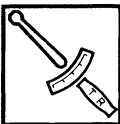
- Check:
 - friction plate
Damage/wear → Replace the friction plates as a set.
- Measure:
 - friction plate thickness
Out of specification → Replace the friction plates as a set.

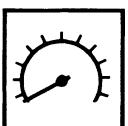
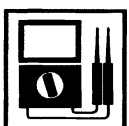
NOTE:
Measure the friction plate at four places.

Friction plate thickness
2.9 – 3.1 mm
◀Limit: 2.8 mm



211 006

| | | |
|--|---|---|
| ① GEN INFO  | ② SPEC  | |
| ③ CHK ADJ  | ④ CHAS  | |
| ⑤ ENG  | ⑥ COOL  | |
| ⑦ FI  | ⑧ ELEC  | |
| ⑨ TRBL SHTG ? | ⑩  | |
| ⑪  | ⑫  | |
| ⑬  | ⑭  | |
| ⑮  | ⑯  | ⑰  |
| ⑱  | ⑲  | ⑳  |
| ㉑  | ㉒  | ㉓  |
| ㉔  | ㉕ New | |

EAS00008

SYMBOLS

The following symbols are not relevant to every vehicle.

Symbols ① to ⑨ indicate the subject of each chapter.

- ① General information
- ② Specifications
- ③ Periodic checks and adjustments
- ④ Chassis
- ⑤ Engine
- ⑥ Cooling system
- ⑦ Fuel injection system
- ⑧ Electrical system
- ⑨ Troubleshooting

Symbols ⑩ to ⑰ indicate the following.

- ⑩ Serviceable with engine mounted
- ⑪ Filling fluid
- ⑫ Lubricant
- ⑬ Special tool
- ⑭ Tightening torque
- ⑮ Wear limit, clearance
- ⑯ Engine speed
- ⑰ Electrical data

Symbols ⑱ to ㉓ in the exploded diagrams indicate the types of lubricants and lubrication points.

- ⑱ Engine oil
- ⑲ Gear oil
- ⑳ Molybdenum-disulfide oil
- ㉑ Wheel-bearing grease
- ㉒ Lithium-soap-based grease
- ㉓ Molybdenum-disulfide grease

Symbols ㉔ to ㉕ in the exploded diagrams indicate the following.

- ㉔ Apply locking agent (LOCTITE®)
- ㉕ Replace the part

CONTENTS

GENERAL INFORMATION

| | |
|-------------------------------|---|
| FEATURES | 1 |
| INSTRUMENT PANEL | 1 |
| SPECIAL TOOLS | 4 |

SPECIFICATIONS

| | |
|--|----|
| GENERAL SPECIFICATIONS | 5 |
| ENGINE SPECIFICATIONS | 5 |
| CHASSIS SPECIFICATIONS | 5 |
| ELECTRICAL SPECIFICATIONS | 6 |
| TIGHTENING TORQUES | 7 |
| CHASSIS TIGHTENING TORQUES | 7 |
| CABLE ROUTING | 8 |
| SWINGARM AND DRIVE CHAIN | 28 |
| CHECKING THE DRIVE CHAIN | 28 |
| ANTI-LOCK BRAKE SYSTEM (ABS) | 30 |
| ABS OUTLINE | 30 |
| ABS | 31 |
| ABS COMPONENTS | 49 |
| FRONT WHEEL SENSOR AND SENSOR ROTOR | 50 |
| REAR WHEEL SENSOR AND SENSOR ROTOR | 54 |
| HYDRAULIC UNIT | 57 |
| HYDRAULIC ABS | 64 |
| CHECKING THE RESERVOIR TANK FLUID LEVEL | 73 |
| TRIAL RUN | 73 |

ELECTRICAL

| | |
|--|----|
| ELECTRICAL COMPONENTS | 74 |
| CHECKING THE SWITCHES | 76 |
| ELECTRIC STARTING SYSTEM | 77 |
| CIRCUIT DIAGRAM | 77 |
| STARTING CIRCUIT CUT-OFF SYSTEM OPERATION | 78 |
| TROUBLESHOOTING | 79 |
| SIGNALING SYSTEM | 83 |
| CIRCUIT DIAGRAM | 83 |
| TROUBLESHOOTING | 85 |
| CHECKING THE SIGNAL SYSTEM | 86 |

| | |
|---|-----|
| ANTI-LOCK BRAKE SYSTEM (ABS) | 94 |
| CIRCUIT DIAGRAM..... | 94 |
| ABS COMPONENTS..... | 96 |
| ABS CONNECTOR LOCATION CHART..... | 97 |
| ECU (ABS) AND FAIL-SAFE RELAY | 98 |
| TROUBLESHOOTING..... | 103 |
| CHECKING THE ANTI-LOCK BRAKE SYSTEM..... | 104 |
| TROUBLESHOOTING BY THE SELF DIAGNOSIS | 107 |
| MALFUNCTION CHECK BY THE ABS SELF DIAGNOSIS (PAST MALFUNCTION) | 107 |
| MALFUNCTION CHECK BY THE ABS SELF DIAGNOSIS (PRESENT MALFUNCTION)..... | 108 |
| DELETING THE MALFUNCTION CODE | 120 |

TROUBLESHOOTING

| | |
|---|-----|
| ANTI-LOCK BRAKE SYSTEM (ABS) | 122 |
| ABS TROUBLESHOOTING OUTLINE | 122 |
| BASIC INSTRUCTION FOR TROUBLESHOOTING..... | 123 |
| BASIC PROCESS FOR TROUBLESHOOTING | 124 |
| TROUBLESHOOTING AT THE ABS WARNING LIGHT | 125 |
| ONLY THE ABS WARNING LIGHT DOES NOT COME ON. | 125 |
| ALL INDICATORS DO NOT COME ON..... | 125 |
| ABS WARNING LIGHT CONTINUES TO FLASHES..... | 125 |
| ABS WARNING LIGHT FLASHES EVERY 0.5 SECONDS..... | 125 |
| ABS WARNING LIGHT CONTINUES TO COME ON. | 125 |

TDM900A(T) 2005 WIRING DIAGRAM

GENERAL INFORMATION

FEATURES

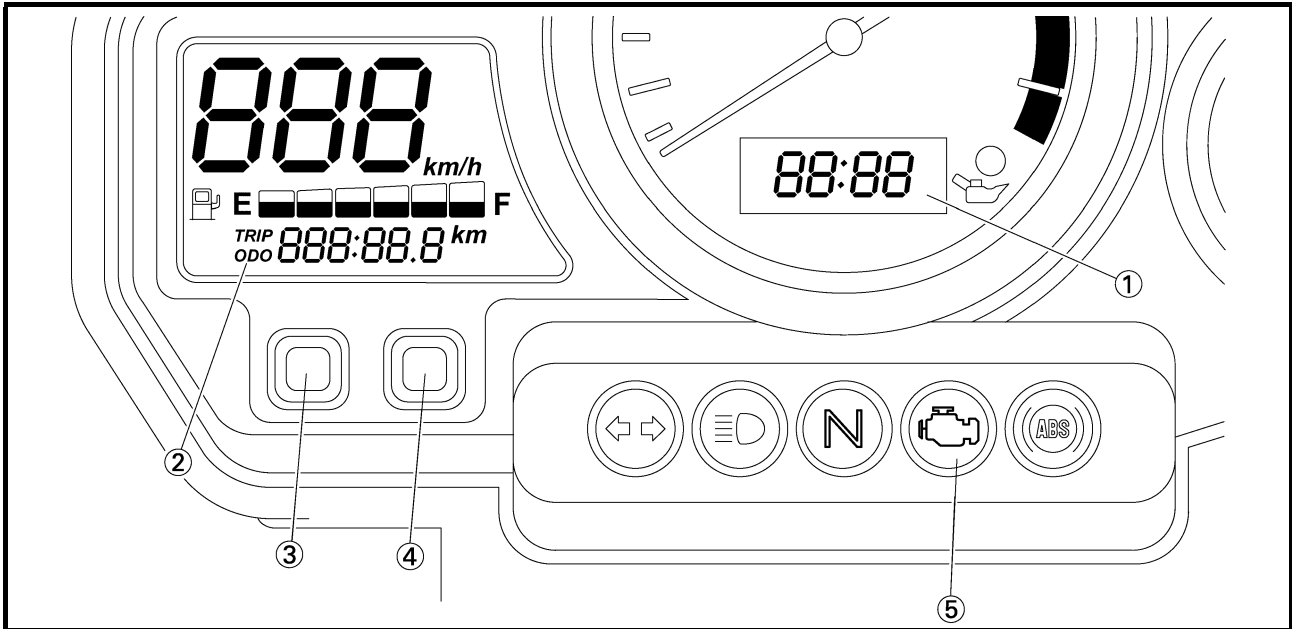

INSTRUMENT PANEL



- ① Clock
- ② TRIP/ODO meter
- ③ SELECT button
- ④ RESET button
- ⑤ Engine trouble warning light

Function indication

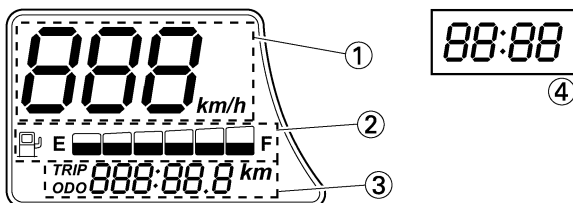
The indications of the self-diagnosis function can be checked and inspection operations can be performed through the use of the multi-function meter on the instrument panel. Based on the signals received from the sensors, the ECU inputs the signals into the multi-function meter. Then, the conditions of the sensors appear on the clock and trip/odometer display of the multi-function meter.

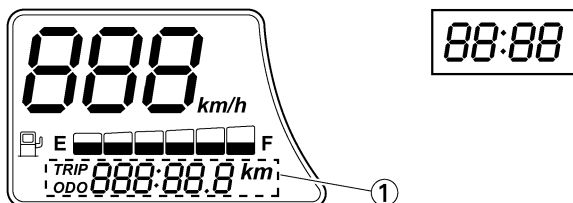
| | |
|--|---|
| <p>NORMAL MODE</p>  | <ul style="list-style-type: none"> ① Speed meter ② Fuel meter (The symbol “” blinks when the gasoline is almost empty) ③ Trip/odometer display ④ Clock display |
| <p>CO ADJUSTMENT/DIAGNOSTIC MONITORING SELECTION MODE</p>  | <ul style="list-style-type: none"> ① Temporary selection display for CO/DIAG. <p>CO: <i>TRIP</i> 888.8 km <i>ODO</i> 888.8 km</p> <p>DIAG: <i>TRIP</i> 888.8 km <i>ODO</i> 888.8 km</p> |



| | |
|--|---|
| <p>CO ADJUSTMENT MODE</p> | <p>① Cylinder identification For #1 For #2</p> <p style="text-align: center;">88 88</p> <p>② CO data Example: 8:88.8 8:88.8</p> <p style="text-align: center;">lean rich -128 ← 0 → 128</p> |
| <p>DIAGNOSTIC MONITORING MODE</p> | <p>① Diagnostic monitoring code Example: code "01"</p> <p style="text-align: center;">888</p> <p>② Monitoring data</p> |
| <p>WHEN THE COMMUNICATION ERROR OCCURRED BETWEEN ECU AND METER:</p> | <p>① Error code Example: When the error code is "Er-1"</p> <p style="text-align: center;">888:88.8</p> <p>For details of error codes, refer to "FAIL-SAFE ACTION TABLE" in chapter 7. (Manual No.: 5PS1-AE1)</p> |
| | <p>CAUTION: _____</p> <p>If the display ① shown in the illustration to the left appears, the multi-function display is malfunctioning. Replace the meter assembly.</p> <p>_____</p> |
| | <p>CAUTION: _____</p> <p>If the fuel meter does not display the fuel level, but repeatedly flashes as shown in the illustration, the fuel level monitoring system is malfunctioning. Check the fuel sender and the electrical circuit.</p> <p>_____</p> |

CO adjustment and diagnostic monitoring mode

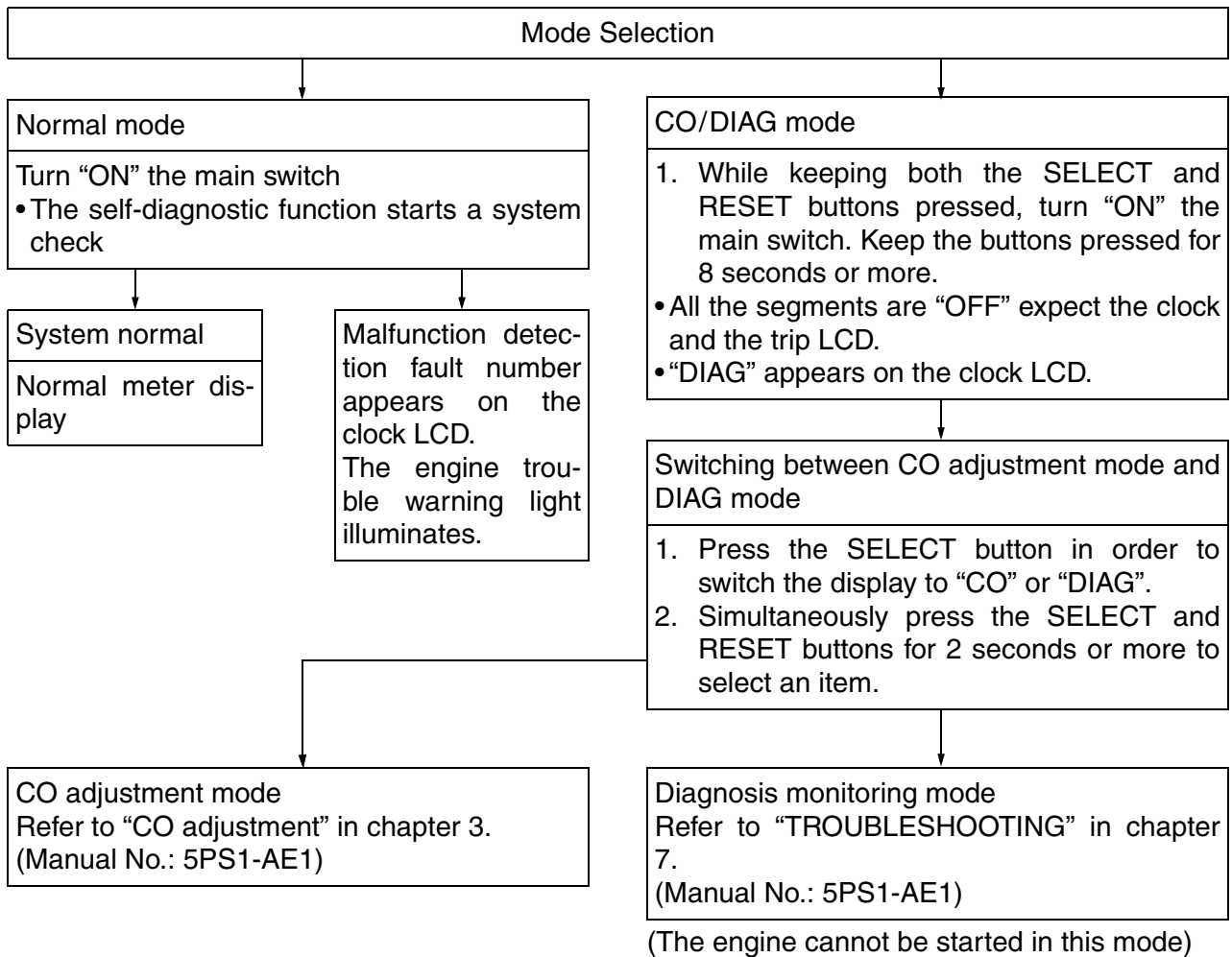

EB104000

SPECIAL TOOLS

The following special tools are necessary for complete and accurate tune-up and assembly. Use only the appropriate special tools as this will help prevent damage caused by the use of inappropriate tools or improvised techniques.

When placing an order, refer to the list provided below to avoid any mistakes.

| Tool No. | Tool name/Function | Illustration |
|-------------|---|---|
| 90890-03149 | Test coupler adaptor This tool is used to check the ABS diagnosis. |  |

SPECIFICATIONS

GENERAL SPECIFICATIONS

| Item | Standard | Limit |
|--|-----------------|-------|
| Model code | 2B01 (EUR) | ••• |
| Weight | | |
| Wet (with oil and a full fuel tank) | 224 kg (494 lb) | ••• |
| Dry (without oil and fuel) | 193 kg (426 lb) | ••• |
| Maximum load (total of cargo, rider, passenger, and accessories) | 200 kg (441 lb) | ••• |

ENGINE SPECIFICATIONS

| Item | Standard | Limit |
|---------------------------------|--------------------|-------|
| Throttle bodies | | |
| Model (manufacturer) × quantity | 38EIS (MIKUNI) × 2 | ••• |
| ID mark | 5PS1 11 | ••• |

CHASSIS SPECIFICATIONS

| Item | Standard | Limit |
|-------------------------|---|-----------------------|
| Front tire | | |
| Tire type | Tubeless | ••• |
| Size | 120/70ZR 18M/C (59W) | ••• |
| Model (manufacturer) | D220FSTJ (DUNLOP) | ••• |
| Tire pressure (cold) | | |
| 0 ~ 90 kg | 225 kPa (2.25 kgf/cm ² , 2.25 bar, 32 psi) | ••• |
| 90 ~ 200 kg | 225 kPa (2.25 kgf/cm ² , 2.25 bar, 32 psi) | ••• |
| High-speed riding | 225 kPa (2.25 kgf/cm ² , 2.25 bar, 32 psi) | ••• |
| Min. tire tread depth | ••• | 1.6 mm (0.06 in) |
| Rear tire | | |
| Tire type | Tubeless | ••• |
| Size | 160/60ZR 17M/C (69W) | ••• |
| Model (manufacturer) | D220STJ (DUNLOP) | ••• |
| Tire pressure (cold) | | |
| 0 ~ 90 kg | 250 kPa (2.5 kgf/cm ² , 2.5 bar, 35.6 psi) | ••• |
| 90 ~ 200 kg | 290 kPa (2.9 kgf/cm ² , 2.9 bar, 41.3 psi) | ••• |
| High-speed riding | 250 kPa (2.5 kgf/cm ² , 2.5 bar, 35.6 psi) | ••• |
| Min. tire tread depth | ••• | 1.6 mm (0.06 in) |
| Drive chain: | | |
| Type (manufacturer) | DID525HV KAI (DAIDO) | ••• |
| Link quantity | 118 | ••• |
| Drive chain slack | 50 ~ 60 mm | ••• |
| Maximum 15-link section | ••• | 239.3 mm (9.42 in) |



ELECTRICAL SPECIFICATIONS









| Item | Standard | Limit |
|--|--|-------|
| Ignition system | | |
| Ignition system type | Transistorized coil ignition (digital) | ... |
| Ignition timing | 10° BTDC at 1,150 r/min | ... |
| Advancer type | Electric | ... |
| Pickup coil resistance/color | 192 ~ 288 Ω/L/Y-G/W | ... |
| Transistorized coil ignition unit model (manufacturer) | TBDF15 (DENSO) | ... |
| Indicator light (voltage/wattage × quantity) | | |
| Turn signal indicator light | 14 V 1.2 W × 1 | ... |
| ABS warning light | 14 V 1.4 W × 1 | ... |
| Starter relay | | |
| Model (manufacturer) | MS5F-631 (JIDECO) | ... |
| Amperage | 180 A | ... |
| Coil resistance | 4.18 ~ 4.62 Ω | ... |
| Front wheel sensor | | |
| Model (manufacturer) | OELABW (SUMITOMO) | ... |
| Resistance | 1.2 ~ 1.6 kΩ at 20°C | ... |
| Rear wheel sensor | | |
| Model (manufacturer) | OELABX (SUMITOMO) | ... |
| Resistance | 1.2 ~ 1.6 kΩ at 20°C | ... |
| Fail-safe relay | | |
| Model (manufacturer) | G8R-40Y (OMRON) | ... |
| Fuses (amperage × quantity) | | |
| Main fuse | 40 A × 1 | ... |
| Fuel injection system fuse | 10 A × 1 | ... |
| Headlight fuse | 20 A × 1 | ... |
| Signaling system fuse | 10 A × 1 | ... |
| Ignition fuse | 10 A × 1 | ... |
| Radiator fan motor fuse | 20 A × 1 | ... |
| Hazard light fuse | 10 A × 1 | ... |
| Backup fuse | 10 A × 1 | ... |
| ABS fuse | 10 A × 1 | ... |
| ABS motor fuse | 30 A × 1 | ... |
| Reserve fuse | 20 A × 1 | ... |
| | 10 A × 1 | ... |

TIGHTENING TORQUES

SPEC



TIGHTENING TORQUES CHASSIS TIGHTENING TORQUES

| Part to be tightened | Thread size | Tightening torque | | | Remarks |
|--|-------------|-------------------|------|-------|---|
| | | Nm | m•kg | ft•lb | |
| Lower bracket pinch bolt | M8 | 23 | 2.3 | 16.6 |  |
| Upper bracket and wire guide | M6 | 7 | 0.7 | 5.1 | |
| Throttle cable adjusting nut | M6 | 5 | 0.5 | 3.6 | |
| Engine mounting: | | | | |        |
| Rear upper mounting bolt and nut | M10 | 45 | 4.5 | 32.5 | |
| Rear lower mounting bolt and nut | M10 | 45 | 4.5 | 32.5 | |
| Pinch bolt | M8 | 26 | 2.6 | 18.8 | |
| Frame and rear frame | M10 | 41 | 4.1 | 29.7 | |
| Sidestand and sidestand bracket | M8 | 23 | 2.3 | 16.6 | |
| Sidestand bracket and frame | M8 | 26 | 2.6 | 18.8 | |
| Rear footrest and footrest bracket | M6 | 9 | 0.9 | 6.5 | |
| Front wheel sensor and sensor housing | M8 | 30 | 3.0 | 22 | |
| Rear wheel sensor and sensor housing | M8 | 30 | 3.0 | 22 | |
| Hydraulic unit and hydraulic unit bracket | M8 | 16 | 1.6 | 12 | |
| Hydraulic unit bracket and frame | M8 | 16 | 1.6 | 12 | |
| Hydraulic unit and brake hose | M10 | 30 | 3.0 | 22 | |
| Front brake hose holder and front brake hose | M6 | 10 | 1.0 | 7.2 | |
| Rear brake hose holder and rear brake hose | M6 | 7 | 0.7 | 5.0 | |
| Frame and connector plate | M5 | 7 | 0.7 | 5.0 | |
| Frame and brake hose holder | M6 | 10 | 1.0 | 7.2 | |



CABLE ROUTING

- ① Throttle cables
- ② Clutch cable
- ③ Left handlebar switch lead
- ④ Main switch lead and immobilizer lead
- ⑤ Cover 7
- ⑥ Horn lead
- ⑦ Horn
- ⑧ Front wheel sensor lead
- ⑨ Front brake hose (OUT)
- ⑩ Cover 8
- ⑪ Front brake hose (IN)
- ⑫ Right handlebar switch lead
- ⑬ Front fork
- ⑭ Clamp
- ⑮ Front turn signal light (right)
- ⑯ Headlight sub-wire harness
- ⑰ Indicator light lead
- ⑱ Stay 3
- ⑲ Front turn signal light (left)
- ⑳ Meter lead
- ㉑ Indicator light
- ㉒ Meter
- ㉓ Stay 1
- ㉔ Headlight coupler
- ㉕ Headlight adjusting knob

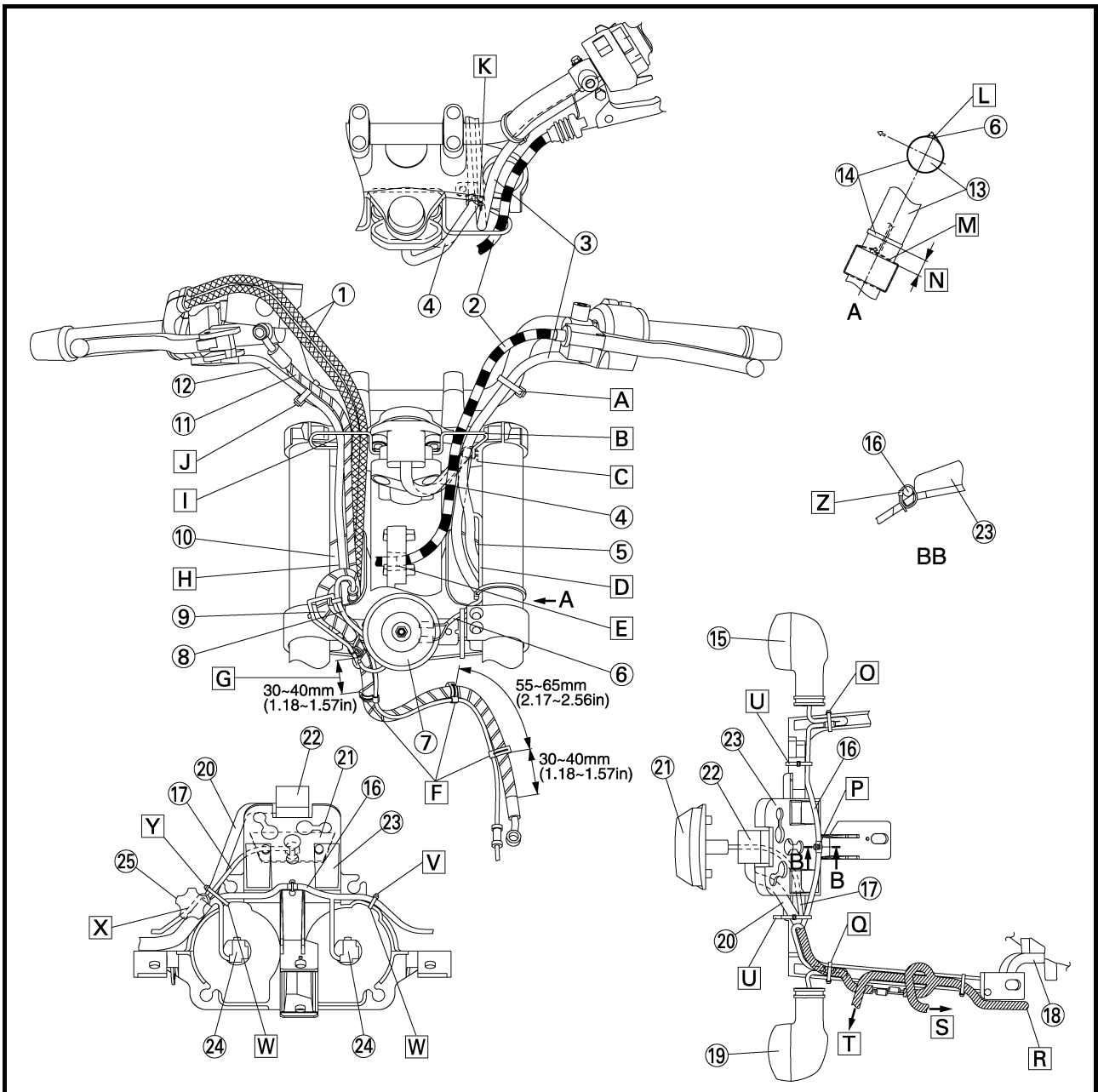

CABLE ROUTING

SPEC



- A** Fasten the left handlebar switch lead to the handlebar with a band.
- B** Through the left handlebar switch lead and clutch cable to the wire guide on the upper bracket.
- C** Fasten the main switch lead and immobilizer lead to the wire guide with a clamp. There should be no slack between main switch and wire guide. Cut the clamp tip leaving 3 ~ 8 mm (0.12 ~ 0.31 in).
- D** Route the main switch lead through the cover 7 so that it route beneath the left handlebar switch lead.
- E** Route the clutch cable through the hole in front of the head pipe on the frame.
- F** Route the front wheel sensor lead along the brake hose and clamp it at the position shown the drawing.
- G** It should be 30 ~ 40 mm (1.18 ~ 1.57 in) from the lower end of the grommet of the brake hose.
- H** Route the right handlebar switch lead, front brake hose (IN, OUT), front wheel sensor lead and throttle cables through the cover 8.
- I** Route the right handlebar switch lead, front brake hose (IN) and throttle cables (2 cables) through the wire guide of the upper bracket.
- J** Fasten the right handlebar switch lead to the handlebar with a band.
- K** Fasten the main switch lead and immobilizer lead with a clamp so that it faces the front side of the vehicle.
- L** Fasten the horn lead to the front fork (left side) with a clamp as shown in the drawing. Cut the clamp tip leaving 3 ~ 8 mm (0.12 ~ 0.31 in).

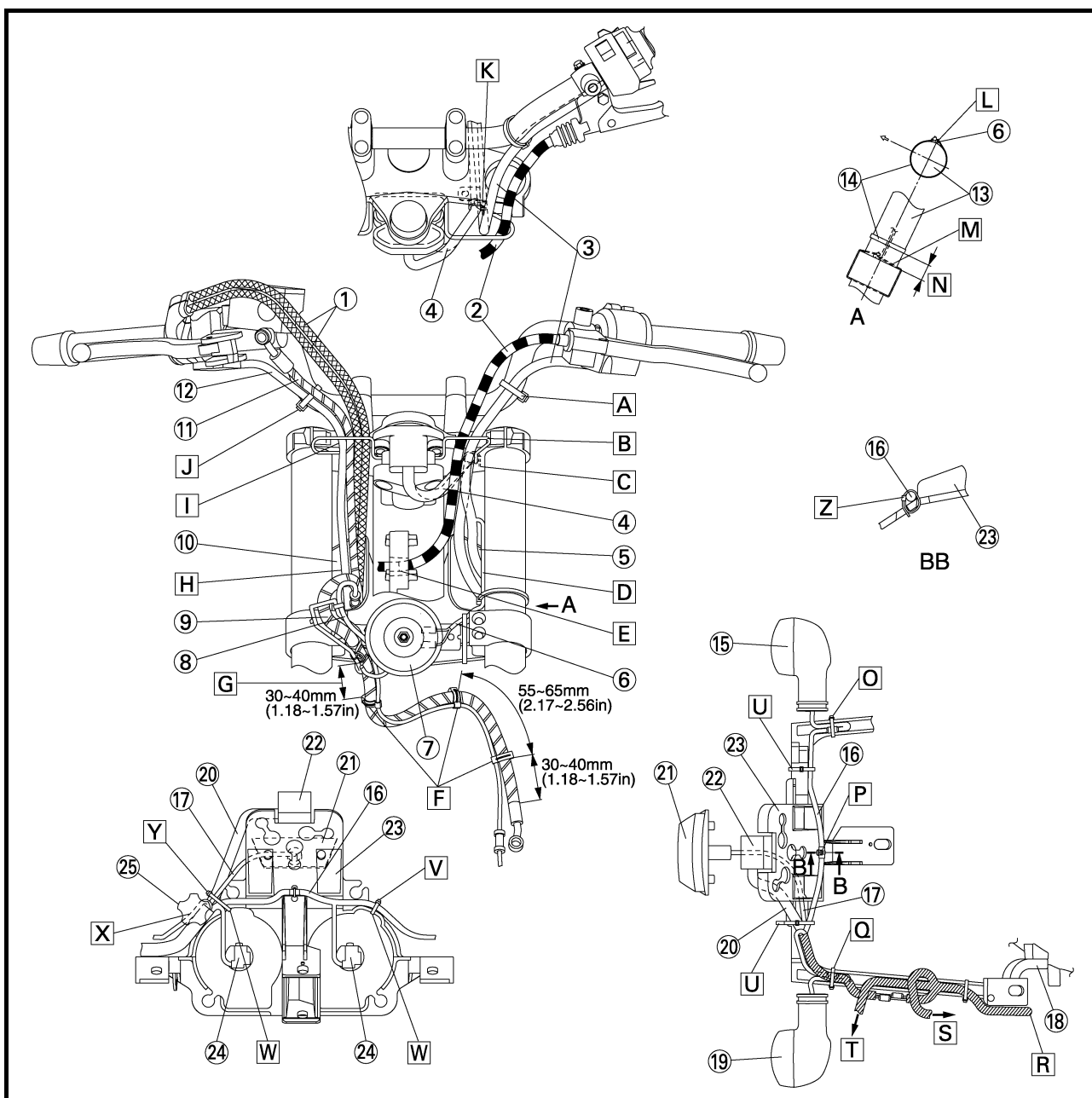



- M** Fasten the horn lead to the upper side of the under bracket as shown in the drawing. Cut the clamp tip leaving 3 ~ 8 mm (0.12 ~ 0.31 in).
- N** 10 mm (0.39 in)
- O** Fasten the turn signal light lead (right) together with the coupler to the stay 1.
- P** Clamp the white tape of headlight sub-wire harness to the stay 1. (For detail of the clamp, refer to section BB.)
- Q** Fasten the wire harness and turn signal light lead (left) together with the coupler to the stay 1. And locate the turn signal light lead, under the wire harness.
- R** Route the wire harness through the outside of the bolt.
- S** To the headlight relay.
- T** To the ECU.
- U** After the clamping, direct the band point to the front.
- V** Clamp the headlight sub-wire harness to the stay 1 with a band.
- W** Clamp the headlight sub-wire harness to the dent in the stay 1.
- X** Route the all leads through inside of the headlight adjusting knob. Because of the protruding of the wire harness, it does not have to become the disturbance of operation of the headlight adjusting knob.
- Y** Clamp the meter lead, indicator light lead, headlight sub-wire harness to the stay 1 with a band.

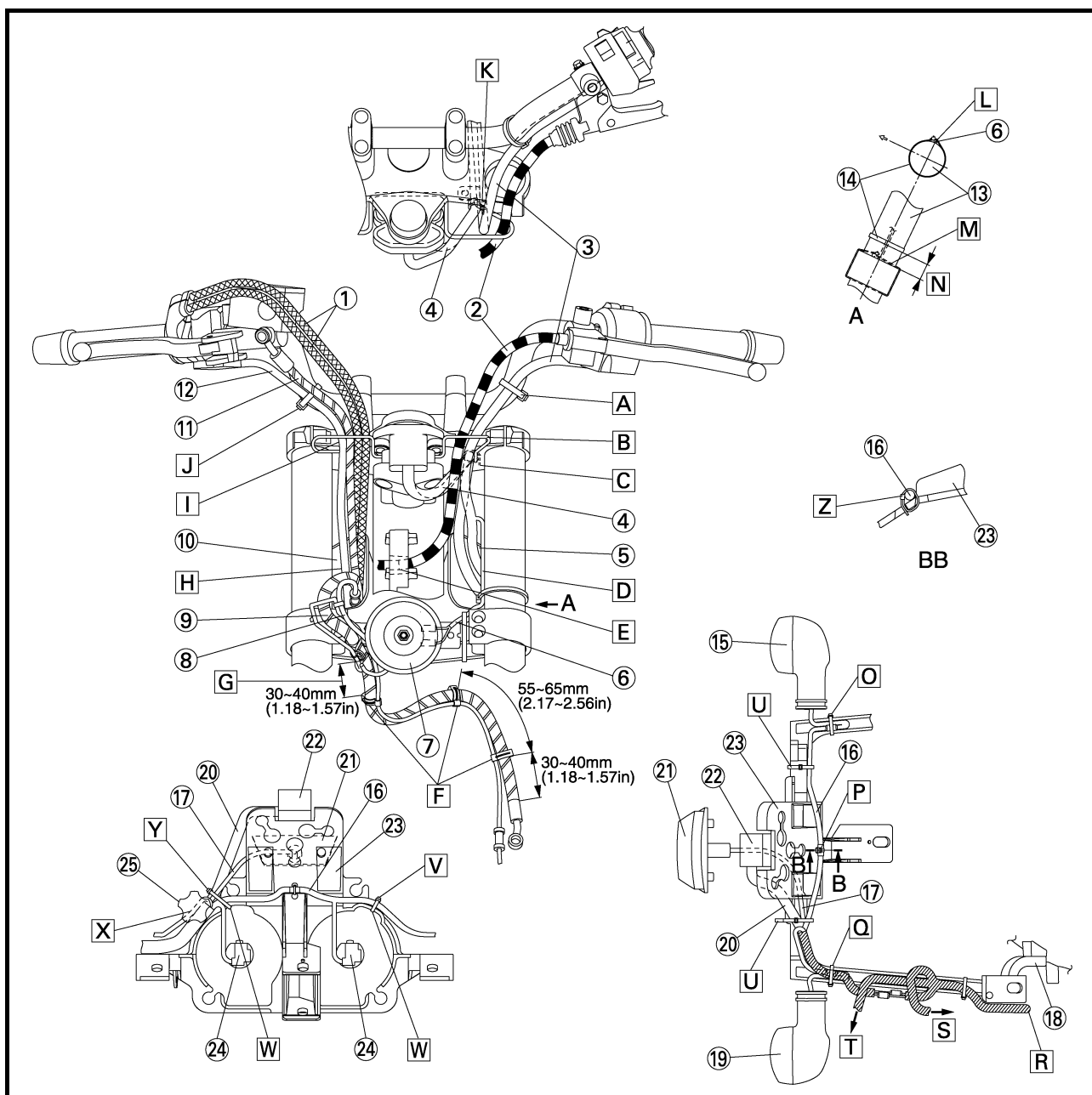



- ☒ Fasten the headlight sub-wire harness with the clamp that is passed through the center hole of stay 1.

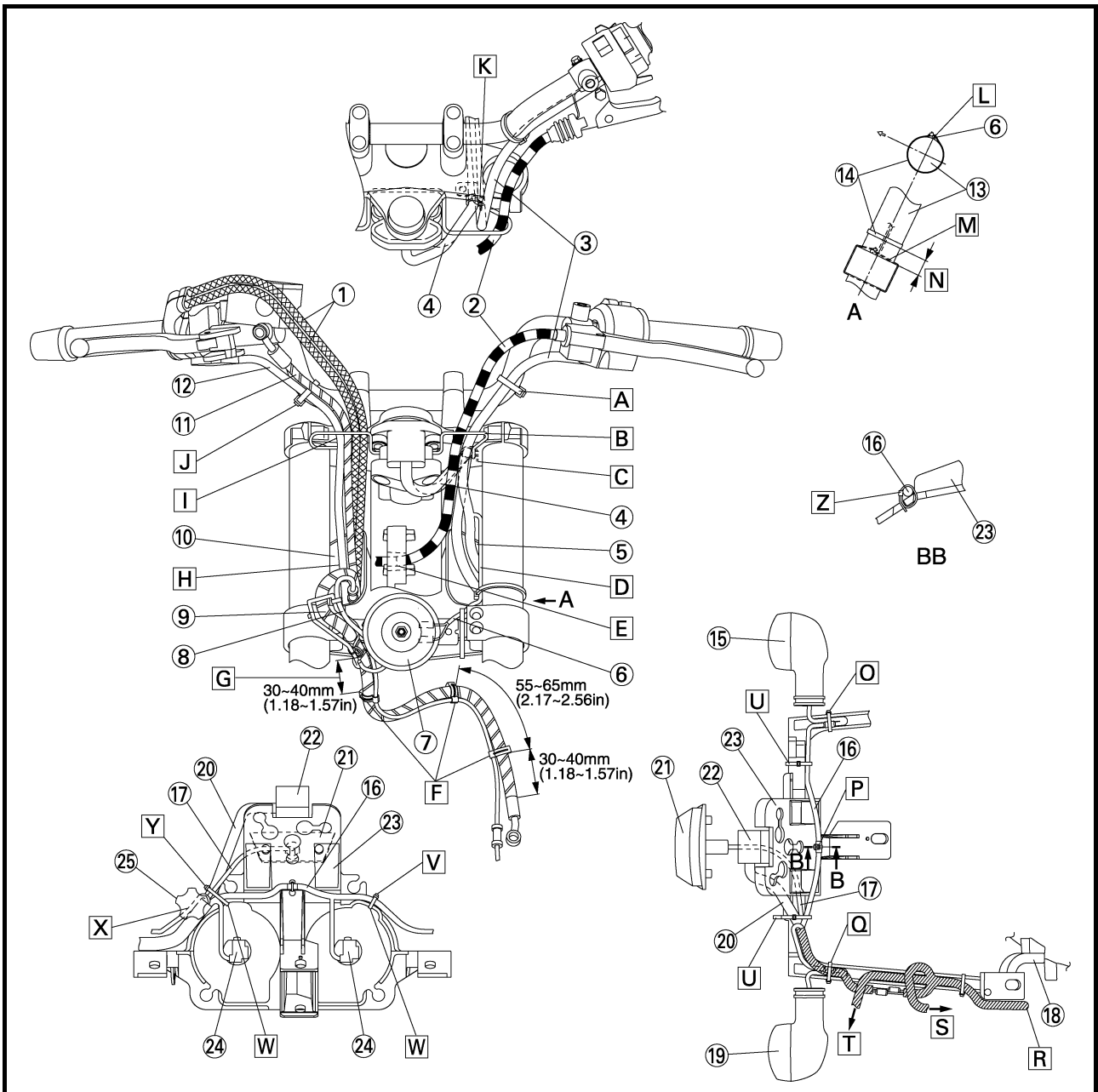

CABLE ROUTING

SPEC



- | | | |
|-------------------------------------|---------------------------------------|-------------------------------|
| ① Stay 3 | ⑬ Immobilizer coupler | ⑳ Turn signal light relay |
| ② Ignition coil assembly | ⑭ Joint coupler | ㉑ Headlight relay |
| ③ Neutral switch lead | ⑮ Tail/brake light lead | ㉒ Main relay |
| ④ O ₂ sensor lead | ⑯ Rear turn signal light | ㉓ Front wheel sensor |
| ⑤ Speed sensor lead | ⑰ Rear turn signal light lead | ㉔ ECU |
| ⑥ Sidestand switch lead | ⑱ Rectifier/regulator lead | ㉕ ECU lead |
| ⑦ Pickup coil lead | ⑲ Coolant reservoir tank | ㉖ Stay 1 |
| ⑧ Fuel tank drain hose | ㉑ Rear shock absorber | ㉗ 6 poles water proof coupler |
| ⑨ Air filter drain hose | ㉒ Swingarm | ㉘ Boss |
| ⑩ Coolant reservoir tank drain hose | ㉓ Sidestand switch | ㉙ Starter motor lead |
| ⑪ Battery negative lead | ㉔ O ₂ sensor | ㉚ Frame |
| ⑫ Seat lock cable | ㉕ Cylinder identification sensor lead | ㉛ Engine |
| | | ㉜ Oil pipe |

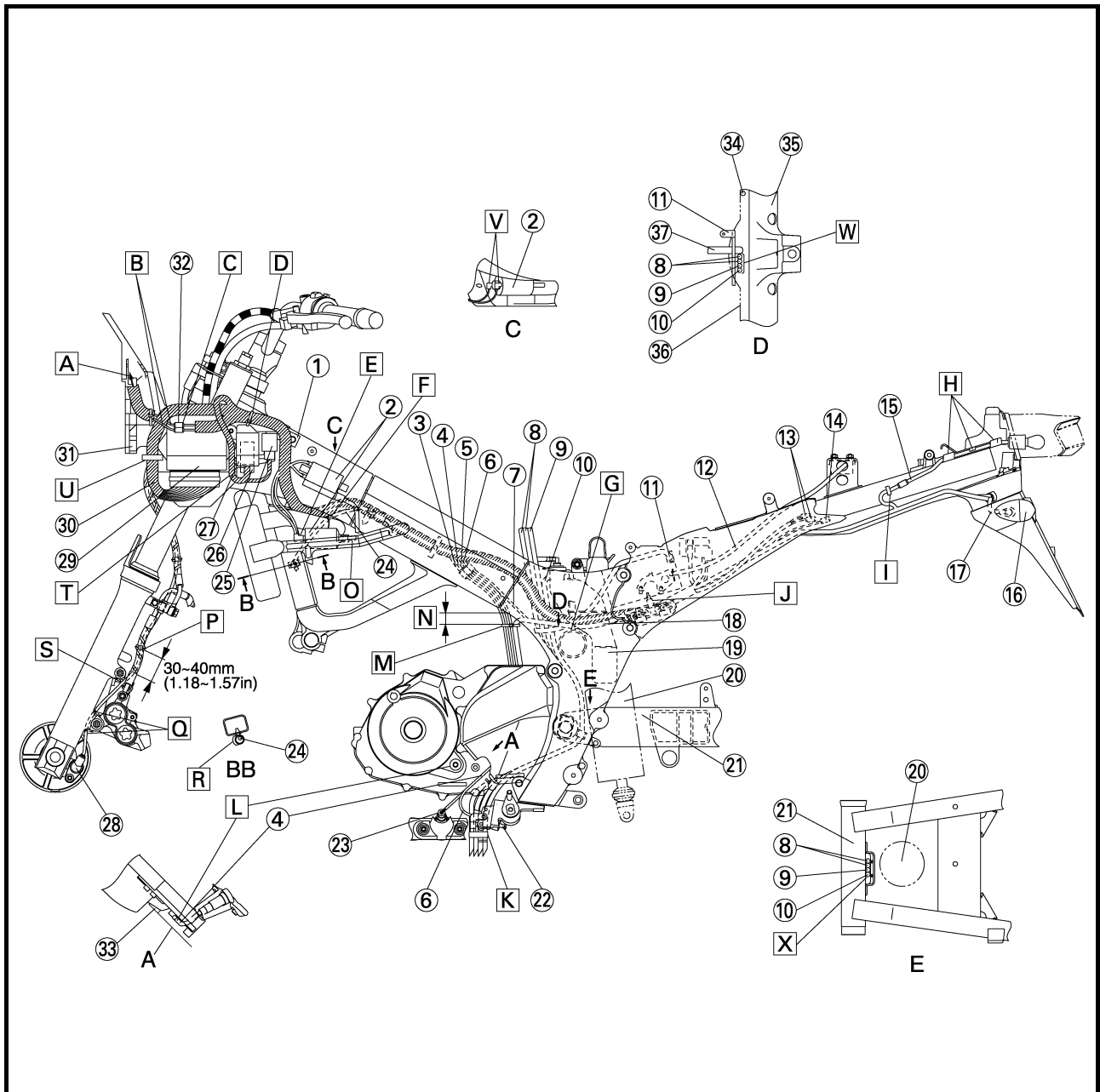



- A** To the headlight.
- B** Route the 6 poles water proof coupler through inside of the ECU lead, and the 12 poles coupler through outside of the ECU lead.
- C** Connect the headlight sub-wire harness coupler in front of ECU and make it not to route above the ECU lead.
- D** Fasten the wire harness to the stay 1 with a clamp. Clamp position shall be at the position shown in the drawing 1. The knot should be faced to the outside of the vehicle.
- E** Insert the terminal (black) of the ignition coil lead as shown in the drawing.
- F** Pass the cylinder identification sensor lead above the left radiator hose.
- G** Pass the rectifier/regulator lead above the frame cross tube.
- H** Route the tail/brake light lead through the guides (3 places) of the tail/brake light bracket.
- I** Fasten the tail/brake light lead at outside of the frame with a clamp. After connecting the tail/brake light lead coupler, insert the surplus wiring between frame, and positioning without routing above the frame.
- J** Fasten the rectifier/regulator lead with the clamp installed with the rear fender. The clamp tip should face the inner side of the vehicle.

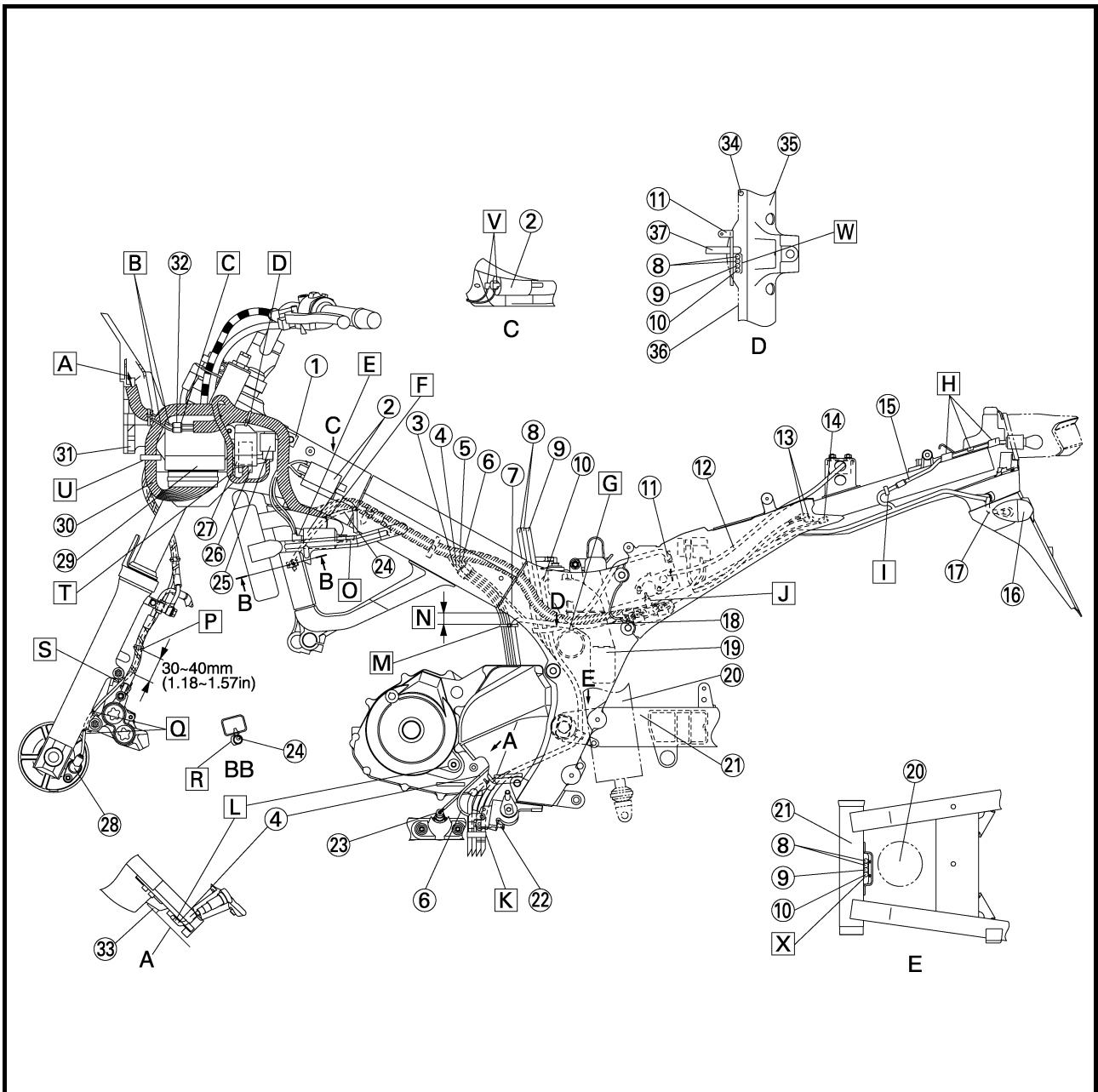

CABLE ROUTING

SPEC



- K** Route the fuel drain hoses (2 hoses), air filter drain hose, and coolant reservoir tank drain hose through the clamp. For the fuel drain hose, the white paint mark should be under the clamp. The position is regardless of ranks. Arrange the end of coolant reservoir tank drain hose, air filter case drain hose and fuel drain hose from the clamp.
- L** The O₂ sensor lead should not stick out from the boss seat face to the outside of the vehicle.
- M** Fasten the neutral switch lead, O₂ sensor lead, speed sensor lead, sidestand switch lead and rectifier/regulator lead with the clamp as shown in the drawing. Cut the clamp tip leaving 3 ~ 8 mm (0.12 ~ 0.31 in) and make it face to the outside of the vehicle.
- N** Less than 20 mm (0.79 in)
- O** Route the spark plug lead for the right cylinder below the water pipe and behind the hose for the air cut-off valve.
- P** Route the front wheel sensor lead inside the vehicle and secure it to the front brake hose with a clamp.
- Q** Pass the front wheel sensor lead through the cable holder tightened together with the front brake caliper.
- R** Fasten the cylinder identification sensor lead to the inner side of the frame with a clamp.
- S** Pass the front wheel sensor lead between the front brake caliper and front brake hose.

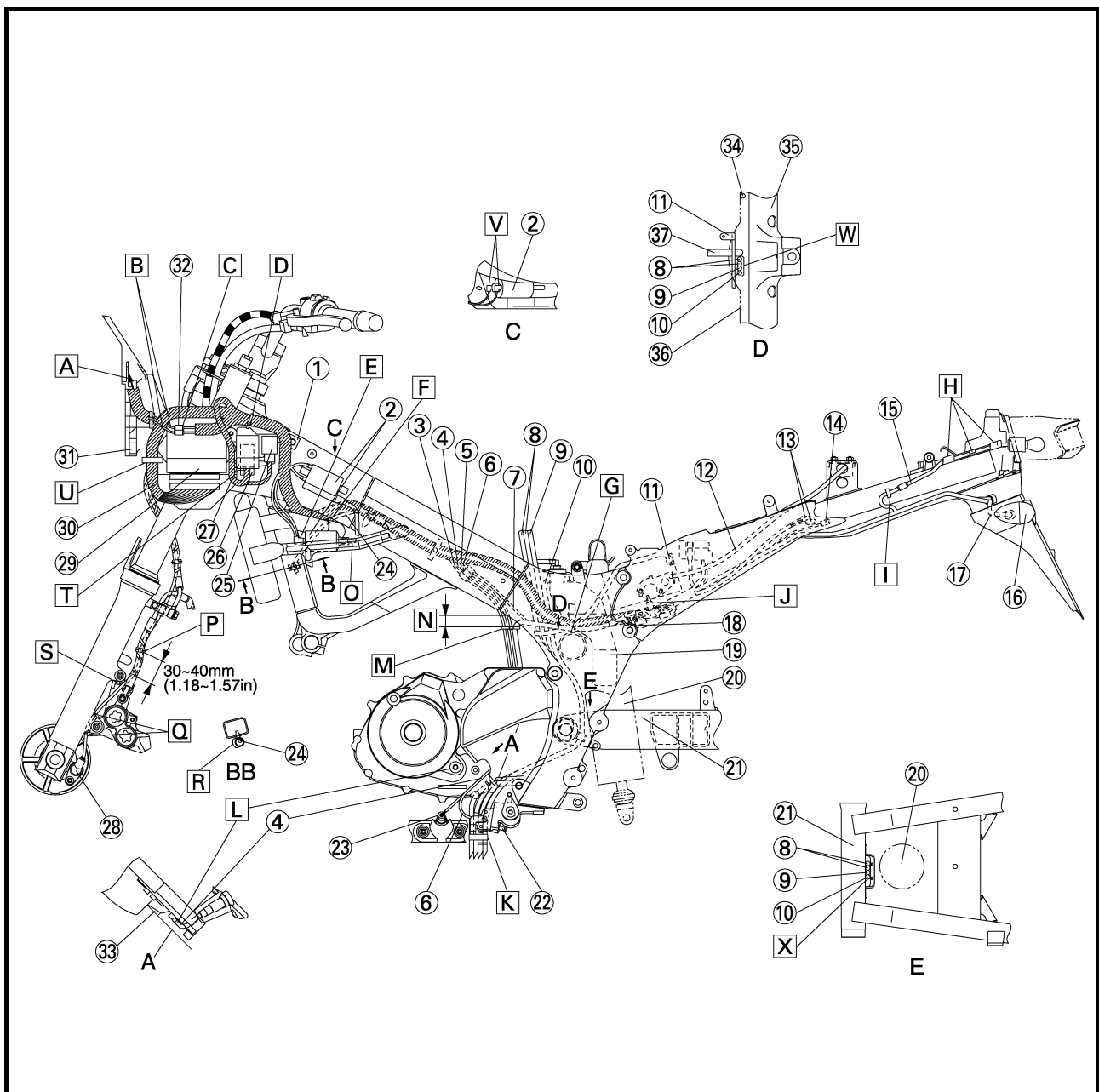



- T** Pass the harness for the relay between ECU and the main relay.
- U** Fasten the ECU lead with the clamp installed to the plate of front side hole. Align the positioning tape and the clamp. Install the clamp to the out side of plate.
- V** Insert the terminal (white) of the spark plug lead as shown in the drawing.
- W** Pass the fuel drain hose coolant reservoir tank drain hose and air filter drain hose behind the battery negative lead.
- X** Route the fuel drain hoses (2 hoses), air filter drain hose and coolant reservoir tank drain hose through the guide located behind the swingarm head pipe. Do not make hoses to cross in the area between D and E.

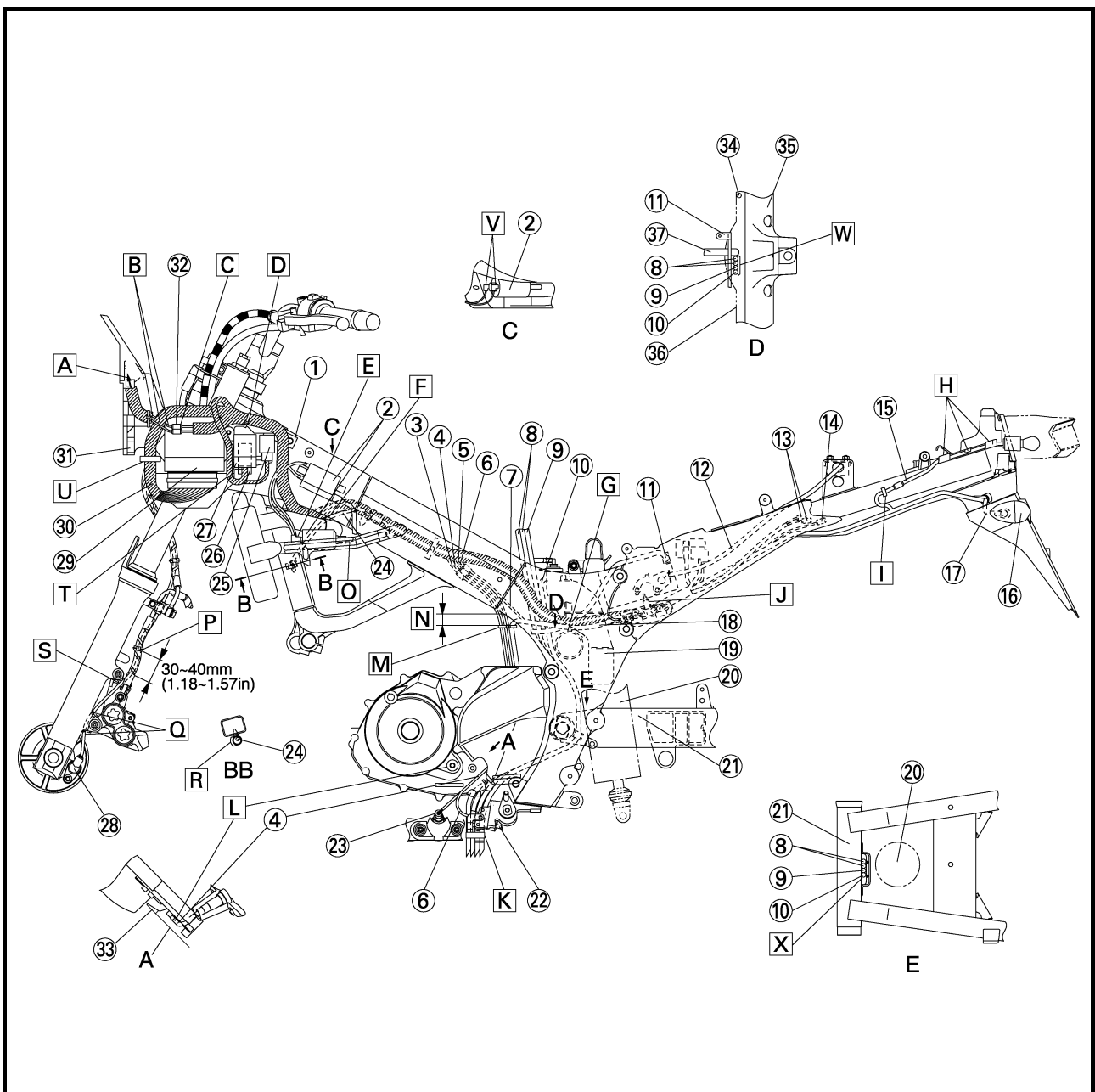

CABLE ROUTING



- ① Seat bracket
- ② Front wheel sensor lead
- ③ ECU (ABS) sub-wire harness
- ④ ECU (ABS)
- ⑤ Radiator fan motor relay
- ⑥ ABS check coupler
- ⑦ Brake hose holder
- ⑧ Stay 2
- ⑨ Radiator
- ⑩ Clutch cable
- ⑪ Thermo wax hose
- ⑫ Coolant reservoir tank hose
- ⑬ Rear brake hose
- ⑭ Starter motor lead
- ⑮ Hydraulic unit drain hose
- ⑯ Rear brake light switch lead
- ⑰ Rear brake light switch
- ⑱ Rear wheel sensor lead
- ⑲ Brake fluid reservoir hose
- ⑳ Clamp
- ㉑ Rear brake hose (OUT)
- ㉒ Rear brake hose (IN)
- ㉓ Fuel tank return hose
- ㉔ Fuel hose
- ㉕ Fuel tank drain hose
- ㉖ Clamp
- ㉗ Clamp
- ㉘ Brake hose holder
- ㉙ Rear wheel sensor lead
- ㉚ Clamp

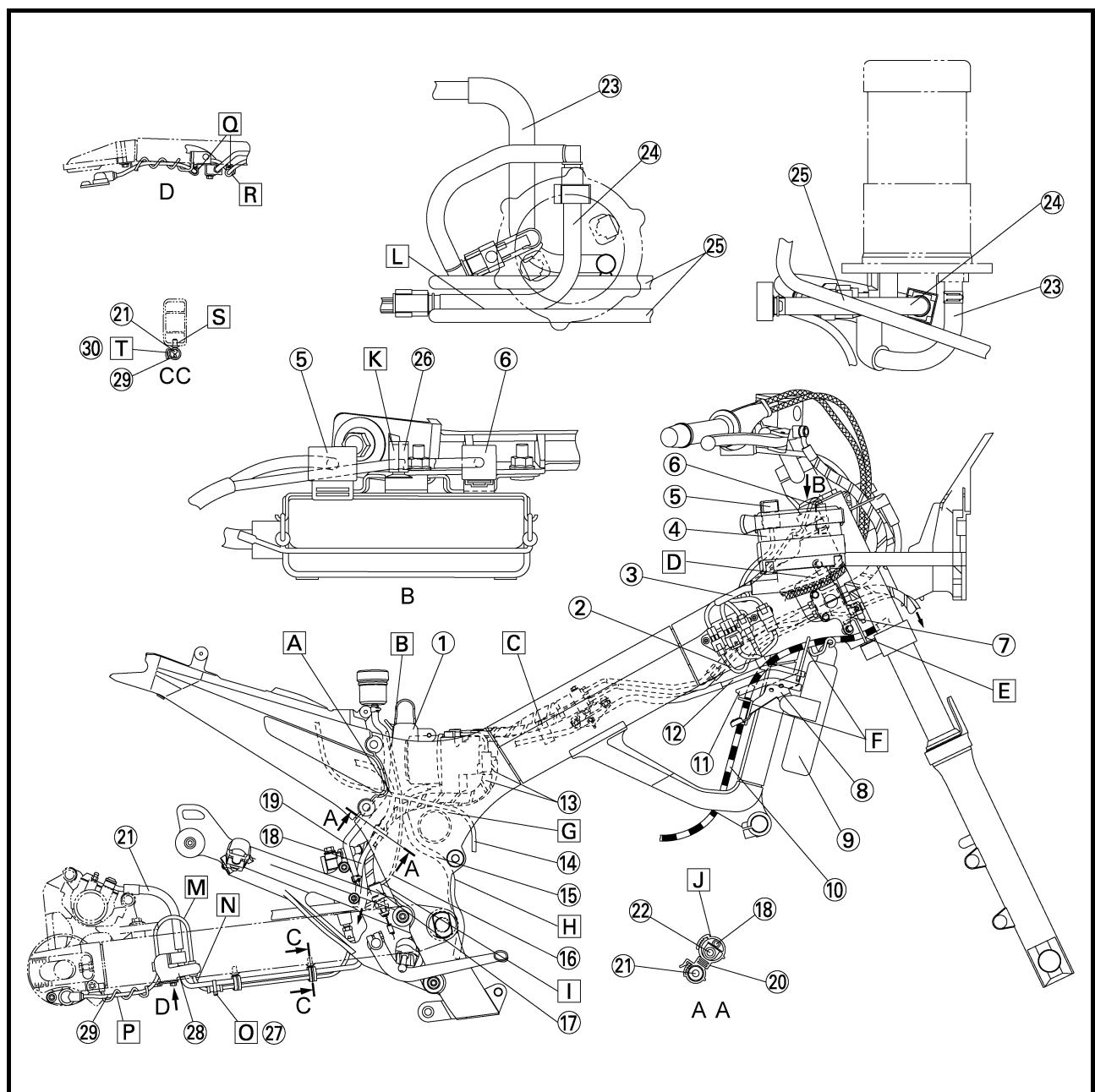

CABLE ROUTING

SPEC



- A** The right and left positions for the starter motor lead and rear wheel sensor lead can be accepted in random order.
- B** Pass the brake fluid reservoir hose and the rear-brake light switch lead through the gap between the rear fender and rear frame and route it behind the seat bracket.
- C** Clamp the coolant reservoir tank hose and brake hose.
Clamping position should be behind the protector and of the coolant reservoir tank hose.
- D** Route the throttle cables and right handlebar switch lead inside of the brake hose holder.
- E** Route the clutch cable through the guide of brake hose holder.
- F** Route the clutch cable through the guide of stay 2.
- G** Route the rear brake hose and starter motor lead over the frame cross tube.
- H** Route the hydraulic unit drain hose behind the cross tube, front of the oil hose and also front of the pivot shaft.
- I** Direct the rear brake light switch lead to the front.
- J** Clamp the grommet parts of the rear brake hose and rear wheel sensor lead.
- K** Clamp the ABS check coupler lead. Either upward or downward direction of pawl is acceptable.
- L** Pass the fuel hose between the fuel tank drain hoses
- M** Route by the outside of the brake hose.
- N** Ensure that the leads are not folded.
- O** Point the tip of the clamp downward and cut the surplus part leaving 0 ~ 5 mm (0 ~ 0.20 in).

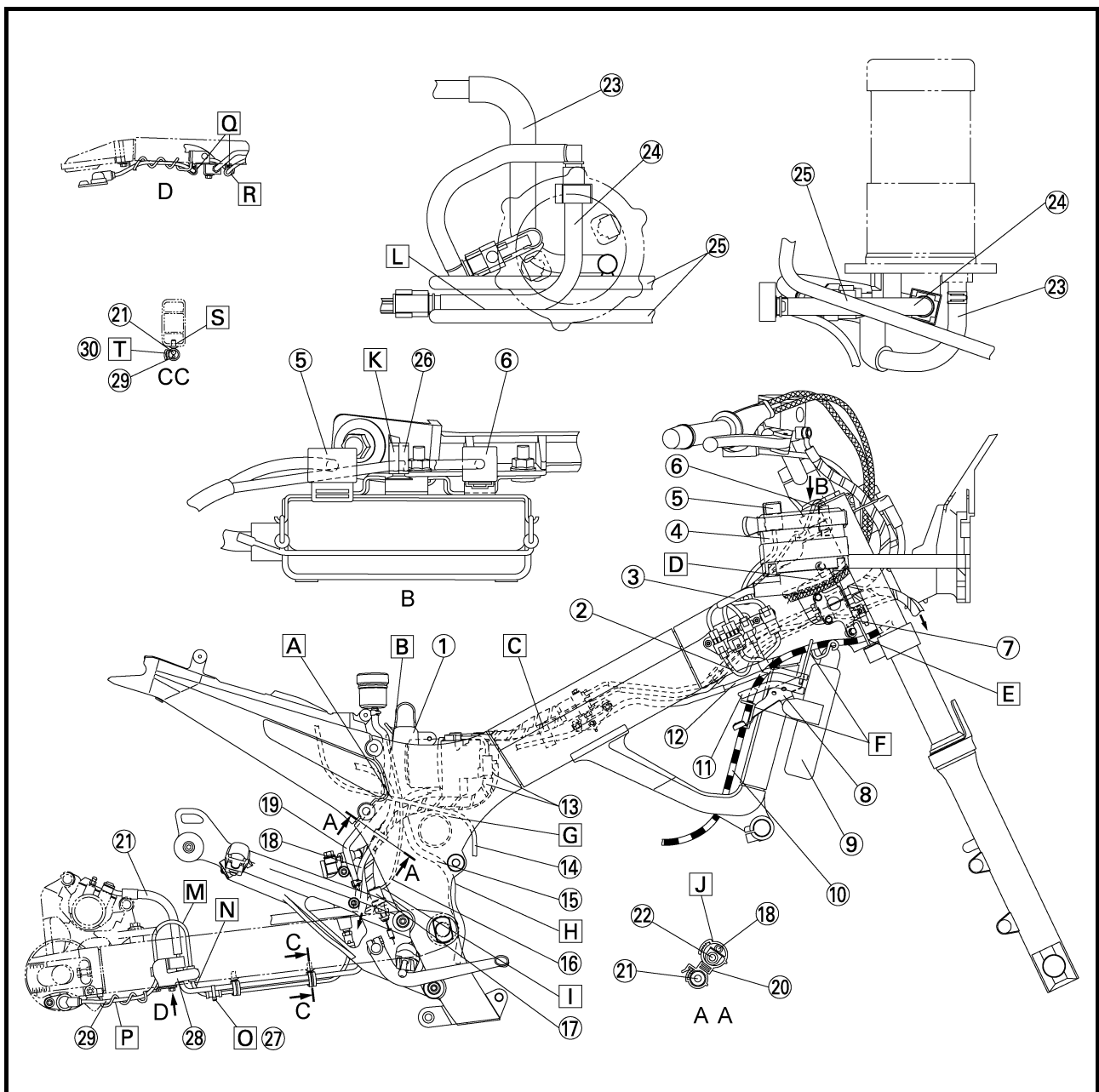



- P** Route inside the brake hose holder.
- Q** Attach the clamp so that its opening section faces in the direction indicated in the drawing.
- R** Clamp the grommet which is attached to the sensor lead.
- S** Make sure to insert it to the deepest point.
- T** Make sure to catch more than 3 notches. Install the pawl so that it points to the outside of the vehicle.

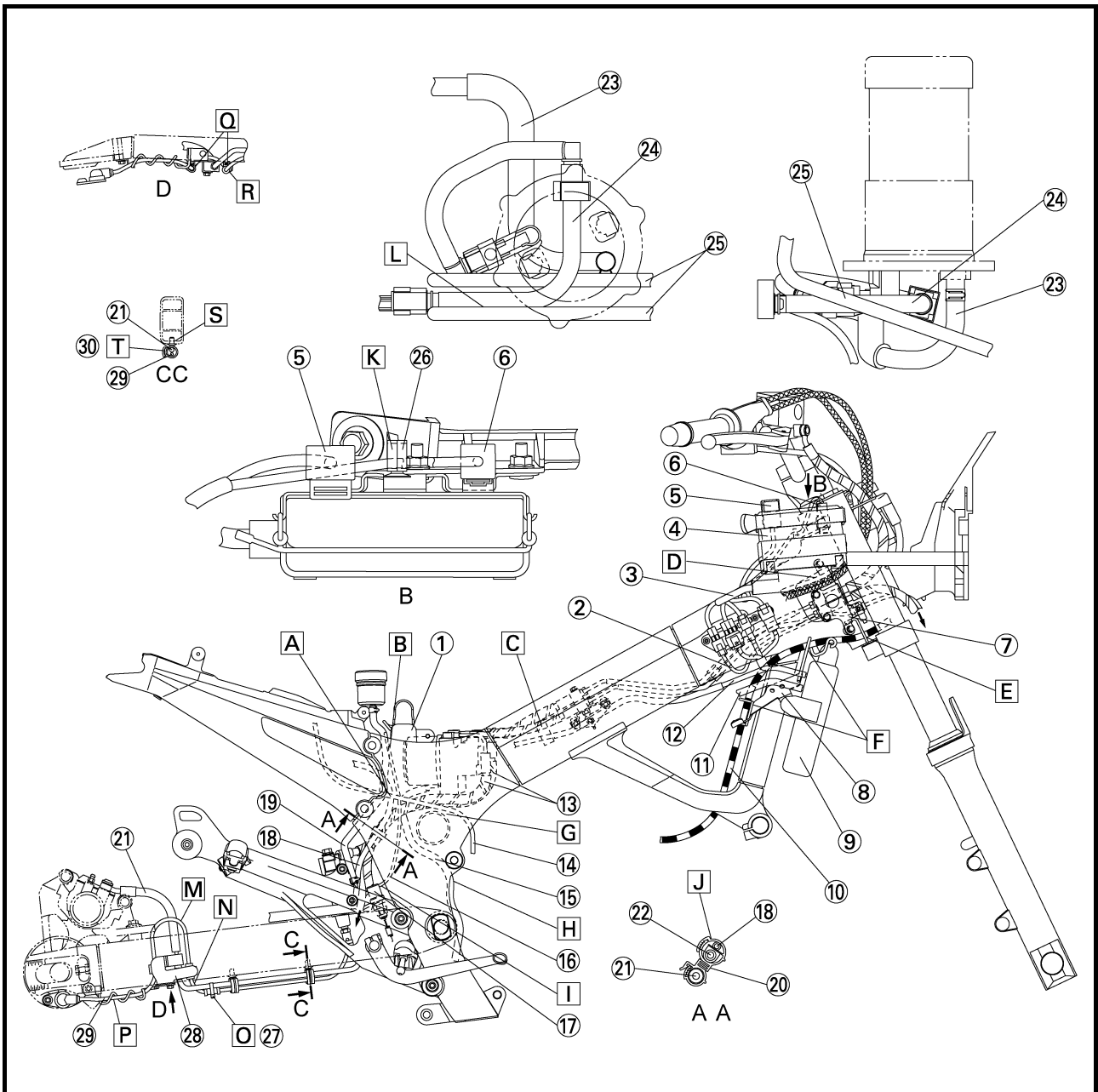

CABLE ROUTING

SPEC



- | | |
|--------------------------------------|---------------------------------------|
| ① Throttle cables | ⑮ Battery |
| ② Handlebar switch lead (right) | ⑯ Rectifier/regulator |
| ③ Front brake hose | ⑰ Rear wheel sensor lead |
| ④ Stay | ⑱ Starter motor lead |
| ⑤ Front wheel sensor lead | ⑲ Battery band |
| ⑥ Thermo wax hose | ⑳ Battery positive lead |
| ⑦ Intake vacuum hose | ㉑ Lean angle cut-off switch |
| ⑧ Sub-wire harness (air filter case) | ㉒ Atmospheric pressure sensor |
| ⑨ Oil level switch lead | ㉓ Fuse (main) |
| ⑩ Hydraulic unit lead | ㉔ Starter relay |
| ⑪ Coolant reservoir tank hose | ㉕ Rear turn signal light lead (right) |
| ⑫ Hydraulic unit assembly | ㉖ Rear turn signal light (right) |
| ⑬ Fail-safe relay | ㉗ Tail/brake light lead |
| ⑭ Rear brake light switch lead | ㉘ Tail/brake light |
| | ㉙ Rear turn signal light lead (left) |

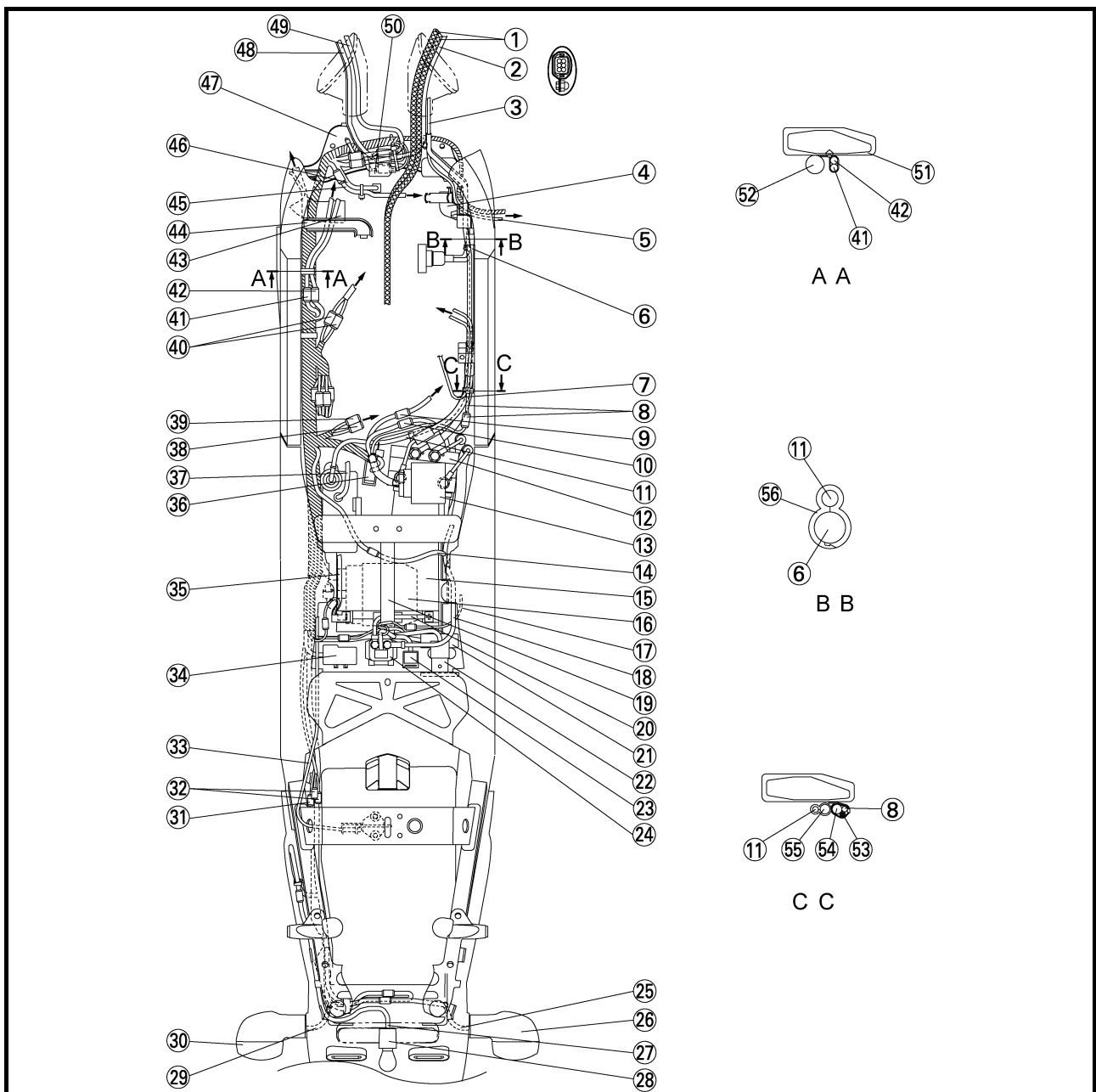

CABLE ROUTING

SPEC



- ③① Joint coupler
- ③② Immobilizer coupler
- ③③ Seat lock cable
- ③④ Fuse box
- ③⑤ Battery negative lead
- ③⑥ Hydraulic unit motor coupler
- ③⑦ Coolant reservoir tank drain hose
- ③⑧ Fuel pump lead 2
- ③⑨ Fuel pump lead 1
- ④① Sub-wire harness (throttle body)
- ④② Radiator fan motor lead
- ④③ Cylinder identification sensor lead
- ④④ Hose 1
- ④⑤ Air induction system lead
- ④⑥ Coolant temperature sensor lead
- ④⑦ Cover 2
- ④⑧ Main switch lead and immobilizer lead
- ④⑨ Left handlebar switch lead
- ⑤① Frame
- ⑤② Wire harness
- ⑤③ Intake vacuum hose (Joint section)
- ⑤④ Front brake hose (IN)
- ⑤⑤ Front brake hose (OUT)
- ⑤⑥ Clamp
- ① Rear turn signal light (left)
- ② Bracket 1
- ③ Cover 1
- ④ Fuel tank
- ⑤ Fuel tank
- ⑥ Fuel tank
- ⑦ Fuel tank
- ⑧ Fuel tank
- ⑨ Fuel tank
- ⑩ Fuel tank
- ⑪ Fuel tank
- ⑫ Fuel tank
- ⑬ Fuel tank
- ⑭ Fuel tank
- ⑮ Fuel tank
- ⑯ Fuel tank
- ⑰ Fuel tank
- ⑱ Fuel tank
- ⑲ Fuel tank
- ⑳ Fuel tank
- ㉑ Fuel tank
- ㉒ Fuel tank
- ㉓ Fuel tank
- ㉔ Fuel tank
- ㉕ Fuel tank
- ㉖ Fuel tank
- ㉗ Fuel tank
- ㉘ Fuel tank
- ㉙ Fuel tank
- ㉚ Fuel tank
- ㉛ Fuel tank
- ㉜ Fuel tank
- ㉝ Fuel tank
- ㉞ Fuel tank
- ㉟ Fuel tank
- ㊱ Fuel tank
- ㊲ Fuel tank
- ㊳ Fuel tank
- ㊴ Fuel tank
- ㊵ Fuel tank
- ㊶ Fuel tank
- ㊷ Fuel tank
- ㊸ Fuel tank
- ㊹ Fuel tank
- ㊺ Fuel tank
- ㊻ Fuel tank
- ㊼ Fuel tank
- ㊽ Fuel tank
- ㊾ Fuel tank
- ㊿ Fuel tank

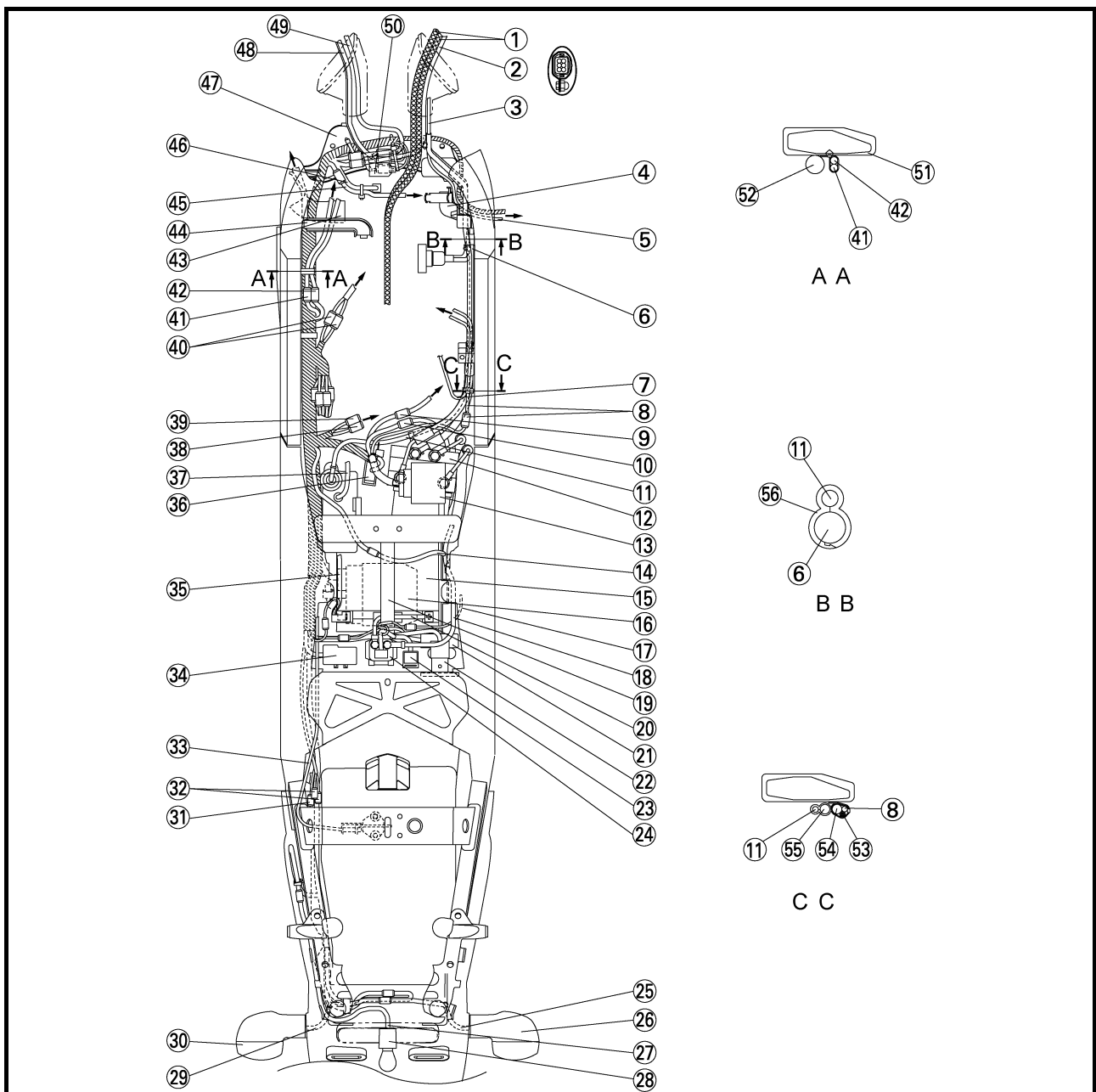

CABLE ROUTING

SPEC



- A** Put the cover on the coupler for the immobilizer lead and wire harness.
- B** Install the projection part of the coupler pointing to the connector housing 2.
- C** Align the projection part of the connector housing 2 with the hole of the locking bracket.
- D** Attach the boot over the immobilizer coupler.
- E** To the air induction system.
- F** To the ECU (ABS).
- G** To the air filter case.
- H** Route the sub-wire harness (air filter case) and intake vacuum hose over or side by the brake hose.
- I** To the oil tank.
- J** Route the starter motor lead and rear wheel sensor lead under the rear frame attaching boss section.
- K** Route the starter motor lead and rear wheel sensor lead by the right of the battery. The upper and lower positions of the leads can be accepted in random order.
- L** Route the battery positive lead under the battery band. (secure with a band)
- M** Pass the rear turn signal light lead (right) through the right hole of the fender.
- N** Pass the rear turn signal light leads (right and left) through the clamp installed to the rear fender. Adjust the length of the rear turn signal light lead (left) by folding and then bundle it.
- O** Pass the rear turn signal light lead (left) through the left hole of the fender.
- P** Pass the rear turn signal light leads (right and left) between the ribs of the rear fender.

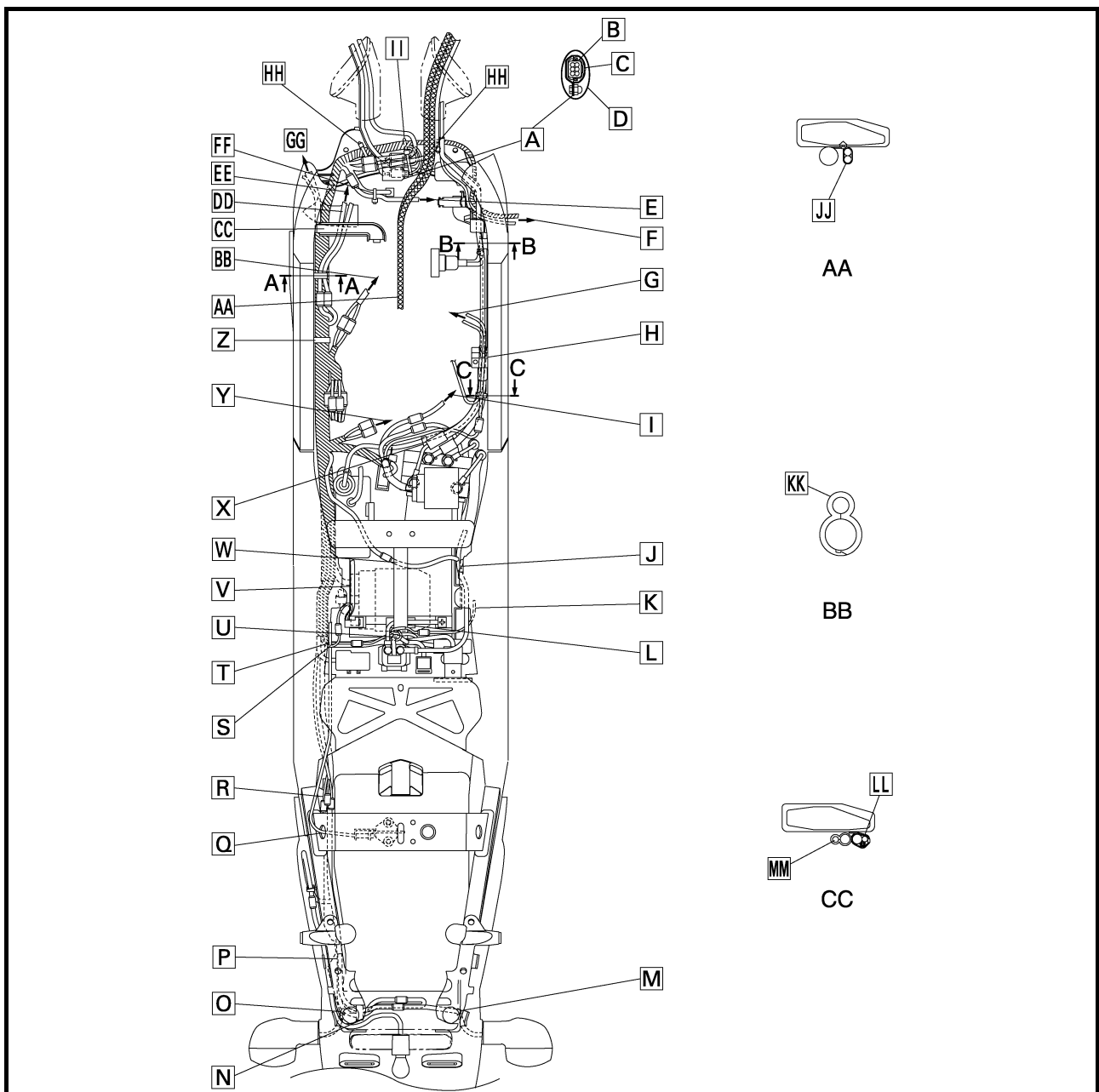

CABLE ROUTING

SPEC



- Q** Pass the seat locking cable through the hole section of the seat bracket of the rear frame. Either direction of the seat locking cable can be accepted.
- R** Set the immobilizer coupler and joint coupler between the ribs of the rear fender.
- S** Route the battery negative lead (black lead) above the seat locking cable.
- T** Route the battery positive lead (red lead) below the seat locking cable.
- U** Route the battery positive lead together with the rear wheel sensor lead and starter motor lead as shown in the illustration.
- V** Route the battery negative lead above the battery.
- W** Route the rear brake light switch lead below the battery band. (secure with a band.)
- X** Clamp the coolant reservoir tank hose to the hydraulic unit bracket.
- Y** To the fuel pump.
- Z** Fasten the wire harness to the inner side of the frame with the harness wrapping clamp.
- AA** Arrange to route the throttle cable so that its upper side is the return cable and lower side for the pulling cable.
- BB** To the throttle body.
- CC** Route the wire harness, cylinder identification sensor lead and radiator fan motor lead under the bracket 1.
- DD** Route the cylinder identification sensor lead and radiator fan motor lead above the radiator hose.
- EE** To the radiator.

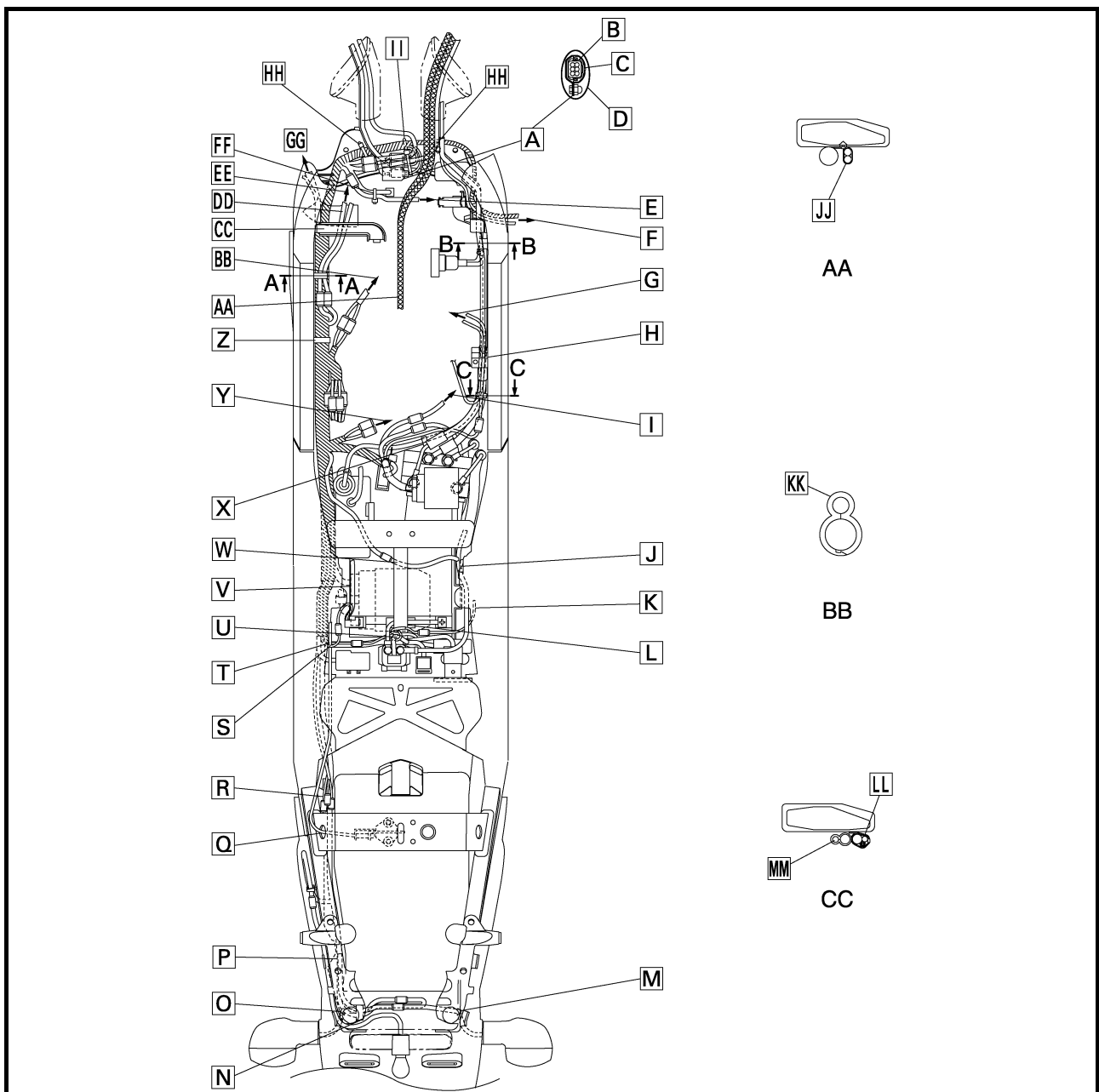



- FF** Bundle the coolant temperature sensor lead and air induction system lead with the clamp. Cut the clamp tip leaving 3 ~ 8 mm (0.12 ~ 0.31 in).
- GG** To the headlight.
- HH** Secure the wire harness to the holes at the internal left side and right side of the cover 2 with the harness wrapping clamp.
- II** Bundle the main switch lead, immobilizer lead, left handlebar switch lead and right handlebar switch lead with the clamp. Point the tip of the clamp to the front side and set it between cover and wire harness. Place the clamp at the right side of the vehicle from the coupler as shown in the illustration.
- JJ** Fasten the cylinder identification sensor lead and radiator fan motor lead to the frame with the clamp as shown in the illustration. Point the tip of the clamp to the downside.
- KK** Clamp it pointing the coolant reservoir tank hose to the outside and the throttle body hose to the inside. Position the clamp opening at the inside.
- LL** After binding a clamp, make sure to insert the excessive part to the gap with the frame.
- MM** Clamp the coolant reservoir tank hose and brake hose.

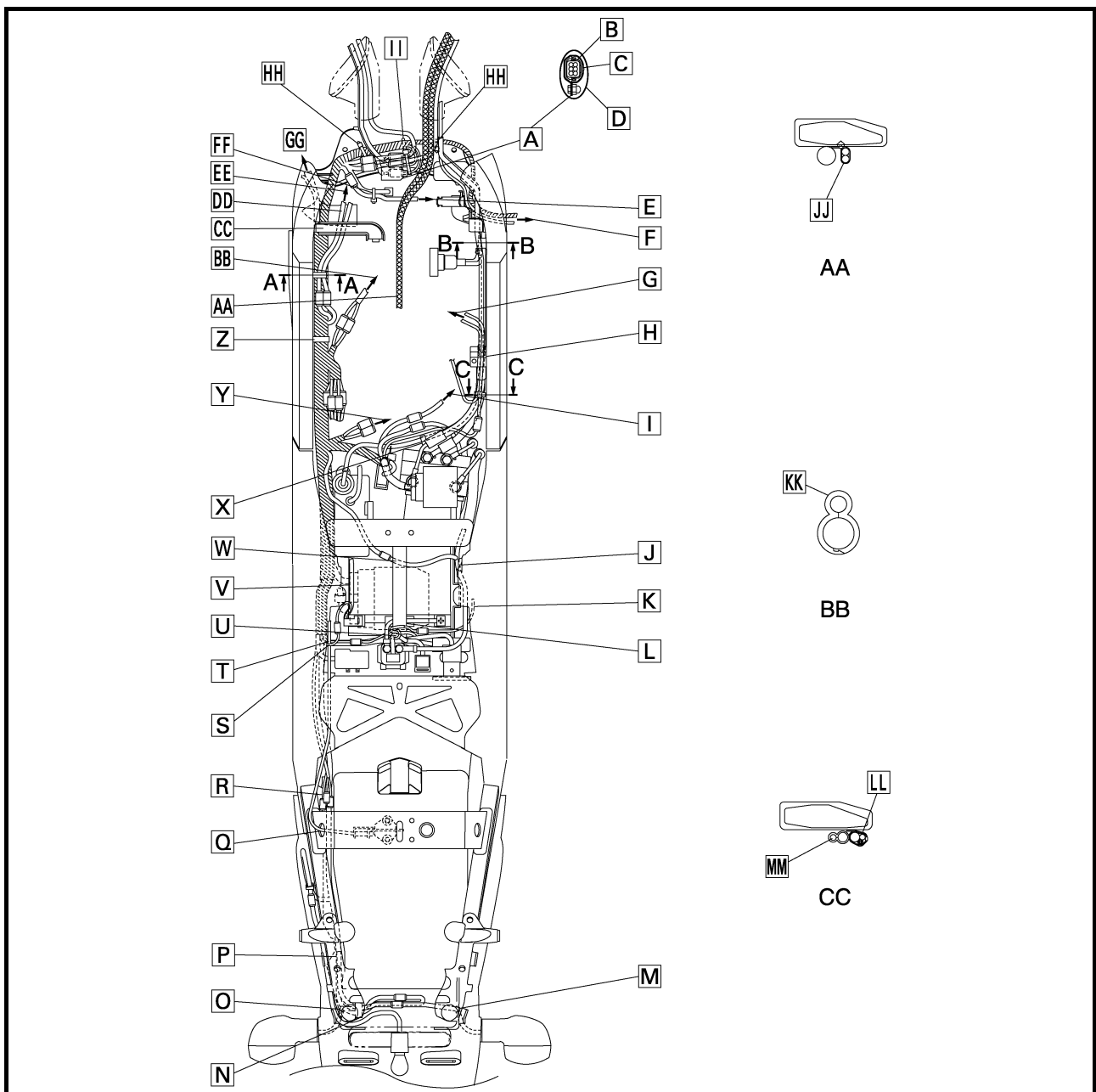

CABLE ROUTING

SPEC



- ① Intake vacuum hose joint
- ② Clip
- ③ Intake vacuum hose
- ④ Clamp (fuel pump side)
- ⑤ Clamp (injector side)
- ⑥ Air filter case
- ⑦ Air filter drain hose
- ⑧ Fuel pump
- ⑨ Fuel hose
- ⑩ Fuel tank return hose
- ⑪ Hose
- ⑫ Filter
- ⑬ Stay
- ⑭ Throttle body
- ⑮ Hose clamp (carburetor joint lowerside)
- ⑯ Carburetor joint

- ⑰ Hose clamp (carburetor joint upper side)
- A Connect the intake vacuum hose joint of the air filter system assembly side and the pipe of the throttle body side.
- B Make sure to match the white paint mark to the position right overhead.
- C Insert the hose until its end contacts the component. Point the pawl of the clip downward.
- D Install the clip so that its pawl is oriented within the rangeshown in the drawing.
- E To assemble to the throttle body assembly, it is allowed to apply the silicon liquid.

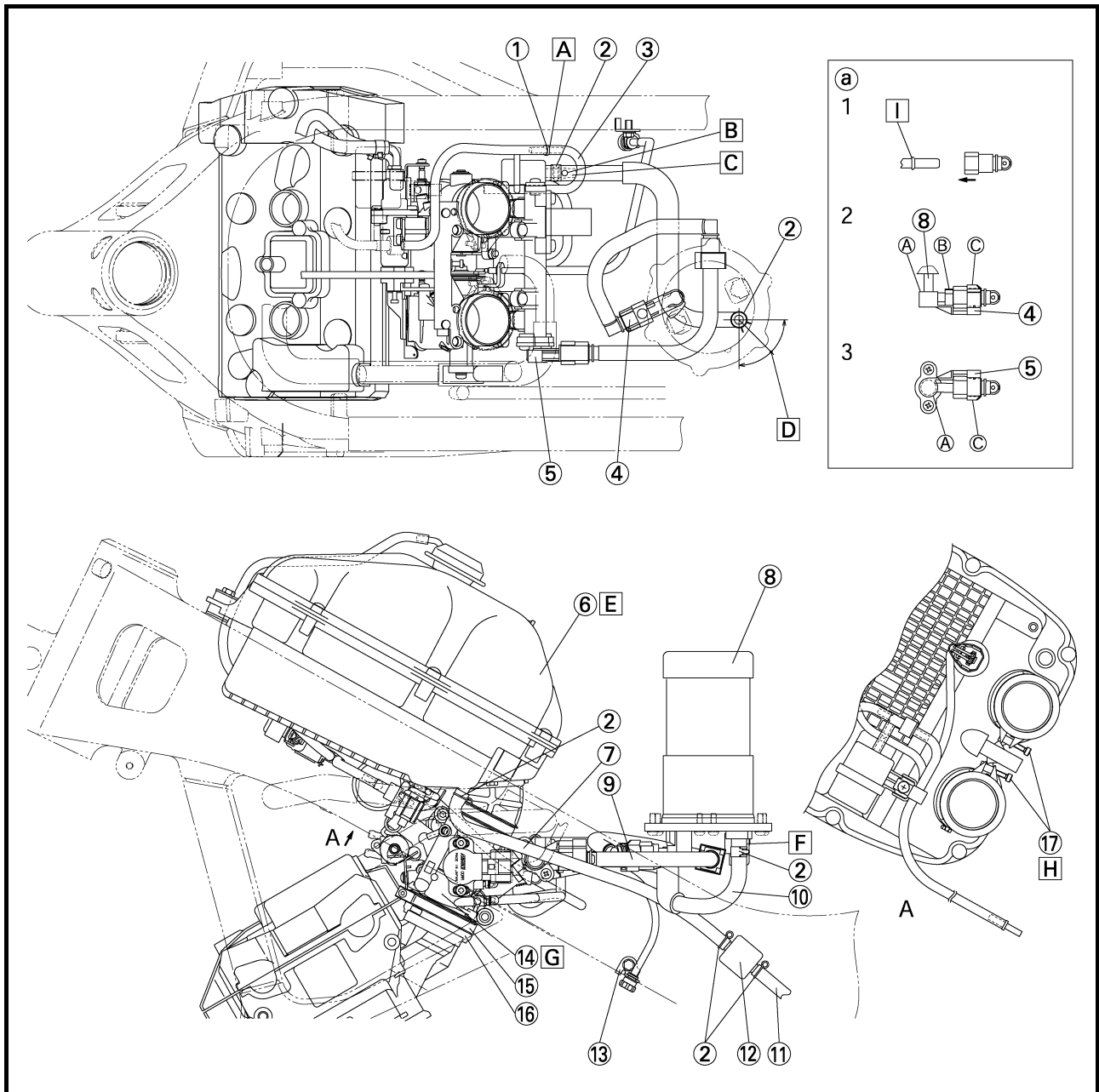

CABLE ROUTING

SPEC



- F** Insert the fuel tank return hose until its end contacts the component.
 - G** To assemble to the carburetor joint 1, it is allowed to apply the engine oil.
 - H** Attach the hose clamp in this direction.
 - I** This part works as a stopper against drop-off.
- a** Fuel piping connector attachment directions.
1. Insert the connector until the click sound is heard and check that the connector does not come off. Care should be taken so that the foreign matter is not caught. (It is prohibited to wear cotton work gloves during the operation.) Always use hands to connect/disconnect the connector without using tools.
 2. After the procedure item 1 as above is finished, insert the clamp of the fuel pump side from the lower side of the engine and check that the **A**, **B** and **C** parts are completely equipped.
 3. After the procedure item 1 as above is finished, lay over the **A** part of the injector side clamp from the engine left side and insert the **C** part from the engine upper side while turning. Check that the **A** and **C** parts are completely equipped.

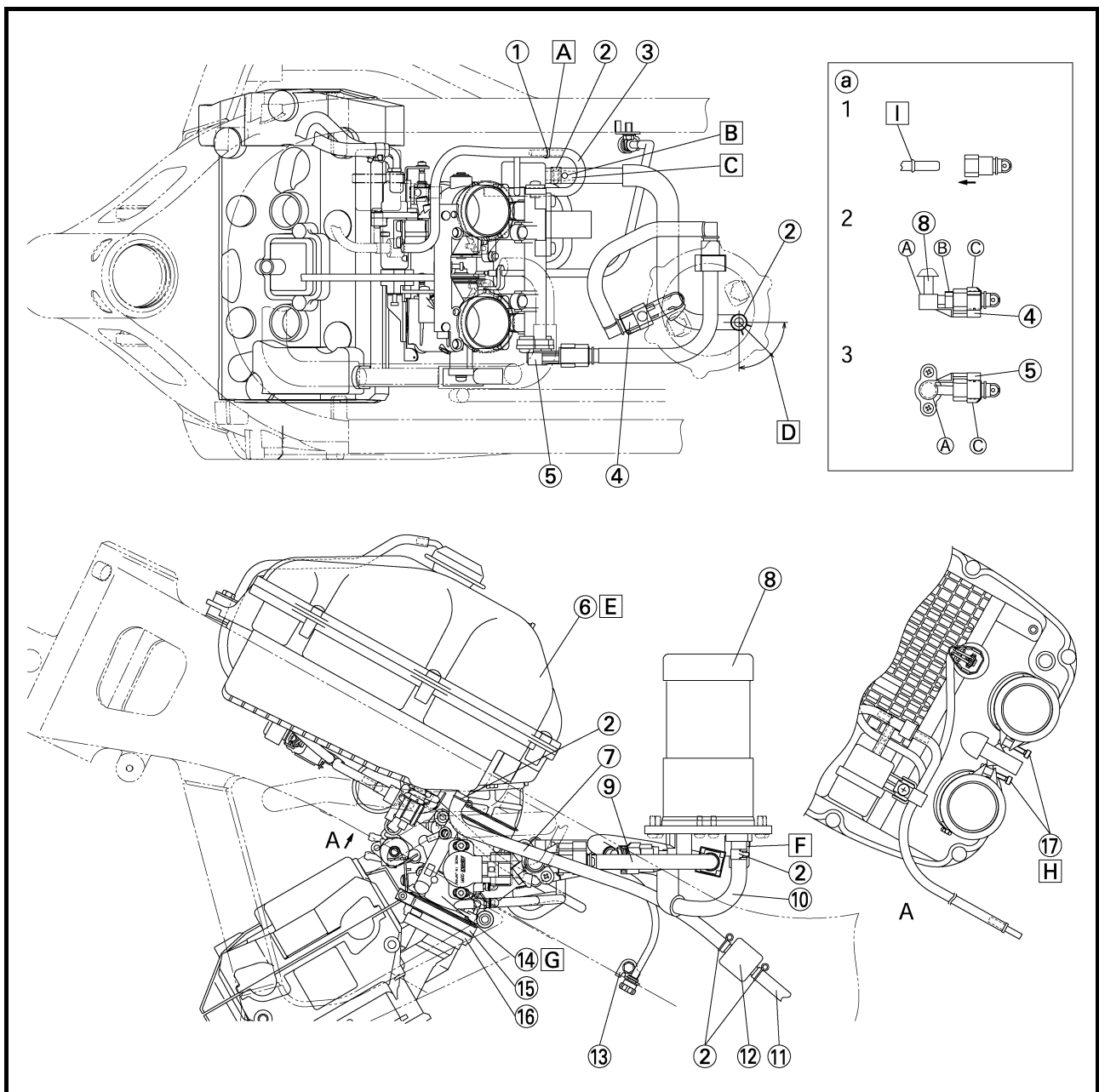



- ① Rear brake hose (OUT)
- ② Rear brake hose (IN)
- ③ Bracket 2
- ④ Frame
- ⑤ Bracket 1
- ⑥ Coolant reservoir tank
- ⑦ Wire harness assembly
- ⑧ Relay stay
- ⑨ Protector
- ⑩ Oil level sensor coupler
- ⑪ Hydraulic unit coupler
- ⑫ Front brake hose assembly (IN)
- ⑬ Front brake hose assembly (OUT)

- ⑭ Clamp
- ⑮ Drain plug
- ⑯ Hydraulic unit drain hose
- ⑰ Hydraulic unit motor coupler
- ⑱ Hydraulic unit assembly
- ⑲ Clamp (to the coolant reservoir tank hose)
- ⑳ Union bolt
- ㉑ Fail-safe relay
- ㉒ Brake hose holder
- ㉓ Fuel tank mold

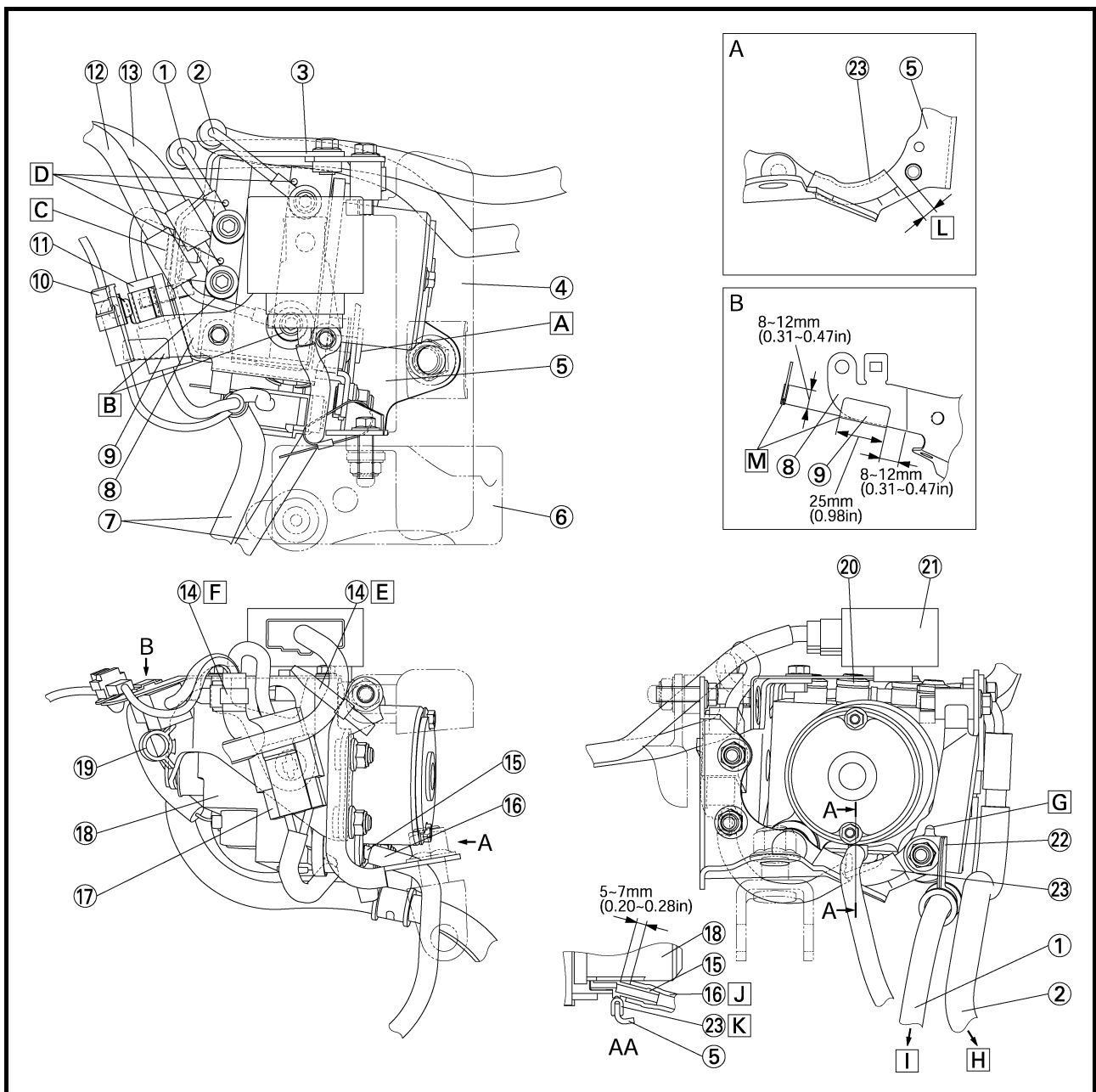

CABLE ROUTING

SPEC



- A** Insert the pin of the bracket 1 to the hydraulic unit assembly.
- B** Press front brake hose (IN) to the front brake hose assembly (out) and tighten.
- C** Insert the pin of the bracket 2 to the hydraulic unit assembly.
- D** Press brake hose to the detent pin of the hydraulic unit assembly and tighten.
- E** Clamp the wire harness assembly (for the fail-safe relay) to the bracket 1.
- F** Clamp the wire harness assembly. Clamp position should be at the white taping section of the wire harness assembly.
- G** Insert brake hose holder projection to the hole.
- H** To the rear brake master cylinder.
- I** To the rear brake caliper.
- J** Insert hydraulic unit drain hose to the deepest point.
- K** Fit the fuel tank mold in the bracket 1.
- L** Keep approximately 7 ~ 10 mm (0.28 ~ 0.39 in) away from the bolt position.
- M** Upper and lower excessive parts should be appressed. Appearance such as containing bubbles is no object.

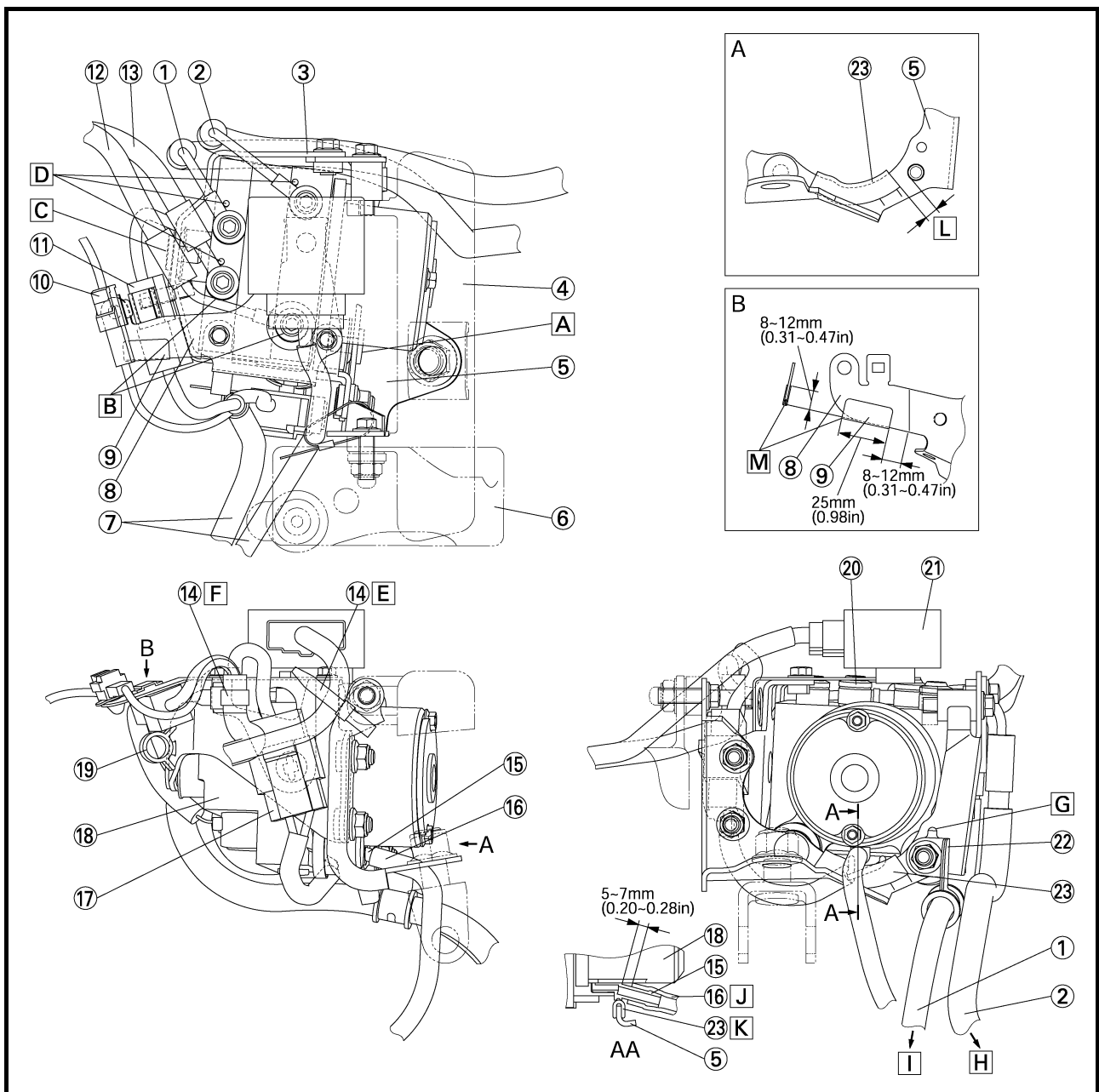

EAS00709

SWINGARM AND DRIVE CHAIN CHECKING THE DRIVE CHAIN

1. Measure:

- Measure the dimension between 15-links on the inner side (a) and outer side (b) of the roller and calculate the dimension between pin centers.
- Dimension (c) between pin centers = (Inner dimension (a) + Outer dimension (b))/2
- 15-link section (c) of the drive chain
Out of specification → Replace the drive chain, front drive sprocket and rear drive sprocket as a set.

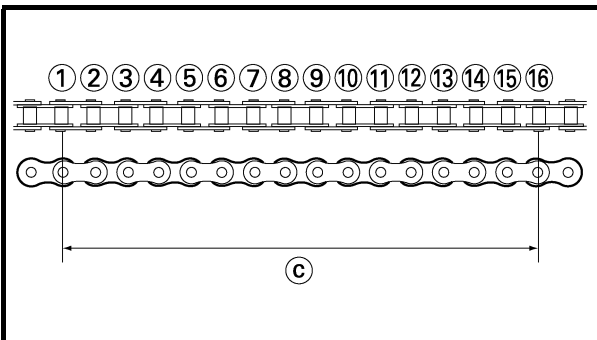
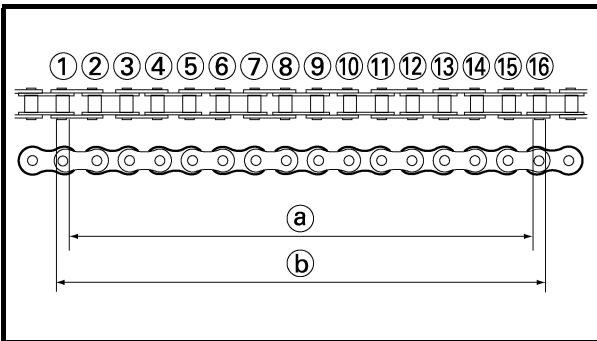

**15-link drive chain section limit
(maximum)
239.3 mm (9.42 in)**

NOTE:

- While measuring the 15-link section, push down on the drive chain to increase its tension.
- Perform this measurement at two or three different places.

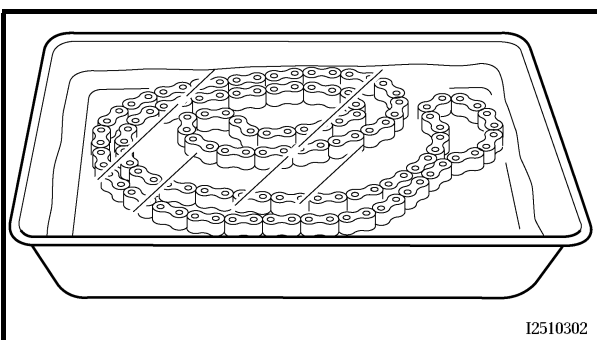
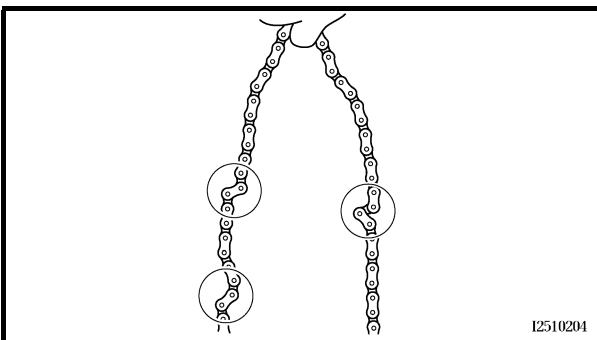

2. Check:

- drive chain
Stiffness → Clean and lubricate or replace.

3. Clean:

- drive chain



- Wipe the drive chain with a clean cloth.
- Put the drive chain in kerosene and remove any remaining dirt.
- Remove the drive chain from the kerosene and completely dry it.

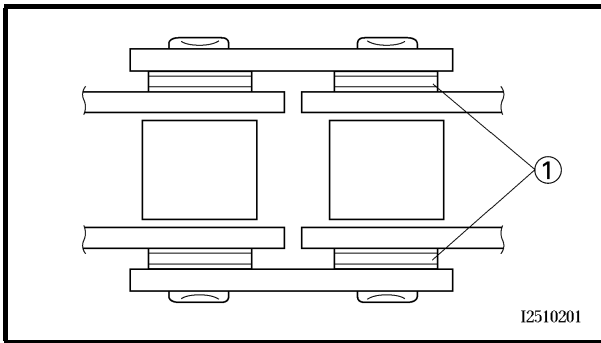

CAUTION:

This motorcycle has a drive chain with small rubber O-rings ① between the drive chain side plates. Never use high-pressure water or air, steam, gasoline, certain solvents (e.g., benzine), or a coarse brush to clean the drive chain. High-pressure methods could force dirt or water into the drive chain's internals, and solvents will deteriorate the O-rings. A coarse brush can also damage the O-rings. Therefore, use only kerosine to clean the drive chain.

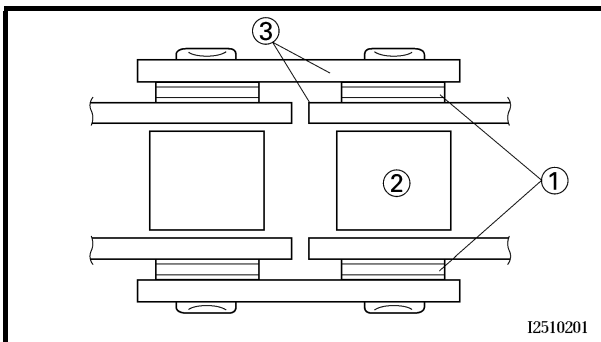

4. Check:

- O-rings ①
Damage → Replace the drive chain.
- drive chain rollers ②
Damage/wear → Replace the drive chain.
- drive chain side plates ③
Damage/wear → Replace the drive chain.
Cracks → Replace the drive chain and make sure that the battery breather hose is properly routed away from the drive chain and below the swingarm.

5. Lubricate:

- drive chain

| | |
|---|--|
|  | <p>Recommended lubricant Engine oil or chain lubricant suitable for O-ring chains</p> |
|---|--|

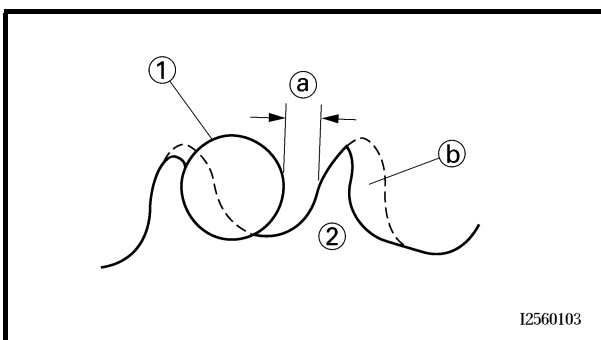

6. Check:

- drive sprocket
 - rear wheel sprocket
More than 1/4 tooth (a) wear → Replace the drive chain sprockets as a set.
Bent teeth → Replace the drive chain sprockets as a set.
- (b) Correct
 (1) Drive chain roller
 (2) Drive chain sprocket

ANTI-LOCK BRAKE SYSTEM (ABS)

ABS OUTLINE

Yamaha ABS features

1. The Yamaha ABS (Anti-Lock Brake System) features a dual electronic control system, which acts on the front and rear brakes independently.
2. The ABS features a compact and lightweight design to help maintain the basic maneuverability of the motorcycle.
3. The hydraulic unit, which is the main component of the ABS, is centrally located on the motorcycle to increase mass centralization.

ABS layout

- | | | |
|---------------------------------|-----------------------|----------------------|
| ① ABS warning light | ⑤ Rear brake caliper | ⑨ Front wheel sensor |
| ② Electronic control unit (ECU) | ⑥ Rear wheel sensor | ⑩ Front disc rotor |
| ③ Fail-safe relay | ⑦ Rear disc rotor | |
| ④ Hydraulic unit | ⑧ Front brake caliper | |

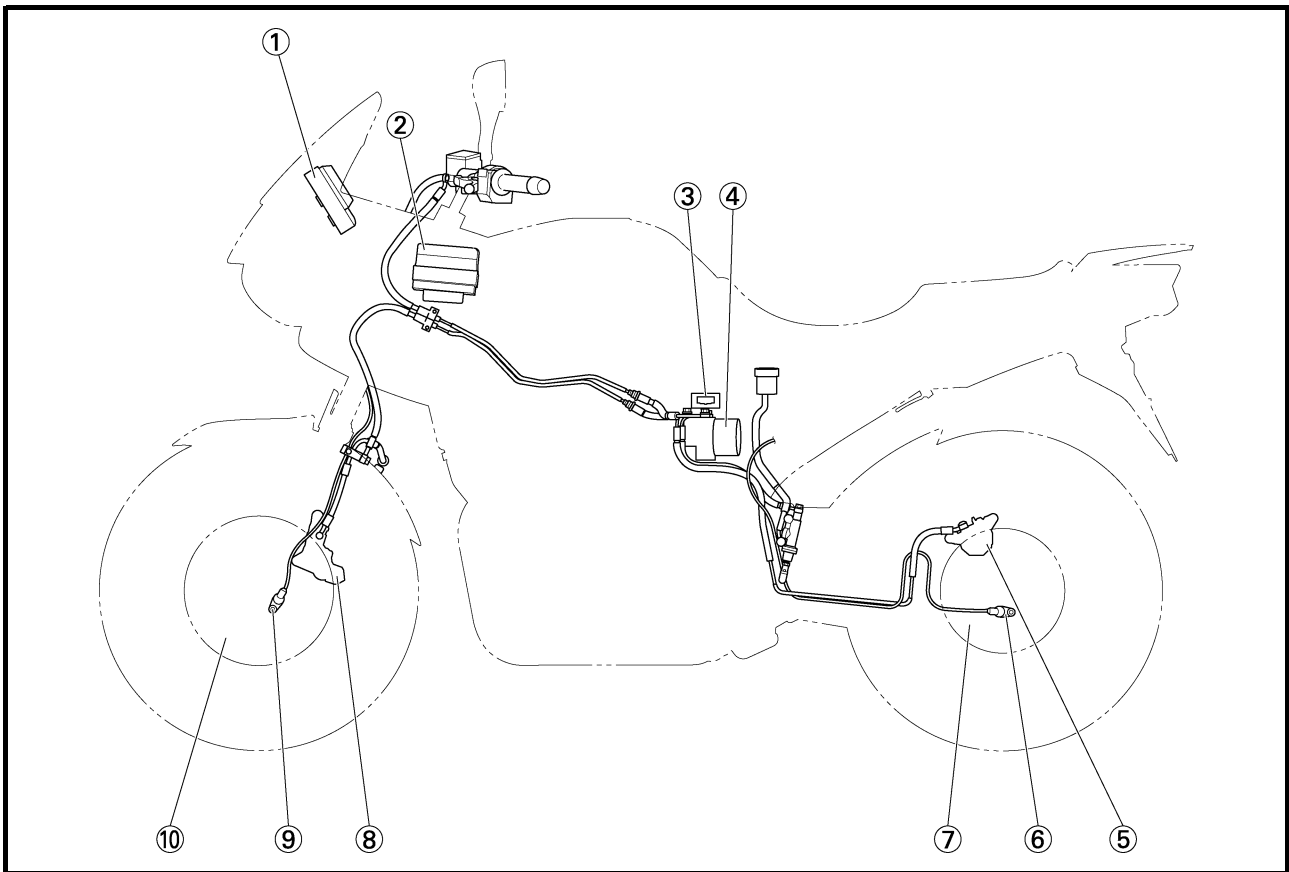

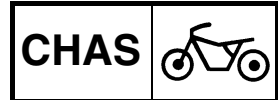

EAS00872

ABS

The operation of the Yamaha ABS brakes is the same as conventional motorcycles, with a brake lever for operating the front wheel brake and a brake pedal for operating the rear wheel brake.

When wheel lockup is detected during emergency braking, hydraulic control is performed by the hydraulic system independently.

EAS00873

Useful terms

- **Wheel speed:**
The rotation speed of the front and rear wheels.
- **Chassis speed:**
The speed of the chassis.
When the brakes are applied, wheel speed and chassis speed are reduced. However, the chassis travels forward by its inertia even though the wheel speed is reduced.
- **Brake force:**
The force applied by braking to reduce the wheel speed.
- **Wheel lock:**
A condition that occurs when the rotation of one or both of the wheels has stopped but the motorcycle continues to travel.
- **Side force:**
The force on the tires which supports the motorcycle when cornering.

- Slip ratio:
When the brakes are applied, slipping occurs between the tires and the road surface. This causes a difference between the wheel speed and the chassis speed. Slip ratio is the value that shows the rate of wheel slippage and is defined by the following formula.

$$\text{Slip ratio} = \frac{\text{Chassis speed} - \text{Wheel speed}}{\text{Chassis speed}} \times 100 (\%)$$

- 0%: There is no slip between the wheel and the road surface. The chassis speed is equal to the wheel speed.
- 100%: The wheel speed is "0", but the chassis is moving (i.e., wheel lock).

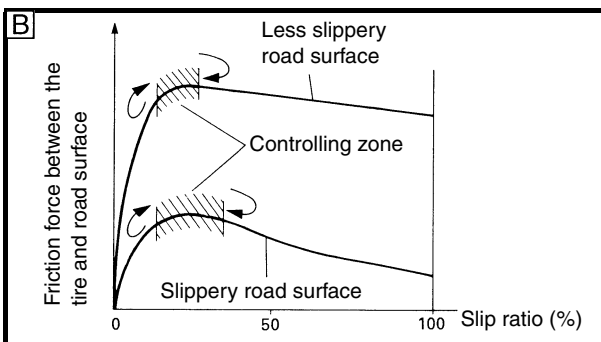
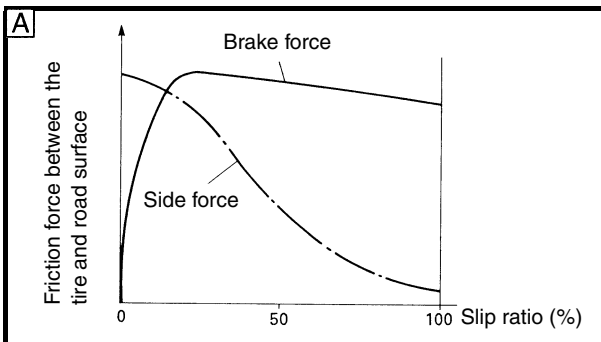

EAS00874

Brake force and motorcycle stability

When the brake pressure is increased, wheel speed is reduced. Slip occurs between the tire and the road surface and brake force is generated. The limit of this brake force is determined by the friction force between the tire and the road surface and is closely related to wheel slippage. Wheel slippage is represented by the slip ratio.

Therefore, side force is also closely related to wheel slippage. See figure [A]. If the brakes are applied while keeping the proper slip ratio, it is possible to obtain the maximum brake force without losing much side force.

ABS allows full use of the tire capabilities even on slippery road surfaces or less slippery road surfaces. See figure [B].

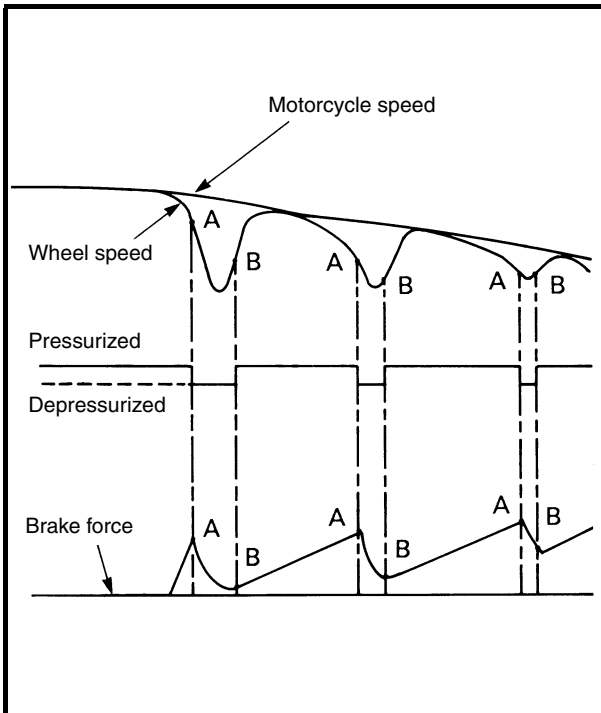

EAS00875

Wheel slip and hydraulic control

The ECU (ABS) calculates the wheel speed of each wheel according to the rotation signal received from the front and rear wheel sensors. In addition, the ECU (ABS) calculates the motorcycle chassis speed and the rate of speed reduction based on the wheel speed values.

The difference between the chassis speed and the wheel speed calculated in the slip ratio formula is equal to the wheel slip. When the wheel has a tendency to lock, the wheel speed is suddenly reduced. When the wheel slip and the wheel speed reduction rate exceed the preset values, the ECU (ABS) determines that the wheel has a tendency to lock.

If the slip is large and the wheel has a tendency to lock (point A in the figure), the ECU (ABS) reduces the brake fluid pressure in the brake caliper and increases the pressure of the brake fluid in the brake caliper when the tendency to lock has diminished (point B in the figure).

EAS00876

ABS operation and motorcycle control

If the ABS starts operating, there is a tendency of the wheel to lock, and the motorcycle is approaching the limit of control. To make the rider aware of this condition, the ABS has been designed to generate a reaction-force pulsating action in the brake lever or brake pedal.

NOTE:

When the ABS is activated, a pulsating action may be felt at the brake lever or brake pedal, but this does not indicate a malfunction.

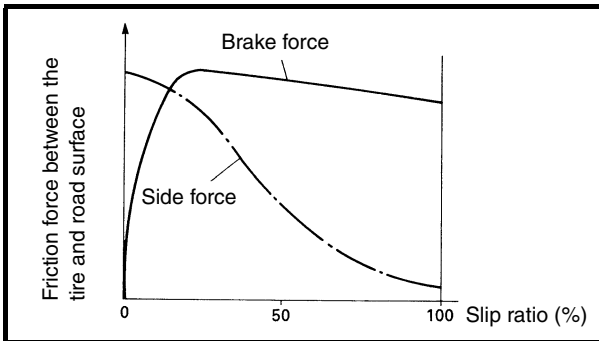

The higher the cornering force on a tire, the less traction there is available for braking. This is true whether the motorcycle is equipped with an ABS or not. Therefore, sudden braking while cornering is not recommended. Excessive cornering force, which an ABS cannot prevent, could cause the tire to slip sideways.

⚠ WARNING

The braking of the motorcycle, even in the worst case, is principally executed when the motorcycle is advancing straight ahead. During a turn, sudden braking is liable to cause a loss of traction of the tires. Even in motorcycles equipped with an ABS, overturning of the motorcycle cannot be prevented if it is braked suddenly.

The ABS functions to prevent the tendency of the wheel to lock by controlling the brake hydraulic pressure. But, if there is a tendency of the wheel to lock on a slippery road surface, due to engine braking, the ABS may not be able to prevent the wheel from locking.

⚠ WARNING

The ABS controls only the tendency of the wheel to lock caused by applying the brakes. The ABS cannot prevent wheel lock on slippery surfaces, such as ice, when it is caused by engine braking, even if the ABS is operating.

EAS00877

Electronic ABS features

The Yamaha ABS (Anti-lock Brake System) has been developed with the most advanced electronic technology.

The ABS control is processed with good response providing various travel conditions for motorcycles.

The ABS also includes a highly developed self-diagnostic function. The ABS detects any problem conditions and allows normal braking even if the ABS is not operating properly.

When this occurs, the ABS warning light on the meter assembly comes on.

The ABS stores the malfunction codes in the memory of the ECU (ABS) for easy problem identification and troubleshooting.

ABS block diagram

- | | | |
|------------------------------|-------------------------------|----------------------|
| ① Rear brake master cylinder | ⑥ Hydraulic control valve | ⑪ Rear wheel sensor |
| ② Hydraulic unit | ⑦ Front brake master cylinder | ⑫ Front wheel sensor |
| ③ Hydraulic pump | ⑧ Rear brake caliper | ⑬ ABS warning light |
| ④ ABS motor | ⑨ Front brake caliper | |
| ⑤ Buffer chamber | ⑩ ECU (ABS) | |

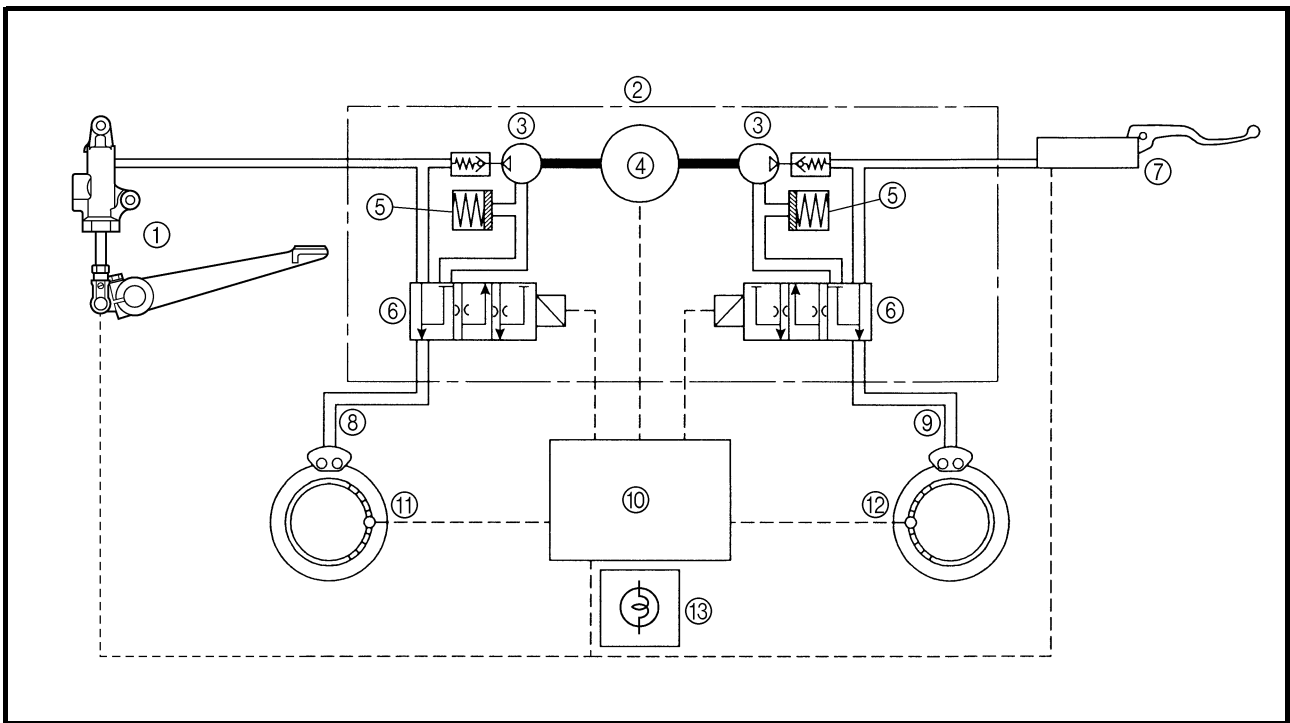

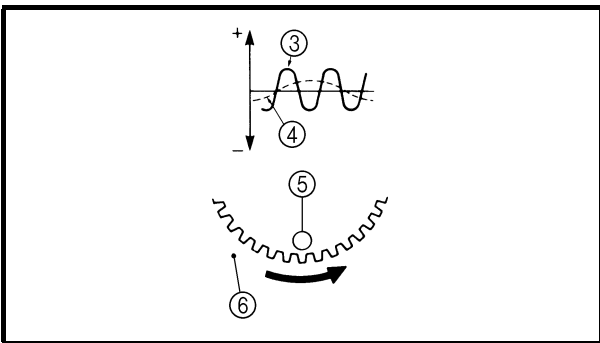
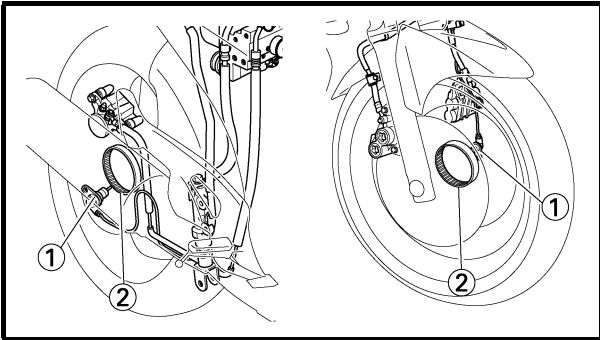

EAS000878

ABS component functions

• Wheel sensors and sensor rotors

Wheel sensors ① detect the wheel rotation speed and transmit the wheel rotation signal to the ECU (ABS).

Each wheel sensor is composed of a permanent magnet and a coil. The wheel sensors are installed in the sensor housing for each wheel. Sensor rotors ② are pressed in the inner side of the front and rear wheel hubs and rotate with the wheels. The sensor rotors have 44 serrations inside and are installed close to the wheel sensors. As the distance changes between the top and bottom of the serrations with the rotation of the wheels, inductive electromotive force is generated in the wheel sensors. Wheel rotation speed is detected based on the frequency of this alternating voltage.

- ③ At high speed
- ④ At low speed
- ⑤ Wheel sensor
- ⑥ Sensor rotor

• ABS warning light

The ABS warning light comes on to warn the rider if a malfunction in the ABS occurs.

When the main switch is set to “ON”, the ABS warning light comes on for 2 seconds to check if the ABS warning light is disconnected and to check if the ABS is operating properly, then goes off.

CAUTION:

If the rear wheel is raced with the motorcycle on the centerstand, the ABS warning light may flash or come on. If this occurs, set the main switch to “OFF”, then back to “ON”. The ABS operation is normal if the ABS warning light comes on for 2 seconds, then goes off.

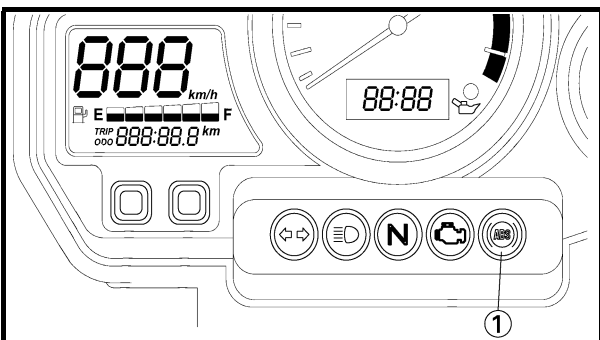

- ① ABS warning light

ANTI-LOCK BRAKE SYSTEM (ABS)

CHAS

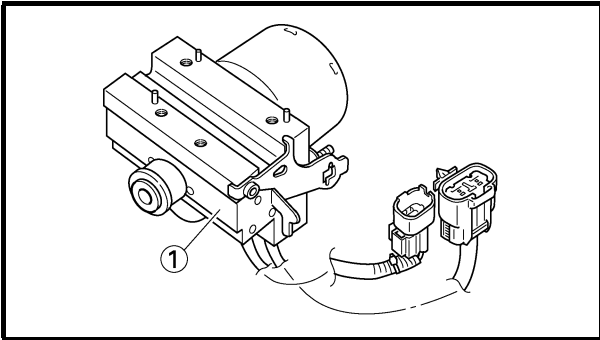

EAS00879

• Hydraulic unit

The hydraulic unit ① is composed of a hydraulic control valve (solenoid valve, flow control valve), a buffer chamber, and a hydraulic pump for each brake and an ABS motor. The hydraulic unit adjusts the front and rear wheel brake fluid pressure to control the wheel rotation speed according to signals transmitted from the ECU (ABS).

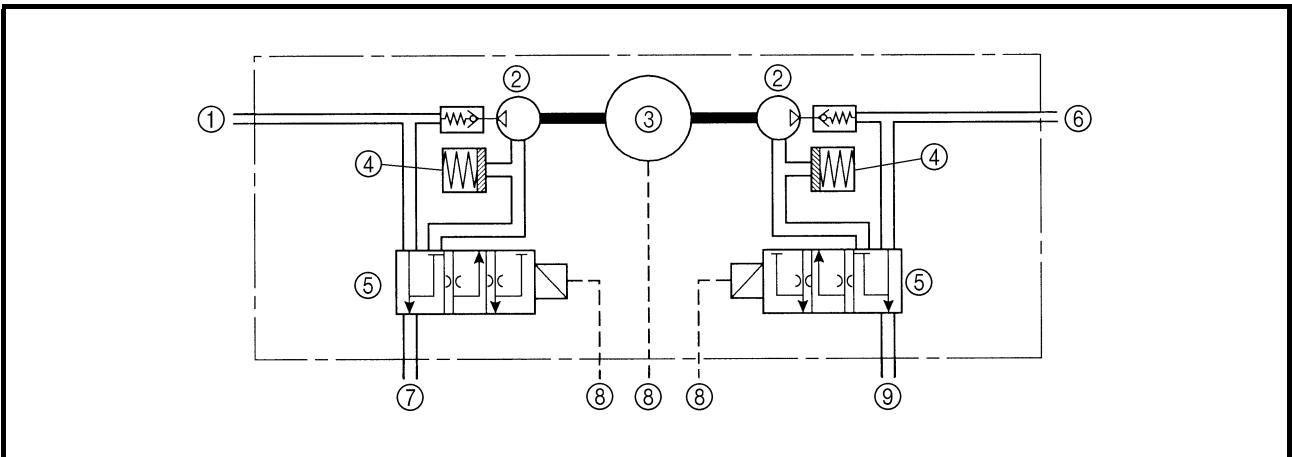
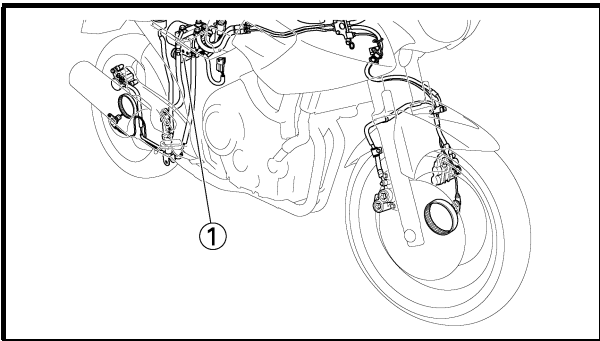

- ① To rear brake master cylinder
- ② Hydraulic pump
- ③ ABS motor
- ④ Buffer chamber
- ⑤ Hydraulic control valve

- ⑥ To front brake master cylinder
- ⑦ To the rear brake caliper
- ⑧ To the ECU (ABS)
- ⑨ To the front brake caliper

- Hydraulic control valve
The hydraulic control valve is composed of a flow control valve and solenoid valve. When the ABS is activated, the flow control valve regulates the flow of brake fluid to each brake and the solenoid valve decreases and increases the brake fluid pressure.

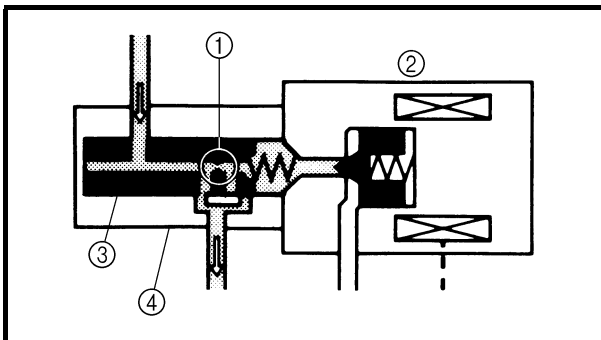

- 1) When the brakes are operated normally, the solenoid valve ② is closed, the spool ③ of the flow control valve does not move, and the hydraulic line between the brake master cylinder and brake caliper is open.

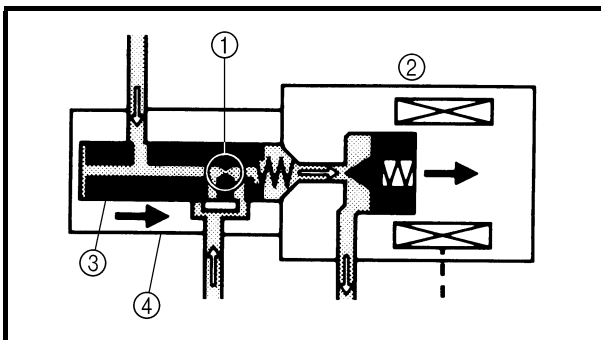

- 2) When the ABS is activated, the solenoid valve ② is opened by the power supplied from the ECU (ABS) signals to decrease the brake fluid pressure and the spool ③ of the flow control valve is moved toward the solenoid valve.

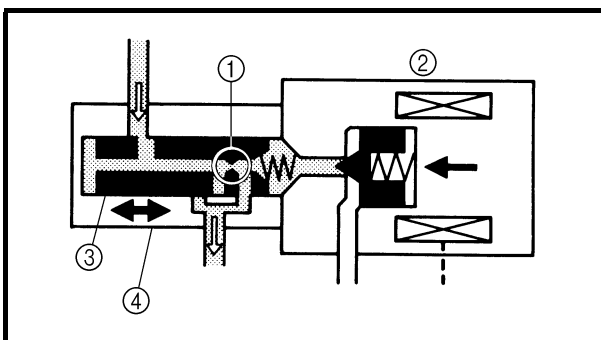

- 3) When the ECU (ABS) stops transmitting signals to decrease the brake fluid pressure, the solenoid valve ② closes and the brake fluid is pressurized again. Pressurizing the brake fluid again, while the ABS is activated, limits the flow of the brake fluid with the movement of the flow control valve spool ③ and provides a gradual pressure increase.

- ① Orifice
- ② Solenoid valve
- ③ Spool
- ④ Flow control valve

ANTI-LOCK BRAKE SYSTEM (ABS)

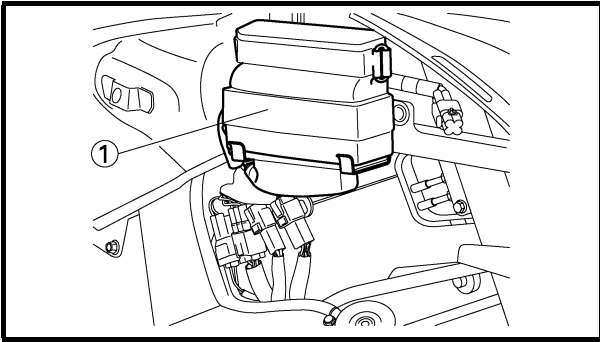
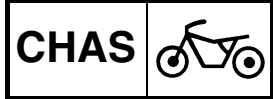

- **Electronic control unit (ECU)**

The ECU (ABS) ① controls the ABS and is installed inside the right cowling. To protect the ECU (ABS) from water damage, it is protected by a cover ②.

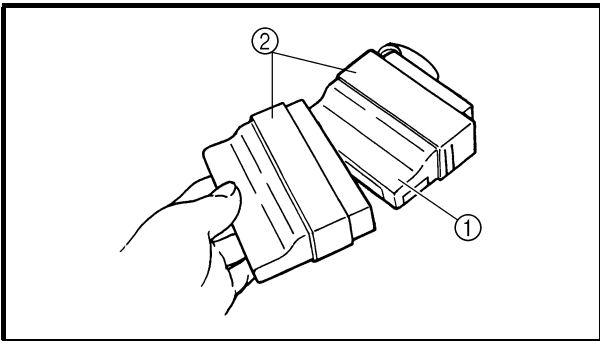

ANTI-LOCK BRAKE SYSTEM (ABS)

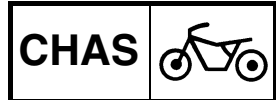

As shown in the block diagram below, the ECU (ABS) receives wheel sensor signals from the front and rear wheels and also receives signals from other monitor circuits. Both a main microcomputer and a sub microcomputer are installed in the ECU (ABS) to provide mutual monitoring.

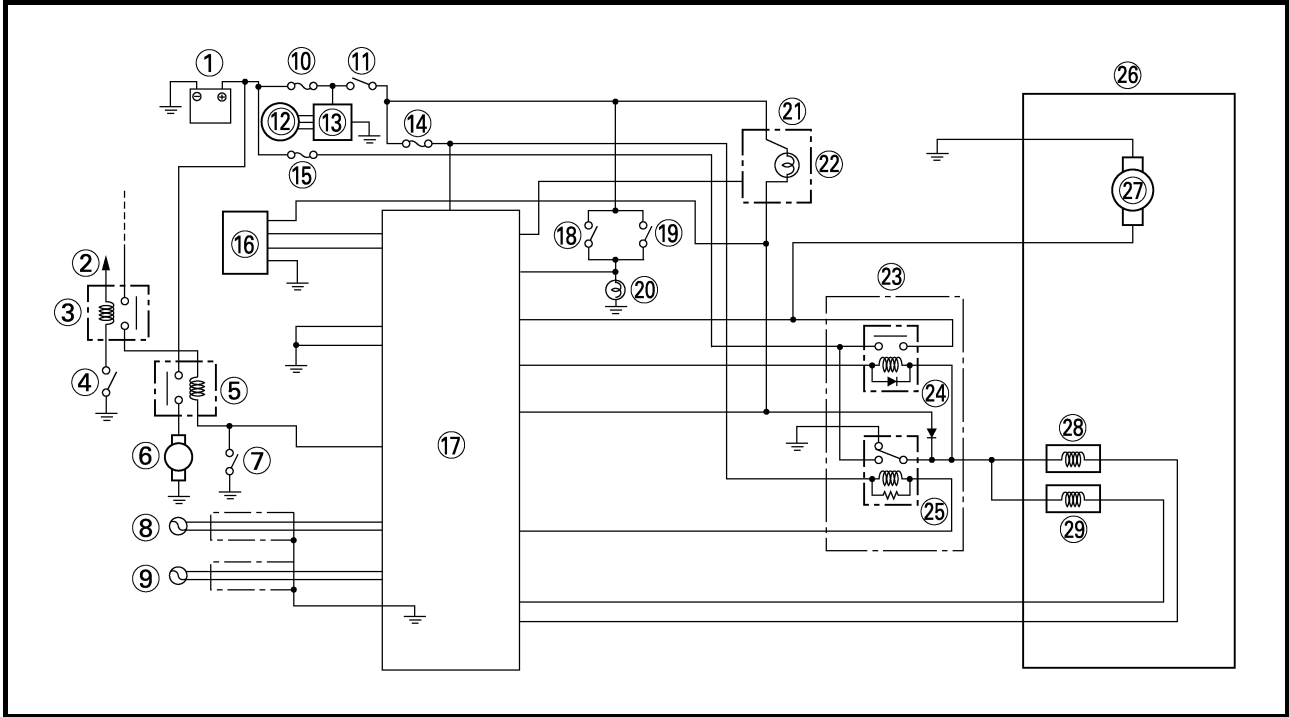

- | | | |
|----------------------------------|----------------------------|---------------------|
| ① Battery | ⑪ Main switch | ⑳ Meter assembly |
| ② Engine stop switch | ⑫ Generator | ㉑ ABS warning light |
| ③ Starting circuit cut-off relay | ⑬ Rectifier/regulator | ㉒ Fail-safe relay |
| ④ Sidestand switch | ⑭ ABS fuse | ㉓ ABS motor relay |
| ⑤ Starter relay | ⑮ ABS motor fuse | ㉔ Solenoid relay |
| ⑥ Starter motor | ⑯ ABS test coupler | ㉕ Hydraulic unit |
| ⑦ Start switch | ⑰ ECU (ABS) | ㉖ ABS motor |
| ⑧ Front wheel sensor | ⑱ Rear brake light switch | ㉗ Front solenoid |
| ⑨ Rear wheel sensor | ㉒ Front brake light switch | ㉘ Rear solenoid |
| ⑩ Main fuse | ㉓ Tail/brake light | |

The necessary actions are confirmed by the motor monitor circuit and control signals are transmitted to the hydraulic unit and fail-safe relay.

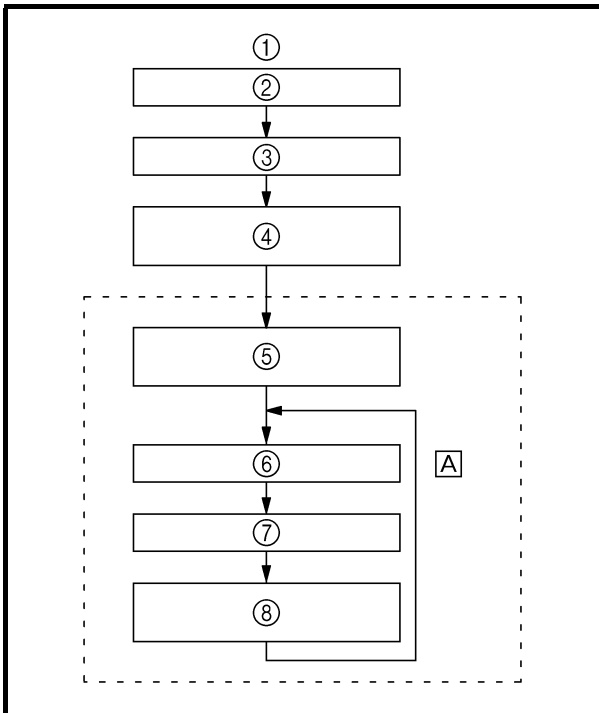

•ABS control operation

The ABS control operation performed in the ECU (ABS) is divided into the following two parts.

- Hydraulic control
- Self-diagnosis

These operations are performed once every 8/1,000 of a second. When a failure is detected in the ABS, a malfunction code is stored in the memory of the ECU (ABS) for easy problem identification and troubleshooting.

NOTE:

Some types of failures are not recorded in the memory of the ECU (ABS) (e.g., a drop in battery voltage).

- ① Software operation flow
- ② Set the main switch to "ON".
- ③ Initialize
- ④ Self-diagnosis (when static)
- ⑤ Self-diagnosis (when riding)
- ⑥ Receive signals
- ⑦ Control operation
- ⑧ Depressurize/pressurize

A 8/1,000 of a second

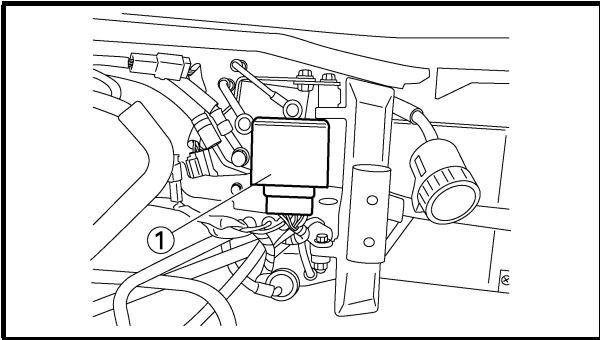

• Fail-safe relay

The fail-safe relay controls the power supply of the hydraulic unit and is located beside the hydraulic unit.

① Fail-safe relay

Composition and operation

The fail-safe relay is composed of the solenoid relay ① and ABS motor relay ②. The solenoid relay is activated (continuous) by signals transmitted from the ECU (ABS). As a result, the solenoid valve ③ can be operated.

If a malfunction occurs in the circuit, the solenoid relay is deactivated and it becomes impossible for the solenoid valve to reduce the hydraulic pressure of the brake fluid and normal braking is resumed.

The ABS motor relay is also activated by signals transmitted from the ECU (ABS) and operates simultaneously when the ABS starts to reduce the hydraulic pressure of the brake fluid.

If the solenoid relay is turned off, the motor relay is also deactivated and the motor stops operating if there is a malfunction.

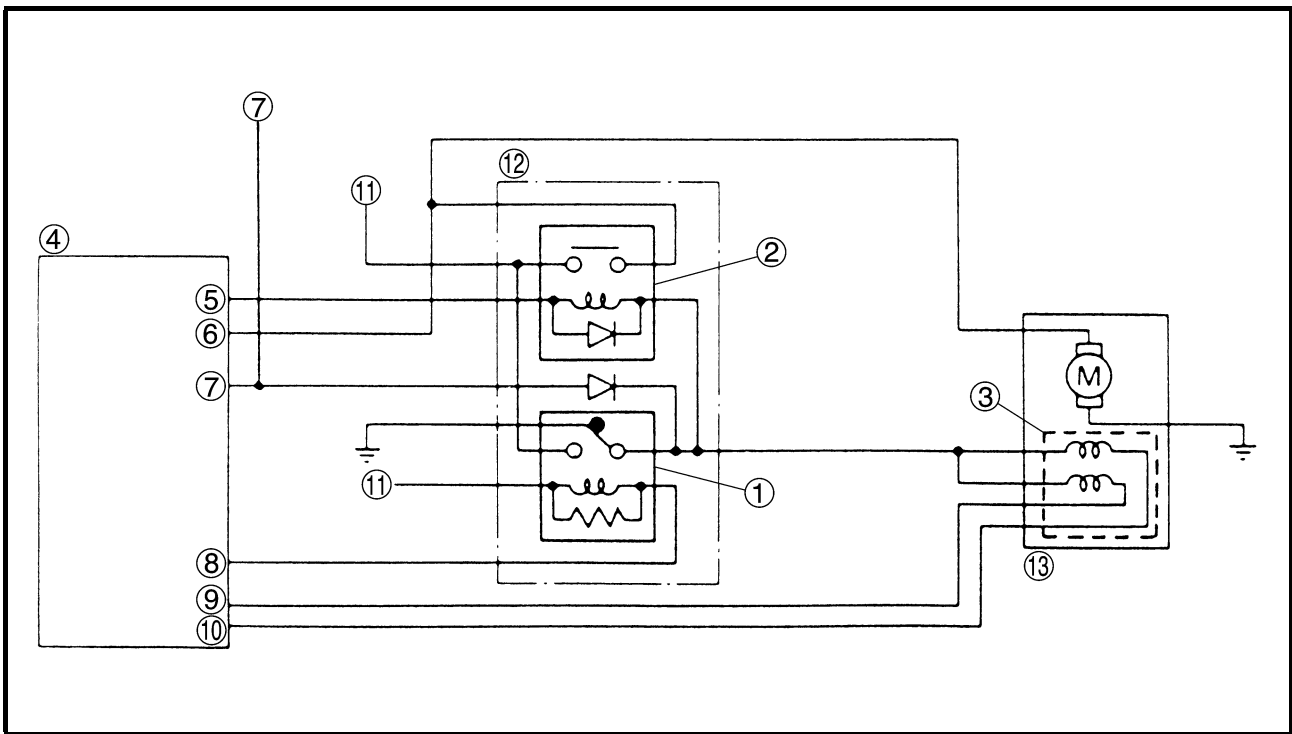

- | | | |
|-------------------------------|------------------------|-------------------|
| ① Solenoid relay | ⑥ Pump motor monitor | ⑪ Power |
| ② ABS motor relay | ⑦ ABS warning light | ⑫ Fail-safe relay |
| ③ Solenoid valve | ⑧ Fail-safe relay coil | ⑬ Hydraulic unit |
| ④ Electric control unit (ECU) | ⑨ Rear solenoid | |
| ⑤ Pump motor relay coil | ⑩ Front solenoid | |

ABS operation

The ABS hydraulic circuit consists of two systems: the front wheel and rear wheel. The following describes the front system only.

• Normal braking (ABS not activated)

When the ABS is not activated port D (11) of the solenoid valve is closed because a control signal has not been transmitted from the ECU (ABS) and port A (7) and port B (9) of the flow control valve are open. Therefore, when the brake lever is squeezed, the hydraulic pressure in the brake master cylinder increases and the brake fluid is sent to the brake caliper via port A and port B.

At this time, the inlet and outlet check valves of the pump close the lines and brake fluid is not sent. As a result, the brake master cylinder directly pressurizes the brake caliper during normal braking. When the brake lever is released, the brake fluid in the brake caliper returns to the brake master cylinder via port A and port B.

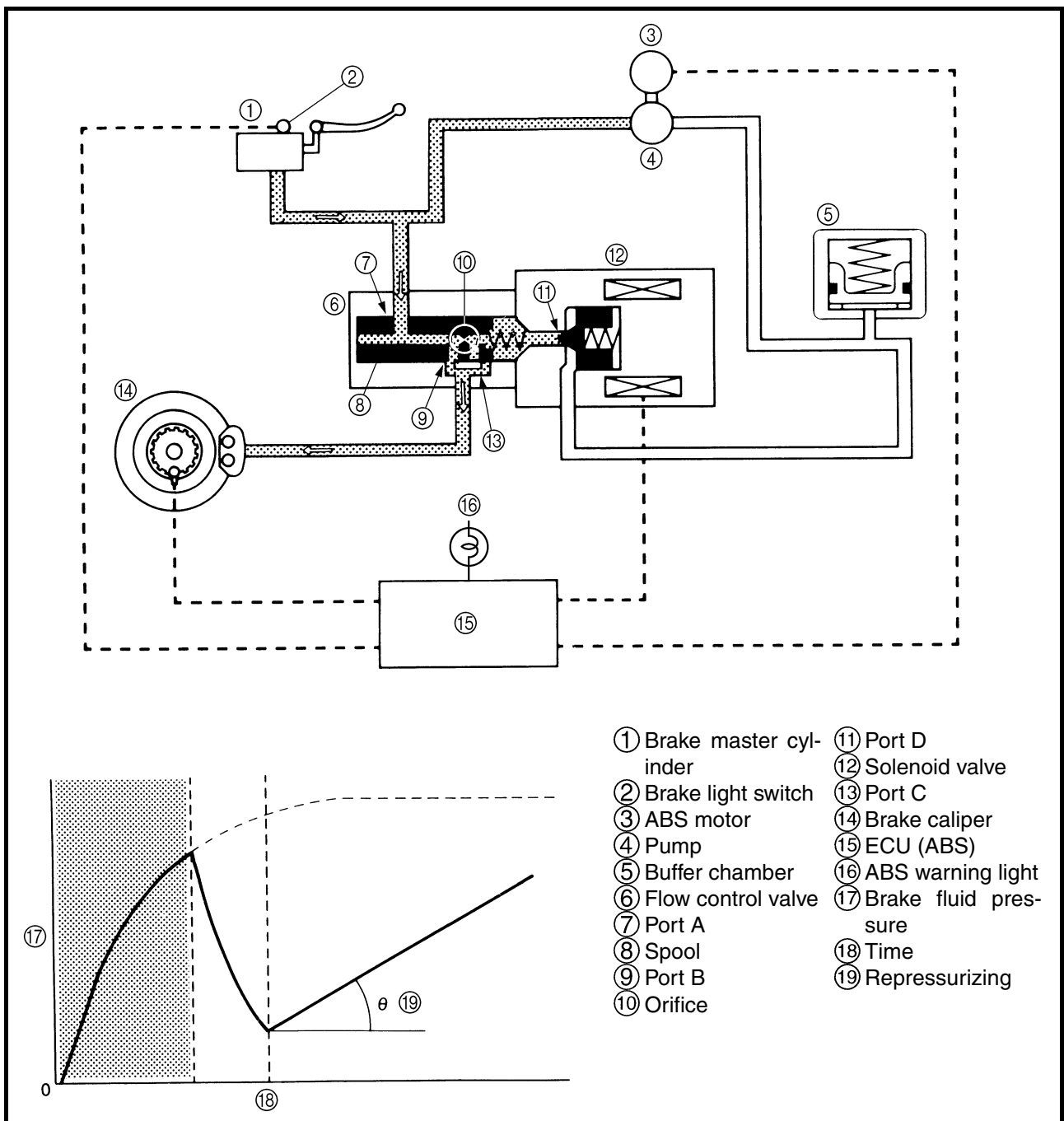

• Emergency braking (ABS activated)

1) Depressurized state

When the front wheel is about to lockup, port D ⑪ of the solenoid valve is opened by the “depressurization” signal transmitted from the ECU (ABS). When this occurs, the spool of the flow control valve compresses the return spring to close port B ⑨. Brake fluid that has entered through port A ⑦ is restricted by the orifice ⑩ and the brake fluid is sent to the brake caliper via port C ⑬ and port D ⑪, and the buffer chamber. As a result, the hydraulic pressure in the brake caliper is reduced.

The brake fluid stored in the buffer chamber is pumped back to the brake master cylinder by the fluid pressure pump linked to the pump motor.

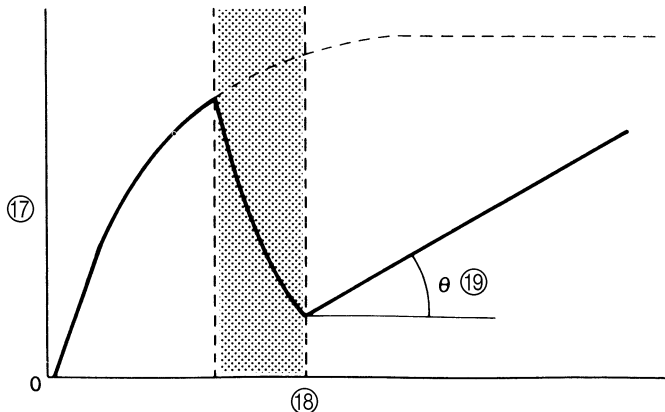
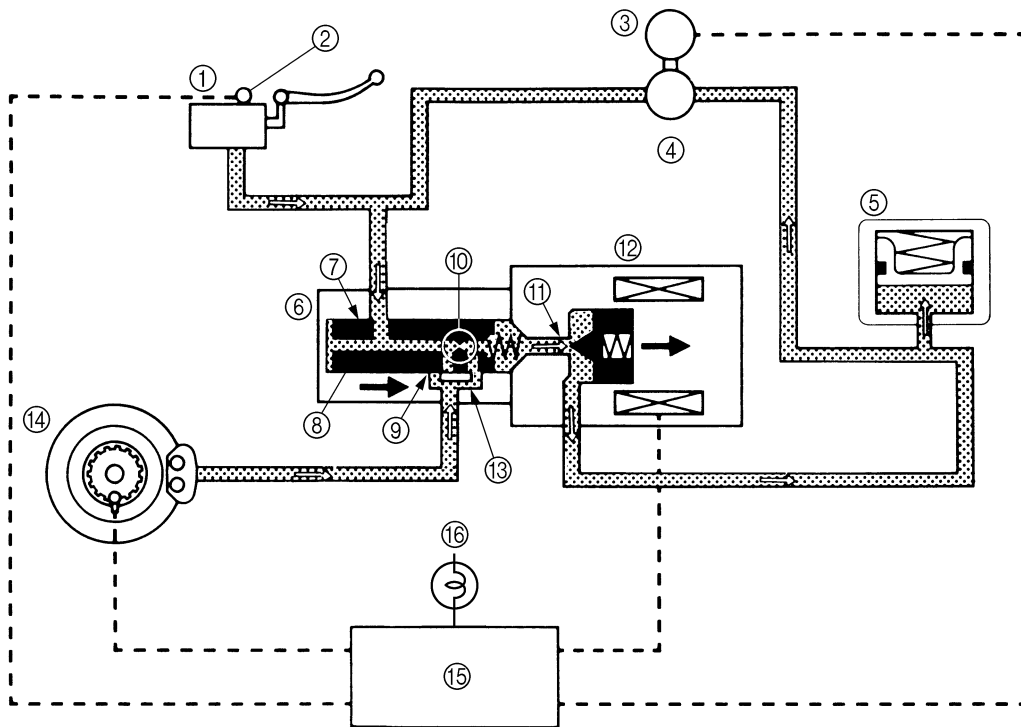

- | | |
|-------------------------|------------------------|
| ① Brake master cylinder | ⑪ Port D |
| ② Brake light switch | ⑫ Solenoid valve |
| ③ ABS motor | ⑬ Port C |
| ④ Pump | ⑭ Brake caliper |
| ⑤ Buffer chamber | ⑮ ECU (ABS) |
| ⑥ Flow control valve | ⑯ ABS warning light |
| ⑦ Port A | ⑰ Brake fluid pressure |
| ⑧ Spool | ⑱ Time |
| ⑨ Port B | ⑲ Repressurizing |
| ⑩ Orifice | |

2) Pressurized state

Port D (11) is closed by the “pressurization” signal transmitted from the ECU (ABS). Before this occurs, the spool of the flow control valve has compressed the return spring to close port B (9). Brake fluid that has entered through port A (7) is further restricted by the orifice (10) and the brake fluid is sent to the brake calipers via port A (7) and port C (13). At this time, the brake is pressurized at a constant speed regardless of the brake fluid pressure level since restriction of port A (7) changes so that a constant pressure difference is maintained between chamber A (20) and chamber B (21) of the flow control valve.

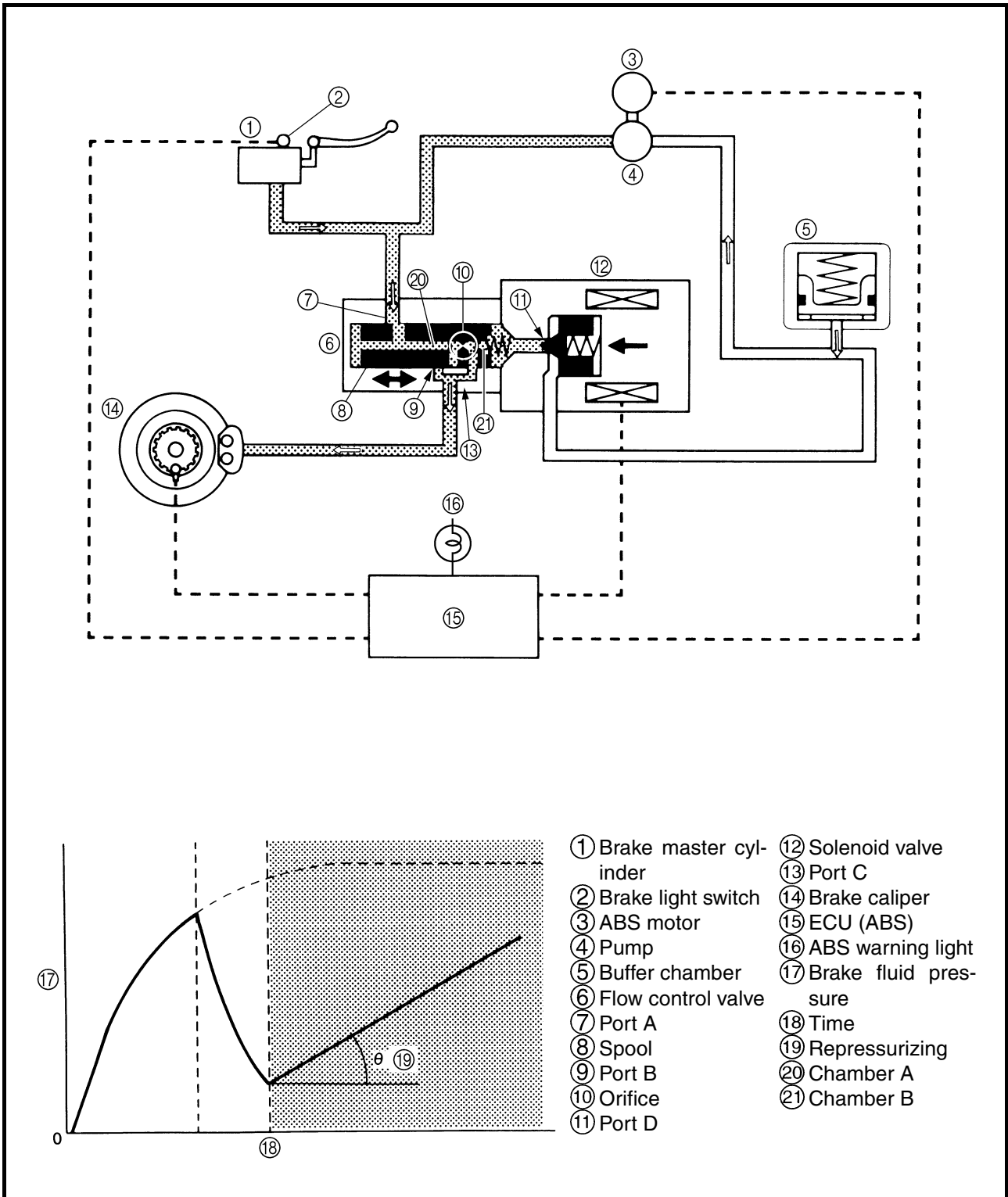

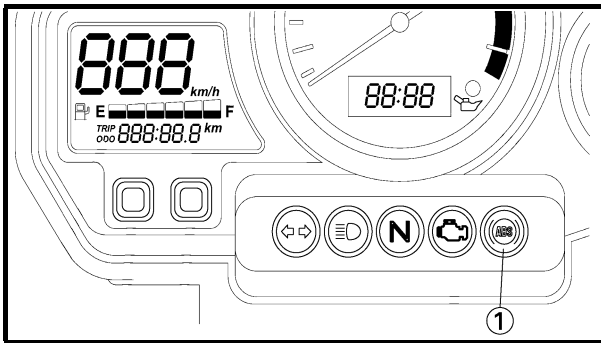

EAS00880

Self-diagnosis function

• ABS warning light

The ABS warning light ① comes on when a malfunction is detected by the ABS self-diagnosis. It is located in the meter assembly.

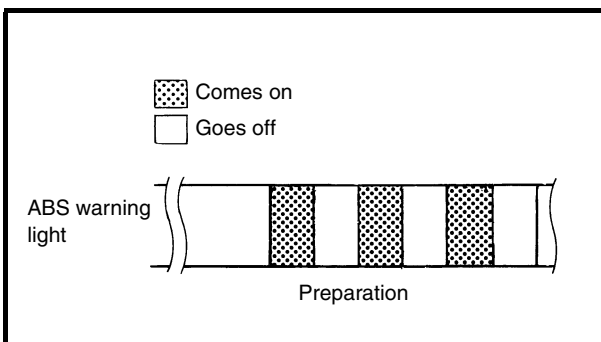
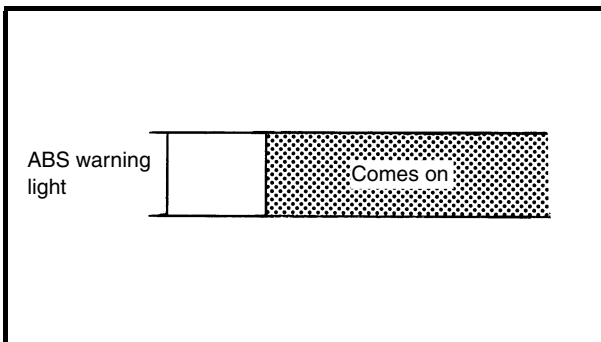
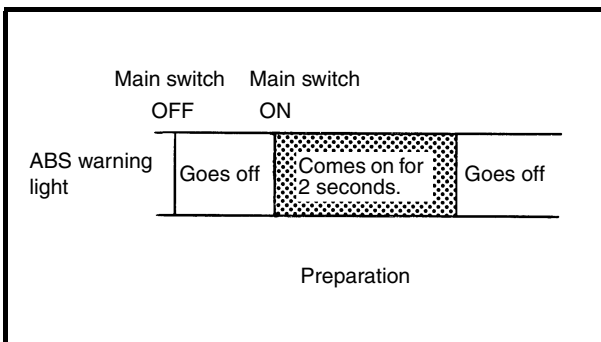

• Instances when the ABS warning light comes on

- 1) The ABS warning light comes on when the main switch is set to "ON".
The ABS warning light comes on for 2 seconds while the ABS is performing a self-diagnosis, then goes off if there are no problems.
- 2) The ABS warning light comes on while riding.
If the ABS warning light comes on while riding, a malfunction has been detected in the ABS. The ABS hydraulic control will not be performed. The ABS will have recourse to manual braking if this occurs.
- 3) The ABS warning light flashes while riding.
If the ABS warning light flashes while riding, there is no problem with the function of the ABS. However, the ECU (ABS) input has unstable factors. (For details, refer to "TROUBLESHOOTING".)

NOTE: _____
The ABS warning light comes on or flashes if the motorcycle is ridden with the test coupler adaptor connected to the test coupler.

ANTI-LOCK BRAKE SYSTEM (ABS)

CHAS

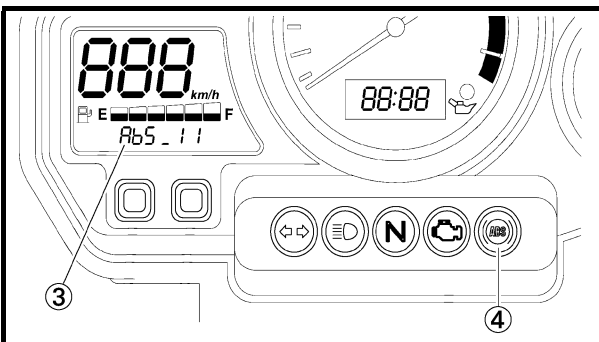
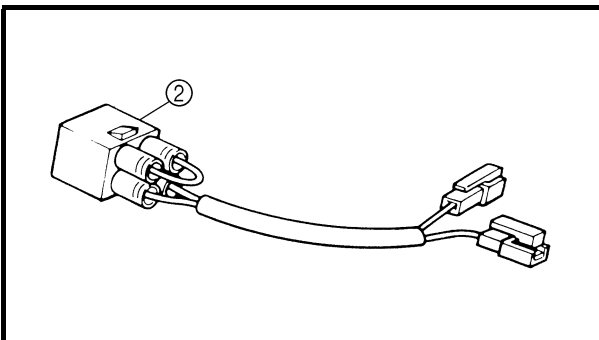
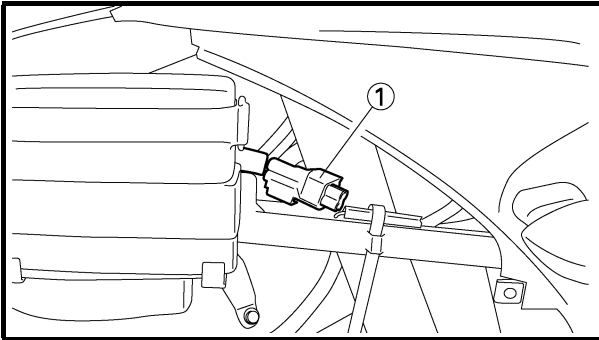

- 4) The ABS warning light (4) flashes and multifunction code (3) is indicated on the multifunction display when a test coupler adaptor (2) is connected to the 4-pin test coupler (1) for troubleshooting the ABS.

The 4-pin test coupler can be accessed by removing the side cowling (right).

When the test coupler adaptor is connected to the 4-pin test coupler, the ABS warning light starts flashing and the multifunction display indicates all the multifunction codes recorded in the ECU (ABS).



Test coupler adaptor
90890-03149

NOTE:

The ABS warning light comes on or flashes if the motorcycle is ridden with the test coupler adaptor connected to the test coupler.

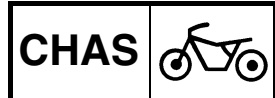
**Cautions for operation****ABS warning light:**

- When the main switch is set to "ON", the ABS warning light comes on for 2 seconds, then goes off.
- If the ABS warning light comes on while riding, stop the motorcycle, and then set the main switch to "OFF", then set the main switch to "ON". The ABS operation is normal if the ABS warning light comes on for 2 seconds, then off.
- If the rear wheel is raced with the motorcycle on the centerstand, the ABS warning light may flash or come on. If this occurs, set the main switch to "OFF", then back to "ON". The ABS operation is normal if the ABS warning light comes on for 2 seconds, then goes off.
- The ABS operation is normal if the ABS warning light flashes.
- Even if the ABS warning light remains on and does not go off or if it comes on after riding, conventional braking performance of the motorcycle is maintained.

ABS function:

- A brake system in which the hydraulic control has been performed by the ABS alerts a rider that the wheels had a tendency to lock by generating a reaction-force pulsating action in the brake lever or brake pedal. When the ABS is activated, the grip between the road surface and tires is close to the limit. The ABS cannot prevent wheel lock* on slippery surfaces such as ice, when it is caused by engine braking, even if the ABS is activated.
- The ABS is not designed to shorten the braking distance or improve the cornering performance.
- Depending on the road conditions, the braking distance may be longer compared to that of vehicles not equipped with an ABS. Therefore, ride at a safe speed and keep a safe distance between yourself and other vehicles.
- The braking of the motorcycle, even in the worst case, is principally executed when the motorcycle is advancing straight ahead. During a turn, sudden braking is liable to cause a loss of traction of the tires. Even motorcycles equipped with an ABS cannot be prevented from falling over if braked suddenly.
- The ABS does not work when the main switch is set to "OFF". The conventional braking function can be used.

*Wheel lock: A condition that occurs when the rotation of one or both of the wheels has stopped but the motorcycle continues to travel.

EAS00882

ABS COMPONENTS

- | | |
|--|--|
| ① Front brake hose (front brake master cylinder to hydraulic unit) | ⑧ Rear brake hose (hydraulic unit to rear brake caliper) |
| ② ABS test coupler | ⑨ Rear brake hose (rear brake master cylinder to hydraulic unit) |
| ③ ABS warning light | ⑩ Hydraulic unit |
| ④ Front brake hose (hydraulic unit to front brake caliper) | ⑪ Rear wheel sensor rotor |
| ⑤ Front wheel sensor | ⑫ Rear wheel sensor |
| ⑥ Front wheel sensor rotor | ⑬ Fuse box |
| ⑦ Electronic control unit (ECU) | ⑭ Fail-safe relay |

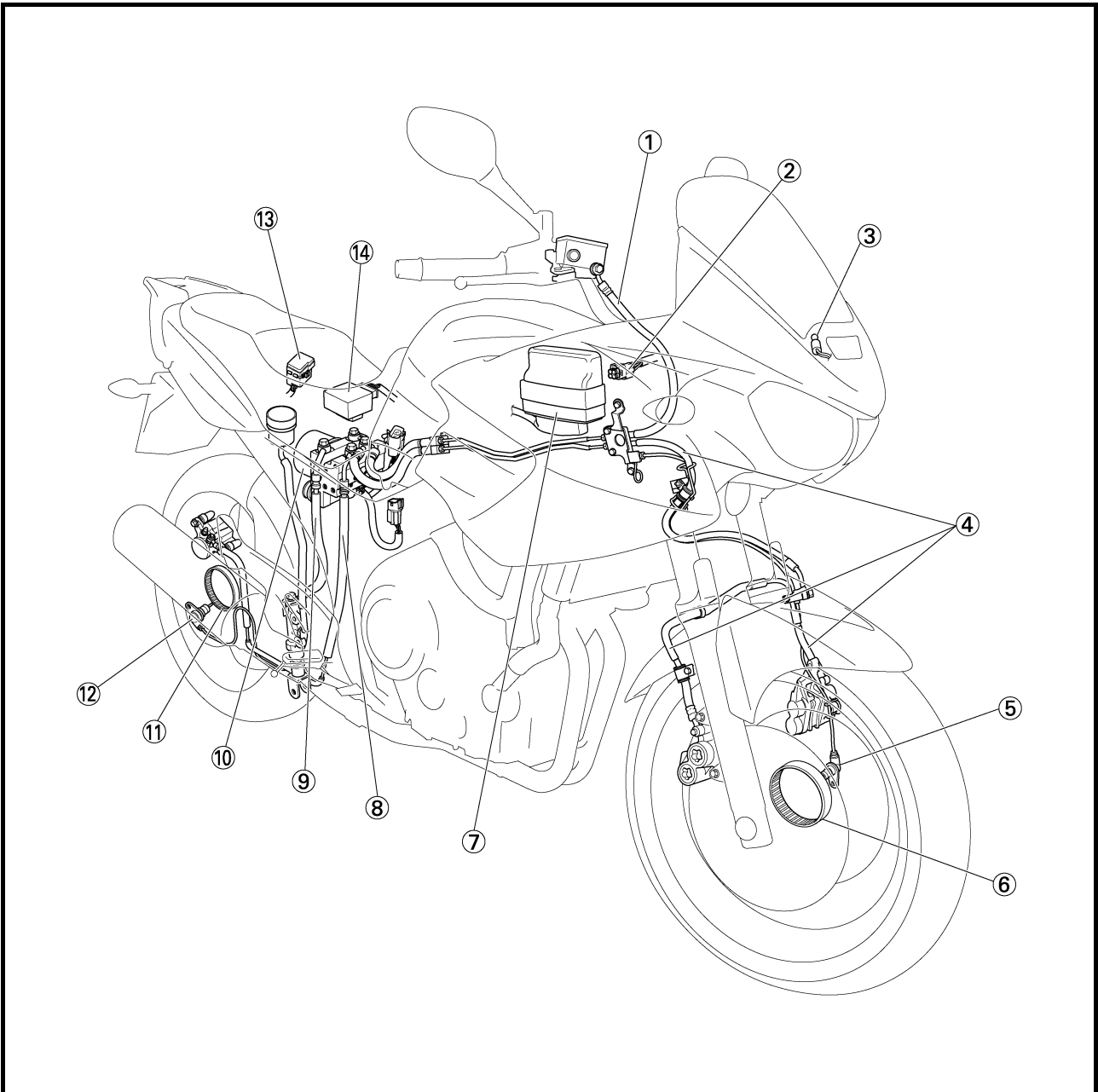

EAS00889

FRONT WHEEL SENSOR AND SENSOR ROTOR

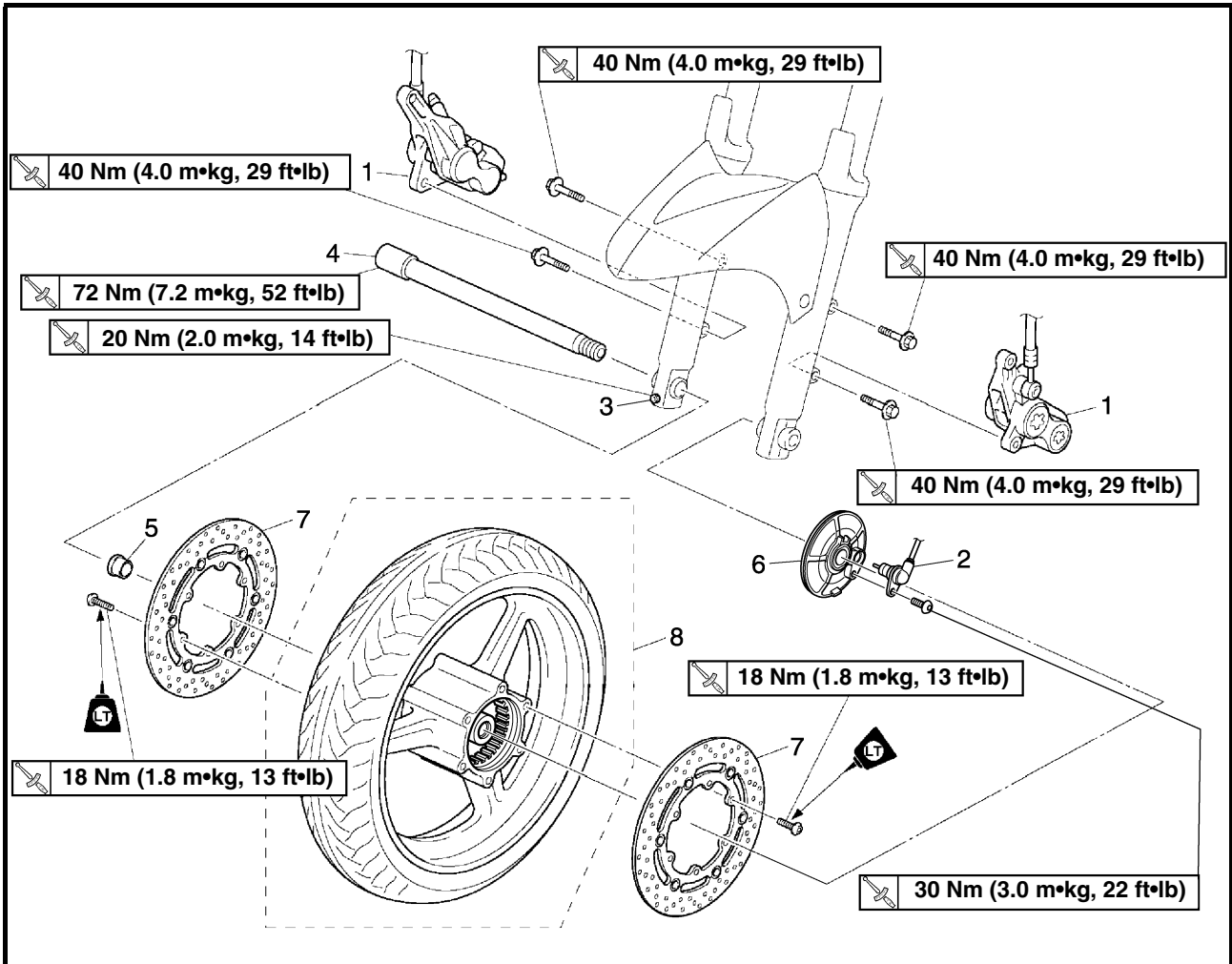

| Order | Job/Part | Q'ty | Remarks |
|-------|---|------|--|
| | Removing the front wheel sensor and sensor rotor | | Remove the parts in the order listed. NOTE: _____ Place the motorcycle on a suitable stand so that the front wheel is elevated. |
| 1 | Brake caliper (left and right) | 2 | Loosen. |
| 2 | Front wheel sensor | 1 | |
| 3 | Wheel axle pinch bolt | 1 | |
| 4 | Front wheel axle | 1 | |
| 5 | Collar (right) | 1 | |
| 6 | Sensor housing | 1 | |
| 7 | Brake disc (left and right) | 2 | |
| 8 | Front wheel | 1 | |
| | | | For installation, reverse the removal procedure. |

Maintenance of the front wheel sensor and sensor rotor

- ABS wheel sensor and sensor rotor

CAUTION:

- Handle the ABS components with care since they have been accurately adjusted. Keep them away from dirt and do not subject them to shocks.
- The ABS wheel sensor cannot be disassembled. Do not attempt to disassemble it. If faulty, replace with a new one.

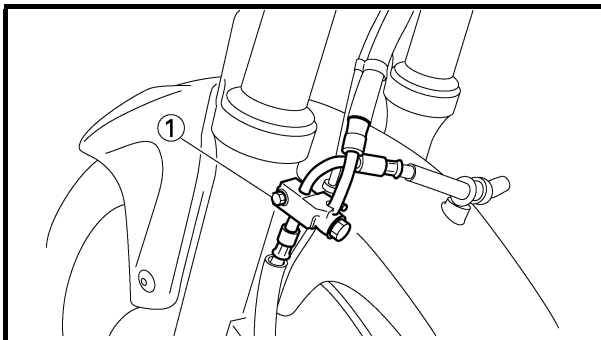

• **Removing the front wheel sensor**

1. Remove:
 - brake hose holder ①
 - front wheel sensor lead holder ②
 - brake caliper ③
 - front wheel sensor ④

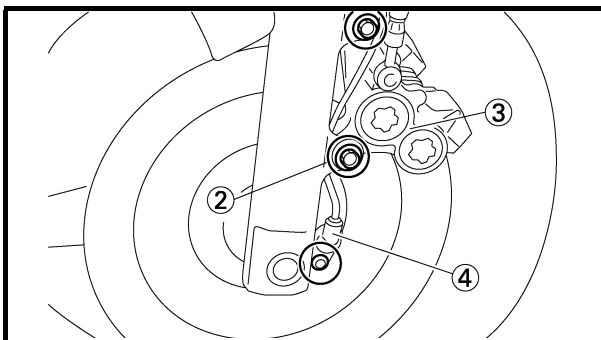

CAUTION:

- Be sure not to contact the sensor electrode to any metal part when removing the front wheel sensor from the sensor housing.
- Do not operate the brake lever when removing the brake caliper.

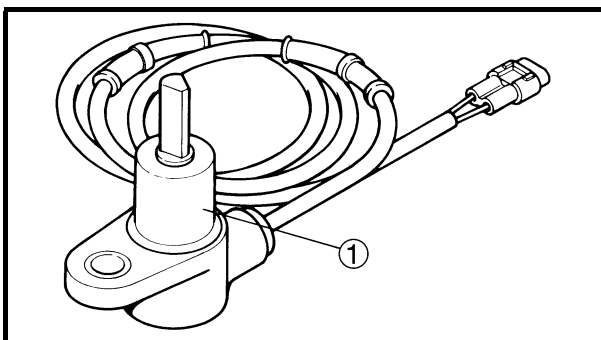

• **Checking the front wheel sensor and sensor rotor**

1. Check:
 - front wheel sensor ①
Cracks/bends/distortion → Replace.
Iron powder/dust → Clean.

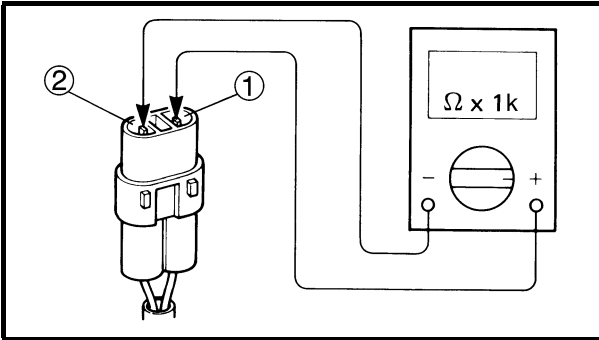

2. Measure:

- front wheel sensor resistance
Connect the pocket tester ($\Omega \times 1k$) to the terminals of the front wheel sensor coupler.
Tester positive probe → Terminal ①
Tester negative probe → Terminal ②



Regulated resistance
1.2 ~ 1.6 k Ω at 20 °C

Out of specification → Replace.

3. Check:

- front wheel sensor rotor ①
Cracks/damage → Replace the front wheel assembly.

NOTE: _____

The wheel sensor rotor of the motorcycle is inserted under pressure by a special process and cannot be replaced as a single unit. To replace the sensor rotor, replace the wheel assembly.

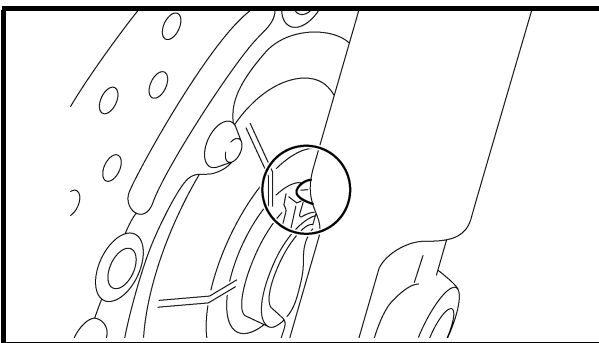
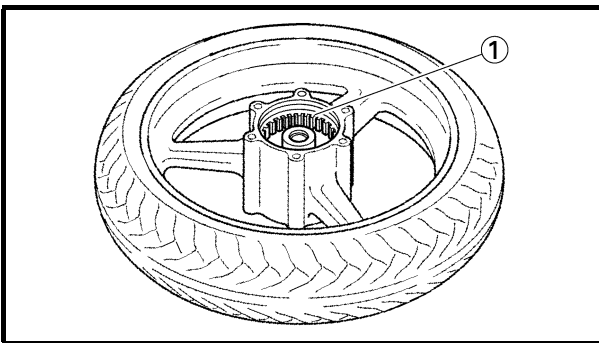

• **Installing the front wheel sensor**

1. Install:

- front wheel

NOTE: _____

Align the slot in the sensor housing with the projection of the front fork before assembly.

CAUTION: _____

Make sure there are no foreign materials in the wheel hub. Foreign materials cause damage to the inner sensor rotor and front wheel sensor.

ANTI-LOCK BRAKE SYSTEM (ABS)

CHAS

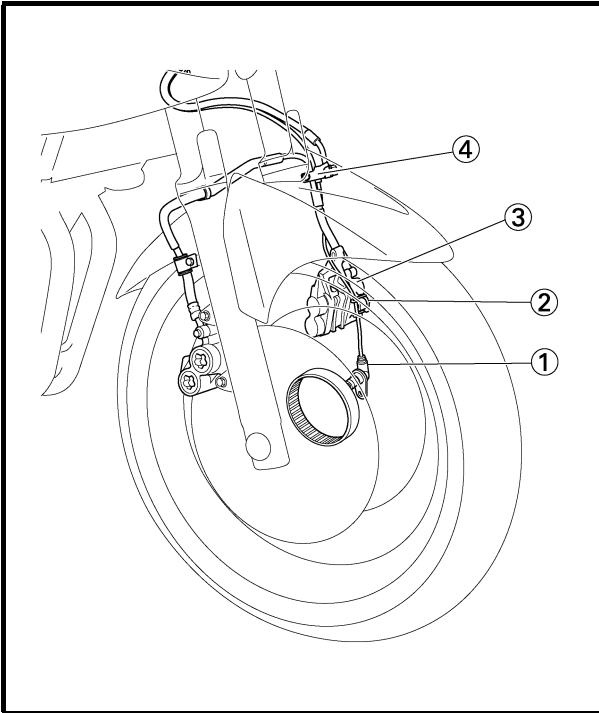

2. Install:

- front wheel sensor ①

 30 Nm (3.0 m•kg, 22 ft•lb)

- front wheel sensor lead holder ②

- brake caliper ③

 40 Nm (4.0 m•kg, 29 ft•lb)

- brake hose holder ④

NOTE:

When installing the front wheel sensor, check the wheel sensor lead for twists and the sensor electrode for foreign materials.

CAUTION:

To route the front wheel sensor lead, refer to “CABLE ROUTING”.

3. Check:

- front wheel sensor installation

Check if the wheel sensor housing is installed properly. Refer to “P51 Maintenance of the front wheel sensor and sensor rotor”.

EAS00890

REAR WHEEL SENSOR AND SENSOR ROTOR

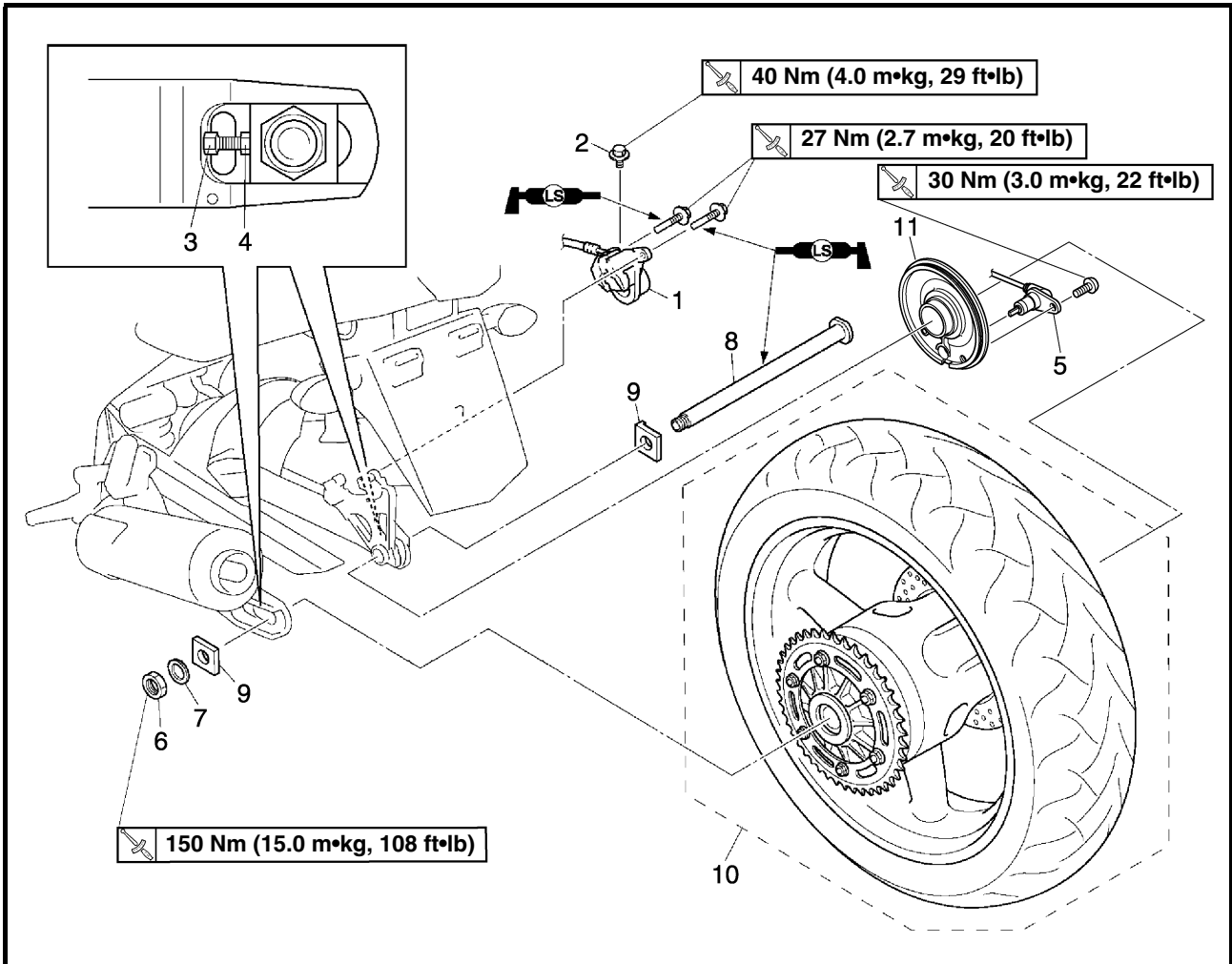

| Order | Job/Part | Q'ty | Remarks |
|-------|--|------|---|
| | Removing the rear wheel sensor and sensor rotor | | Remove the parts in the order listed. NOTE: _____ Place the motorcycle on a suitable stand so that the rear wheel is elevated. |
| 1 | Brake caliper | 1 | |
| 2 | Brake caliper bracket bolt | 1 | |
| 3 | Lock nut | 2 | |
| 4 | Adjusting bolt | 2 | |
| 5 | Rear wheel sensor | 1 | |
| 6 | Wheel axle nut | 1 | |
| 7 | Washer | 2 | |
| 8 | Wheel axle | 1 | |
| 9 | Adjusting block | 2 | |
| 10 | Rear wheel | 1 | |
| 11 | Sensor housing | 1 | |
| | | | For installation, reverse the removal procedure. |

Maintenance of the rear wheel sensor and sensor rotor

CAUTION:

- Be sure not to contact the sensor electrode to any metal part when removing the front wheel sensor from the sensor housing.
- Do not operate the brake lever when removing the brake caliper.

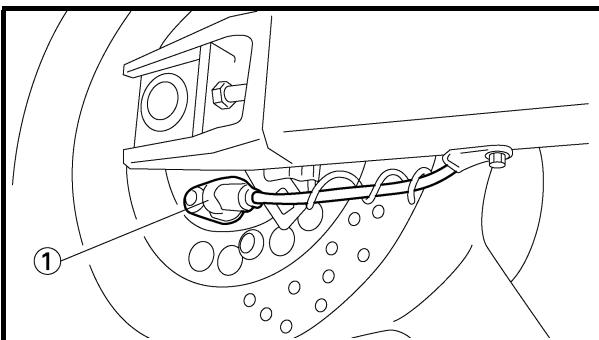
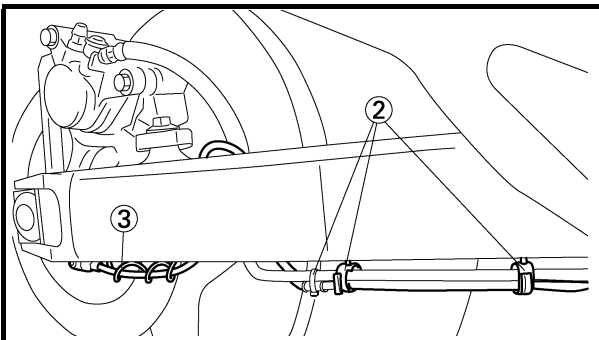
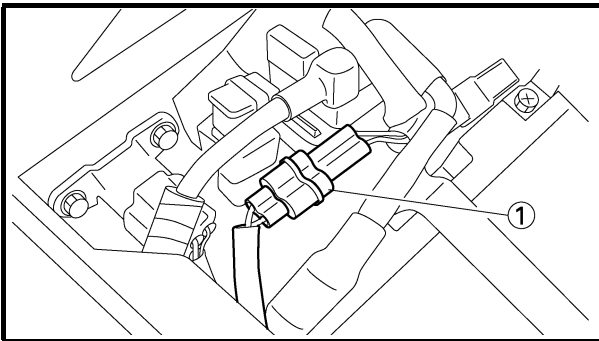

• **Removing the rear wheel sensor**

1. Disconnect:
 - rear wheel sensor ①
2. Remove:
 - clamp ②
 - rear wheel sensor lead holder ③

3. Remove:
 - rear wheel sensor ①

CAUTION:

Be sure not to contact the sensor electrode to any metal part when removing the rear wheel sensor from the sensor housing.

• **Checking the rear wheel sensor and sensor rotor**

Refer to “Checking the front wheel sensor and sensor rotor”.

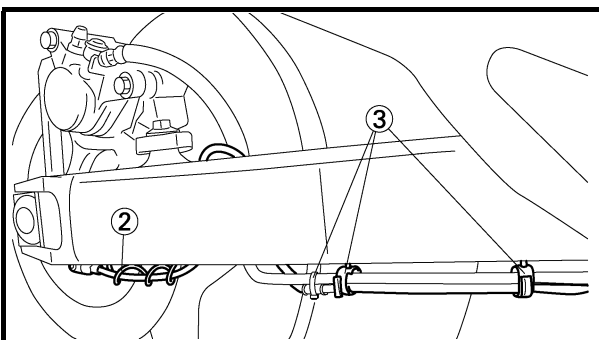
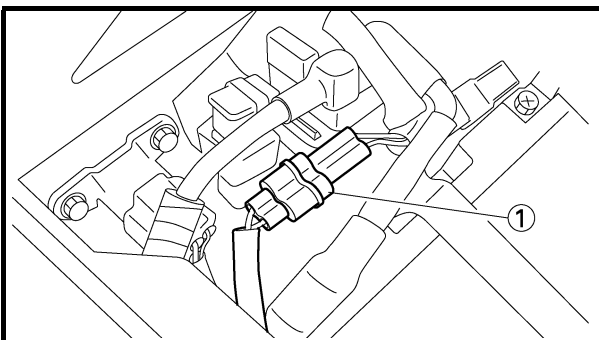
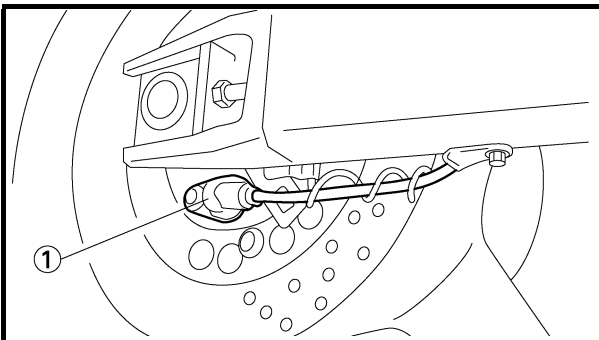
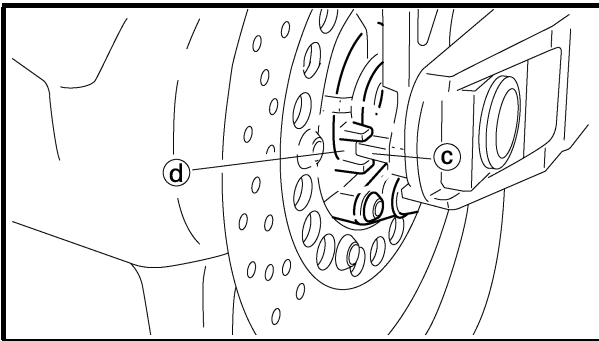
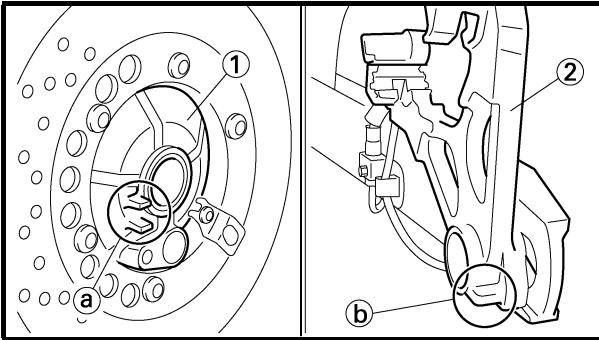

• Installing the rear wheel sensor

1. Install:
 - rear wheel

NOTE:

- Align the slot (a) of the sensor housing (1) with the projection (b) of the rear brake caliper bracket (2), and then assemble them.
- After installation, check that the projection (c) of the rear brake caliper bracket is inserted into the projection (d) of the sensor housing.

CAUTION:

Make sure there are no foreign materials in the wheel hub. Foreign materials cause damage to the inner sensor rotor and rear wheel sensor.

2. Install:

- rear wheel sensor (1)

30 Nm (3.0 m•kg, 22 ft•lb)

NOTE:

When installing the rear wheel sensor, check the rear wheel sensor lead for twists and the sensor electrode for foreign materials.

CAUTION:

To route the rear wheel sensor lead, refer to “CABLE ROUTING”.

3. Connect:

- rear wheel sensor coupler (1)
- rear wheel sensor lead holder (2)
- clamp (3)

CAUTION:

To route the rear wheel sensor lead, refer to “CABLE ROUTING”.

4. Check:

- rear wheel sensor installation
- Check if the wheel sensor housing is installed properly. Refer to “P55 Maintenance of the rear wheel sensor and sensor rotor”.

EAS00891

HYDRAULIC UNIT

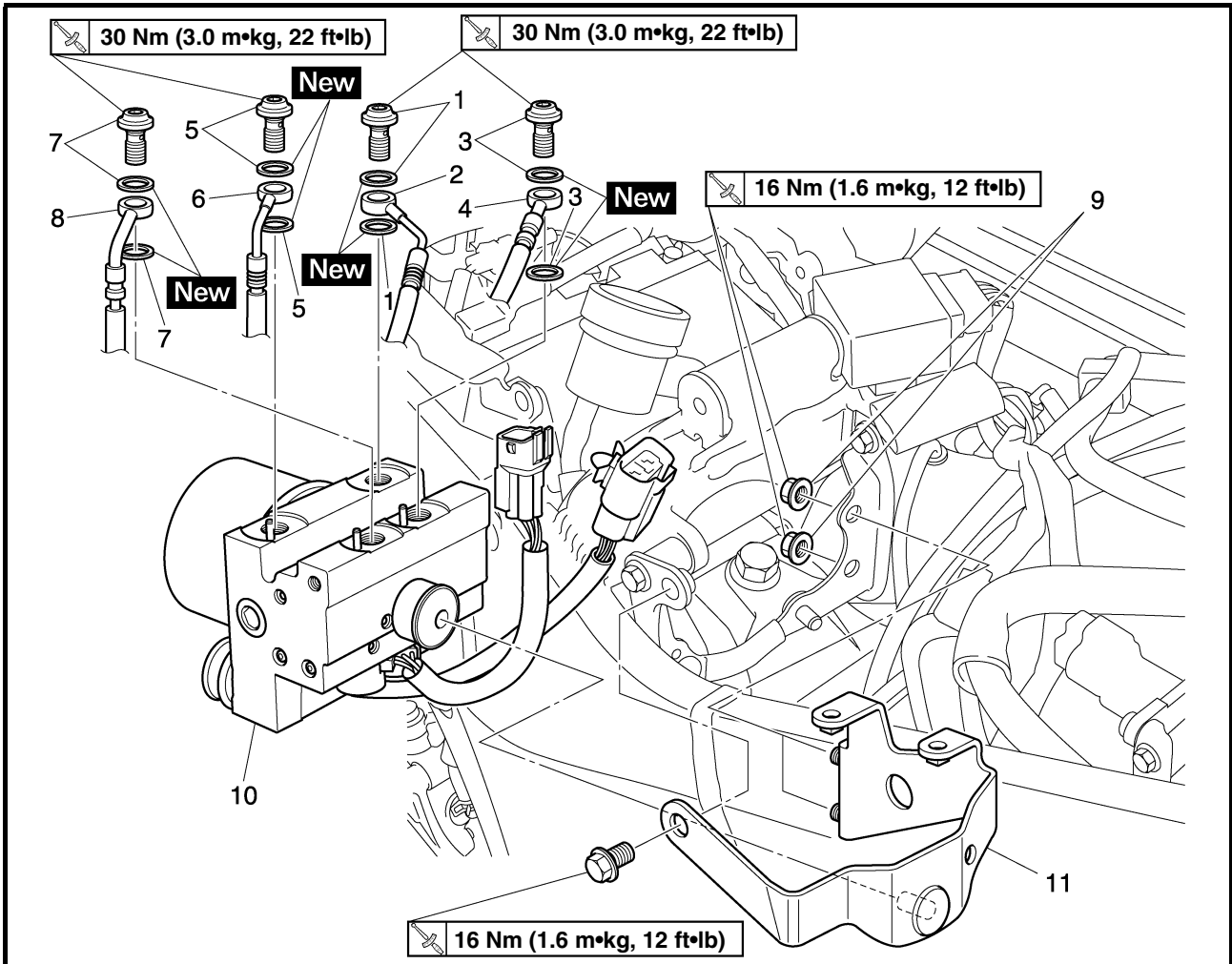

| Order | Job/Part | Q'ty | Remarks |
|-------|---|------|--|
| | Removing the hydraulic unit | | Remove the parts in the order listed. |
| | Seat | | Refer to "SEAT" in chapter 3. (Manual No.: 5PS1-AE1) |
| | Fuel tank | | Refer to "FUEL TANK" in chapter 3. (Manual No.: 5PS1-AE1) |
| | ABS motor coupler/Hydraulic unit solenoid coupler | 1/1 | Refer to "ECU (ABS) AND FAIL-SAFE RELAY". |
| | Fail-safe relay/Fail-safe relay coupler | 1/1 | |
| | Brake fluid | | Drain. |
| 1 | Union bolt/copper washers | 1/2 | |
| 2 | Front brake hose | 1 | (front brake master cylinder to hydraulic unit) |
| 3 | Union bolt/copper washers | 1/2 | |
| 4 | Front brake hose | 1 | (hydraulic unit to front brake caliper) |
| 5 | Union bolt/copper washers | 1/2 | |

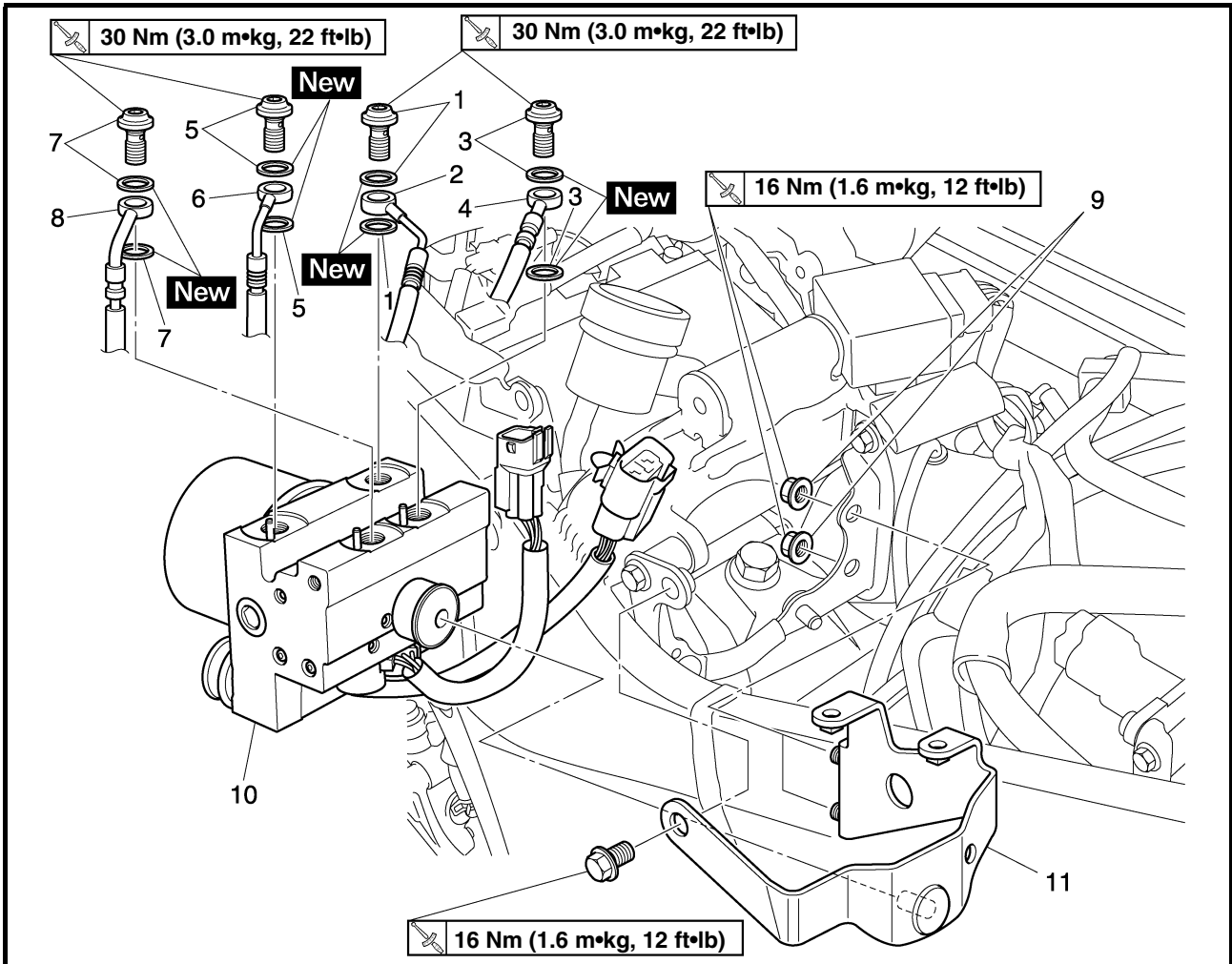

| Order | Job/Part | Q'ty | Remarks |
|-------|---------------------------|------|--|
| 6 | Rear brake hose | 1 | (rear brake master cylinder to hydraulic unit) |
| 7 | Union bolt/copper washers | 1/2 | |
| 8 | Rear brake hose | 1 | (hydraulic unit to rear brake caliper) |
| 9 | Nut | 2 | |
| 10 | Hydraulic unit | 1 | |
| 11 | Hydraulic unit bracket 2 | 1 | |
| | | | For assembly, reverse the disassembly procedure. |

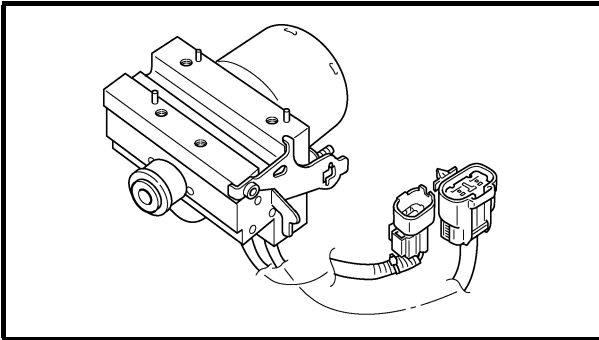

Maintenance of the hydraulic unit

CAUTION:

Do not remove the hydraulic unit to check the resistance of the solenoid valves and the ABS motor for continuity.

⚠ WARNING

Refill with the same type of brake fluid that is already in the system. Mixing fluids may result in a harmful chemical reaction, leading to poor braking performance.

CAUTION:

- Handle the ABS components with care since they have been accurately adjusted. Keep them away from dirt and do not subject them to shocks.
- The ABS wheel sensor cannot be disassembled. Do not attempt to disassemble it. If faulty, replace with a new one.
- Do not set the main switch to “ON” when removing the hydraulic unit.
- Do not clean with compressed air.
- Do not reuse the brake fluid.
- Brake fluid may damage painted surfaces and plastic parts. Therefore, always clean up any spilt brake fluid immediately.
- Do not allow any brake fluid to contact the couplers. Brake fluid may damage the couplers and cause bad contacts.
- If the union bolts for the hydraulic unit have been removed, be sure to tighten them to the specified torque and bleed the brake system.

- Checking the resistance of the solenoid valves and ABS motor for continuity

CAUTION:

When check the hydraulic unit solenoid relay and ABS motor, do not remove the brake hoses.

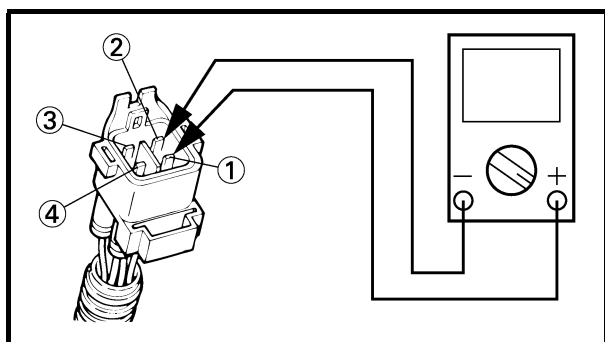

1. Measure:.

- resistance of the solenoid valve (front)
Connect a pocket tester ($\Omega \times 1$) to the terminals of the solenoid valve (front).

Tester positive probe → Terminal ①
Tester negative probe → Terminal ②

| | |
|---|---|
|  | Solenoid valve resistance 2.96 ~ 3.20 Ω at 20 °C |
|---|---|

Out of specification → Replace the hydraulic unit.

2. Measure:

- resistance of the solenoid valve (rear)
Connect the pocket tester ($\Omega \times 1$) to the terminals of solenoid valve (rear).

Tester positive probe → Terminal ④
Tester negative probe → Terminal ③

| | |
|---|---|
|  | Solenoid valve resistance 2.96 ~ 3.20 Ω at 20 °C |
|---|---|

Out of specification → Replace the hydraulic unit.

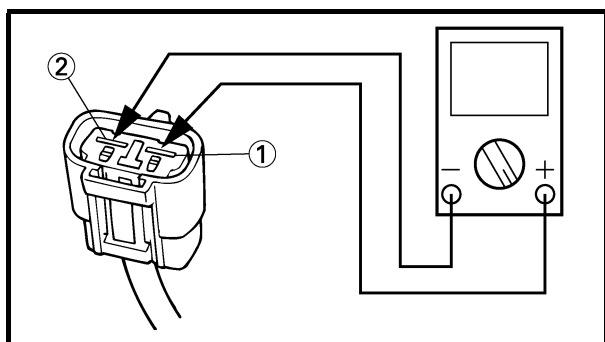

3. Check:

- ABS motor for continuity
Connect the pocket tester ($\Omega \times 1$) to the terminals of the ABS motor coupler.

Tester positive probe → Terminal ①
Tester negative probe → Terminal ②

| | |
|---|-----------------------------|
|  | There is continuity. |
|---|-----------------------------|

No continuity → Replace the hydraulic unit.

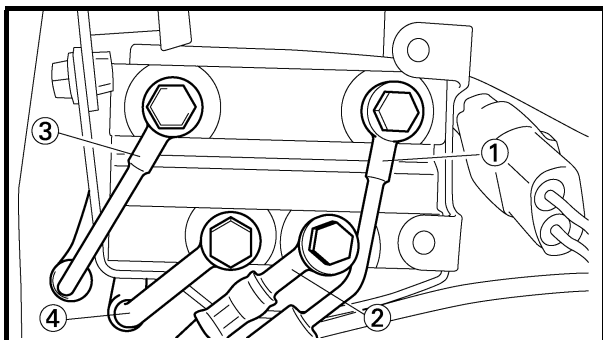

• **Removing the hydraulic unit**

1. Remove:
 - brake hose ① (from the front brake master cylinder)
 - brake hose ② (to the front brake caliper)
 - brake hose ③ (from the rear brake master cylinder)
 - brake hose ④ (to the rear brake caliper)

NOTE: _____
Do not operate the brake lever and brake pedal while removing the brake hoses.

CAUTION: _____

When removing the brake hoses, cover the area around the hydraulic unit to catch any spilt brake fluid. Do not allow the brake fluid to contact other parts.

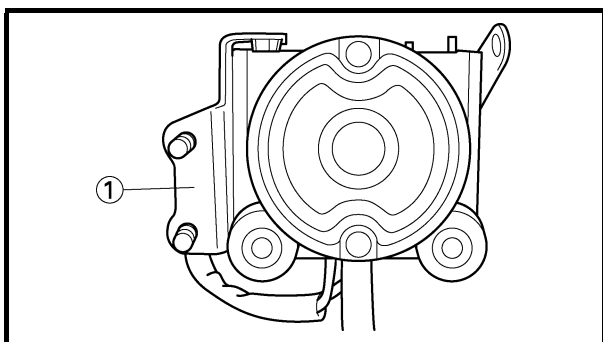

2. Remove:
 - hydraulic unit bracket 2 ①

NOTE: _____
Loosen the nuts in the proper sequence.

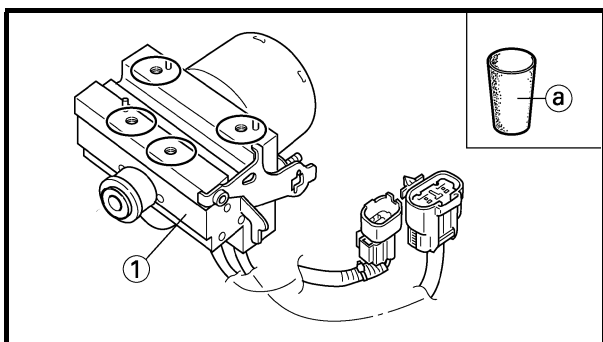

3. Remove:
 - hydraulic unit ①

NOTE: _____
To avoid brake fluid leakage and to prevent foreign materials from entering the hydraulic unit, insert a rubber plug ① or a bolt (M10 × 1.25) into each union bolt hole.

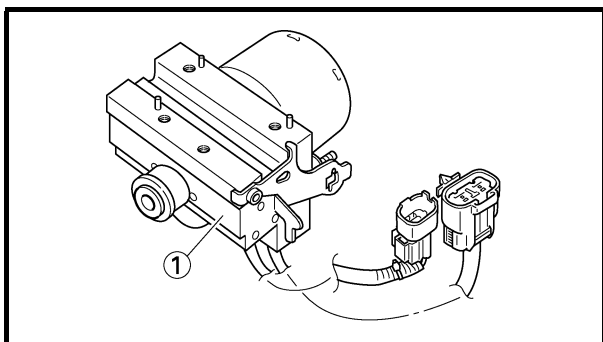

• **Checking the hydraulic unit**

1. Check:
 - hydraulic unit ①
Cracks/damage → Replace the hydraulic unit.

ANTI-LOCK BRAKE SYSTEM (ABS)

CHAS

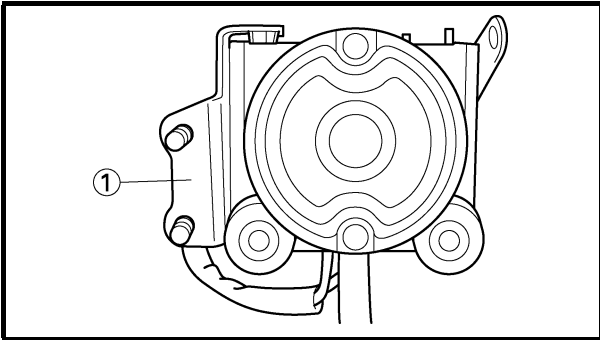

• Installing the hydraulic unit

Proceed in the reverse order of disassembly. Pay attention to the following items.

1. Install:

- hydraulic unit bracket 2 ①

16 Nm (1.6 m•kg, 12 ft•lb)

NOTE:

Tighten the nuts in the proper sequence.

2. Install:

- hydraulic unit

NOTE:

Do not allow any foreign materials to enter the hydraulic unit or the brake hoses when installing the hydraulic unit.

CAUTION:

Do not remove the rubber plugs or bolts (M10 × 1.25) installed in the union bolt holes before installing the hydraulic unit.

3. Remove:

- rubber plugs or bolts (M10 × 1.25)

4. Install:

- copper washer **New**
- brake hose ① (to the rear brake caliper)
- brake hose ② (from the rear brake master cylinder)
- brake hose ③ (to the front brake caliper)
- brake hose ④ (from the front brake master cylinder)
- union bolt

30 Nm (3.0 m•kg, 22 ft•lb)

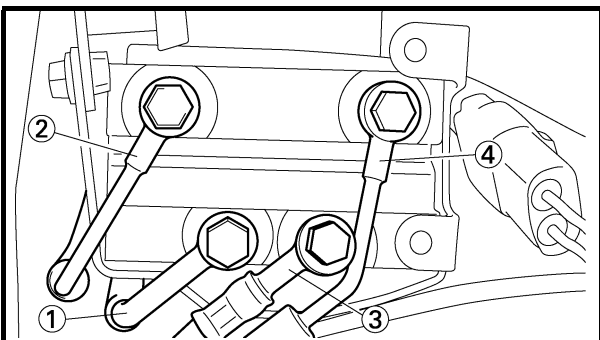

WARNING

The brake hoses to the front and rear brake calipers can be distinguished by the rubber at the end of each hose. Be sure to connect each brake hose to the correct union bolt hole.

CAUTION:

To route the front and rear brake hoses, refer to “CABLE ROUTING”.

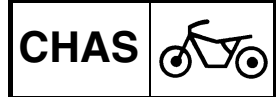

5. Fill:
 - brake master cylinder reservoirs



6. Bleed the brake system.
7. Check the operation of the hydraulic unit according to the brake lever and the brake pedal response. (Refer to "P68 Hydraulic unit operation test 1".)

CAUTION:

Always check the operation of the hydraulic unit according to the brake lever and the brake pedal response.

8. Delete the malfunction codes. (Refer to "P120 Deleting the malfunction codes".)
9. Perform a trial run. (Refer to "P73 Trial run".)

HYDRAULIC ABS

EAS00892

Bleeding the ABS system

⚠ WARNING

Always bleed the brake system when the brake related parts are removed.

CAUTION:

Bleed the brake system in the following order.

1st: Front brake caliper (a)

2nd: Rear brake caliper (b)

- Brake lever ①
- Brake pedal ②
- Front brake hose ③ (from the front brake master cylinder)
- Rear brake hose ④ (from the rear brake master cylinder)

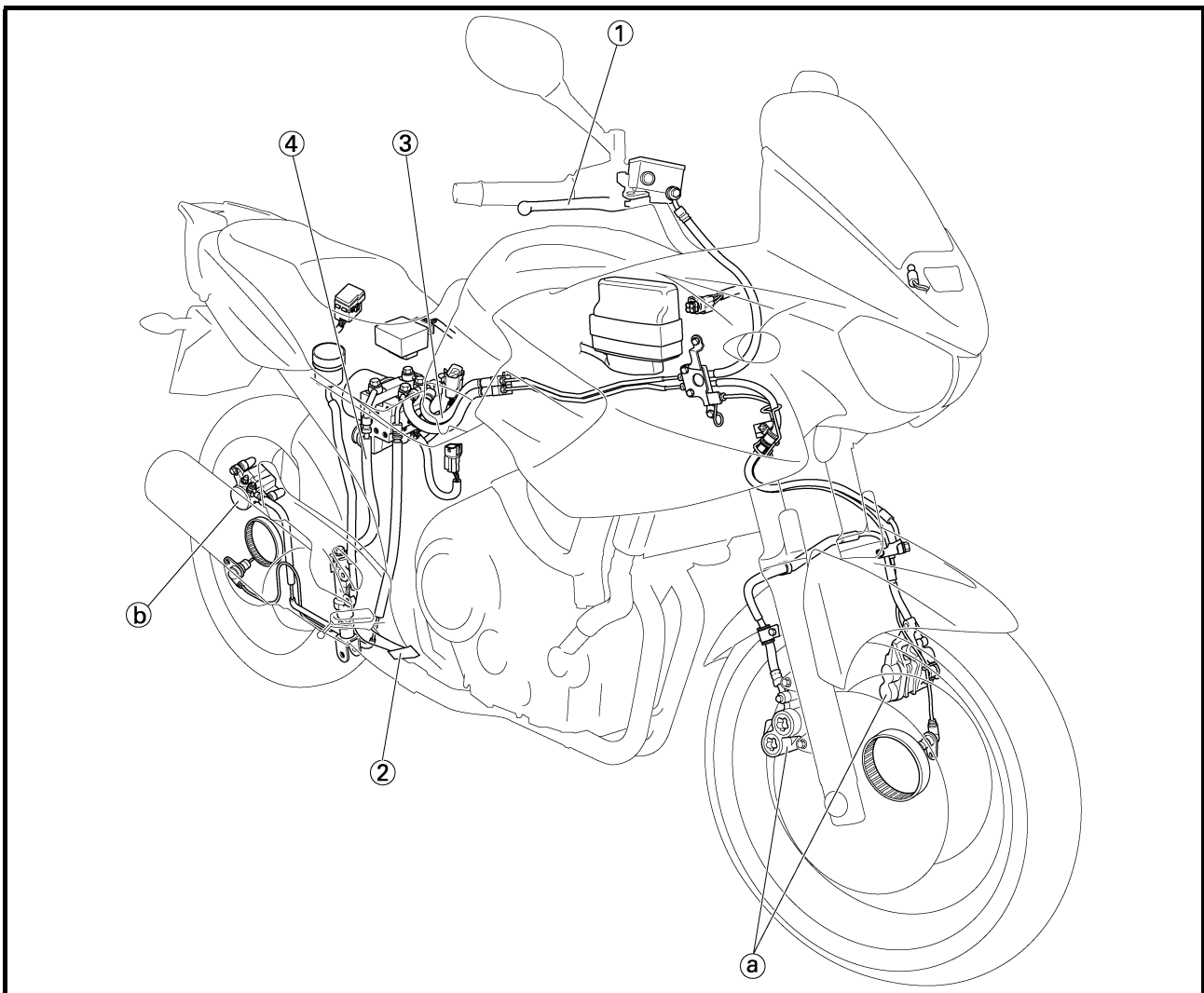

Bleeding instruction

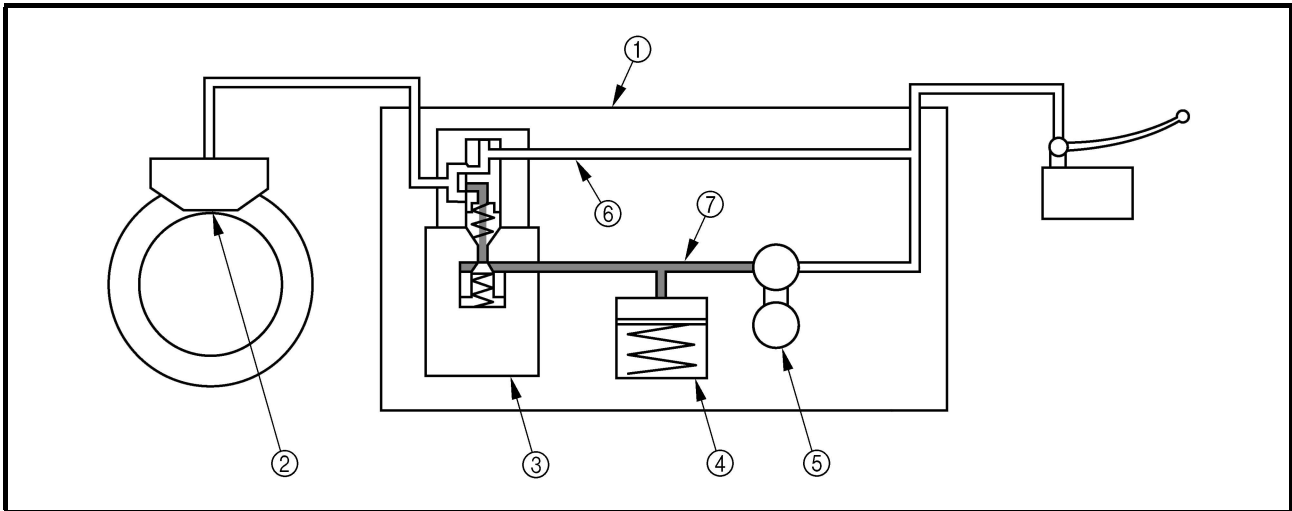

- ① Hydraulic unit
- ② Brake caliper
- ③ Solenoid valve

- ④ Buffer chamber
- ⑤ Hydraulic pump
- ⑥ Brake master cylinder pressure

- ⑦ Hydraulic pump pressure

EAS00134

Bleeding the ABS brake

⚠ WARNING

Bleed the ABS whenever:

- the system is disassembled.
- a brake hose is loosened, disconnected or replaced.
- the brake fluid level is very low.
- brake operation is faulty.

NOTE:

- Be careful not to spill any brake fluid or allow the brake master cylinder reservoir or brake fluid reservoir to overflow.
- When bleeding the ABS, make sure there is always enough brake fluid before applying the brake. Ignoring this precaution could allow air to enter the ABS, considerably lengthening the bleeding procedure.
- If bleeding is difficult, it may be necessary to let the brake fluid settle for a few hours.
- Repeat the bleeding procedure when the tiny bubbles in the hose have disappeared.

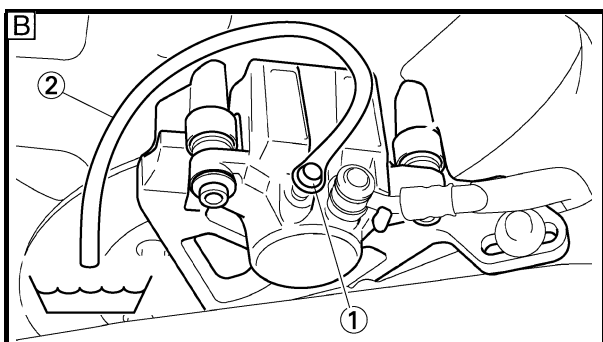
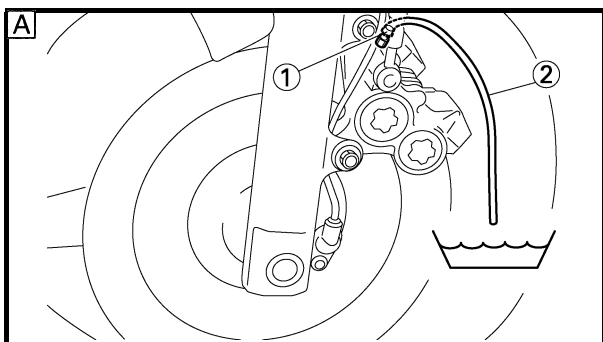

1. Remove:
 - seat
Refer to “SEAT” in chapter 3.
(Manual No.: 5PS1-AE1)

2. Bleed:
 - ABS



- a. Fill the brake fluid reservoir to the proper level with the recommended brake fluid.
- b. Install the diaphragm (brake master cylinder reservoir or brake fluid reservoir).
- c. Connect a clear plastic hose (2) tightly to the bleed screw (1).

- A Front
- B Rear

- d. Place the other end of the hose into a container.
- e. Slowly apply the brake several times.
- f. Fully squeeze the brake lever or fully depress the brake pedal and hold it in position.
- g. Loosen the bleed screw.

NOTE: _____

Loosening the bleed screw will release the pressure and cause the brake lever to contact the throttle grip or the brake pedal to fully extend.

- h. Tighten the bleed screw, and then release the brake lever or brake pedal.
- i. Repeat steps (e) to (h) until all of the air bubbles have disappeared from the brake fluid in the plastic hose.
- j. Check the operation of the hydraulic unit. Refer to “P68 Hydraulic unit operation test 1”.

CAUTION: _____

Make sure that the main switch is set to “OFF” before checking the operation of the hydraulic unit.

- k. After operating the ABS, repeat steps (e) to (i), and then fill the primary circuit with the recommended brake fluid.

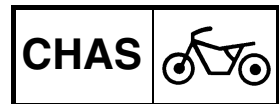

- l. Tighten the bleed screw to the specified torque.

| | |
|---|---|
|  | Bleed screw 6 Nm (0.6 m•kg, 4.3 ft•lb) |
|---|---|

- m. Fill the brake fluid reservoir to the proper level with the recommended brake fluid. Refer to “CHECKING THE BRAKE FLUID LEVEL” in chapter 3. (Manual No.: 5PS1-AE1)

⚠ WARNING

After bleeding the ABS, check the brake operation.



• **Final check**

Checking procedures

1. Check the brake fluid level in the brake master cylinder reservoirs.
2. Check the wheel sensors for proper installation.
3. Perform hydraulic unit operation test 1 or 2.
4. Delete the malfunction codes.
5. Perform a trial run.

• **Checking the brake fluid level of the brake master cylinder reservoirs**

1. Check:
 - brake fluid level
Refer to “CHECKING THE BRAKE FLUID LEVEL” in chapter 3. (Manual No.: 5PS1-AE1)

• **Checking the wheel sensors for proper installation**

1. Check if the front wheel sensor housing and the rear wheel sensor housing are installed correctly. (Refer to “P51 Maintenance of the front wheel sensor and sensor rotor” and “P55 Maintenance of the rear wheel sensor and sensor rotor”.)

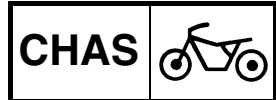

2. Check:

- installation of the wheel sensors to the sensor housings (Refer to “P51 Maintenance of the front wheel sensor and sensor rotor” and “P55 Maintenance of the rear wheel sensor and sensor rotor”.)

| | |
|--|--|
| | Wheel sensor 30 Nm (3.0 m•kg, 22 ft•lb) |
|--|--|

Hydraulic unit operation test

The reaction-force pulsating action generated in the brake lever and brake pedal when the ABS is activated can be tested when the motorcycle is stopped.

The hydraulic unit operation can be tested by the following two methods.

- Hydraulic unit operation test 1: this test generates the same reaction-force pulsating action that is generated in the brake lever and brake pedal when the ABS is activated.
- Hydraulic unit operation test 2: this test checks the function of the ABS after the system was disassembled, adjusted, or serviced.

• Hydraulic unit operation test 1



Securely support the motorcycle so that there is no danger of it falling over.

1. Place the motorcycle on the sidestand.
2. Set the main switch to “OFF”.
3. Remove:
 - seat
Refer to “SEAT”.
(Manual No.: 5PS1-AE1)
 - right side cowling
Refer to “FRONT COWLINGS”.
(Manual No.: 5PS1-AE1)

ANTI-LOCK BRAKE SYSTEM (ABS)

CHAS

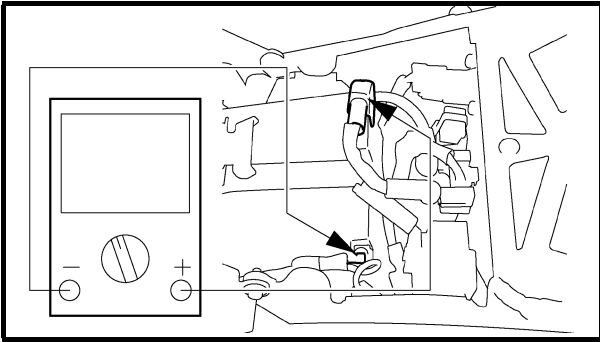

4. Check:
- battery voltage



Battery voltage
Higher than 12.8 V

Lower than 12.8 V → Charge or replace the battery.

NOTE:

- If the battery voltage is lower than 12.8 V, charge the battery and perform hydraulic unit operation test 1.
- If the battery voltage is lower than 10 V, the ABS warning light comes on and the ABS does not operate.

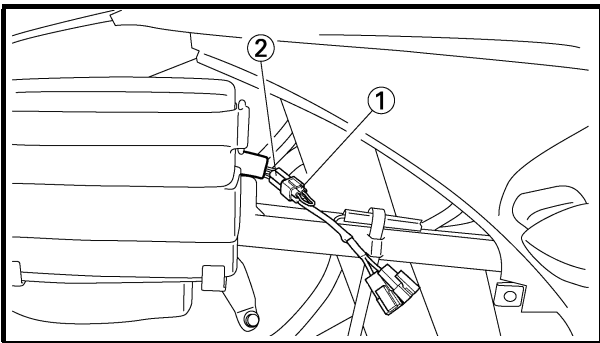

5. Connect the test coupler adaptor (1) to the test coupler (2).



Test coupler adaptor
90890-03149

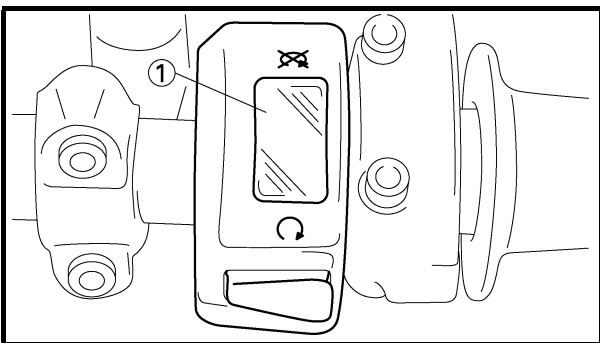

6. Set the engine stop switch (1) to "OFF".
7. Set the main switch to "ON".

NOTE:

After setting the main switch to "ON", wait (approximately 2 seconds) until the ABS warning light goes off.

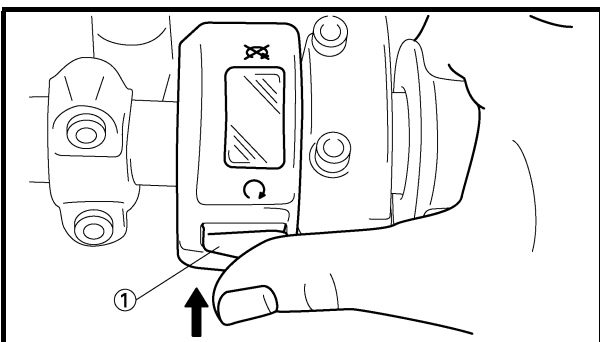

8. Push the start switch (1) for at least 4 seconds.

CAUTION:

Do not operate the brake lever or the brake pedal.

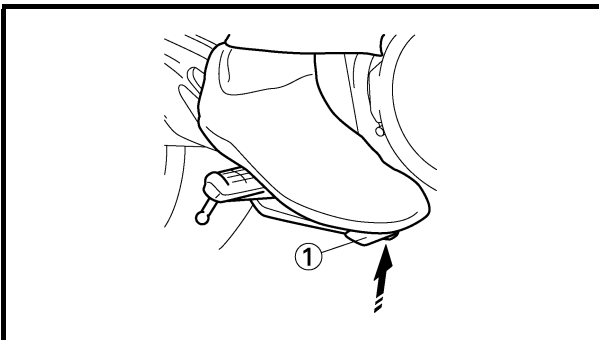
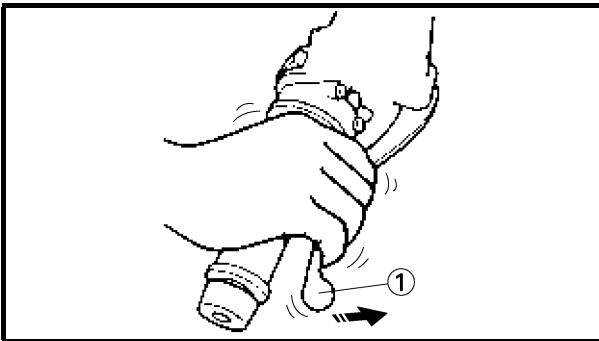
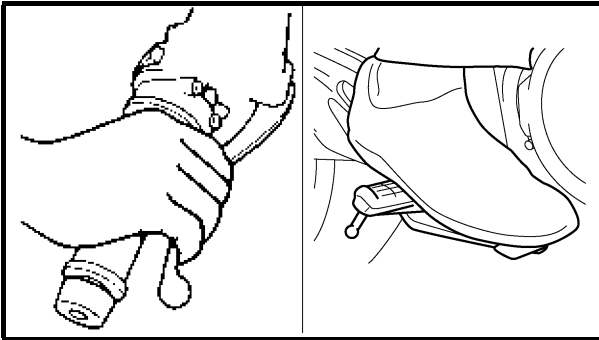

9. After releasing the start switch, operate the brake lever and the brake pedal simultaneously.

NOTE: _____

- A reaction-force pulsating action is generated in the brake lever ① 0.5 second after the brake lever and the brake pedal are operated simultaneously and continues for approximately 1 second.
- Be sure to continue to operate the brake lever and brake pedal even after the pulsating action has stopped.

10. After the pulsating action has stopped in the brake lever, it is generated in the brake pedal ① 0.5 second after and continues for approximately 1 second.

NOTE: _____

Be sure to continue to operate the brake lever and brake pedal even after the pulsating action has stopped.

11. After the pulsating action has stopped in the brake pedal, it is generated in the brake lever 0.5 second after and continues for approximately 1 second.

CAUTION: _____

- Check that the pulsating action is felt in the brake lever, brake pedal, and again in the brake lever, in this order.
- If the pulsating action is felt in the brake pedal before it is felt in the brake lever, check that the brake hoses are connected correctly to the hydraulic unit.
- If the pulsating action is hardly felt in either the brake lever or brake pedal, check that the brake hoses are connected correctly to the hydraulic unit.

12. Set the main switch to "OFF".
13. Remove the test coupler adaptor from the test coupler.
14. Set the main switch to "ON".
15. Set the engine stop switch to "⊙".

• Hydraulic unit operation test 2

⚠ WARNING

Securely support the motorcycle so that there is no danger of it falling over.

1. Place the motorcycle on the centerstand.
2. Set the main switch to "OFF".
3. Remove:
 - seat
Refer to "SEAT".
(Manual No.: 5PS1-AE1)
 - right side cowling
Refer to "FRONT COWLINGS".
(Manual No.: 5PS1-AE1)
4. Check:
 - battery voltage

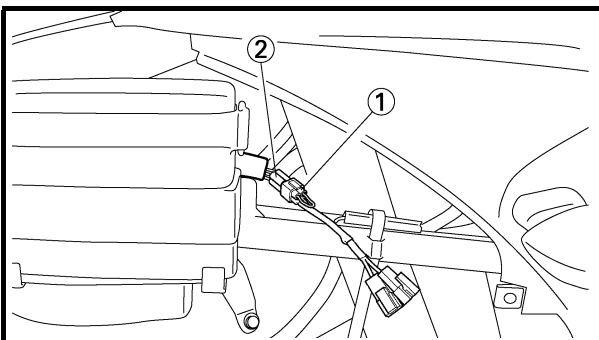
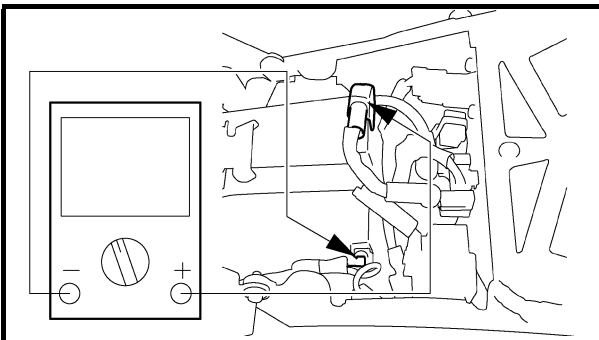

| | |
|---|---|
|  | Battery voltage Higher than 12.8 V |
|---|---|

Lower than 12.8 V → Charge or replace the battery.

NOTE:

- If the battery voltage is lower than 12.8 V, charge the battery and perform hydraulic unit operation test 2.
- If the battery voltage is lower than 10 V, the ABS warning light comes on and the ABS does not operate.

5. Connect the test coupler adaptor ① to the test coupler ②.

| | |
|---|---|
|  | Test coupler adaptor 90890-03149 |
|---|---|

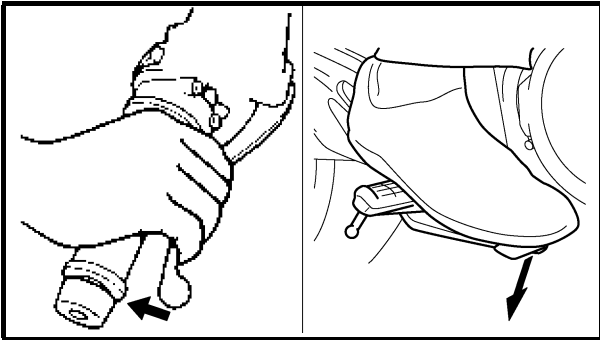

6. Set the main switch to “ON” while operating the brake lever and the brake pedal simultaneously.

CAUTION:

When the main switch is set to “ON”, be sure to operate both the brake levers and the brake pedal simultaneously. If only the brake levers or brake pedal are operated, set the main switch to “OFF” and start the procedure again.

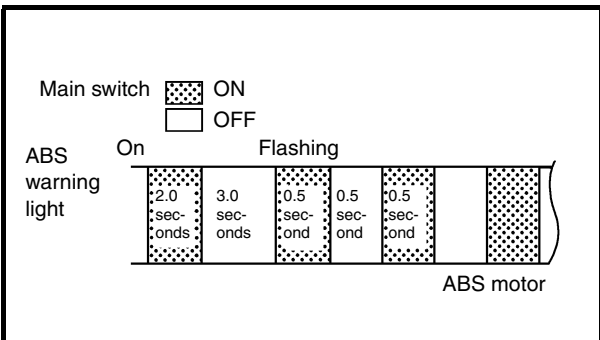

7. Check:

- Hydraulic unit operation

When the main switch is set to “ON”, the ABS warning light comes on for 2 seconds, goes off for 3 seconds, then starts flashing. When the ABS warning light starts flashing, the brake lever ① will return to its home position. The brake pedal ② will then return to its home position, then the brake lever will return to its home position again.

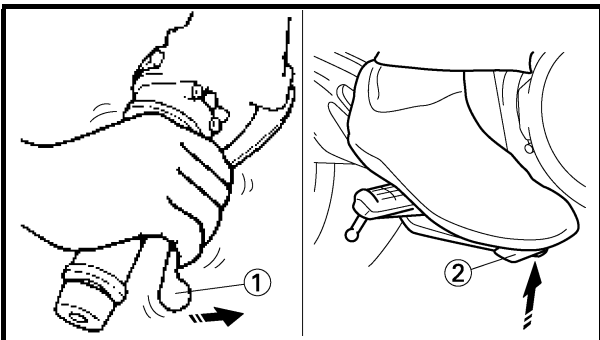

CAUTION:

- Check that the brake lever returns to its home position before the brake pedal returns to its home position.
- If the brake pedal returns to its home position before the brake lever does, check that the brake hoses are connected correctly to the hydraulic unit.
- If either the brake lever or brake pedal returns to its home position slowly, check that the brake hoses are connected correctly to the hydraulic unit.

- If the operation of the hydraulic unit is normal, delete all of the malfunction codes.

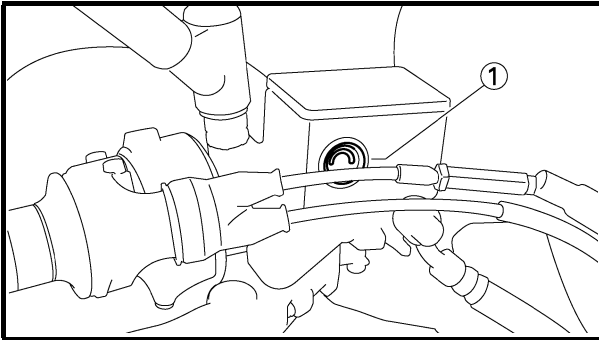

CHECKING THE RESERVOIR TANK FLUID LEVEL

1. Check:

- brake fluid level

Keep the reservoir cap horizontal and check the level.

Less than the low level → Add the brake fluid more than low level ①.



**Recommended brake fluid
DOT #4**

CAUTION:

- Do not mix the brake fluids of different brands.
- If the brake fluid is attached to the coated surface, plastics or rubbers, it may cause the damage. Do not allow it to attach. Wipe off the attached brake fluid immediately.

TRIAL RUN

After all checks and services are completed, always ensure the motorcycle has no problems by performing the trial running at a speed of faster than 10 km/h.

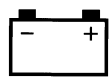

EAS00729

ELECTRICAL

ELECTRICAL COMPONENTS

- ① Wire harness
- ② Ignition coil
- ③ Front brake light switch
- ④ Clutch switch
- ⑤ Fail safe relay
- ⑥ Starter relay
- ⑦ Fuse box
- ⑧ Battery
- ⑨ Neutral switch
- ⑩ Sidestand switch
- ⑪ Rear brake light switch
- ⑫ Oil level switch
- ⑬ Radiator fan motor
- ⑭ ECU (ABS)
- ⑮ Horn

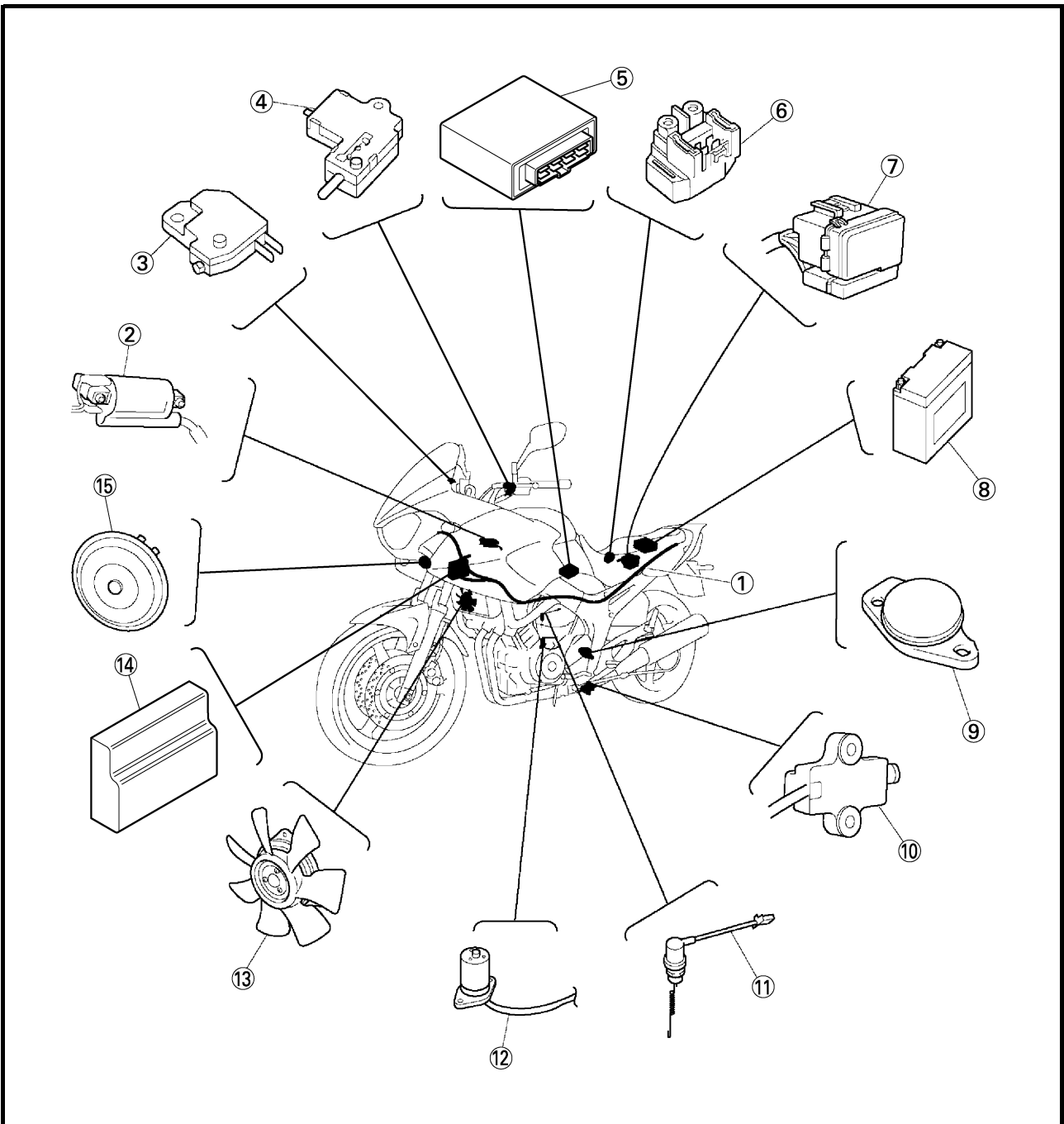

ELECTRICAL COMPONENTS

ELEC

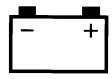

- ① Coolant temperature sensor
- ② Atmospheric pressure sensor
- ③ Intake air temperature sensor
- ④ Intake air pressure sensor
- ⑤ Lean angle cut-off switch
- ⑥ Turn signal relay
- ⑦ Fuel injection system relay
- ⑧ Radiator fan motor relay
- ⑨ Rear wheel sensor
- ⑩ Starting circuit cut-off relay
- ⑪ Speed sensor
- ⑫ O₂ sensor
- ⑬ Crankshaft position sensor
- ⑭ Front wheel sensor
- ⑮ Cylinder identification sensor
- ⑯ ECU

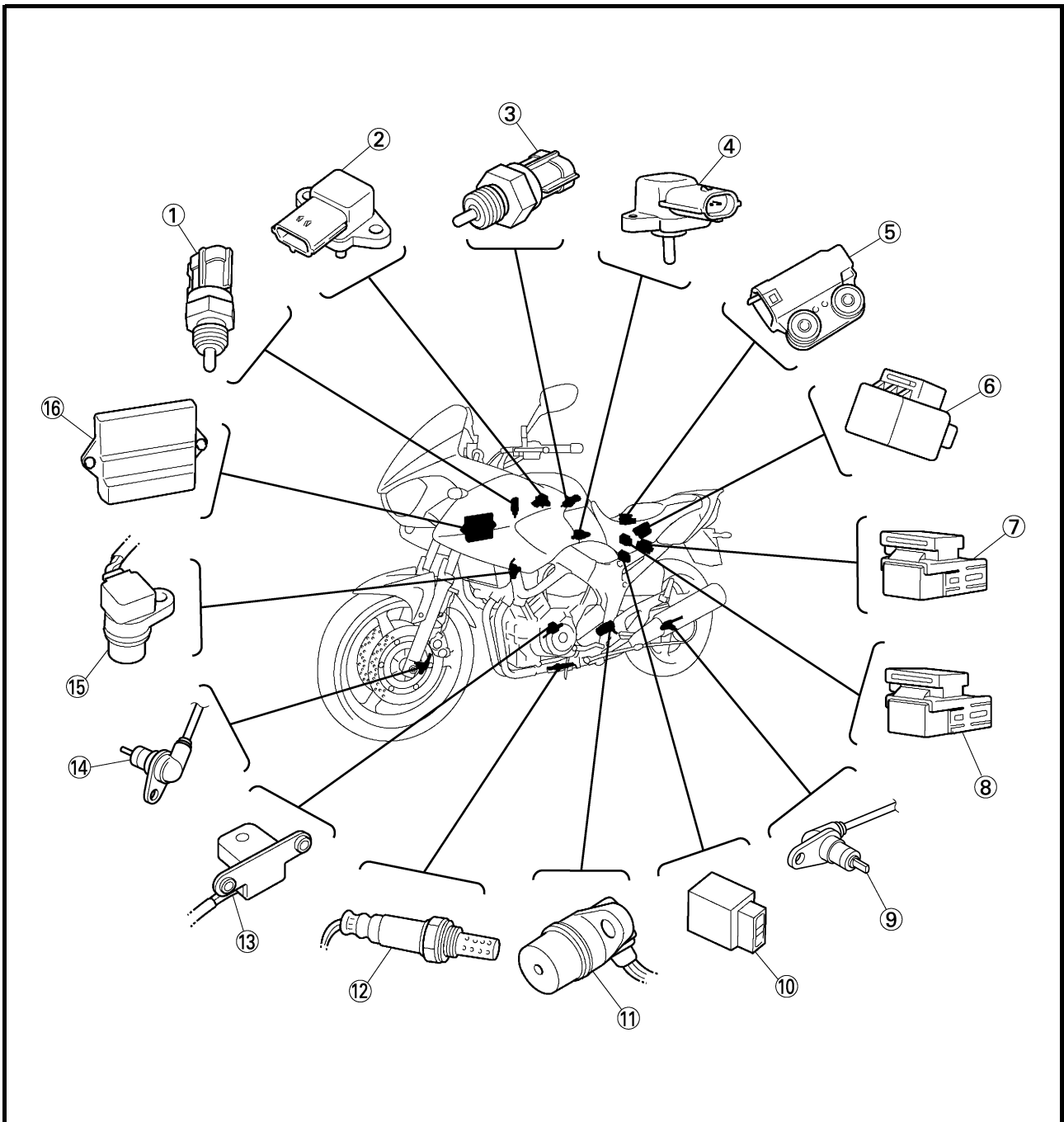

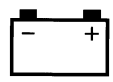

EAS00731

CHECKING THE SWITCHES

Check each switch for damage or wear, proper connections, and also for continuity between the terminals. Refer to "CHECKING SWITCH CONTINUITY".

Damage/wear Repair or replace.

Improperly connected Properly connect.

Incorrect continuity reading Replace the switch.

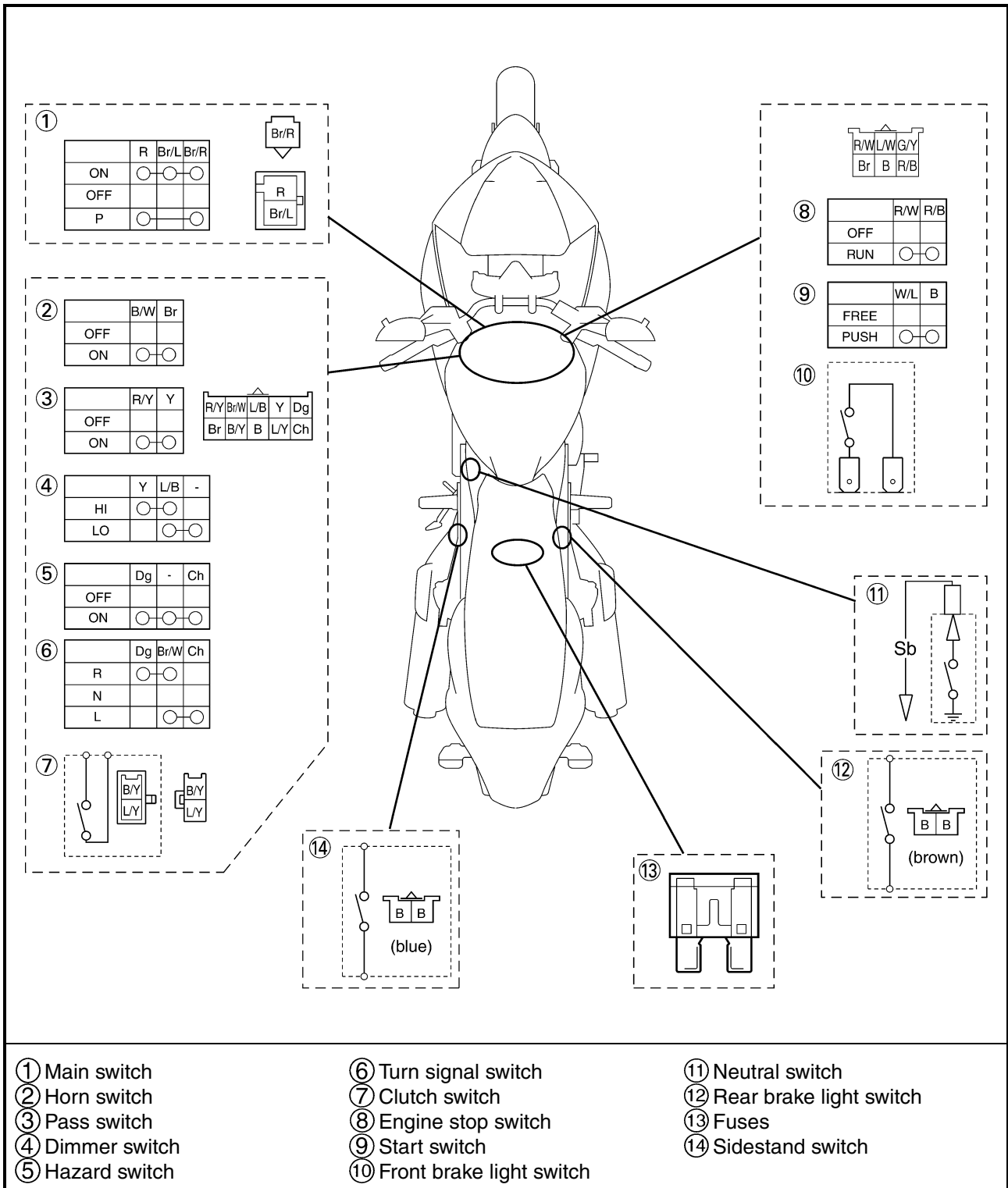

- ① Main switch
- ② Horn switch
- ③ Pass switch
- ④ Dimmer switch
- ⑤ Hazard switch

- ⑥ Turn signal switch
- ⑦ Clutch switch
- ⑧ Engine stop switch
- ⑨ Start switch
- ⑩ Front brake light switch

- ⑪ Neutral switch
- ⑫ Rear brake light switch
- ⑬ Fuses
- ⑭ Sidestand switch

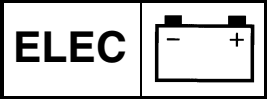

EAS00755

ELECTRIC STARTING SYSTEM CIRCUIT DIAGRAM

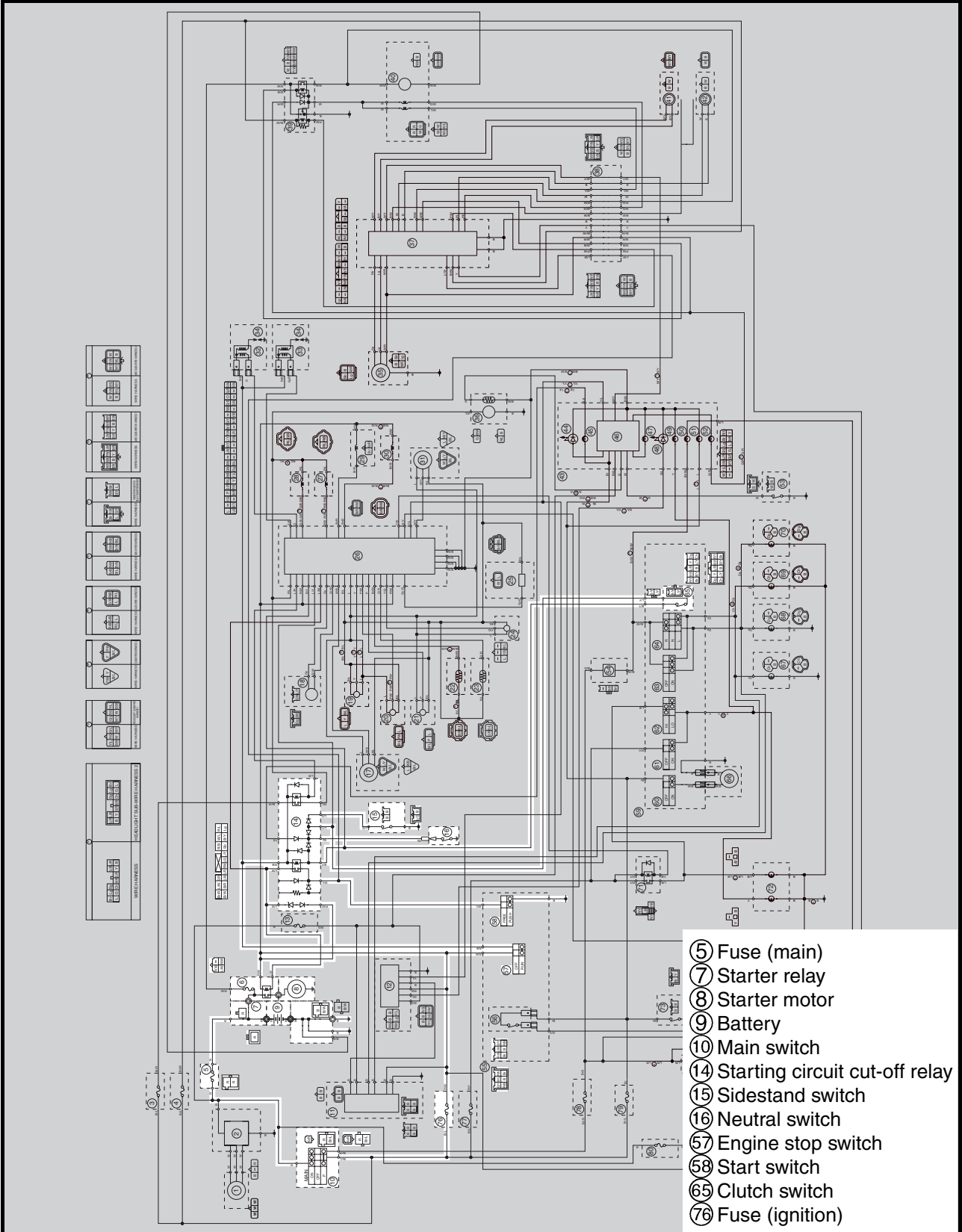

- ⑤ Fuse (main)
- ⑦ Starter relay
- ⑧ Starter motor
- ⑨ Battery
- ⑩ Main switch
- ⑭ Starting circuit cut-off relay
- ⑮ Sidestand switch
- ⑯ Neutral switch
- ⑰ Engine stop switch
- ⑱ Start switch
- ⑲ Clutch switch
- ⑳ Fuse (ignition)

EAS00756

STARTING CIRCUIT CUT-OFF SYSTEM OPERATION

If the engine stop switch is set to “⌚” and the main switch is set to “ON” (both switches are closed), the starter motor can only operate if at least one of the following conditions is met:

- The transmission is in neutral (the neutral switch is closed).
- The clutch lever is pulled to the handlebar (the clutch switch is closed) and the side-stand is up (the sidestand switch is closed).

The starting circuit cut-off relay prevents the starter motor from operating when neither of these conditions has been met. In this instance, the starting circuit cut-off relay is open so current cannot reach the starter motor. When at least one of the above conditions has been met the starting circuit cut-off relay is closed and the engine can be started by pressing the starter switch.

 WHEN THE TRANSMISSION IS IN NEUTRAL

 WHEN THE SIDESTAND IS UP AND THE CLUTCH LEVER IS PULLED TO THE HANDLEBAR

- ① Battery
- ② Main fuse
- ③ Main switch
- ④ Ignition fuse
- ⑤ Engine stop switch
- ⑥ Starting circuit cut-off relay
- ⑦ Diode (starting circuit cut-off relay)
- ⑧ Clutch switch
- ⑨ Sidestand switch
- ⑩ Neutral switch
- ⑪ Start switch
- ⑫ Starter relay
- ⑬ Starter motor

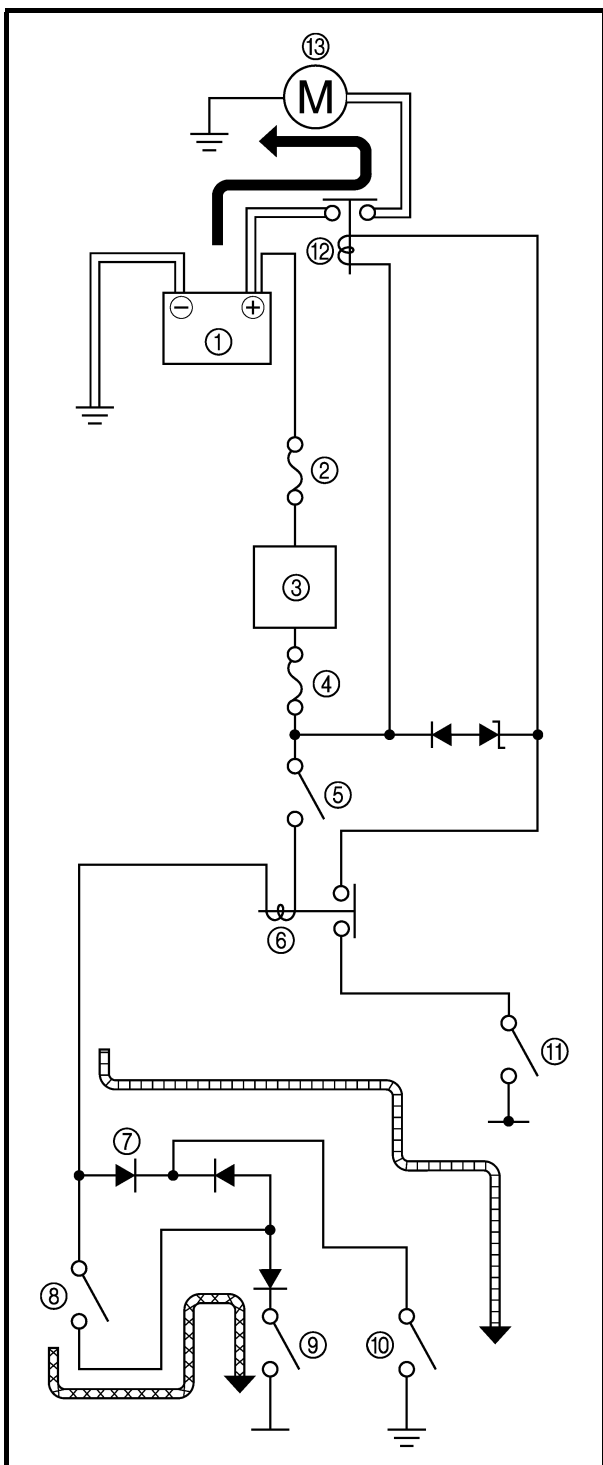

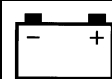

EAS00757

TROUBLESHOOTING

The starter motor fails to turn.

Check:

1. main and ignition fuses
2. battery
3. starter motor
4. starting circuit cut-off relay
5. diode (starting circuit cut-off relay)
6. starter relay
7. main switch
8. engine stop switch
9. neutral switch
10. sidestand switch
11. clutch switch
12. start switch
13. wiring connections
(of the entire starting system)

NOTE:

- Before troubleshooting, remove the following part(s):
 - 1) seat
 - 2) fuel tank
 - 3) air filter case
 - 4) side cowlings
- Troubleshoot with the following special tool(s).



Pocket tester
90890-03132

EAS00738

1. Main and ignition fuses

- Check the main and ignition fuses for continuity. Refer to “CHECKING THE FUSES” in chapter 3. (Manual No.: 5PS1-AE1)
- Are the main and ignition fuses OK?

↓ YES

↓ NO

Replace the fuse(s).

EAS00739

2. Battery

- Check the condition of the battery. Refer to “CHECKING AND CHARGING THE BATTERY” in chapter 3. (Manual No.: 5PS1-AE1)



Minimum open-circuit voltage
12.8 V or more at 20°C

- Is the battery OK?

↓ YES

↓ NO

- Clean the battery terminals.
- Recharge or replace the battery.

EAS00758

3. Starter motor

- Connect the positive battery terminal ① and starter motor lead ② with a jumper lead ③.

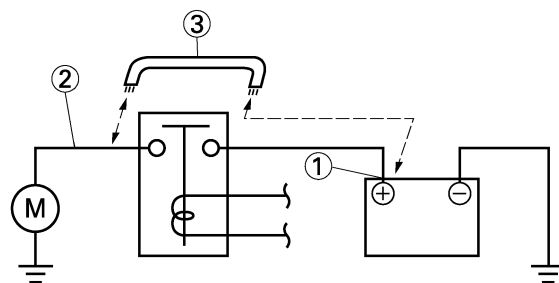

⚠ WARNING

- A wire that is used as a jumper lead must have at least the same capacity or more as that of the battery lead, otherwise the jumper lead may burn.
- This check is likely to produce sparks, therefore make sure nothing flammable is in the vicinity.

- Does the starter motor turn?

↓ YES

↓ NO

Repair or replace the starter motor.

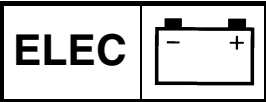

EAS00759

4. Starting circuit cut-off relay

- Disconnect the starting circuit cut-off relay from the wire harness.
- Connect the pocket tester ($\Omega \times 1$) and battery (12 V) to the starting circuit cut-off relay terminals as shown.

Battery positive terminal → red/black ①

Battery negative terminal → black/yellow ②

Tester positive probe → blue/white ③

Tester negative probe → white/blue ④

• Does the starting circuit cut-off relay have continuity between blue/white and black?



Replace the starting circuit cut-off relay.

EAS00760

5. Starting circuit cut-off relay (diode)

- Disconnect the starting circuit cut-off relay from the wire harness.
- Connect the pocket tester ($\Omega \times 1$) to the starting circuit cut-off relay terminals as shown.
- Measure the starting circuit cut-off relay for continuity as follows.

| | |
|---|---------------|
| Tester positive probe → black/yellow ② Tester negative probe → sky blue ① | Continuity |
| Tester positive probe → blue/yellow ③ Tester negative probe → sky blue ① | |
| Tester positive probe → blue/yellow ③ Tester negative probe → blue/green ④ | |
| Tester positive probe → sky blue ① Tester negative probe → black/yellow ② | No continuity |
| Tester positive probe → sky blue ① Tester negative probe → blue/yellow ③ | |
| Tester positive probe → blue/green ④ Tester negative probe → blue/yellow ③ | |

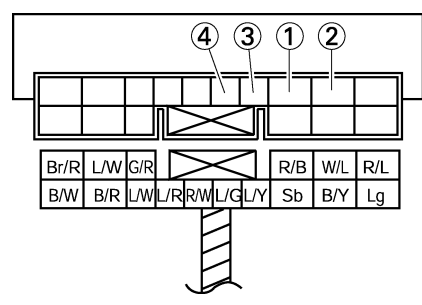

NOTE: When you switch the tester's positive and negative probes, the readings in the above chart will be reversed.

• Are the testing readings correct?



Replace the starting circuit cut-off relay.

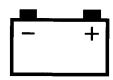

EAS00761

6. Starter relay

- Disconnect the starter relay from the coupler.
- Connect the pocket tester ($\Omega \times 1$) and battery (12 V) to the starter relay terminals as shown.

Battery positive terminal → red/white ①

Battery negative terminal → blue/white ②

Tester positive probe → red ③

Tester negative probe → black ④

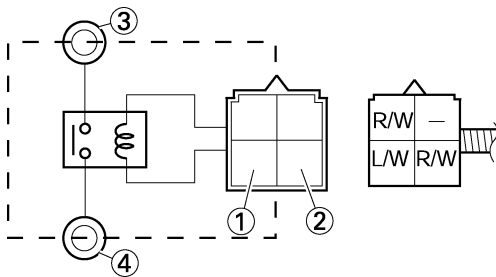

- Does the starter relay have continuity between red and black?

↓ YES

↓ NO

Replace the starter relay.

EAS00749

7. Main switch

- Check the main switch for continuity. Refer to "CHECKING THE SWITCHES".
- Is the main switch OK?

↓ YES

↓ NO

Replace the main switch.

EAS00750

8. Engine stop switch

- Check the engine stop switch for continuity. Refer to "CHECKING THE SWITCHES".
- Is the engine stop switch OK?

↓ YES

↓ NO

Replace the right handlebar switch.

EAS00751

9. Neutral switch

- Check the neutral switch for continuity. Refer to "CHECKING THE SWITCHES".
- Is the neutral switch OK?

↓ YES

↓ NO

Replace the neutral switch.

EAS00752

10. Sidestand switch

- Check the sidestand switch for continuity. Refer to "CHECKING THE SWITCHES".
- Is the sidestand switch OK?

↓ YES

↓ NO

Replace the side-stand switch.

EAS00763

11. Clutch switch

- Check the clutch switch for continuity. Refer to "CHECKING THE SWITCHES".
- Is the clutch switch OK?

↓ YES

↓ NO

Replace the clutch switch.

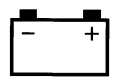

EAS00764

12. Start switch

- Check the start switch for continuity. Refer to “CHECKING THE SWITCHES”.
- Is the start switch OK?

↓ YES

↓ NO

Replace the right handlebar switch.

EAS00766

13. Wiring

- Check the entire starting system’s wiring. Refer to “CIRCUIT DIAGRAM”.
- Is the starting system’s wiring properly connected and without defects?

↓ YES

↓ NO

The starting system circuit is OK.

Properly connect or repair the starting system’s wiring.

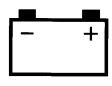

EAS00780

SIGNALING SYSTEM
CIRCUIT DIAGRAM

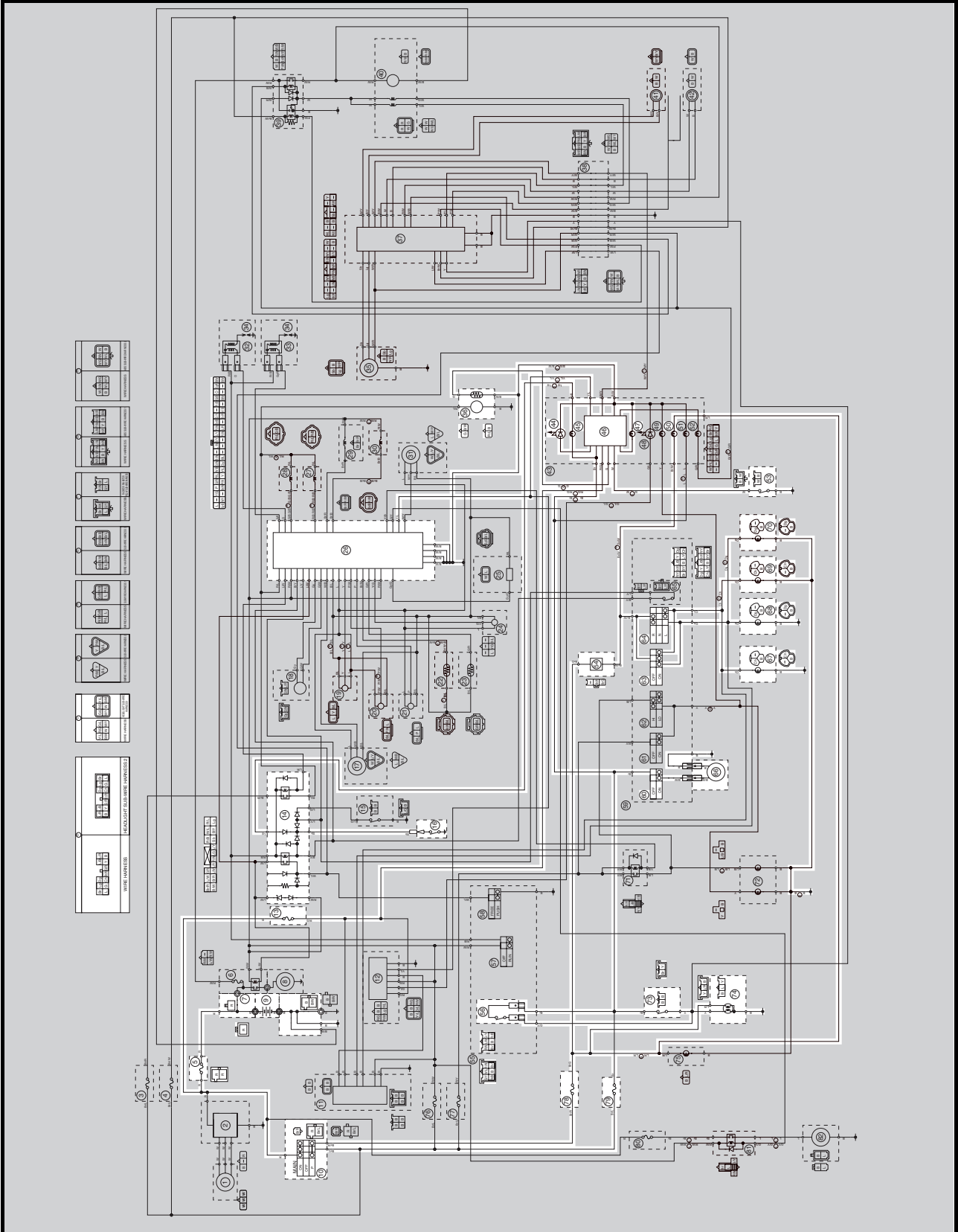

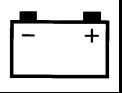

- ⑤ Fuse (main)
- ⑨ Battery
- ⑩ Main switch
- ⑬ Fuse (backup)
- ⑭ Starting circuit cut-off relay
- ⑯ Neutral switch
- ⑳ ECU
- ㉑ Fuel pump
- ㉔ Oil level warning light
- ㉕ Neutral indicator light
- ㉖ Multi-function meter
- ㉗ Engine trouble warning light
- ㉘ Turn signal indicator light
- ㉚ Oil level switch
- ㉛ Turn signal relay
- ㉜ Front brake light switch
- ㉞ Horn switch
- ㉟ Hazard switch
- ㊱ Turn signal switch
- ㊲ Horn
- ㊳ Rear turn signal light (left)
- ㊴ Rear turn signal light (right)
- ㊵ Front turn signal light (left)
- ㊶ Front turn signal light (right)
- ㊸ Rear brake light switch
- ㊹ Tail/brake light
- ㊺ Fuse (hazard)
- ㊻ Fuse (signal)

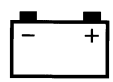

EAS00794

TROUBLESHOOTING

- Any of the following fail to light: turn signal light, brake light or an indicator light.
- The horn fails to sound.

Check:

1. main, signaling, hazard light and back up fuses
2. battery
3. main switch
4. wiring connections
(of the entire signaling system)

NOTE:

- Before troubleshooting, remove the following part(s):
 - 1) fuel tank
 - 2) front cowling
 - 3) air filter case
- Troubleshoot with the following special tool(s).



Pocket tester
90890-03132

EAS00738

1. Main, signaling system, hazard lighting and backup fuses

- Check the main, signaling system, hazard lighting and backup fuses for continuity. Refer to "CHECKING THE FUSES" in chapter 3.
- Are the main, signaling system, hazard lighting and backup fuses OK?

↓ YES

↓ NO

Replace the fuse(s).

EAS00739

2. Battery

- Check the condition of the battery. Refer to "CHECKING AND CHARGING THE BATTERY" in chapter 3. (Manual No.: 5PS1-AE1)



Minimum open-circuit voltage
12.8 V or more at 20°C

- Is the battery OK?

↓ YES

↓ NO

- Clean the battery terminals.
- Recharge or replace the battery.

EAS00749

3. Main switch

- Check the main switch for continuity. Refer to "CHECKING THE SWITCHES".
- Is the main switch OK?

↓ YES

↓ NO

Replace the main switch.

EAS00795

4. Wiring

- Check the entire signal system's wiring. Refer to "CIRCUIT DIAGRAM".
- Is the signaling system's wiring properly connected and without defects?

↓ YES

↓ NO

Check the condition of each of the signaling system's circuits. Refer to "CHECKING THE SIGNALING SYSTEM".

Properly connect or repair the signaling system's wiring.

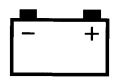

EAS00796

CHECKING THE SIGNAL SYSTEM

1. The horn fails to sound.

1. Horn switch

- Check the horn switch for continuity. Refer to “CHECKING THE SWITCHES”.
- Is the horn switch OK?



Replace the left handlebar switch.

2. Voltage

- Connect the pocket tester (DC 20 V) to the horn connector at the horn terminal as shown.

Positive tester probe → black/white ①
Negative tester probe → ground

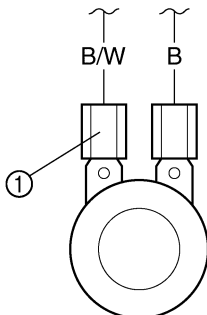

- Set the main switch to “ON”.
- Push the horn switch.
- Measure the voltage (DC 12 V) of black/white at the horn terminal.
- Is the voltage within specification?



The wiring circuit from the main switch to the horn connector is faulty and must be repaired.

3. Horn

- Disconnect the black connector at the horn terminal.
- Connect a jumper lead ① to the horn terminal and ground the jumper lead.
- Set the main switch to “ON”.
- Push the horn switch.
- Does the horn sound?

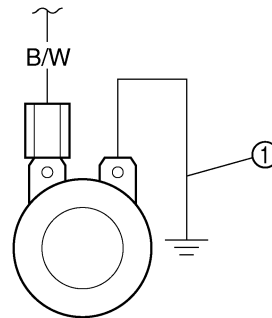

The horn is OK.

Replace the horn.

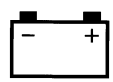

EAS00797

2. The tail/brake light fails to come on.

1. Tail/brake light bulb and socket

- Check the tail/brake light bulb and socket for continuity. Refer to “CHECKING THE BULBS AND BULB SOCKETS” in chapter 3. (Manual No.: 5PS1-AE1)
- Are the tail/ brake light bulb and socket OK?

↓ YES

↓ NO

Replace the tail/brake light bulb, socket or both.

2. Brake light switches

- Check the brake light switches for continuity. Refer to “CHECKING THE SWITCHES”.
- Is the brake light switch OK?

↓ YES

↓ NO

Replace the brake light switch.

3. Voltage

- Connect the pocket tester (DC 20 V) to the tail/brake light coupler (wire harness side) as shown.

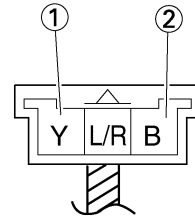

Positive tester probe → yellow ①
 Negative tester probe → black ②

- Set the main switch to “ON”.
- Pull in the brake lever or push down on the brake pedal.
- Measure the voltage (DC 12 V) of yellow ① on the tail/brake light coupler (wire harness side).
- Is the voltage within specification?

↓ YES

↓ NO

This circuit is OK.

The wiring circuit from the main switch to the tail/brake light coupler is faulty and must be repaired.

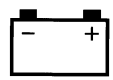

EAS00799

3. The turn signal light, turn signal indicator light or both fail to blink.

1. Turn signal indicator light bulb and socket

- Check the turn signal light bulb and socket for continuity. Refer to “CHECKING THE BULBS AND BULB SOCKETS” in chapter 3. (Manual No.: 5PS1-AE1)
- Are the turn signal light bulb and socket OK?

↓ YES

↓ NO

Replace the turn signal light bulb, socket or both.

2. Turn signal switch

- Check the turn signal switch for continuity. Refer to “CHECKING THE SWITCHES”.
- Is the turn signal switch OK?

↓ YES

↓ NO

Replace the left handlebar switch.

3. Voltage

- Connect the pocket tester (DC 20 V) to the turn signal relay coupler (wire harness side) as shown.

Positive tester probe → brown/green ①
Negative tester probe → ground

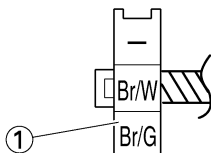

- Set the main switch to “ON”.
- Measure the voltage (DC 12 V) on brown/green ① at the turn signal relay coupler (wire harness side).
- Is the voltage within specification?

↓ YES

↓ NO

The wiring circuit from the main switch to the turn signal relay coupler is faulty and must be repaired.

4. Voltage

- Connect the pocket tester (DC 20 V) to the turn signal relay coupler (wire harness side) as shown.

Positive tester probe → brown/white ①
Negative tester probe → ground

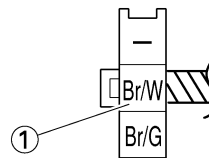

- Set the main switch to “ON”.
- Set the turn signal switch to “←” or “→”.
- Measure the voltage (DC 12 V) on brown/white ① at the turn signal relay coupler (wire harness side).
- Is the voltage within specification?

↓ YES

↓ NO

The turn signal relay is faulty and must be replaced.

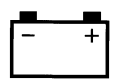

5. Voltage

- Connect the pocket tester (DC 20 V) to the turn signal light coupler or meter assembly coupler (wire harness side) as shown.

A Turn signal light
B Turn signal indicator light

Left turn signal light
 Positive tester probe → chocolate ①
 Negative tester probe → ground

Right turn signal light
 Positive tester probe → dark green ②
 Negative tester probe → ground

A

B

- Set the main switch to "ON".
- Set the turn signal switch to "←" or "→".
- Measure the voltage (DC 12 V) of the brown/white ① or blue/red ② at the turn signal light coupler (wire harness side).
- Is the voltage within specification?



This circuit is OK.



The wiring circuit from the turn signal switch to the turn signal light coupler (meter assembly coupler) is faulty and must be repaired.

EAS00800

4. The neutral indicator light fails to come on.

1. Neutral indicator light bulb and socket

- Check the neutral indicator light bulb and socket for continuity. Refer to "CHECKING THE BULBS AND BULB SOCKETS" in chapter 3. (Manual No.: 5PS1-AE1)
- Are the neutral indicator light bulb and socket OK?



Replace the neutral indicator light bulb, socket or both.

2. Neutral switch

- Check the neutral switch for continuity. Refer to "CHECKING THE SWITCHES".
- Is the neutral switch OK?



Replace the neutral switch.

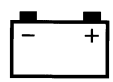

EAS00753

3. Starting circuit cut-off relay (diode)

- Disconnect the starting circuit cut-off relay from the wire harness.
- Connect the pocket tester ($\Omega \times 1$) to the starting circuit cut-off relay terminals as shown.
- Check the starting circuit cut-off relay for continuity.

| | |
|--|---------------|
| Tester positive probe → light green ① | Continuity |
| Tester negative probe → sky blue ② | |
| Tester positive probe → sky blue ② | No continuity |
| Tester negative probe → light green ① | |

NOTE: _____
When you switch the positive and negative tester probes, the readings in the above chart will be reversed.

- Are the tester readings correct?

↓ YES

↓ NO

Replace the starting circuit cut-off relay.

4. Voltage

- Connect the pocket tester (DC 20 V) to the meter assembly coupler (wire harness side) as shown.

Positive tester probe → brown ①
Negative tester probe → light green ②

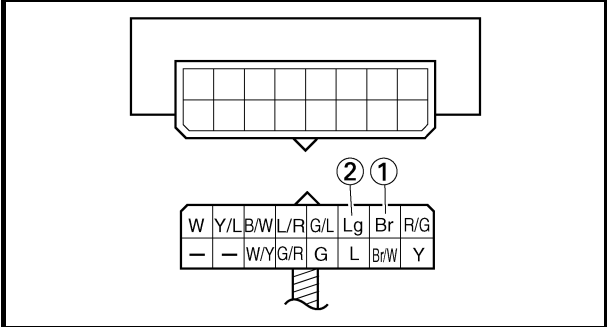

- Set the main switch to "ON".
- Measure the voltage (DC 12 V).
- Is the voltage within specification?

↓ YES

↓ NO

This circuit is OK.

The wiring circuit from the main switch to the meter assembly coupler is faulty and must be repaired.

EAS00802

5. The oil level warning light fails to come on.

1. Oil level warning light bulb and socket

- Check the oil level warning light bulb and socket for continuity. Refer to "CHECKING THE LEDs" in chapter 8. (Manual No.: 5PS1-AE1)
- Are the oil level warning light bulb and socket OK?

↓ YES

↓ NO

Replace the oil level warning light bulb, socket or both.

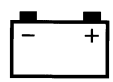

2. Engine oil level switch

- Drain the engine oil and remove the engine oil level switch from the oil tank.
- Check the engine oil level switch for continuity. Refer to “CHECKING THE SWITCHES”.
- Is the engine oil level switch OK?



Replace the engine oil level switch.

3. Voltage

- Connect the pocket tester (DC 20 V) to the meter assembly coupler (wire harness side) as shown.

Positive tester probe → brown ①
Negative tester probe → black/white ②

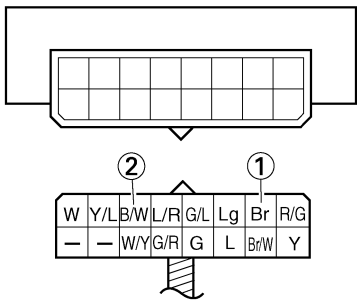

- Set the main switch to “ON”.
- Measure the voltage (DC 12 V) of brown ① and black/white ② at the meter assembly coupler.
- Is the voltage within specification?



The wiring circuit from the main switch to the meter assembly coupler is faulty and must be repaired.

4. Voltage

- Connect the pocket tester (DC 20 V) to the engine oil level switch coupler as shown.

Tester positive probe → white ①
Tester negative probe → black ②

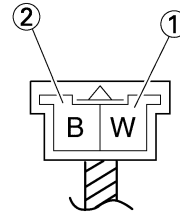

- Set the main switch to “ON”.
- Measure the voltage (5 V) of white ① and black ② at the oil level switch coupler.
- Is the voltage within specification?



This circuit is OK.

The wiring circuit from the meter assembly to the oil level switch coupler is faulty and must be repaired.

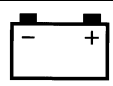

EAS00803

6. The fuel level gauge fails to operate.

1. Fuel sender

- Drain the fuel from the fuel tank and remove the fuel pump assembly from the fuel tank.
- Connect the pocket tester ($\Omega \times 1$) to the fuel sender as shown.

Positive tester probe → green ①
Negative tester probe → black/white ②

- Measure the fuel sender resistances.

NOTE: _____
 Measure the resistances when the float arm is in contact with the full position and empty position of the stopper.

Fuel sender resistance
 Full position of the float
 19 ~ 21 Ω at 20°C
 Empty position of the float
 139 ~ 141 Ω at 20°C

- Is the fuel sender OK?

↓ YES ↓ NO

Replace the fuel pump.

2. Voltage

- Connect the pocket tester (DC V 20) to the meter assembly (wire harness side) as shown.

Positive tester probe → green ①
Negative tester probe → black/white ②

- Set the main switch to "ON".
- Measure the voltage (DC 12 V) of green ① and black/white ② at the meter assembly coupler.
- Is the voltage within specification?

↓ YES ↓ NO

The wiring circuit from the fuel sender to the meter assembly coupler is faulty and must be repaired.

3. Voltage

- Connect the pocket tester (DC 20 V) to the meter assembly coupler as shown.

Tester positive probe → brown ①
Tester negative probe → black/white ②

- Set the main switch to "ON".
- Measure the voltage (12 V) of brown ① and black/white ② at the meter assembly coupler.
- Is the voltage within specification?

↓ YES ↓ NO

This circuit is OK.

Replace the meter assembly.

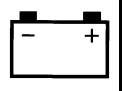

EAS00805

7. The clock fails to operate.

1. Voltage

- Connect the pocket tester (DC V 20) to the meter assembly (wire harness side) as shown.

Positive tester probe → brown ①
Negative tester probe → black/white ②

W Y/L B/W L/R G/L Lg Br R/G
 - - W/Y G/R G L B/W Y

- Set the main switch to "ON".
- Measure the voltage (DC 12 V).
- Is the voltage within specification?

↓ YES

↓ NO

Replace the meter assembly.

The wiring circuit from the main switch to the meter assembly coupler is faulty and must be repaired.

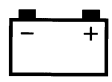

EAS00884

ANTI-LOCK BRAKE SYSTEM (ABS) CIRCUIT DIAGRAM

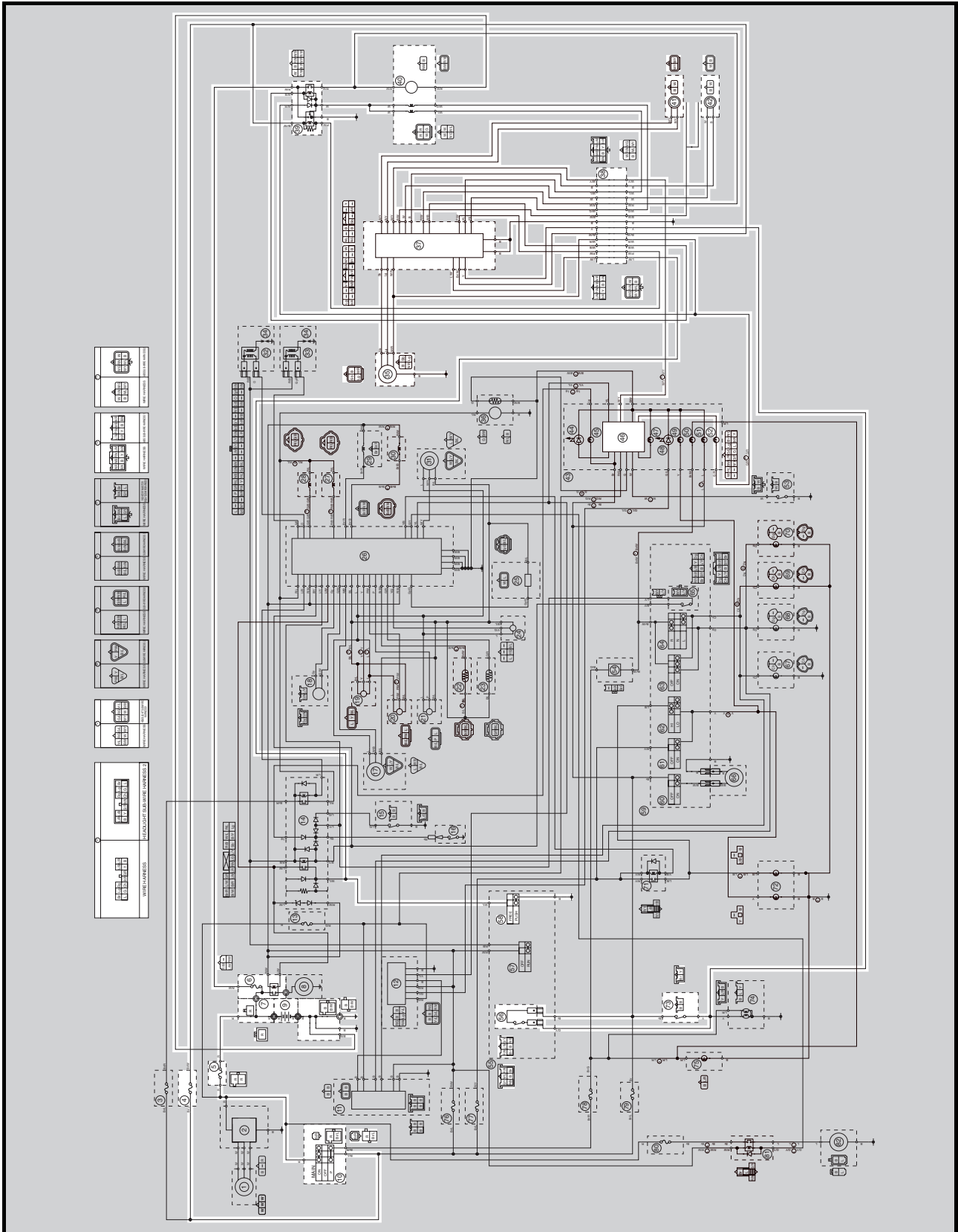

ANTI-LOCK BRAKE SYSTEM (ABS)

ELEC

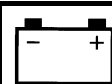

- ④ Fuse (ABS)
- ⑤ Fuse (main)
- ⑥ Fuse (ABS motor)
- ⑨ Battery
- ⑩ Main switch
- ③⑤ ABS test terminal
- ③⑦ ECU (ABS)
- ③⑧ ABS wire lead
- ③⑨ Fail safe relay
- ④⑩ Hydraulic unit
- ④① Front wheel sensor
- ④② Rear wheel sensor
- ④⑥ Multi-function meter
- ⑤② ABS indicator light
- ⑤⑥ Front brake light switch
- ⑤⑧ Start switch
- ⑦③ Rear brake light switch



EAS00882

ABS COMPONENTS

- ① Front brake hose (front brake master cylinder to hydraulic unit)
- ② ABS test coupler
- ③ ABS warning light
- ④ Front brake hose (hydraulic unit to front brake caliper)
- ⑤ Front wheel sensor
- ⑥ Front wheel sensor rotor
- ⑦ Electronic control unit (ECU)
- ⑧ Rear brake hose (hydraulic unit to rear brake caliper)
- ⑨ Rear brake hose (rear brake master cylinder to hydraulic unit)
- ⑩ Hydraulic unit
- ⑪ Rear wheel sensor rotor
- ⑫ Rear wheel sensor
- ⑬ Fuse box
- ⑭ Fail-safe relay

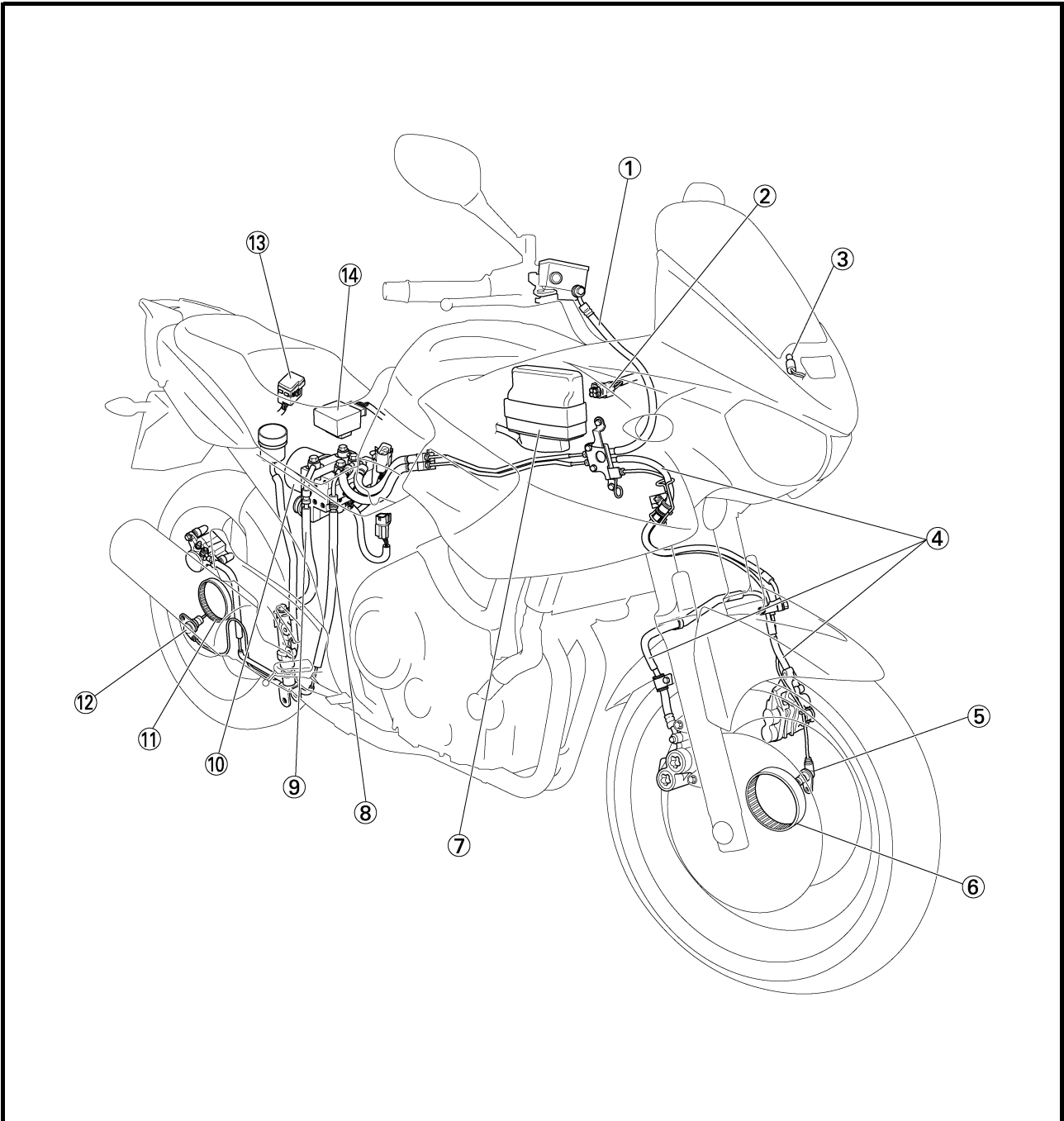

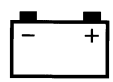

EAS00883

ABS CONNECTOR LOCATION CHART

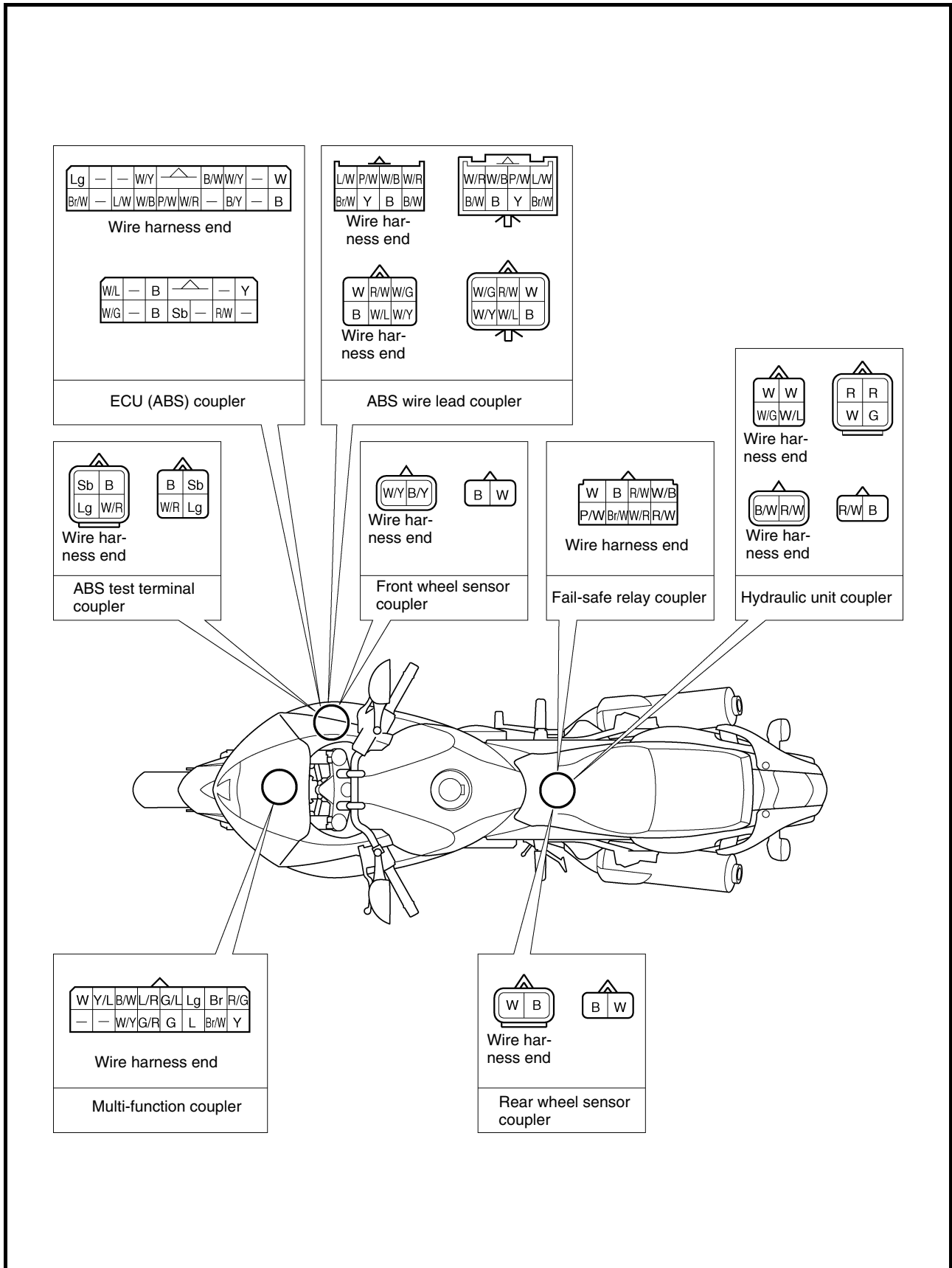

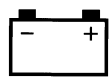

EAS00888

ECU (ABS) AND FAIL-SAFE RELAY

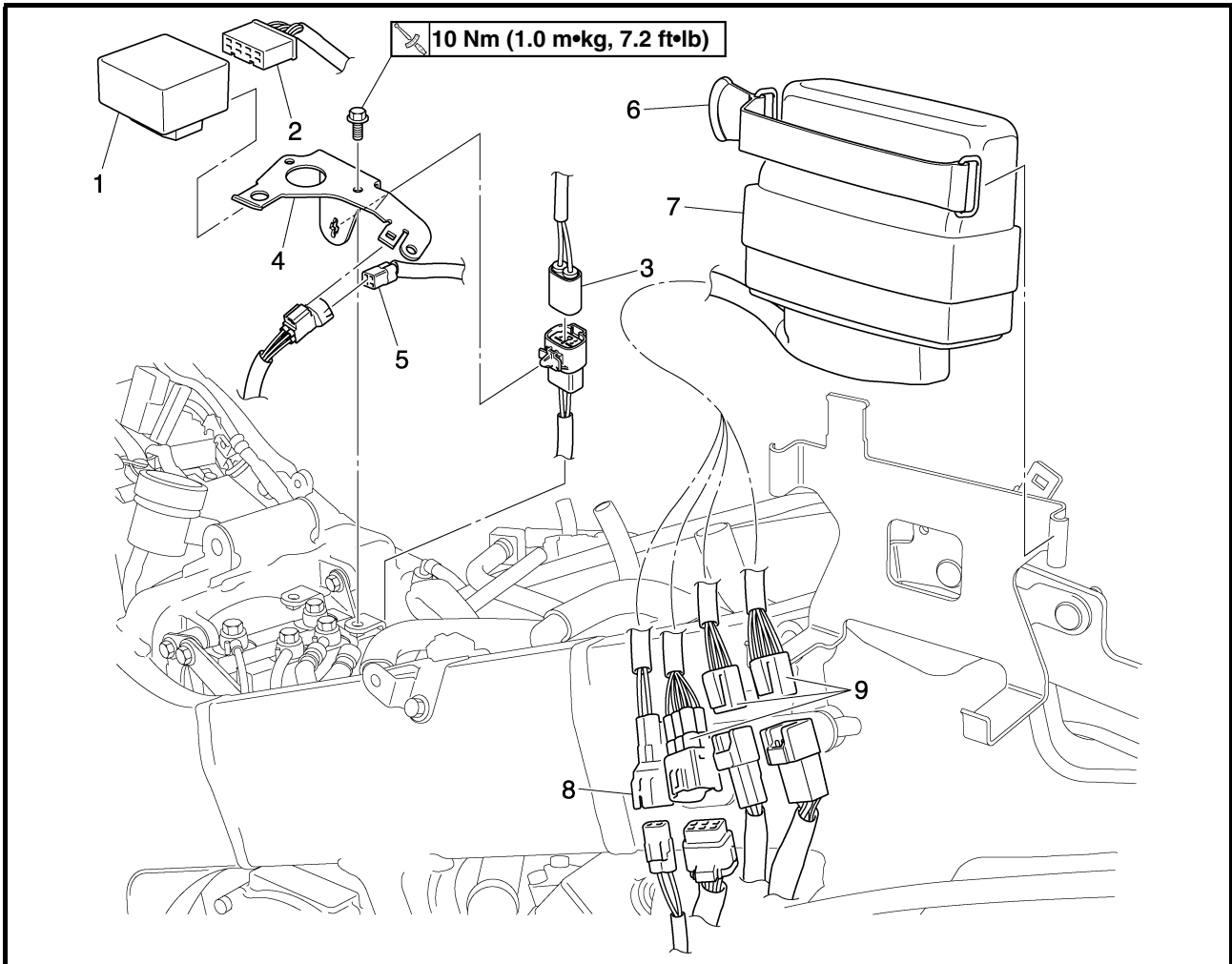

| Order | Job/Part | Q'ty | Remarks |
|-------|---|------|--|
| | Removing the ECU (ABS) and fail-safe relay | | Remove the parts in the order listed. |
| | Side cowling (right) | | Refer to "FRONT COWLINGS" in chapter 3. (Manual No.: 5PS1-AE1) |
| | Seat | | Refer to "SEAT" in chapter 3. (Manual No.: 5PS1-AE1) |
| | Fuel tank | | Refer to "FUEL TANK" in chapter 3. (Manual No.: 5PS1-AE1) |
| 1 | Fail-safe relay | 1 | |
| 2 | Fail-safe relay coupler | 1 | Disconnect. |
| 3 | ABS motor coupler | 1 | Disconnect. |
| 4 | Relay stay | 1 | |
| 5 | Hydraulic unit solenoid coupler | 1 | Disconnect. |
| 6 | Band | 1 | |
| 7 | ECU (ABS) | 1 | |
| 8 | Front wheel sensor coupler | 1 | Disconnect. |

ANTI-LOCK BRAKE SYSTEM (ABS)

ELEC

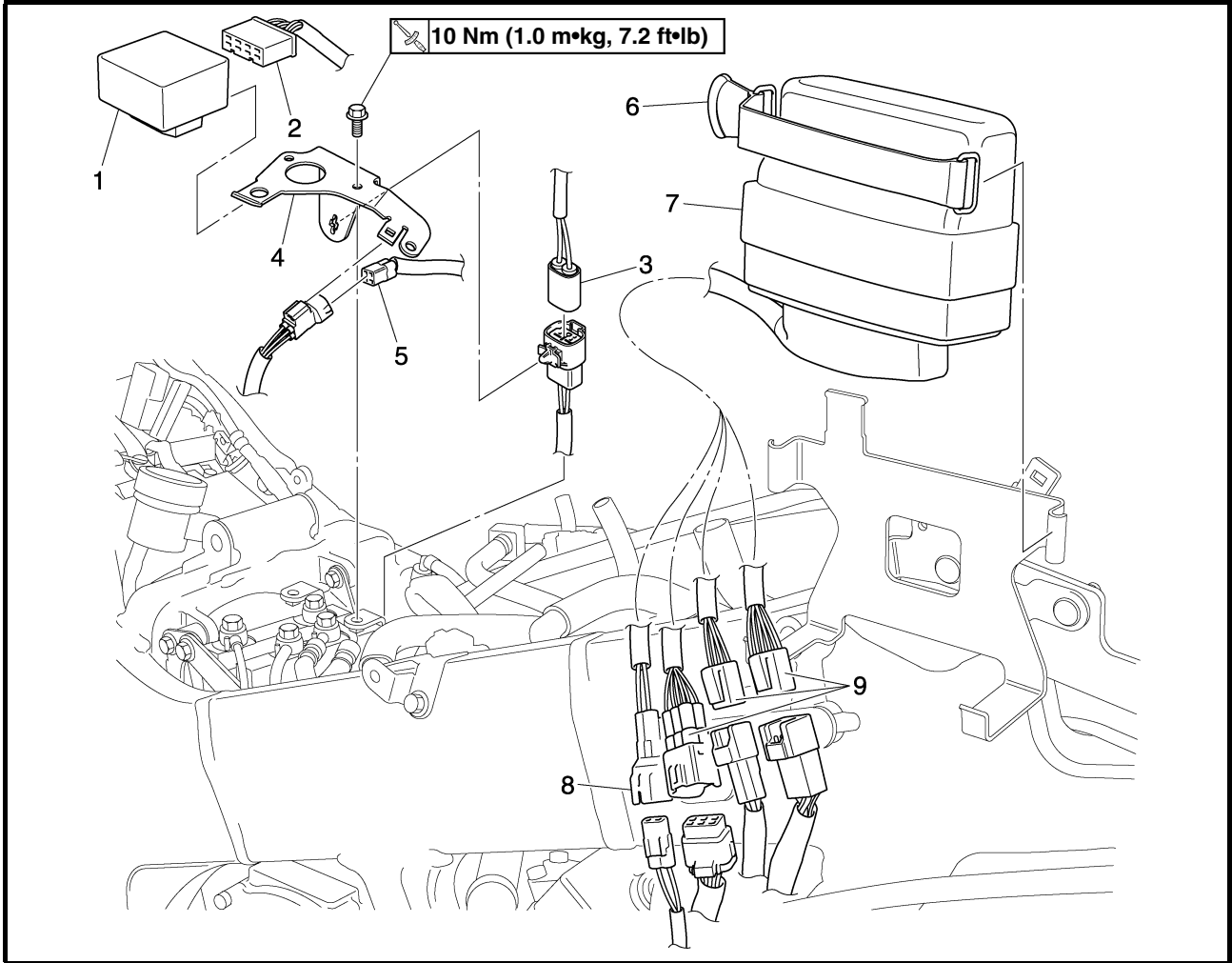
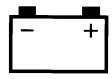

| Order | Job/Part | Q'ty | Remarks |
|-------|-------------------|------|---|
| 9 | ECU (ABS) coupler | 3 | Disconnect. For installation, reverse the removal procedure. |

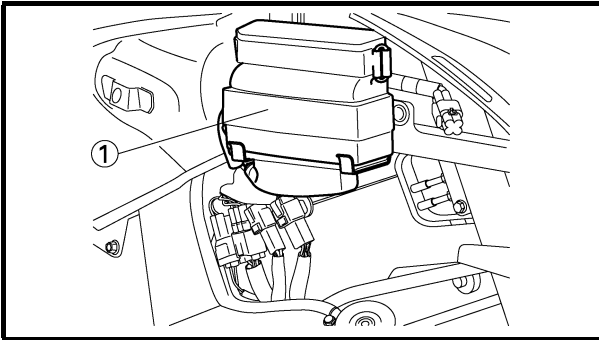
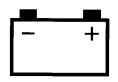

Maintenance of the ECU (ABS)

• Removing the ECU (ABS)

1. Remove:
 - ECU (ABS) ①

NOTE: _____

When removing the ECU (ABS), take care not to damage the ECU (ABS) or ECU (ABS) couplers.

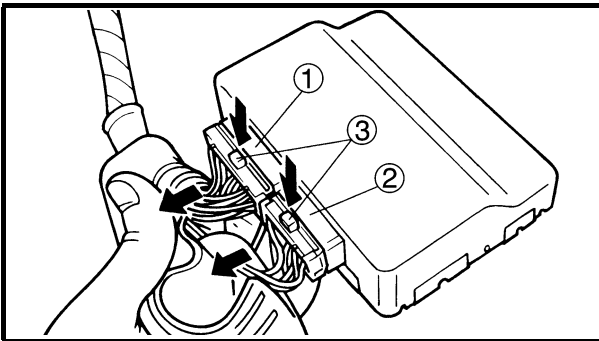

2. Remove:
 - ECU (ABS) coupler ①
 - ECU (ABS) coupler ②

NOTE: _____

Do not pull the ECU (ABS) leads to remove the ECU (ABS) couplers.

Always press on the locks ③ to disconnect the ECU (ABS) couplers from the ECU (ABS).

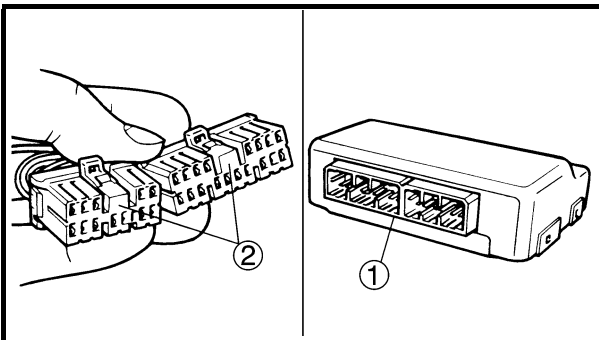

• Checking the ECU (ABS)

1. Check:
 - ECU (ABS) terminals ①
Cracks/damage → Replace the ECU (ABS).
 - ECU (ABS) coupler terminals ②
Defective connections/contamination/disconnections → Repair or clean.

NOTE: _____

If the ECU (ABS) coupler terminals are clogged with mud or dirt, clean with compressed air.

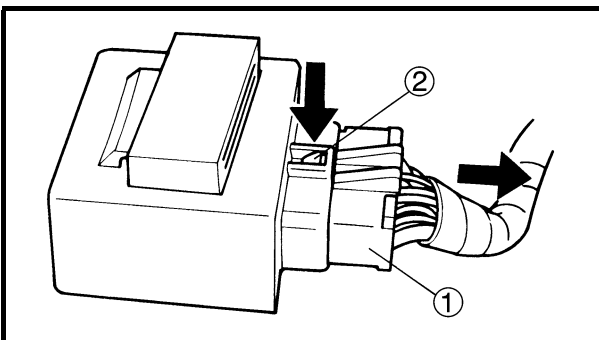

Maintenance of the ABS fail-safe relay

• Removing the fail-safe relay

1. Remove:
 - ABS fail-safe relay coupler ①

NOTE: _____

Do not pull the ABS fail-safe relay leads to remove the ABS fail-safe relay coupler.

Always press on the lock ② to disconnect the ABS fail-safe relay coupler from the ABS fail-safe relay.

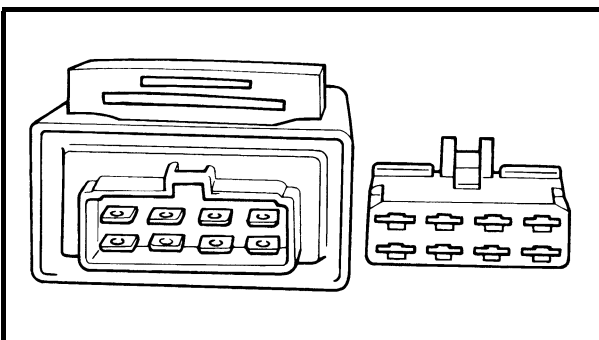

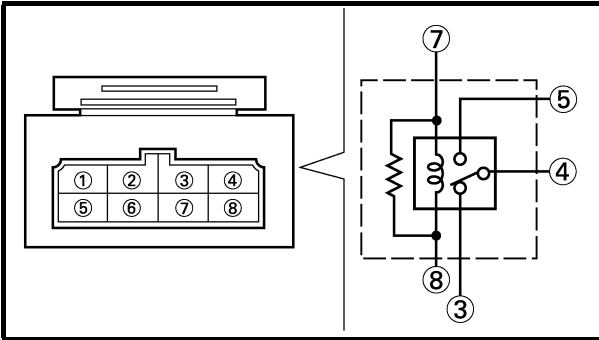
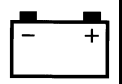

Operation of solenoid relay

| Terminal number | ③ | ④ | ⑤ | ⑦ | ⑧ |
|--|---|---|---|---|---|
| Normal condition | ○ | ○ | | ○ | ○ |
| Connect the battery to terminals ⑦ and ⑧ | | ○ | ○ | | |

○—○ Continuity

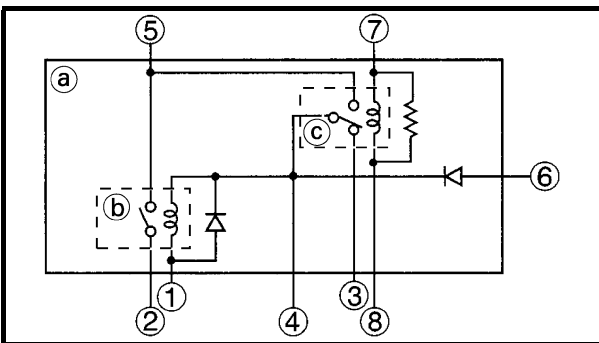

•Checking the fail-safe relay

1. Check:

- solenoid relay for continuity

Connect the pocket tester ($\Omega \times 1$) to the terminals.

Check for continuity between terminals ③ and ④ of the solenoid relay.

Tester positive probe → Terminal ③

Tester negative probe → Terminal ④

Tester reading is " ∞ ". → Replace the fail-safe relay.

- Check for continuity between terminals ⑦ and ⑧ of the solenoid relay.

Tester positive probe → Terminal ⑦

Tester negative probe → Terminal ⑧



Solenoid relay resistance

150 ~ 450 Ω

Tester reading is " ∞ ". → Replace the fail-safe relay.

- Connect the positive battery terminal to terminal ⑦ and the negative battery terminal to terminal ⑧, and then check for continuity between terminals ④ and ⑤ of the solenoid relay.

Tester positive probe → Terminal ④

Tester negative probe → Terminal ⑤

Tester reading is " ∞ ". → Replace the fail-safe relay.

CAUTION:

When connecting the solenoid relay and battery terminals, be careful not to short-circuit the positive and negative battery terminals.

- ① Fail-safe relay
- ② ABS motor relay
- ③ Solenoid relay

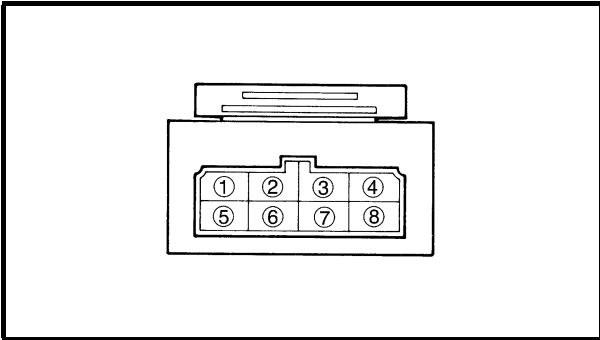
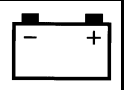

Operation of motor relay ○—○ Continuity

| Terminal number | ① | ② | ⑤ | ⑥ | |
|---|---|---|---|---|--|
| Normal condition | ○ | | | ○ | |
| Connect the battery to ⑥ and ① terminal | | ○ | ○ | | |

2. Check:

- ABS motor relay for continuity
Connect the pocket tester ($\Omega \times 1$) to the terminals of the ABS motor relay.
Check for continuity between terminals ① and ⑥ of the ABS motor relay.
Tester positive probe → Terminal ①
Tester negative probe → Terminal ⑥



ABS motor relay resistance
50 ~ 150 Ω

Tester reading is “∞”. → Replace the fail-safe relay.

CAUTION: _____

Do not reverse the connections. If the pocket tester leads are connected in reverse to terminals ① and ⑥, a correct pocket tester reading cannot be obtained.

- Connect the positive battery terminal to terminal ⑥ and the negative battery terminal to terminal ①, and then check for continuity between terminals ② and ⑤ of the ABS motor relay.

Tester positive probe → Terminal ②
Tester negative probe → Terminal ⑤

Tester reading is “∞”. → Replace the fail-safe relay.

CAUTION: _____

- Be sure to connect the pocket tester positive and negative probes correctly. If the pocket tester probes are connected in reverse, the diode of the fail-safe relay will be broken.
- When connecting the battery and the ABS motor relay terminals, be careful not to short-circuit the positive and negative battery terminals.

ANTI-LOCK BRAKE SYSTEM (ABS)

ELEC

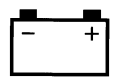

TROUBLESHOOTING

- **ABS warning light fail to come on.**
- **All ABS warning and other indicator lights fail to come on.**
- **ABS warning light continues to come on.**

Check:

1. ABS motor, ABS, main and signal fuses.
2. Battery.
3. Main switch.
4. Wiring (of the entire anti-lock brake system).

NOTE:

- Before troubleshooting, remove the following part(-s):
 - 1) side cowlings (left and right)
 - 2) front cowling
 - 3) seat
 - 4) fuel tank
 - 5) meter assembly
- Troubleshoot with the following special tool(-s).



Pocket tester
90890-03112

EB802400

1. ABS motor, ABS, main and signal fuses

- Check the ABS motor, ABS, main and signal fuses for continuity. Refer to "CHECKING THE FUSES" in chapter 3. (Manual No.: 5PS1-AE1)
- Are the ABS motor, ABS, main and signal fuses OK?

↓ YES

↓ NO

Replace the fuse(-s).

EB802401

2. Battery

- Check the condition of the battery. Refer to "CHECKING AND CHARGING THE BATTERY" in chapter 3. (Manual No.: 5PS1-AE1)



Open-circuit voltage
12.8 V or more at 20°C

- Is the battery OK?

↓ YES

↓ NO

- Clean the battery terminals.
- Recharge or replace the battery.

EB802411

3. Main switch

- Check the main switch for continuity. Refer to "CHECKING THE SWITCHES".
- Is the main switch OK?

↓ YES

↓ NO

Replace the main switch.

EAS00795

4. Wiring

- Check the entire anti-lock brake system's wiring. Refer to "CIRCUIT DIAGRAM".
- Is the anti-lock brake system's wiring properly connected and without defects?

↓ YES

↓ NO

Check the condition of each of the anti-lock brake system's circuits. Refer to "CHECKING THE ANTI-LOCK BRAKE SYSTEM".

Properly connect or repair the anti-lock brake system's wiring.

ANTI-LOCK BRAKE SYSTEM (ABS)

ELEC

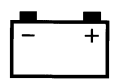

CHECKING THE ANTI-LOCK BRAKE SYSTEM

1. Only the ABS warning light fail to come on when the main switch is turned ON.

1. ABS coupler and wire harness.

- Check the ABS coupler and wire harness for continuity.
- Check the ECU and ABS wire harness for continuity. Refer to "CIRCUIT DIAGRAM".
- Is the anti-lock brake system's wiring properly connected and without defects?

↓ OK

↓ NO

- Properly connect or replace the ABS coupler and wire harness.
- Properly connect or replace the ECU and fail-safe relay and wire harness.

2. ABS warning light

- Connect the ABS test coupler and ABS test coupler adapter.

ABS test coupler adapter warning light terminal (white/red) ①
→ **Battery Negative lead ②**

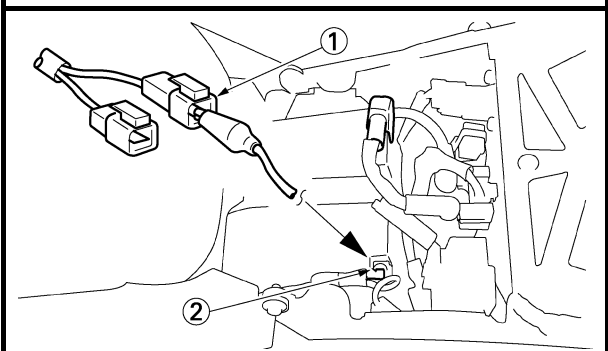

• Does the ABS warning light come on?

↓ OK

↓ NO

Replace the ABS warning light.

3. ABS warning light circuit.

- Remove the ECU coupler and check the continuity at the white/red terminal on the ECU side and the test coupler adapter side of the wire harness.
- Is the ECU continuity OK?

↓ YES

↓ NO

Replace the ECU.

Properly connect or replace the ABS coupler and wire harness.

2. All ABS warning and other indicator lights fail to come on.

1. Main switch.

- Check the main switch for continuity. Refer to "CHECKING THE SWITCHES".
- Is the main switch OK?

↓ YES

↓ NO

Replace the main switch.

2. Battery.

- Check the condition of the battery. Refer to "CHECKING AND CHARGING THE BATTERY" in chapter 3. (Manual No.: 5PS1-AE1)



Open-circuit voltage
12.8 V or more at 20°C

• Is the battery OK?

↓ YES

↓ NO

- Clean the battery terminals.
- Recharge or replace the battery.

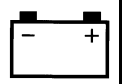

3. Main fuse.

- Check the main fuse for continuity.
Refer to “CHECKING THE FUSES” in chapter 3. (Manual No.: 5PS1-AE1)
- Is the main fuse OK?



Replace the fuse.

4. Wiring

- Check the entire anti-lock brake system's wiring.
Refer to “CIRCUIT DIAGRAM”.
- Is the anti-lock brake system's wiring properly connected and without defects?



Check the condition of each of the anti-lock brake system circuits.
Refer to “CHECKING THE ANTI-LOCK BRAKE SYSTEM”.

Properly connect or repair the anti-lock brake system's wiring.

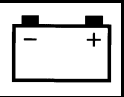

3. ABS warning light continues to come on.

1) Check the ABS fuse

- Blown fuse → Replace

2) Check the battery voltage

The voltage should be always higher than the regulated voltage in order to operate the ABS correctly. If the power voltage goes lower than 10 V, the ABS warning light comes on and ABS operation stops. When the power voltage recovers to be higher than 10 V, the system resumes its operation.

The fact that the voltage lowered less than 10 V means that something is defective with the magnet, battery or rectifier regulator.

Correct the malfunction following the normal instructions and regulate the system to operate in the normal condition.

3) Check the Electronic Control Unit (ECU) in the side cowling.

Refer to “FRONT COWLINGS” in chapter 3. (Manual No.: 5PS-AE1)

Is the coupler securely connected?

- Connected → Inspect the malfunction by the ABS self diagnosis
- Not connected → Connect the ABS coupler again.

4. ABS warning light flashes

1) Slipping of one wheel (Flash pattern: Lighting ON for 0.75 sec./OFF for 0.25 sec.)

Causes to those cases in which the ABS warning light flashed while driving, but “it turned to be normal”, or “the ABS warning light flashed but flashing stopped when the main switch was turned OFF and then turned ON again” could be thought as follows:

- (1) Rear wheel slipped. → The system is normal.
- (2) Demonstrated wheelie. → The system is normal.
- (3) The vehicle in question ran continually on the extremely bumpy road. → The system is normal.

2) ABS stops by the Electronic Control Unit (ECU)

This is the case when the Electronic Control Unit (ECU) judged that the system should stop because it has been exposed to the extremely strong radio wave, static electricity or radioactivity.

3) Defective condition of the brake light switch section (Flash pattern: Lighting ON for 0.25 sec./OFF for 0.75 sec.)

Check the brake light switch (front and rear) without starting the engine.

Check whether the brake lights up or not when the front and rear brakes are engaged respectively.

(1) It reacts only to one brake.

→ The coupler of brake switch has come off. (Refer to “WIRING DIAGRAM”.)

→ The brake light switch on the side that the brake light does not react is out of order.

(2) It does not react to either of brakes.

→ It could be thought that the wire harness is disconnected or the fuse is blown. (Refer to “WIRING DIAGRAM”.)

(3) Brake light comes on.

→ It could be thought that the coupler between the ABS harness and wire harness is not connected. (Refer to “ABS CONNECTOR LOCATION CHART”.)

(4) Possible causes other than these cases.

→ Disconnection or short-circuit between the meter and ECU (ABS).

4) ABS continual control while braking

- It may flash if the ABS operation time became longer while braking. (Flash pattern: Lighting ON for 0.25 sec./OFF for 0.75 sec.)

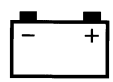

TROUBLESHOOTING BY THE SELF DIAGNOSIS

Arrangement and the function of test couplers

- ECU becomes the malfunction diagnostic mode when the T/C terminal is grounded.
- Malfunction code which the ECU generated in the malfunction diagnostic mode (rise and fall of voltage) is output at the T/F terminal.
- ABS warning light terminal is used when checking the ABS warning light circuit.
- To ground the T/C terminal, connect the test coupler adapter with the test coupler. Before connecting, check if the battery is sufficiently charged.

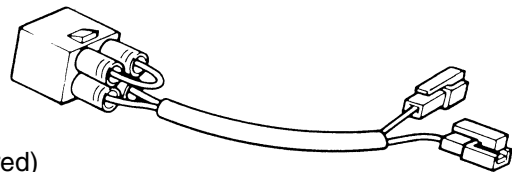
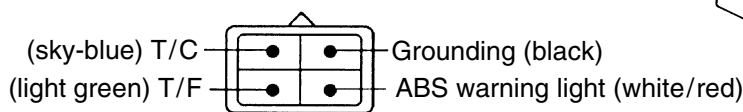

Test coupler adapter

MALFUNCTION CHECK BY THE ABS SELF DIAGNOSIS (PAST MALFUNCTION)

Remove the side cowling (right) and check the location of test coupler ①. Remove the protective cap and connect the ABS test coupler adapter ② to the test coupler. The T/C terminal (sky-blue) is now connected to the ground.

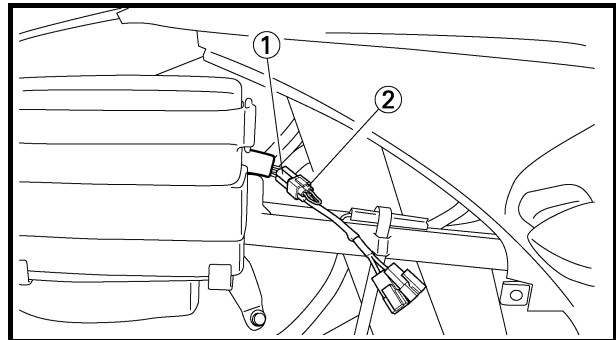
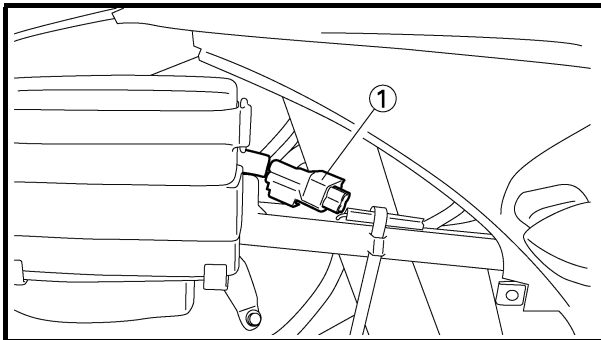

1) Indicate the malfunction code (Example: malfunction code 11)

Multifunction display

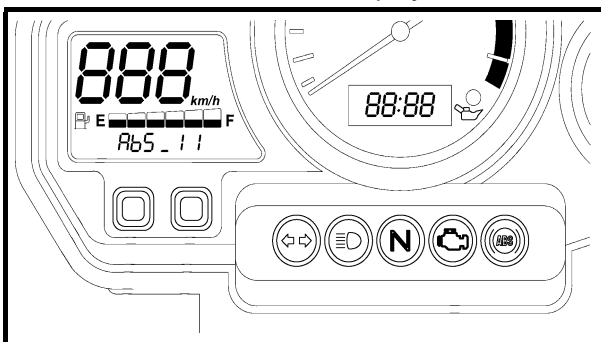

2) ABS warning light flashes every 0.5 second for more than 6 seconds.

→ P108, 109

If the ABS warning light flashes every 0.5 second, the malfunction code of a past malfunction has not been stored in the memory of the ECU (ABS). If a malfunction code is displayed on the multifunction display, the ABS warning light flashes. Make sure that the customer understands the possible conditions when the ABS warning light comes on.

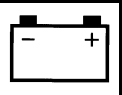

MALFUNCTION CHECK BY THE ABS SELF DIAGNOSIS (PRESENT MALFUNCTION)

NOTE:

Before proceeding to read the part of “Arrangement and the function of test coupler”.

Remove the battery cover and check the location of test coupler. Connect the test coupler adapter with the test coupler in order to ground the T/C terminal (sky-blue). (Figure-[A])

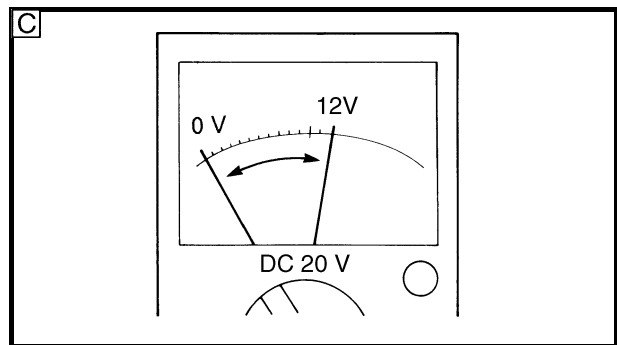
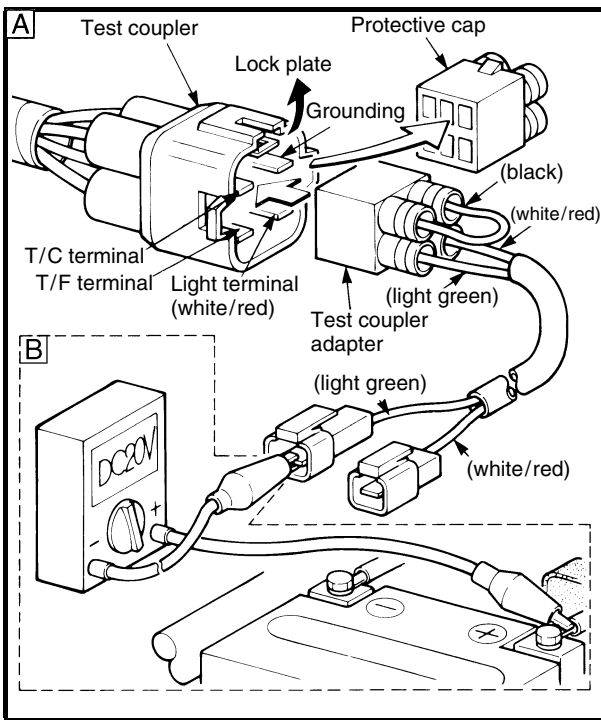

Set the range of pocket tester to DC20V. Connect the negative (-) terminal of tester to the T/F terminal (light green) and positive (+) terminal to the positive (+) terminal of battery. (Figure-[B])
Read the tester indication. (Figure-[C])

As an example, “10 digits/1 digit pattern” of tester reading is shown below.

This example is the pattern which shows malfunction code 12.

This example is the pattern which shows malfunction code 21.

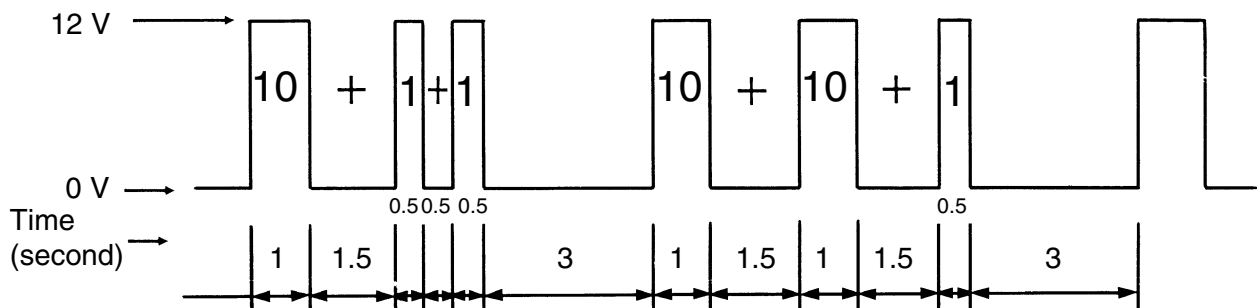

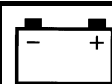

• Diagnosis by the malfunction code

Malfunction codes are used to determine the malfunctions that have occurred. (Refer to “P107 ABS malfunction check by the ABS self-diagnosis (past malfunction)” and “P108 ABS malfunction check by the ABS self-diagnosis (present malfunction)”.) The malfunction codes are explained in the following table.

NOTE:





Record all of the malfunction codes displayed and check the check points.

| Malfunction code | Problem | Check point | Reference |
|-------------------------|---|---|---|
| 11 *1 | Front wheel sensor signal is not received properly. <div style="text-align: center;"> </div> | <ul style="list-style-type: none"> • Installation of the front wheel sensor • Front wheel sensor lead and coupler • ABS wire harness circuit • Front wheel sensor rotor | Malfunction code 11 (P111) |
| 12 | Rear wheel sensor signal is not received properly. <div style="text-align: center;"> </div> | <ul style="list-style-type: none"> • Installation of the rear wheel sensor • Rear wheel sensor lead and coupler • ABS wire harness circuit • Rear wheel sensor rotor | Malfunction code 12 (P111) |
| 13 (front) 14 (rear) | Incorrect signal is detected by the front (13) or rear (14) wheel sensor. <div style="text-align: center;"> </div> | <ul style="list-style-type: none"> • Wheel sensor installation • Wheel sensor housings • Wheel sensor rotors | Malfunction codes 13 (front wheel) and 14 (rear wheel) (P112) |
| 15 (front) 16 (rear) | No continuity in the front or rear wheel sensor circuits <div style="text-align: center;"> </div> | <ul style="list-style-type: none"> • Continuity of sensor circuits • ABS wire harness circuit • Connection of sensor coupler | Malfunction codes 15 (front wheel sensor) and 16 (rear wheel sensor) (P112) |
| 21 | Hydraulic unit solenoid circuit is broken or short-circuited. <div style="text-align: center;"> </div> | <ul style="list-style-type: none"> • ABS wire harness circuit • Hydraulic unit solenoid coupler • Hydraulic unit solenoid | Malfunction code 21 (P112) |
| 31 | Disconnection is detected on the system of fail-safe relay and hydraulic unit solenoid coupler. <div style="text-align: center;"> </div> | <ul style="list-style-type: none"> • ABS wire harness circuit • Fail-safe relay circuit • Hydraulic unit solenoid coupler | Malfunction code 31 (P113) |
| 32 | Defective operation of the fail-safe relay is detected. <div style="text-align: center;"> </div> | <ul style="list-style-type: none"> • Fail-safe relay • ABS wire harness circuit | Malfunction code 32 (P113) |
| 33 | Defective operation of the ABS motor is detected. (ABS motor stops and will not rotate.) <div style="text-align: center;"> </div> | <ul style="list-style-type: none"> • ABS wire harness circuit • ABS motor coupler • Fail-safe relay • ABS motor circuit | Malfunction code 33 (P114) |

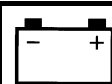
ANTI-LOCK BRAKE SYSTEM (ABS)

ELEC

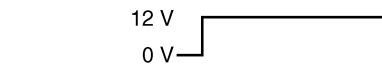

| Malfunction code | Problem | Check point | Reference |
|--|--|---|-------------------------------------|
| 34 | Defective operation of the ABS motor is detected. (ABS motor keeps running and will not stop.)  | <ul style="list-style-type: none"> • Fail-safe relay • ABS wire harness circuit • ABS motor circuit | Malfunction code 34 (P114) |
| 41 | Front wheel will not recover from the locking tendency even though the signal is continuously transmitted from the ECU (ABS) to release the hydraulic state (when the battery voltage is normal).  | <ul style="list-style-type: none"> • Brake dragging • Hydraulic unit operation test 2 (Refer to P71.) • Front wheel brake line | Malfunction code 41 (P115) |
| 42 | Rear wheel will not recover from the locking tendency even though the signal is continuously transmitted from the ECU (ABS) to release the hydraulic state (when the battery voltage is normal).  | <ul style="list-style-type: none"> • Brake dragging • Hydraulic unit operation test 2 (Refer to P71.) • Rear wheel brake line | Malfunction code 42 (P116) |
| 51 | Front wheel will not recover from the locking tendency even though the signal is continuously transmitted from the ECU (ABS) to release the hydraulic state (when the battery voltage is low).  | <ul style="list-style-type: none"> • Brake dragging • Hydraulic unit operation test 2 (Refer to P71) • Front wheel brake line • Battery voltage | Malfunction code 51 (P118) |
| 52 | Rear wheel will not recover from the locking tendency even though the signal is continuously transmitted from the ECU (ABS) to release the hydraulic state (when the battery voltage is low).  | <ul style="list-style-type: none"> • Brake dragging • Hydraulic unit operation test 2 (Refer to P71.) • Rear wheel brake line • Battery voltage | Malfunction code 52 (P119) |
| Present malfunction (test always indicates 12 V) | ECU (ABS) may be malfunctioning  | <ul style="list-style-type: none"> • ABS wire harness circuit (test coupler circuits) • ECU (ABS) (Replace) | Maintenance of the ECU (ABS) (P100) |

*1 Malfunction code 11 is indicated if the rear wheel rotates for more than 20 seconds with the front wheel stopped.

NOTE:

Malfunction code 15 (front wheel sensor) or 16 (rear wheel sensor) is displayed if a defective connection to either the front or rear sensor is detected whether or not the motorcycle is ridden.

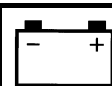

• **Malfunction code 11 (Front wheel sensor signal is not received correctly.)**

Set the main switch to “OFF”, then back to “ON” after removing the test coupler adaptor.

1) ABS warning light remains on.

→ Defective connection in the front wheel sensor circuit.

- Front wheel sensor coupler is disconnected. → P51
- Front wheel sensor lead or coil is broken. → P51
- Sub-wire harness (ABS) sensor circuit is broken. → (Refer to “CIRCUIT DIAGRAM”).
- ECU (ABS) coupler terminal is disconnected. → P100

2) ABS warning light comes on for 2 seconds, then goes off.

① With the front wheel stopped, the rear wheel was rotated for more than 20 seconds. This is not a malfunction.

② A signal is not generated at the front wheel sensor.

- Front wheel sensor is not installed properly. → P51
- Front wheel sensor rotor is defective. → P51

③ Front wheel sensor circuit is short-circuited.

- Front wheel sensor or lead is short-circuited. → P51
- Sub-wire harness (ABS) sensor circuit is short-circuited. → (Refer to “CIRCUIT DIAGRAM”).

④ Front wheel sensor output drops.

- Sensor signal output may drop due to failure of the bearings, wheel axle, wheel or sensor housing of the front wheel. Check these components when installed for looseness, distortion, and bends.

• **Malfunction code 12 (Rear wheel sensor signal is not received correctly.)**

Set the main switch to “OFF”, then back to “ON”.

1) ABS warning light remains on.

→ Defective connection in the rear wheel sensor circuit.

- Rear wheel sensor coupler is disconnected. → P55
- Rear wheel sensor lead or coil is broken. → P55
- Sub-wire harness (ABS) sensor circuit is disconnected. → (Refer to “CIRCUIT DIAGRAM”).
- ECU (ABS) coupler terminal is disconnected. → P100

2) ABS warning light comes on for 2 seconds, then goes off.

① With the rear wheel stopped, the front wheel was rotated at a speed faster than 11 km/h. This is not a malfunction.

② A signal is not generated at the rear wheel sensor.

- Rear wheel sensor is not installed properly. → P55
- Rear wheel sensor rotor is defective. → P55

③ Rear wheel sensor circuit is short-circuited.

- Rear sensor or lead is short-circuited. → P55
- Sub-wire harness (ABS) sensor circuit is short-circuited. → (Refer to “CIRCUIT DIAGRAM”).

④ Rear wheel sensor output drops

- Sensor signal output may drop due to failure of the bearings, wheel, or sensor housing of the rear wheel. Check these components when installed for looseness, distortion, and bends.

NOTE:

If the motorcycle is ridden on extremely uneven roads continuously, the ABS warning light may flash and malfunction code 11 or 12 may be recorded depending on the condition.

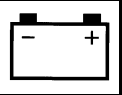

• **Malfunction codes 13 (front wheel) and 14 (rear wheel) (Incorrect signal is detected from either the front or rear wheel.)**

- 1) The wheel sensors or sensor rotors are not properly installed.
 - ① Installation of the front or rear wheel sensor
 - Check that the wheel sensor is properly installed in the housing. → P51, 55
 - Check if there is looseness between the housing and the wheel. → P51, 55
 - ② Installation of the front or rear wheel sensor rotor
 - Check that the sensor rotor is correctly pressed in the wheel. → P51, 55
 - Check the rotor and inside the rotor housing for foreign materials. → P51, 55
- 2) Teeth surfaces of the sensor rotors are defective.
 - Check for flaws on the teeth surfaces of the front or rear wheel sensor rotors. Also, check for any foreign materials. → P51, 55
- 3) Sensor output has dropped.
 - Sensor signal output may drop due to failure of the bearings, wheel axle, wheel or sensor housing of the front or rear wheel. Check these components when installed for looseness, distortion, and bends.

• **Malfunction codes 15 (front wheel sensor) and 16 (rear wheel sensor) (No continuity in the sensor circuits.)**

Broken front or rear wheel sensor circuit is detected.

- Front or rear wheel sensor coupler is broken. → P51, 55
- Front or rear wheel sensor or lead is broken. → P51, 55
- Sub-wire harness (ABS) sensor circuit is broken. → (Refer to “CIRCUIT DIAGRAM”).
- Sub-wire harness (ABS) is disconnected from the ECU (ABS) coupler terminal. → P100

NOTE:

- Check that both the front and rear wheel sensor couplers are connected securely.
- If the motorcycle is ridden after malfunction code 15 (front wheel sensor) or 16 (rear wheel sensor) is displayed, the malfunction code will be overwritten from 15 to 11 (front wheel sensor signal) or from 16 to 12 (rear wheel sensor signal).

• **Malfunction code 21 (Hydraulic unit solenoid circuit is broken or short-circuited.)**

Check the following:

- 1) Hydraulic unit solenoid coupler
 - Check if the hydraulic unit solenoid coupler terminal is disconnected. (Refer to “ABS COUPLERS”.)
- 2) Hydraulic unit solenoid
 - Check the front and rear wheel solenoids for continuity → P59
 - Check the insulation of all solenoid terminals and the negative battery terminal. → P59
- 3) Sub-wire harness (ABS)
 - Check the hydraulic unit solenoid circuits for continuity. (See the illustration below.)

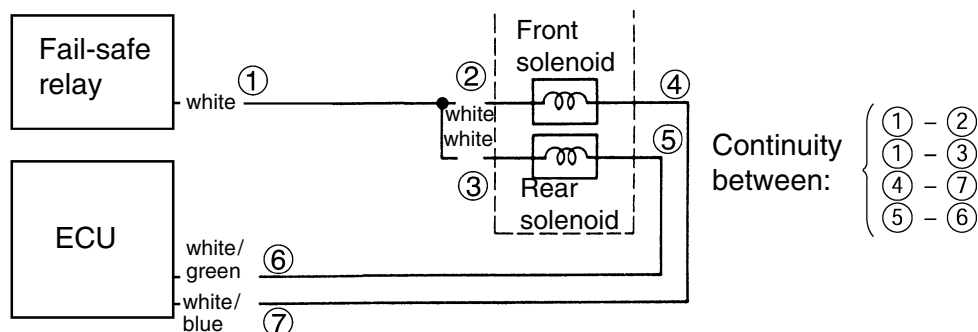

- Check the insulation of the hydraulic unit solenoid circuits and the negative battery terminal.

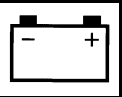

• Malfunction code 31 (Disconnection is detected between the fail-safe relay and the hydraulic unit solenoid.)

Check the following:

- 1) ABS motor fuse
 - Check if the ABS motor fuse beside the battery is blown.
- 2) Hydraulic unit solenoid coupler
 - Check if the hydraulic unit solenoid coupler located in the right side cover is connected properly. (Refer to “ABS CONNECTOR LOCATION CHART”.)
- 3) Sub-wire harness (ABS)
 - Check the pink/white leads between the ECU (ABS) and the fail-safe relay for continuity. (Refer to “CIRCUIT DIAGRAM”.)
 - ECU (ABS) coupler terminal (pink/white) is disconnected. → P100
 - Check the white leads between ① and ②, and between ① and ③ of the hydraulic unit solenoid circuits for continuity.

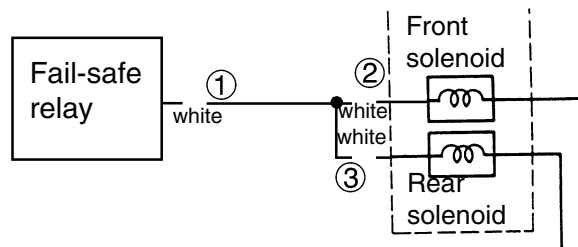

4) Fail-safe relay

- Check if the fail-safe relay operates correctly. → P100

5) Wire harness

- Check for continuity between the red/white terminal of the fail-safe relay coupler and the positive battery terminal.
- Remove the ABS fuse and check for continuity between the brown/white lead of the fail-safe relay coupler and the ABS fuse. (See the illustration below.)

Check for continuity between these two points ①.

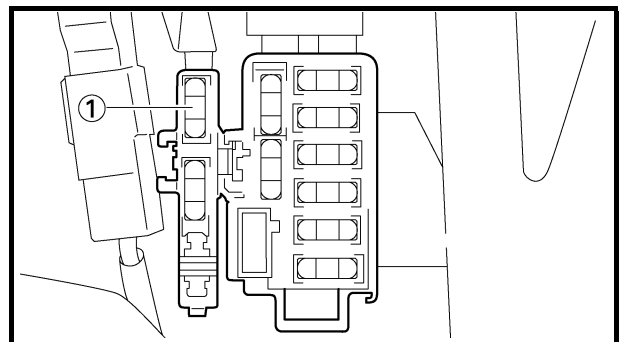
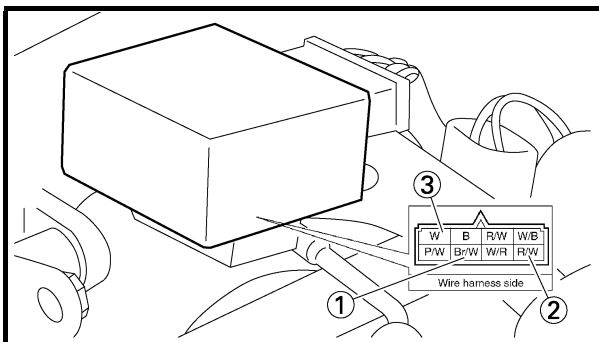

• Malfunction code 32 (Fail-safe relay malfunction is detected.)

Check the following:

- 1) Fail-safe relay
 - Check if the fail-safe relay operates correctly. → P100
- 2) Sub-wire harness (ABS)
 - Disconnect the sub-wire harness (ABS) from the fail-safe relay and the ECU (ABS), and then check the insulation of the fail-safe relay coupler between the red/white ② and white ③ terminals.

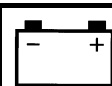

• **Malfunction code 33 (ABS motor operation malfunction is detected. [ABS motor stops and does not rotate.]**)

Check the following:

- 1) ABS motor fuse
 - Check if the ABS motor fuse beside the battery is blown.
- 2) Fail-safe relay
 - Check if the fail-safe relay operates correctly. → P100
- 3) Wire harness and sub-wire harness (ABS)
 - Remove the fail-safe relay and the ABS motor fuse, and then check for continuity between the red/white ② (Refer to “P113–5) wire harness drawing”.) terminal of the sub-wire harness (ABS) and the sub-wire harness (ABS) end (terminal A shown in the illustration) of the ABS motor fuse terminal beside the battery. (Refer to “CIRCUIT DIAGRAM”.)

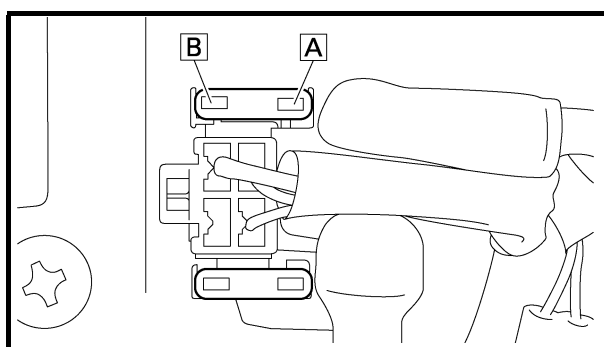

- A Terminal A
- B Terminal B

- Check for continuity between the positive battery terminal and the battery end of the ABS motor fuse terminal (terminal B shown in the above illustration).
 - Remove the ECU (ABS) and the fail-safe relay from the sub-wire harness (ABS), and then check for continuity between the white/black lead terminals and the red/white lead terminals.
- **Malfunction code 34 (ABS motor operation malfunction is detected. [ABS motor keeps rotating and does not stop.]**)

Check the following:

- 1) ABS motor
 - Check if the ABS motor coupler located under the fuel tank is connected properly.
 - Check the ABS motor for continuity. → P59
- 2) Sub-wire harness (ABS)
 - Remove the ABS motor coupler and check for continuity between the black terminal of the ABS motor coupler of the sub-wire harness (ABS) and the negative battery terminal.
 - Remove the ECU (ABS) coupler and check for continuity between the red/white terminal of the ECU (ABS) coupler and the red/white terminal of the ABS motor coupler. → P100
 - Remove the fail-safe relay and check for continuity between the red/white terminal of the ABS motor coupler of the sub-wire harness (ABS) and the positive battery terminal.
- 3) Fail-safe relay
 - Check if the fail-safe relay operates correctly. → P100

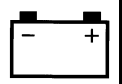

- **Malfunction code 41 (Front wheel does not recover from the locking tendency even though the signal is continuously transmitted from the ECU (ABS) to release the hydraulic pressure [when the battery voltage is normal].)**

Check the following:

- 1) Rotation of the front wheel
 - Check that there is no brake disc drag on the front wheel and make sure it rotates smoothly.
 - Check the front wheel axle for loose bearings and bends, and the brake disc for distortion.
- 2) Brake master cylinder and brake caliper
 - Check that the brake fluid pressure is correctly transmitted to the brake caliper when the brake lever is operated and that the pressure decreases when the lever is released.
- 3) Brake fluid
 - Visually check the brake fluid in the brake master cylinder reservoir and the fluid for water, foreign materials, solidification and contamination.
 - Check for air in the brake hose lines.
- 4) Brake hose lines
 - Check the brake hose lines for kinks and deterioration.

⚠ WARNING

Only use genuine Yamaha parts. Using other brake pipes, hoses and union bolts may close the brake hose lines.

- Check that the connections of the brake hose lines from the brake master cylinder to the hydraulic unit and to the front brake caliper from the hydraulic unit are correct.

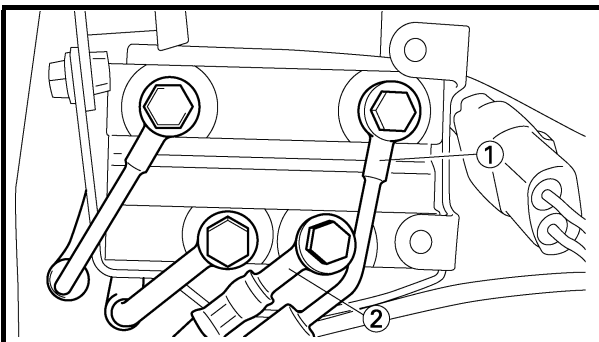

⚠ WARNING

The front brake will not function properly if the connections are reversed.

- **Front brake hose ① inlet: from the front brake master cylinder**
- **Front brake hose ② outlet: to the front brake caliper**

NOTE:

- If the front brake hose inlet and outlet connections are reversed on the hydraulic unit, the brake lever is pulled to full stroke without responding and will be pushed back slowly without pulsating when the final check in P67 is performed.
- If the front and rear brake hose connections are reversed on the hydraulic unit, the pulsating action in the brake lever and brake pedal will be performed in the reverse order when the final check in P66 is performed.

ANTI-LOCK BRAKE SYSTEM (ABS)

ELEC



5) Hydraulic unit solenoid coupler terminal

- Check if the front and rear hydraulic unit solenoid coupler terminals (hydraulic unit and sub-wire harness [ABS]) are reversed.

| | Terminal color | |
|-------|----------------|------------------------|
| | Solenoid | Sub-wire harness (ABS) |
| Front | red, white | white, white/blue |
| Rear | red, green | white, white/green |

6) Hydraulic unit

If the malfunction is not corrected after performing steps 1) to 5), replace the hydraulic unit. Be sure to connect the brake hoses and couplers correctly and securely. Check the hydraulic unit operation. (Refer to “P67 Final check”.)

- **Malfunction code 42 (Rear wheel does not recover from the locking tendency even though the signal is continuously transmitted from the ECU (ABS) to release the hydraulic pressure [when the battery voltage is normal].)**

Check the following:

1) Rotation of the rear wheel

- Check that there is no brake drag on the rear wheel and make sure it rotates smoothly.
- Check for brake disc distortion.

2) Brake master cylinder and brake caliper

- Check that the brake fluid pressure is correctly transmitted to the brake disc when the brake pedal is operated and that the pressure decreases when the pedal is released.

3) Brake fluid

- Visually check the brake fluid in the brake master cylinder reservoir and check the fluid for water, foreign materials, solidification and contamination.
- Check for air in the brake hose lines.

4) Brake hose lines

- Check the brake hose lines for kinks and deterioration (particularly between the hydraulic unit and the rear brake caliper).

⚠ WARNING

Only use genuine Yamaha parts. Using other brake pipes, hoses and union bolts may close the brake hose lines.

ANTI-LOCK BRAKE SYSTEM (ABS)

ELEC

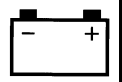

- Check that the connections of the brake hose lines from the brake master cylinder to the hydraulic unit and to the rear brake caliper from the hydraulic unit are correct.

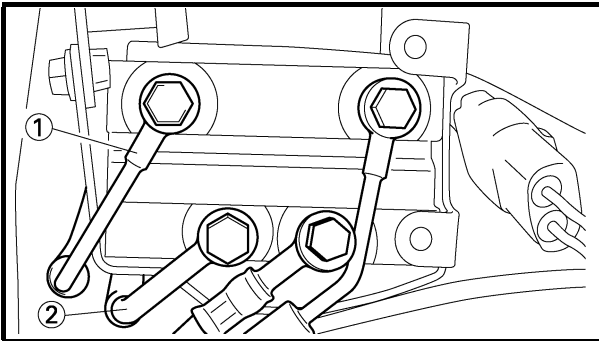

⚠ WARNING

The rear brake will not function properly if the connections are reversed.

- Rear brake hose ① inlet: from the rear brake master cylinder
- Rear brake hose ② outlet: to the rear brake caliper

NOTE:

- If the rear brake hose inlet and outlet connections are reversed on the hydraulic unit, the brake pedal is pressed down to full stroke without responding and will be pushed back slowly without pulsating when the final check is performed.
- If the front and rear brake hose connections are reversed on the hydraulic unit, the pulsating action in the brake lever and brake pedal will be performed in the reverse order when the final check is performed.

5) Hydraulic unit solenoid coupler terminal

- Check if the front and rear hydraulic unit solenoid coupler terminals (hydraulic unit and sub-wire harness [ABS]) are reversed.

| | Terminal color | |
|-------|----------------|------------------------|
| | Solenoid | Sub-wire harness (ABS) |
| Front | red, white | white, white/blue |
| Rear | red, green | white, white/green |

6) Hydraulic unit

If the malfunction is not corrected after performing steps 1) to 5), replace the hydraulic unit. Be sure to connect the brake hose lines and couplers correctly and securely. Check the hydraulic unit operation. (Refer to “P67 Final check”.)

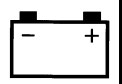

- **Malfunction code 51 (Front wheel does not recover from the locking tendency even though the signal is continuously transmitted from the ECU (ABS) to release the hydraulic pressure [when the battery voltage is low].)**

Check the following:

- 1) Rotation of the front wheel
Refer to "P115 Malfunction code 41".
- 2) Brake master cylinder and brake caliper
Refer to "P115 Malfunction code 41".
- 3) Brake fluid
Refer to "P115 Malfunction code 41".
- 4) Brake hose lines
Refer to "P115 Malfunction code 41".
- 5) Hydraulic unit solenoid coupler terminals
Refer to "P115 Malfunction code 41".
- 6) Hydraulic unit
Refer to "P115 Malfunction code 41".
- 7) Battery voltage
Measure the battery voltage.

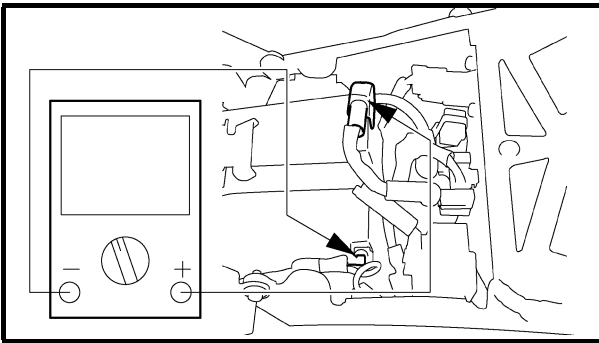

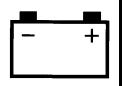

- **Malfunction code 52 (Rear wheel does not recover from the locking tendency even though the signal is continuously transmitted from the ECU (ABS) to release the hydraulic pressure [when the battery voltage is low].)**

Check the following:

- 1) Rotation of the rear wheel
Refer to "P116 Malfunction code 42".
- 2) Brake master cylinder and brake caliper
Refer to "P116 Malfunction code 42".
- 3) Brake fluid
Refer to "P116 Malfunction code 42".
- 4) Brake hose lines
Refer to "P116 Malfunction code 42".
- 5) Hydraulic unit solenoid coupler terminals
Refer to "P116 Malfunction code 42".
- 6) Hydraulic unit
Refer to "P116 Malfunction code 42".
- 7) Battery voltage
Measure the battery voltage.

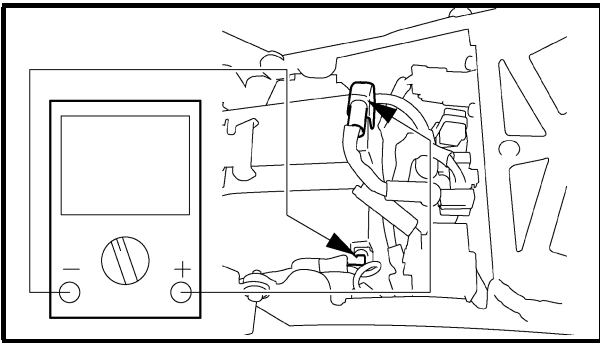

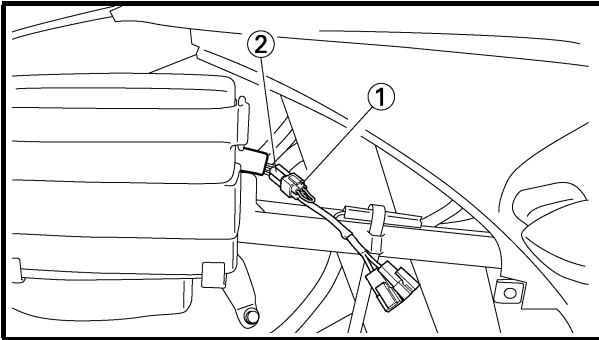
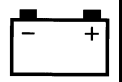

DELETING THE MALFUNCTION CODE

1. Connect the test coupler adapter (1) to the test coupler (2). Refer to "P109".

2. Turn the main switch on.

The multifunction display indicates previously recorded malfunction codes.

NOTE:

The ABS error code is not displayed during the diagnosis of the fuel injection.

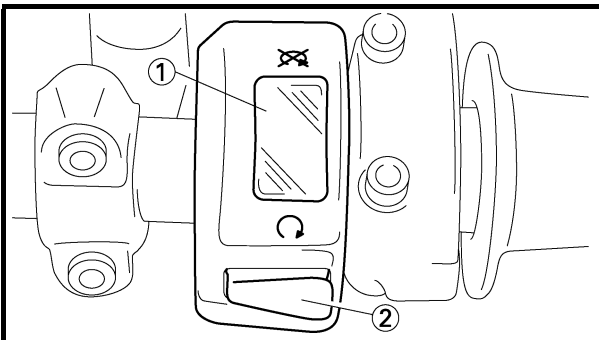

3. Turn the engine stop switch (1) off.

CAUTION:

If the starter switch is pushed without turning the engine stop switch off, it may damage the starting motor gears or other parts, therefore be sure to turn it off.

4. Push the starter switch (2) more than 10 times in 4 seconds to delete the malfunction codes.

NOTE:

If the multifunction codes cannot be cleared, the disconnection of the starter switch monitor leads could be a cause.

5. Turn the main switch off.

ANTI-LOCK BRAKE SYSTEM (ABS)

ELEC

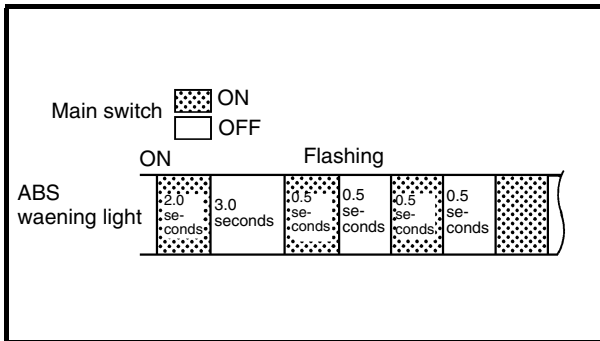
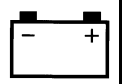

6. Turn the main switch on again.
Check that the ABS warning light goes on for 2 seconds, then goes out for 3 seconds and starts flashing.
7. Turn the main switch off.
8. Disconnect the test coupler adapter from the test coupler, and install the protective cap with the test coupler adapter. Deleting the malfunction code is now finished.

NOTE: _____

Do not forget to install the protective cap.

CAUTION: _____

Since the ECU remains in the memory until the malfunction code is deleted, always delete the malfunction code when the service work is finished.

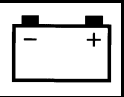

TROUBLESHOOTING

ANTI-LOCK BRAKE SYSTEM (ABS)

ABS TROUBLESHOOTING OUTLINE

This section describes the troubleshooting about ABS in details. Read carefully this service manual before repairing various malfunctions, understand and perform the service.

Electronic control unit (ECU) has the self diagnostic function. When failures occur in the system, the ABS warning light on the meter assembly indicates a malfunction.

Troubleshooting mentioned below describes the cause pursuing and service method according to the indication by the multifunction display. For troubleshooting other than these items, perform by following the normal service method.

⚠ WARNING

When the maintenance or check has been performed on related parts to ABS, be sure to execute the “final check” before delivering the motorcycle to the customer. Refer to “P67 ~ 73”.

ABS Warning Light Goes On and the ABS Condition

- 1) When the ABS warning light keeps going on → It works as a normal brake.
 - Detecting the malfunction by means of the ABS self diagnostic function.
- 2) Light goes on and off at the time of starting → ABS operation is normal.
 - ABS warning light goes on for 2 seconds every time the main switch is turned on and goes off afterward.
- 3) When the ABS warning light flashes → ABS operation is normal.
 - Brake switch is defective or improperly adjusted.
 - Rear wheel is racing.
 - Continuous riding on extremely uneven roads.
 - Disconnection or short-circuit between the meter and ECU (ABS).

Self Diagnosis and Services

ECU has the self diagnostic function. By utilizing this function, quick and secure services are possible.

Previously occurred error phenomenon can be checked since it also installs the memory for storing malfunction history.

“In case malfunctions are detected”

It is disabled to call the malfunction code by using the ABS warning light since the ABS warning light already goes on. Connect the test coupler adapter to the test coupler, connect a pocket tester to the terminal of light green lead and check by its pointing needle movement. (Refer to “P108”)

“In case any malfunctions are not detected”

The multifunction display indicates all the malfunction codes recorded in the ECU (ABS). You can check it by using a pocket tester. Note everything if more than two items of malfunction codes are recorded.



“Deleting the malfunction code”

When the malfunction service is finished, check the normal operation of motorcycle then delete the malfunction code (Refer to “P120”). By deleting the malfunction code memory, it is possible to pursue the cause correctly if the next defective phenomenon occurred.

Self diagnosis by ECU

ECU performs the static check for whole system when the main switch is turned on. It is also possible to check the malfunction while riding. It is possible to check the recorded malfunction data by using a pocket tester or the multifunction display of meter by setting the ECU to the self diagnostic mode since all malfunctions which has been once detected are recorded.

Differences Between the Normal Handling and Services On a Vehicle

- Care should be taken not to damage components by shocks and pulling too much since the ABS components are precisely adjusted.
- ECU, HU, Wheel sensors and fail-safe relay cannot be disassembled.
- Malfunction history in ECU is recorded. Delete it when the service is finished. (This is because the past malfunction contents will be redundantly displayed when the same malfunction occurred again.)

BASIC INSTRUCTION FOR TROUBLESHOOTING

WARNING

- Execute the troubleshooting on each malfunction from [A] to [D] in sequence.
- Use the sufficiently charged regular batteries only.

[A] Malfunction check by the ABS warning light

[B] Detail check of malfunction

Results by self diagnosis are displayed by the multifunction display or a pocket tester according to the ECU's operation.

[C] Supposing the malfunction cause and position

Find the malfunction cause by reasoning the place and situation where it occurred.

[D] ABS system services

Execute the final check after disassembly and assembly.

WARNING

Perform the troubleshooting [A] → [B] → [C] → [D] in order. Be sure to follow the order since it results in the wrong diagnosis if the order is differently taken or omitted.

BASIC PROCESS FOR TROUBLESHOOTING

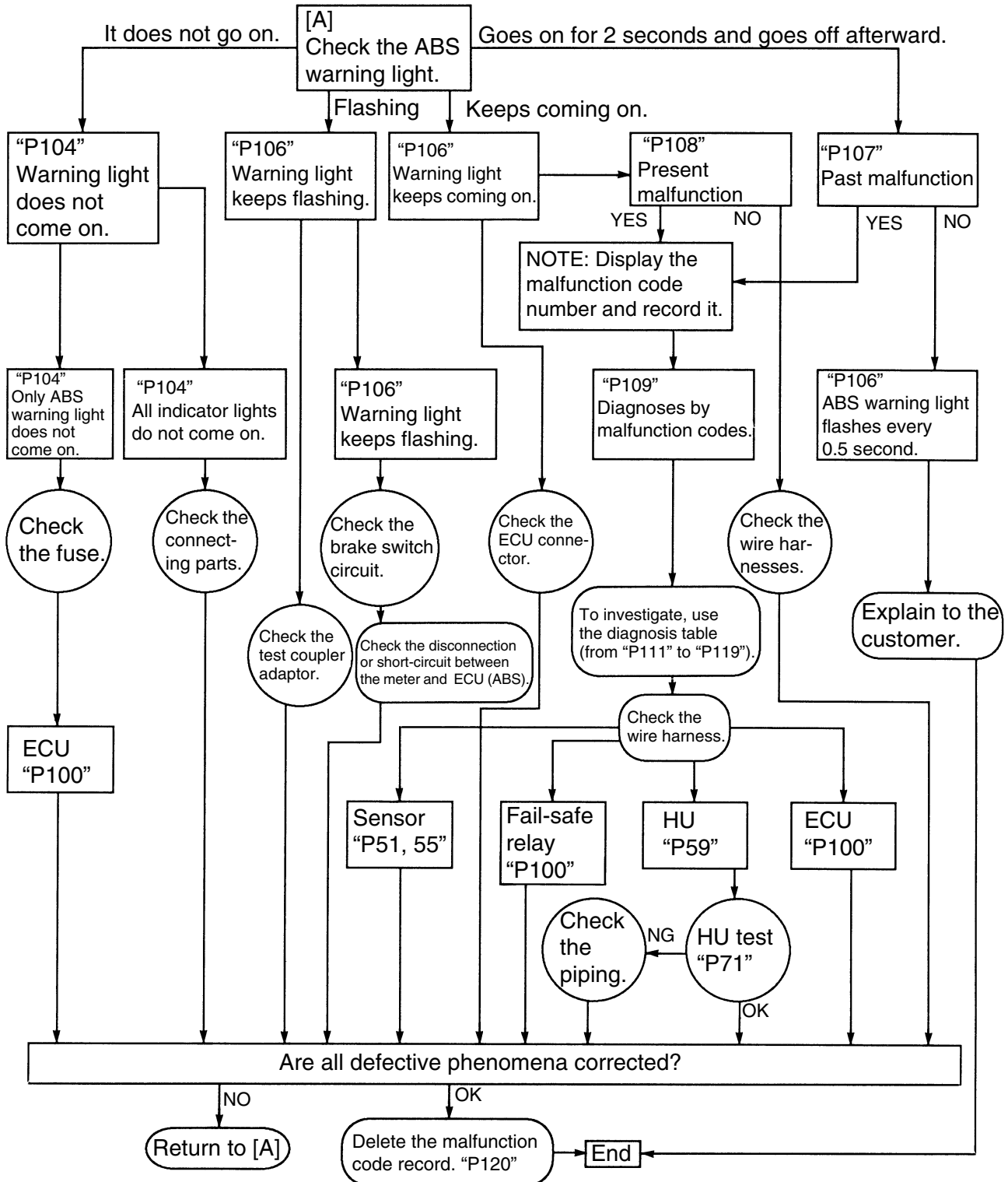

NOTE: Do not delete the malfunction code during the troubleshooting procedures. Be sure to delete it when the service is finished.

WARNING

Always execute the "final check" when the components related to ABS are checked and serviced.



TROUBLESHOOTING AT THE ABS WARNING LIGHT

When the main switch is turned "ON". (Engine does not start.)

ONLY THE ABS WARNING LIGHT DOES NOT COME ON.

- Blown, damaged, or incorrect fuse (ABS fuse)
- Defective connection of the ABS harness and the wire harness
- Defective connection of the ABS harness and the electronic control unit (ECU)
- ABS harness is disconnected
- ABS warning light bulb is burnt out or the bulb contact is defective
- ECU defective

ALL INDICATORS DO NOT COME ON.

- Battery defective
- Blown, damaged, or incorrect fuse (Main fuse)
- Defective connection of the main fuse coupler
- Defective connection of the wire harness and the ABS harness
- Defective connection of the main switch coupler
- Defective connection of the meter coupler

ABS WARNING LIGHT CONTINUES TO FLASHES.

- Brake light switch (Front or rear) is defective
- Brake light switch coupler has come off
- Wire harness is disconnected
- Blown, damaged, or incorrect fuse (Main fuse)
- Defective connection of the ABS harness and the wire harness couplers
- Disconnection or short-circuit between the meter and ECU (ABS).

ABS WARNING LIGHT FLASHES EVERY 0.5 SECONDS.

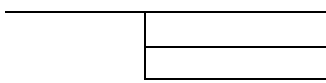
- Voltage drop (Less than 10 V)  Battery
Rectifier/regulator
AC magneto

- Strong radio waves or static electricity

ABS WARNING LIGHT CONTINUES TO COME ON.

- Defective connection of the wheel sensor (Front or rear) circuit
- Wheel sensor lead (Front or rear) coupler has come off
- Wheel sensor lead (Front or rear) or the coil is disconnected
- Sensor circuit of the ABS harness is disconnected
- ECU coupler terminal has come off

TDM900A(T) 2005 WIRING DIAGRAM

- ① A.C. magneto
- ② Rectifier/regulator
- ③ Fuse (fuel injection system)
- ④ Fuse (ABS)
- ⑤ Fuse (main)
- ⑥ Fuse (ABS motor)
- ⑦ Starter relay
- ⑧ Starter motor
- ⑨ Battery
- ⑩ Main switch
- ⑪ Alarm
- ⑫ Immobilizer unit
- ⑬ Fuse (backup)
- ⑭ Starting circuit cut-off relay
- ⑮ Sidestand switch
- ⑯ Neutral switch
- ⑰ Cylinder identification sensor
- ⑱ Crankshaft position sensor
- ⑲ Throttle position sensor
- ⑳ Intake air pressure sensor
- ㉑ Atmospheric pressure sensor
- ㉒ Intake air temperature sensor
- ㉓ Coolant temperature sensor
- ㉔ Lean angle cut-off switch
- ㉕ O₂ sensor
- ㉖ ECU
- ㉗ Injector #1
- ㉘ Injector #2
- ㉙ Air cut-off valve
- ㉚ Intake solenoid
- ㉛ Speed sensor
- ㉜ Ignition coil #1
- ㉝ Ignition coil #2
- ㉞ Spark plug
- ㉟ ABS test terminal
- ㊱ Fuel pump
- ㊲ ECU (ABS)
- ㊳ ABS wire lead
- ㊴ Fail safe relay
- ㊵ Hydraulic unit
- ㊶ Front wheel sensor
- ㊷ Rear wheel sensor
- ㊸ Meter assembly
- ㊹ Oil level warning light
- ㊺ Neutral indicator light
- ㊻ Multi-function meter
- ㊼ Engine trouble warning light
- ㊽ Immobilizer system indicator light
- ㊾ High beam indicator light
- ㊿ Turn signal indicator light
- 1 Meter light
- 2 ABS warning light
- 3 Oil level switch
- 4 Turn signal relay
- 5 Right handlebar switch
- 6 Front brake light switch
- 7 Engine stop switch
- 8 Start switch
- 9 Left handlebar switch
- 0 Horn switch
- 1 Pass switch
- 2 Dimmer switch

- 3 Hazard switch
- 4 Turn signal switch
- 5 Clutch switch
- 6 Horn
- 7 Rear turn signal light (left)
- 8 Rear turn signal light (right)
- 9 Front turn signal light (left)
- 0 Front turn signal light (right)
- 1 Headlight relay
- 2 Headlight
- 3 Rear brake light switch
- 4 Tail/brake light
- 5 Auxiliary light
- 6 Fuse (ignition)
- 7 Fuse (head)
- 8 Fuse (hazard)
- 9 Fuse (signal)
- 0 Fuse (radiator fan motor)
- 1 Radiator fan motor relay
- 2 Radiator fan motor

COLOR CODE

| | | | |
|--------------|--------------|---------------|--------------|
| B | Black | G/R . . . | Green/Red |
| Br | Brown | G/W . . . | Green/White |
| Ch | Chocolate | G/Y | Green/Yellow |
| Dg | Dark green | Gy/G . . . | Gray/Green |
| G | Green | Gy/R . . . | Gray/Red |
| Gy | Gray | L/B | Blue/Black |
| L | Blue | L/G | Blue/Green |
| Lg | Light green | L/R | Blue/Red |
| O | Orange | L/W | Blue/White |
| P | Pink | L/Y | Blue/Yellow |
| R | Red | P/W | Pink/White |
| Sb | Sky blue | R/B | Red/Black |
| W | White | R/G | Red/Green |
| Y | Yellow | R/L | Red/Blue |
| B/L | Black/Blue | R/W | Red/White |
| B/W | Black/White | R/Y | Red/Yellow |
| B/Y | Black/Yellow | W/B | White/Black |
| Br/B | Brown/Black | W/G | White/Green |
| Br/G | Brown/Green | W/L | White/Blue |
| Br/L | Brown/Blue | W/R | White/Red |
| Br/R | Brown/Red | W/Y | White/Yellow |
| Br/W | Brown/White | Y/B | Yellow/Black |
| G/B | Green/Black | Y/G | Yellow/Green |
| G/L | Green/Blue | Y/L | Yellow/Blue |



YAMAHA MOTOR CO., LTD.

2500 SHINGAI IWATA SHIZUOKA JAPAN

TDM900A(T) 2005 WIRING DIAGRAM

