

## FOREWORD

This manual contains an introductory description on the SUZUKI GSX1400 and procedures for its inspection/service and overhaul of its main components.

Other information considered as generally known is not included.

Read the GENERAL INFORMATION section to familiarize yourself with the motorcycle and its maintenance. Use this section as well as other sections to use as a guide for proper inspection and service. This manual will help you know the motorcycle better so that you can assure your customers of fast and reliable service.

- \* This manual has been prepared on the basis of the latest specifications at the time of publication. If modifications have been made since then, differences may exist between the content of this manual and the actual motorcycle.
- \* Illustrations in this manual are used to show the basic principles of operation and work procedures. They may not represent the actual motorcycle exactly in detail.
- \* This manual is written for persons who have enough knowledge, skills and tools, including special tools, for servicing SUZUKI motorcycles. If you do not have the proper knowledge and tools, ask your authorized SUZUKI motorcycle dealer to help you.

### **▲ WARNING**

Inexperienced mechanics or mechanics without the proper tools and equipment may not be able to properly perform the services described in this manual. Improper repair may result in injury to the mechanic and may render the motorcycle unsafe for the rider and passenger.

**SUZUKI MOTOR CORPORATION**

Overseas Service Department

## GROUP INDEX

<b>GENERAL INFORMATION</b>	<b>1</b>
<b>PERIODIC MAINTENANCE</b>	<b>2</b>
<b>ENGINE</b>	<b>3</b>
<b>FI SYSTEM</b>	<b>4</b>
<b>OIL COOLING AND LUBRICATION SYSTEM</b>	<b>5</b>
<b>CHASSIS</b>	<b>6</b>
<b>ELECTRICAL SYSTEM</b>	<b>7</b>
<b>SERVICING INFORMATION</b>	<b>8</b>

## HOW TO USE THIS MANUAL TO LOCATE WHAT YOU ARE LOOKING FOR:

1. The text of this manual is divided into sections.
2. The section titles are listed in the GROUP INDEX.
3. Holding the manual as shown at the right will allow you to find the first page of the section easily.
4. The contents are listed on the first page of each section to help find the item and page you need.

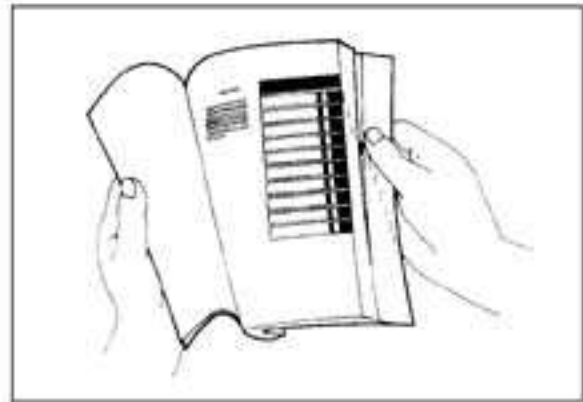

## COMPONENT PARTS AND WORK TO BE DONE





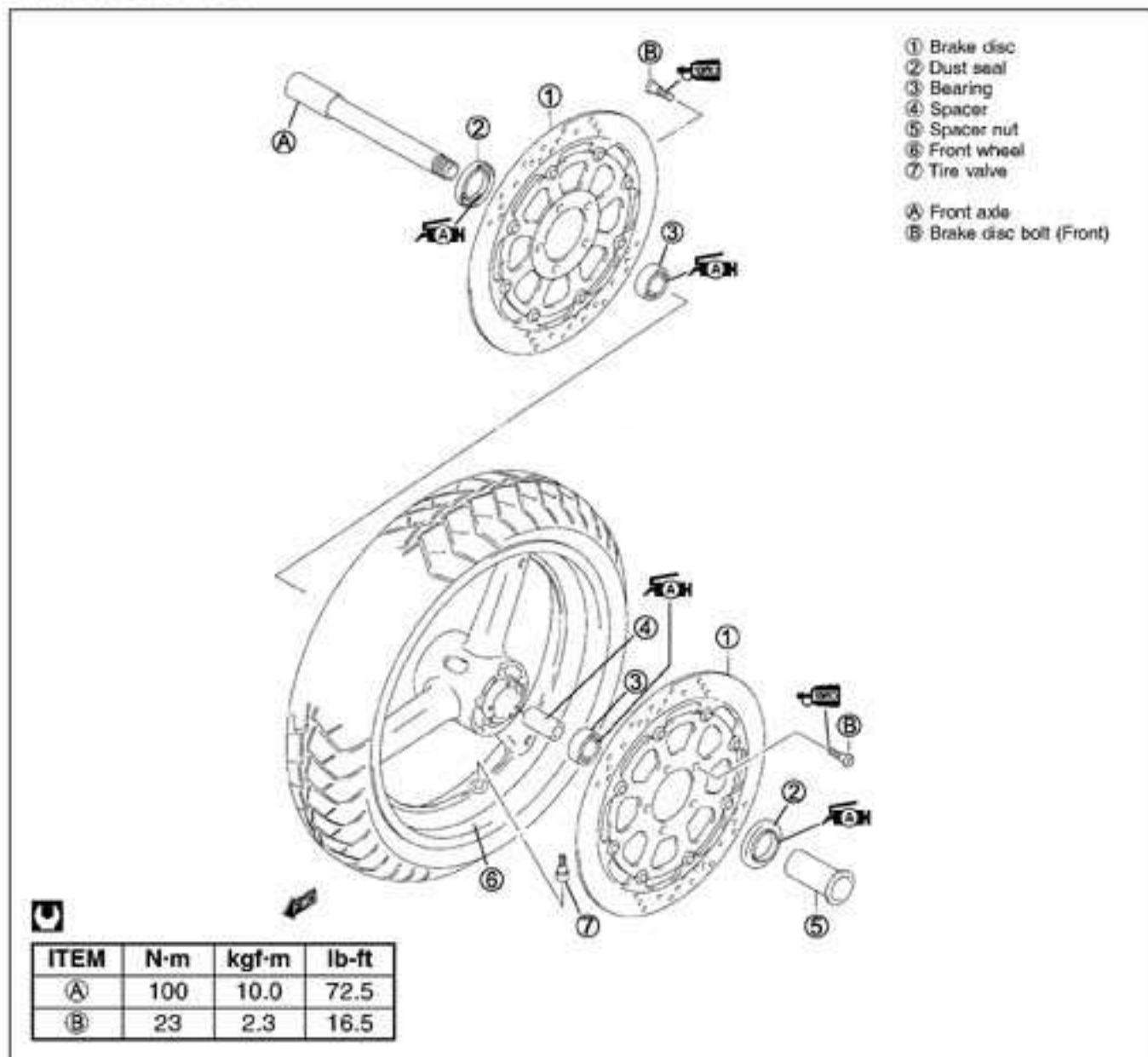













Under the name of each system or unit, is its exploded view. Work instructions and other service information such as the tightening torque, lubricating points and locking agent points, are provided.

Example: Front wheel



## SYMBOL

Listed in the table below are the symbols indicating instructions and other information necessary for servicing. The meaning of each symbol is also included in the table.

SYMBOL	DEFINITION	SYMBOL	DEFINITION
	Torque control required. Data beside it indicates specified torque.		Apply THREAD LOCK SUPER "1360". 99000-32130
	Apply oil. Use engine oil unless otherwise specified.		Use fork oil. 99000-99044-L01
	Apply molybdenum oil solution. (Mixture of engine oil and SUZUKI MOLY PASTE in a ratio of 1:1)		Apply or use brake fluid.
	Apply SUZUKI SUPER GREASE "A". 99000-25010		Measure in voltage range.
	Apply SUZUKI MOLY PASTE. 99000-25140		Measure in current range.
	Apply SUZUKI BOND "1207B". 99000-31140		Measure in diode test range.
	Apply SUZUKI BOND "1216B". 99000-31230		Measure in continuity test range.
	Apply THREAD LOCK SUPER "1303". 99000-32030		Use special tool.
	Apply THREAD LOCK SUPER "1322". 99000-32110		Indication of service data.
	Apply THREAD LOCK "1342". 99000-32050		

## ABBREVIATIONS MAY BE USED IN THIS MANUAL

<b>A</b>		<b>E</b>	
ABDC	: After Bottom Dead Center	ECM	: Engine Control Module Engine Control Unit (ECU) (FI Control Unit)
AC	: Alternating Current	EOT Sensor	: Engine Oil Temperature Sensor (EOTS), Oil Temp. Sensor (OTS)
ACL	: Air Cleaner, Air Cleaner Box	EVAP	: Evaporative Emission
API	: American Petroleum Institute	EVAP Canister	: Evaporative Emission Canister (Canister)
ATDC	: After Top Dead Center		
ATM Pressure	: Atmospheric Pressure Atmospheric Pressure Sensor (APS, AP Sensor)		
A/F	: Air Fuel Mixture		
<b>B</b>		<b>F</b>	
BBDC	: Before Bottom Dead Center	FI	: Fuel Injection, Fuel Injector
BTDC	: Before Top Dead Center	FP	: Fuel Pump
B+	: Battery Positive Voltage	FPR	: Fuel Pressure Regulator
		FP Relay	: Fuel Pump Relay
<b>C</b>		<b>G</b>	
CKP Sensor	: Crankshaft Position Sensor (CKPS)	GEN	: Generator
CKT	: Circuit	GND	: Ground
CLP Switch	: Clutch Lever Position Switch (Clutch Switch)	GP Switch	: Gear Position Switch
CMP Sensor	: Camshaft Position Sensor (CMPS)		
CO	: Carbon Monoxide	<b>H</b>	
CPU	: Central Processing Unit	HC	: Hydrocarbons
<b>D</b>		<b>I</b>	
DC	: Direct Current	IAP Sensor	: Intake Air Pressure Sensor (IAPS)
DMC	: Dealer Mode Coupler	IAT Sensor	: Intake Air Temperature Sensor (IATS)
DOHC	: Double Over Head Camshaft	IG	: Ignition
DRL	: Daytime Running Light	<b>L</b>	
		LCD	: Liquid Crystal Display
		LED	: Light Emitting Diode (Malfunction Indicator Lamp)
		LH	: Left Hand



**M**

MAL-Code	: Malfunction Code (Diagnostic Code)
Max	: Maximum
MIL	: Malfunction Indicator Lamp (LED)
Min	: Minimum

**N**

NOx	: Nitrogen Oxides
-----	-------------------

**O**

OHC	: Over Head Camshaft
OPS	: Oil Pressure Switch

**P**

PCV	: Positive Crankcase Ventilation (Crankcase Breather)
-----	--

**R**

RH	: Right Hand
ROM	: Read Only Memory

**S**

SAE	: Society of Automotive Engineers
STC System	: Secondary Throttle Control System (STCS)
STP Sensor	: Secondary Throttle Position Sensor (STPS)
ST Valve	: Secondary Throttle Valve (STV)
STV Actuator	: Secondary Throttle Valve Actuator (STVA)

**T**

TO Sensor	: Tip Over Sensor (TOS)
TP Sensor	: Throttle Position Sensor (TPS)

# GENERAL INFORMATION

**1**

## CONTENTS

<b>WARNING/CAUTION/NOTE .....</b>	<b>1- 2</b>
<b>GENERAL PRECAUTIONS .....</b>	<b>1- 2</b>
<b>SUZUKI GSX1400K2 (2002-MODEL) .....</b>	<b>1- 4</b>
<b>SERIAL NUMBER LOCATION .....</b>	<b>1- 4</b>
<b>FUEL AND OIL RECOMMENDATION .....</b>	<b>1- 5</b>
<b>FUEL .....</b>	<b>1- 5</b>
<b>ENGINE OIL .....</b>	<b>1- 5</b>
<b>BRAKE FLUID .....</b>	<b>1- 5</b>
<b>FRONT FORK OIL .....</b>	<b>1- 5</b>
<b>BREAK-IN PROCEDURES .....</b>	<b>1- 6</b>
<b>CYLINDER IDENTIFICATION .....</b>	<b>1- 6</b>
<b>INFORMATION LABELS .....</b>	<b>1- 7</b>
<b>SPECIFICATIONS .....</b>	<b>1- 8</b>
<b>COUNTRY AND AREA CODES .....</b>	<b>1-10</b>

## WARNING/CAUTION/NOTE

Please read this manual and follow its instructions carefully. To emphasize special information, the symbol and the words WARNING, CAUTION and NOTE have special meanings. Pay special attention to the messages highlighted by these signal words.

### **▲ WARNING**

Indicates a potential hazard that could result in death or injury.

### **CAUTION**

Indicates a potential hazard that could result in motorcycle damage.

### *NOTE:*

*Indicates special information to make maintenance easier or instructions clearer.*

Please note, however, that the warnings and cautions contained in this manual cannot possibly cover all potential hazards relating to the servicing, or lack of servicing, of the motorcycle. In addition to the WARNINGS and CAUTIONS stated, you must use good judgement and basic mechanical safety principles. If you are unsure about how to perform a particular service operation, ask a more experienced mechanic for advice.

## GENERAL PRECAUTIONS

### **▲ WARNING**

- \* Proper service and repair procedures are important for the safety of the service mechanic and the safety and reliability of the motorcycle.
- \* When 2 or more persons work together, pay attention to the safety of each other.
- \* When it is necessary to run the engine indoors, make sure that exhaust gas is forced outdoors.
- \* When working with toxic or flammable materials, make sure that the area you work in is well-ventilated and that you follow all of the material manufacturer's instructions.
- \* Never use gasoline as a cleaning solvent.
- \* To avoid getting burned, do not touch the engine, engine oil, radiator and exhaust system until they have cooled.
- \* After servicing the fuel, oil, engine coolant, exhaust or brake systems, check all lines and fittings related to the system for leaks.

**CAUTION**

- If parts replacement is necessary, replace the parts with Suzuki Genuine Parts or their equivalent.
  - When removing parts that are to be reused, keep them arranged in an orderly manner so that they may be reinstalled in the proper order.
  - Be sure to use special tools when instructed.
  - Make sure that all parts used in reassembly are clean. Lubricate them when specified.
  - Use the specified lubricant, bond, or sealant.
  - When removing the battery, disconnect the negative cable first and then the positive cable.
  - When reconnecting the battery, connect the positive cable first and then the negative cable, and cover the positive terminal with the terminal cover.
  - When performing service to electrical parts, disconnect the battery negative cable unless the service procedure requires the battery power.
  - When tightening cylinder head and crankcase bolts and nuts, tighten the larger sizes first. Always tighten the bolts and nuts diagonally from the inside working out and to the specified tightening torque.
  - Whenever you remove oil seals, gaskets, packing, O-rings, locking washers, self-locking nuts, cotter pins, circlips, and certain other parts as specified, be sure to replace them with new ones. Also, before installing these new parts, be sure to remove any left over material from the mating surfaces.
  - Never reuse a circlip. When installing a new circlip, take care not to expand the end gap larger than required to slip the circlip over the shaft. After installing a circlip, always ensure that it is completely seated in its groove and securely fitted.
  - Use a torque wrench to tighten fasteners to the specified torque. Wipe off grease and oil if a thread is smeared with them.
  - After reassembling, check parts for tightness and proper operation.
- 
- To protect the environment, do not unlawfully dispose of used motor oil, engine coolant and other fluids: batteries, and tires.
  - To protect the earth's natural resources, properly dispose of used motorcycles and parts.

## SUZUKI GSX1400K2 (2002-MODEL)



RIGHT SIDE



LEFT SIDE

\* Difference between photograph and actual motorcycle depends on the markets.

### SERIAL NUMBER LOCATION

The frame serial number or V.I.N. (Vehicle Identification Number) (A) is stamped on the right side of the steering head pipe. The engine serial number (B) is located on the rear side of the crankcase. These numbers are required especially for registering the machine and ordering spare parts.

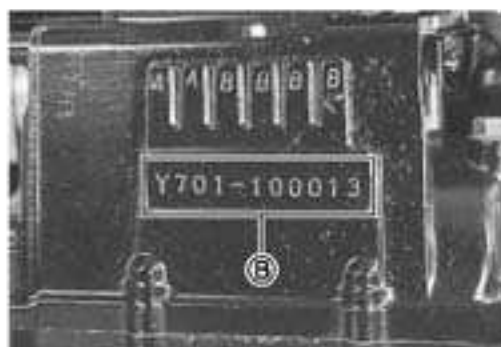

## FUEL AND OIL RECOMMENDATION

### FUEL

Gasoline used should be graded 91 octane (Research Method) or higher. An unleaded gasoline is recommended.

### ENGINE OIL

Use a premium quality 4-stroke motor oil to ensure longer service life of your motorcycle. Use only oils which are rated SF or SG under the API service classification.

The recommended viscosity is SAE 10W-40. If an SAE 10W-40 motor oil is not available, select an alternative according to the following chart.

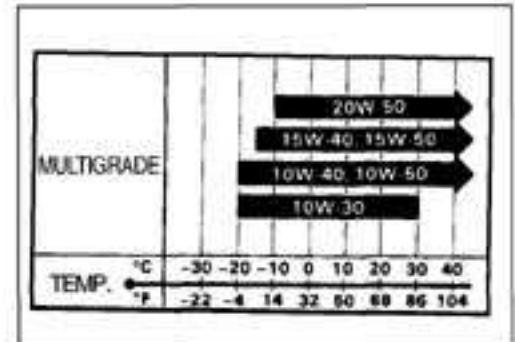

### BRAKE FLUID

Use DOT4 brake fluid.

#### **▲ WARNING**

Since the brake system of this motorcycle is filled with a glycol-based brake fluid by the manufacturer, do not use or mix different types of fluid such as silicone-based and petroleum-based fluid for refilling the system, otherwise serious damage will result.

Do not use any brake fluid taken from old or used or unsealed containers.

Never re-use brake fluid left over from a previous servicing, which has been stored for a long period.

### FRONT FORK OIL

Use fork oil L01 or an equivalent fork oil.

## BREAK-IN PROCEDURES

During manufacture only the best possible materials are used and all machined parts are finished to a very high standard but it is still necessary to allow the moving parts to "BREAK-IN" before subjecting the engine to maximum stresses. The future performance and reliability of the engine depends on the care and restraint exercised during its early life. The general rules are as follows.

- Keep to these break-in procedures:

**Initial 800 km ( 500 miles): Below 4 500 r/min**

**Up to 1 600 km (1 000 miles): Below 6 700 r/min**

**Over to 1 600 km (1 000 miles): Below 9 000 r/min**

- Upon reaching an odometer reading of 1 600 km (1 000 miles) you can subject the motorcycle to full throttle operation. However, do not exceed 9 000 r/min at any time.

## CYLINDER IDENTIFICATION

The four cylinders of this engine are identified as No.1, No.2, No.3 and No.4 cylinder, as counted from left to right (as viewed by the rider on the seat).



## INFORMATION LABELS

	GSX1400	GSX1400UD
① Noise label	○ For E-24	
② Fuel caution label	○ For E-02, 24	
③ Tire pressure label	○	○
④ Warning safety label	○	○
⑤ ID plate	○ For E-02, 19, 24	○
⑥ Loading capacity	○	○

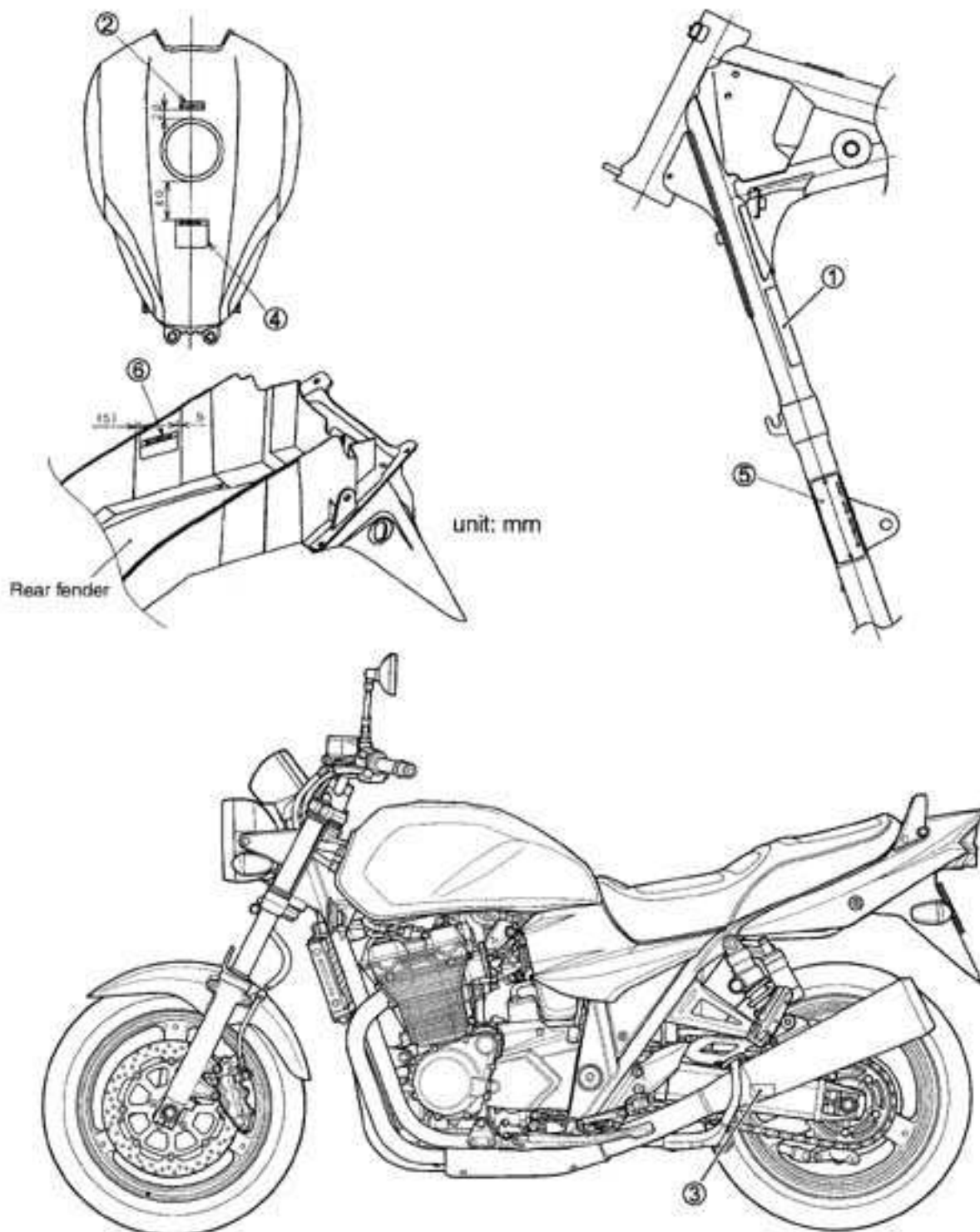

## SPECIFICATIONS

### DIMENSIONS AND DRY MASS

Overall length .....	2 160 mm (85.0 in)
Overall width .....	810 mm (31.9 in)
Overall height .....	1 140 mm (44.9 in)
Wheelbase .....	1 520 mm (59.8 in)
Ground clearance .....	130 mm (5.1 in)
Seat height .....	790 mm (31.1 in)
Dry mass .....	228 kg (502 lbs)

### ENGINE

Type .....	Four-stroke, air-cooled with SACS, DOHC
Number of cylinders .....	4
Bore .....	81.0 mm (3.189 in)
Stroke .....	68.0 mm (2.677 in)
Piston displacement .....	1 402 cm <sup>3</sup> (85.5 cu. in)
Compression ratio .....	9.5 : 1
Fuel system .....	Fuel injection system
Air cleaner .....	Non-woven fabric element
Starter system .....	Electric
Lubrication system .....	Wet sump
Idle speed .....	1 100 ± 100 r/min

### TRANSMISSION

Clutch .....	Wet multi-plate type
Transmission .....	6-speed constant mesh
Gearshift pattern .....	1-down, 5-up
Primary reduction ratio .....	1.509 (83/55)
Gear ratios, Low .....	2.916 (35/12)
2nd .....	1.937 (31/16)
3rd .....	1.526 (29/19)
4th .....	1.285 (27/21)
5th .....	1.136 (25/22)
Top .....	1.000 (24/24)
Final reduction ratio .....	2.277 (41/18)
Drive chain .....	RK GB50GSVZ3, 116 links

**CHASSIS**

Front suspension .....	Telescopic, coil spring, oil damped
Rear suspension .....	Swingarm, coil spring, oil damped
Front suspension stroke .....	130 mm (5.1 in)
Rear wheel travel .....	123 mm (4.7 in)
Caster .....	26°
Trail .....	105 mm (4.1 in)
Steering angle .....	37° (right and left)
Turning radius .....	2.8 m (9.2 ft)
Front brake .....	Disc brake, twin
Rear brake .....	Disc brake
Front tire size .....	120/70 ZR17 (58 W), tubeless
Rear tire size .....	190/50 ZR17 (73 W), tubeless

**ELECTRICAL**

Ignition type .....	Electronic ignition (Transistorized)
Ignition timing .....	7° B.T.D.C. at 1 100 r/min
Spark plug .....	NGK CR8EK DENSO U24ETR
Battery .....	12 V 43.2 kC (12 Ah)/10 HR
Generator .....	Three-phase A.C. generator
Main fuse .....	30 A
Fuse .....	10/10/15/15/10/10 A
Headlight .....	12 V 60/55 W (H4)
Position light .....	12 V 5 W ..... Except E-24
Turn signal light .....	12 V 21 W
Brake light/Taillight .....	12 V 21/5 W × 2
Speedometer light .....	LED
Tachometer light .....	LED
Turn signal indicator light .....	LED
Neutral indicator light .....	LED
High beam indicator light .....	LED
Oil pressure indicator light .....	LED
Fuel injection warning light .....	LED

**CAPACITIES**

Fuel tank, including reserve .....	22 L (5.8/4.8 US/imp gal)
Engine oil, oil change .....	4 200 ml (4.4/3.7 US/imp qt)
with filter change .....	4 800 ml (5.1/4.2 US/imp qt)
overhaul .....	5 700 ml (6.0/5.0 US/imp qt)
Front fork oil (each leg) .....	648 ml (21.9/22.8 US/imp oz)

These specifications are subject to change without notice.

**COUNTRY AND AREA CODES**

The following codes stand for the applicable country(-ies) and area(-s).

<b>MODEL</b>	<b>CODE</b>	<b>COUNTRY or AREA</b>
GSX1400	E-02	U.K.
	E-19	EU
	E-24	Australia
GSX1400UD	E-19	EU

**PERIODIC MAINTENANCE****CONTENTS**

<b>PERIODIC MAINTENANCE SCHEDULE</b> .....	<b>2- 2</b>
<b>PERIODIC MAINTENANCE CHART</b> .....	<b>2- 2</b>
<b>LUBRICATION POINTS</b> .....	<b>2- 3</b>
<b>MAINTENANCE AND TUNE-UP PROCEDURES</b> .....	<b>2- 4</b>
<b>AIR CLEANER</b> .....	<b>2- 4</b>
<b>SPARK PLUG</b> .....	<b>2- 5</b>
<b>VALVE CLEARANCE</b> .....	<b>2- 6</b>
<b>ENGINE OIL AND OIL FILTER</b> .....	<b>2-13</b>
<b>FUEL HOSE</b> .....	<b>2-14</b>
<b>ENGINE IDLE SPEED</b> .....	<b>2-14</b>
<b>THROTTLE VALVE SYNCHRONIZATION</b> .....	<b>2-15</b>
<b>THROTTLE CABLE PLAY</b> .....	<b>2-15</b>
<b>CLUTCH</b> .....	<b>2-16</b>
<b>DRIVE CHAIN</b> .....	<b>2-17</b>
<b>BRAKE</b> .....	<b>2-19</b>
<b>TIRE</b> .....	<b>2-22</b>
<b>STEERING</b> .....	<b>2-23</b>
<b>FRONT FORK</b> .....	<b>2-24</b>
<b>REAR SUSPENSION</b> .....	<b>2-24</b>
<b>EXHAUST PIPE BOLT AND NUT</b> .....	<b>2-24</b>
<b>CHASSIS BOLT AND NUT</b> .....	<b>2-25</b>
<b>COMPRESSION PRESSURE CHECK</b> .....	<b>2-27</b>
<b>OIL PRESSURE CHECK</b> .....	<b>2-28</b>

## PERIODIC MAINTENANCE SCHEDULE

The chart below lists the recommended intervals for all the required periodic service work necessary to keep the motorcycle operating at peak performance and economy. Maintenance intervals are expressed in terms of kilometer, miles and months, and are dependant on whichever comes first.

### NOTES:

More frequent servicing may be performed on motorcycles that are used under severe conditions.

### PERIODIC MAINTENANCE CHART

Item	Interval		1 000	6 000	12 000	18 000	24 000
	km						
	miles		600	4 000	7 500	11 000	15 000
	months		1	6	12	18	24
Air cleaner element			-	I	I	R	I
Spark plugs			-	I	R	I	R
Valve clearance			-	-	-	-	I
Engine oil			R	R	R	R	R
Engine oil filter			R	-	-	R	-
Fuel line			-	I	I	I	I
			Replace fuel hose every 4 years.				
Idle speed			I	I	I	I	I
Throttle valve synchronization			-	-	I	-	I
PAIR (air supply) system			-	-	I	-	I
Throttle cable play			I	I	I	I	I
Clutch hose			-	I	I	I	I
			Replace every 4 years.				
Clutch fluid			-	I	I	I	I
			Replace every 2 years.				
Drive chain			I	I	I	I	I
			Clean and lubricate every 1 000 km (600 miles).				
Brakes			I	I	I	I	I
Brake hoses			-	I	I	I	I
			Replace every 4 years.				
Brake fluid			-	I	I	I	I
			Replace every 2 years.				
Tires			-	I	I	I	I
Steering			I	-	I	-	I
Front forks			-	-	I	-	I
Rear suspension			-	-	I	-	I
Exhaust pipe bolts and muffler bolt and nut			T	-	T	-	T
Chassis bolts and nuts			T	T	T	T	T

I = Inspect and adjust, clean, lubricate or replace as necessary.

R = Replace

T = Tighten

## LUBRICATION POINTS

Proper lubrication is important for smooth operation and long life of each working part of the motorcycle. Major lubrication points are indicated below.

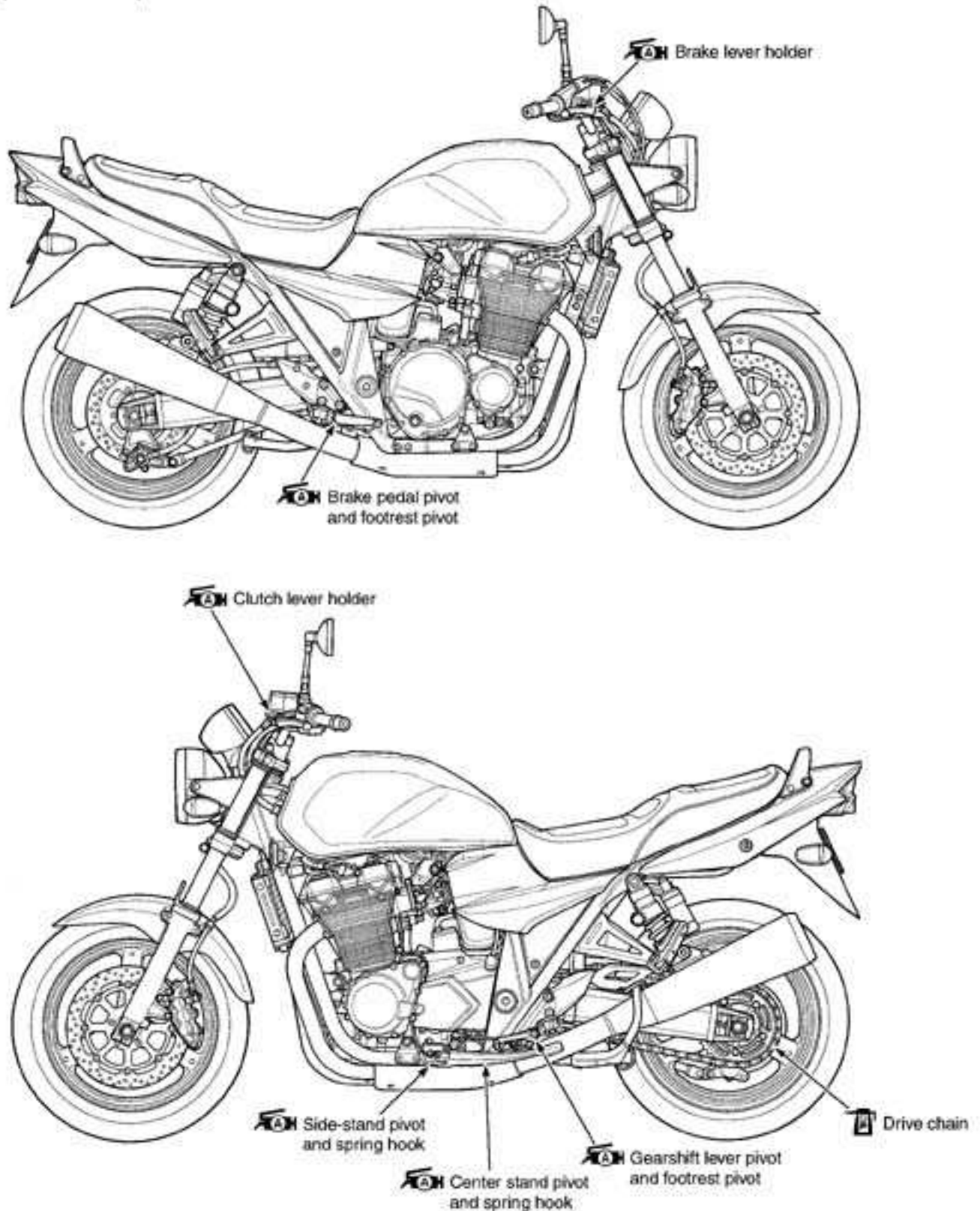

### NOTE:

- \* Before lubricating each part, clean off any rusty spots and wipe off any grease, oil, dirt or grime.
- \* Lubricate exposed parts which are subject to rust, with a rust preventative spray, especially whenever the motorcycle has been operated under wet or rainy conditions.



## MAINTENANCE AND TUNE-UP PROCEDURES

This section describes the servicing procedures for each item mentioned in the Periodic Maintenance chart.

### AIR CLEANER

- Remove the fuel tank.
- Remove the fuel tank bracket.



- Remove the air cleaner element by removing the screws.



- Carefully use air hose to blow the dust from the cleaner element.

#### CAUTION

Always use air pressure on the outside of the air cleaner element. If air pressure is used on the inside, dirt will be forced into the pores of the air cleaner element thus restricting air flow through the air cleaner element.

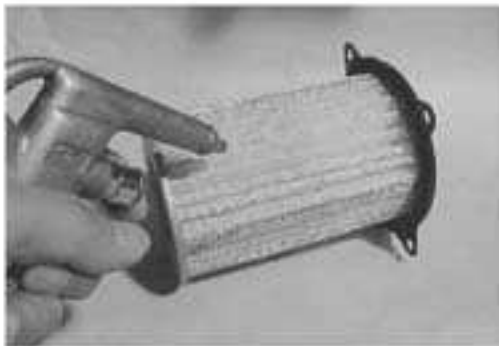

- Reinstall the cleaned or new air cleaner element in the reverse order of removal.

#### CAUTION

If driving under dusty conditions, clean the air cleaner element more frequently. The surest way to accelerate engine wear is to operate the engine without the element or to use a torn element. Make sure that the air cleaner is in good condition at all times. The life of the engine depends largely on this component!

- Remove the drain plugs from the air cleaner box to allow any water to drain out.

## SPARK PLUG

### SPARK PLUG AND SPARK PLUG CAP REMOVAL

- Remove the seat.
- Remove the fuel tank. (☞ 4-48)



- Remove all spark plug caps.
- Remove the spark plugs with a spark plug wrench.



### HEAT RANGE

- Check to see the heat range of the plug.  
If the electrode of the plug is wet appearing or dark color, replace the plug with hotter type one. If it is white or glazed appearing, replace the plug with colder type one.

	NGK	DENSO
Standard	CR8EK	U24ETR
Colder type	CR9EK	U27ETR

#### NOTE:

"R" type spark plug has a resistor located at the center electrode to prevent radio noise.

### CARBON DEPOSITS

- Check to see if there are carbon deposits on the spark plug.
- If carbon is deposited, remove it using a spark plug cleaner machine or carefully use a tool with a pointed end.

### SPARK PLUG GAP

- Measure the spark plug gap using a thickness gauge.
- If out of specification, regap the spark plug.

#### DATA Spark plug gap:

Standard: 0.7 – 0.8 mm (0.028 – 0.031 in)

 09900-20803: Thickness gauge

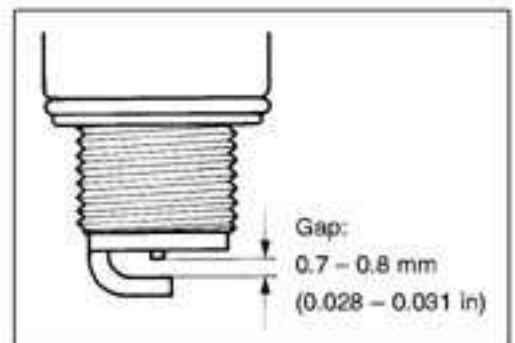
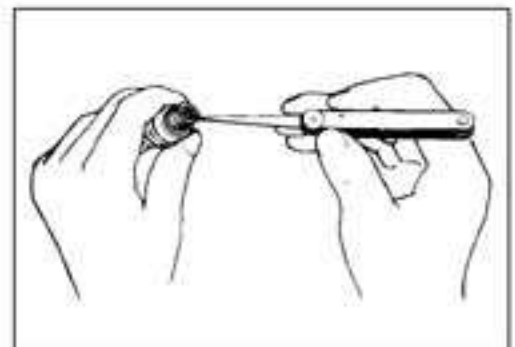

### ELECTRODE'S CONDITION

- Check the condition of the electrode.
- If it is extremely worn or burnt, replace the spark plug. Replace the spark plug if it has a broken insulator, damaged thread, etc.

#### CAUTION

Check the thread size and reach when replacing the spark plug. If the reach is too short, carbon will be deposited on the screw portion of the spark plug hole and engine damage may result.

### SPARK PLUG AND SPARK PLUG CAP INSTALLATION

- Install the spark plugs to the cylinder head by finger tight, and then tighten them to the specified torque.

 Spark plug: 11 N·m (1.1 kgf·m, 8.0 lb-ft)

#### CAUTION

To avoid damaging the cylinder head threads, first finger tighten the spark plug and then tighten it to the proper torque using the spark plug wrench.



### VALVE CLEARANCE

- Remove the fuel tank. (4-48)
- Remove the spark plug caps.
- Remove the ignition coil brackets. Remove the ignition coils.



- Disconnect the cam position sensor coupler.



- Disconnect the PAIR hoses.
- Remove the PAIR valve.



- Remove the engine oil cooler bolts.

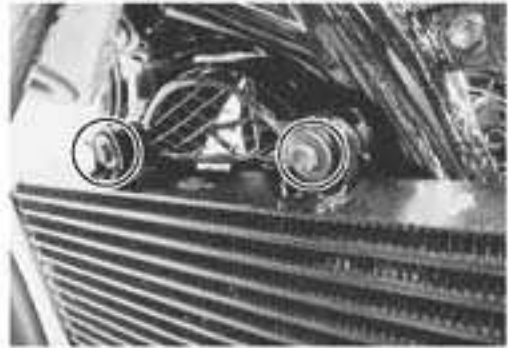

- Remove the engine oil cooler hose clamp.
- Move the engine oil cooler forward.



- Disconnect the cooling fan lead wire coupler.



- Remove the oil hose clamp bolts.



- Remove the cylinder head cover bolts.
- Remove the cylinder head cover.

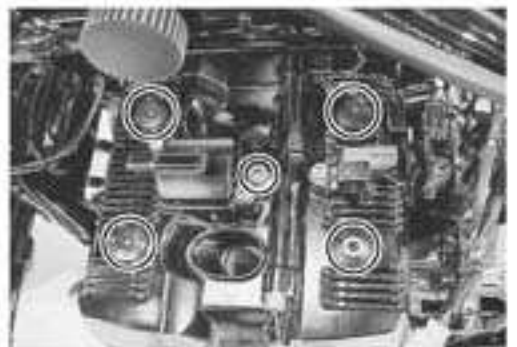

The valve clearance specification is different for intake and exhaust valves.

Valve clearance must be checked and adjusted, 1) at the time of periodic inspection, 2) when the valve mechanism is serviced, and 3) when the camshafts are disturbed by removing them for servicing.

**DATA** Valve clearance (when cold):

Standard: IN. : 0.10 – 0.20 mm (0.004 – 0.008 in)

EX.: 0.20 – 0.30 mm (0.008 – 0.012 in)

**NOTE:**

- \* The cam must be at positions, (A) or (B), in order to check the valve clearance, or to adjust tappet clearance. Clearance readings should not be taken with the cam in any other position than these two positions.
- \* The clearance specification is for COLD state.
- \* To turn the crankshaft for clearance checking, be sure to use a wrench, and rotate in the normal running direction. All spark plugs should be removed.

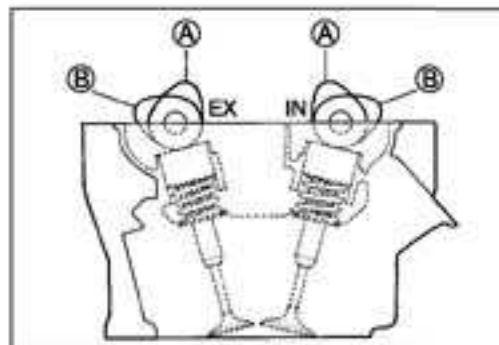

- Remove the signal generator cover.

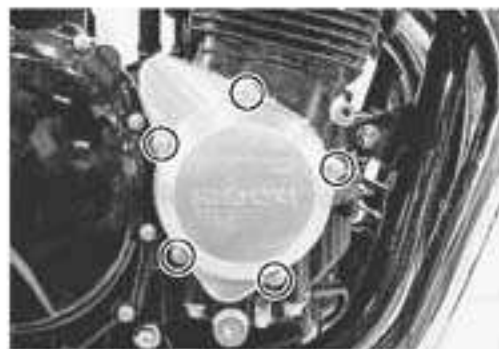

- Turn the crankshaft clockwise until the signal generator rotor line aligns on the signal generator sensor tip.



- Check the exhaust and intake camshaft line positions.



- When the lines face each other, measure • marked valve clearances.

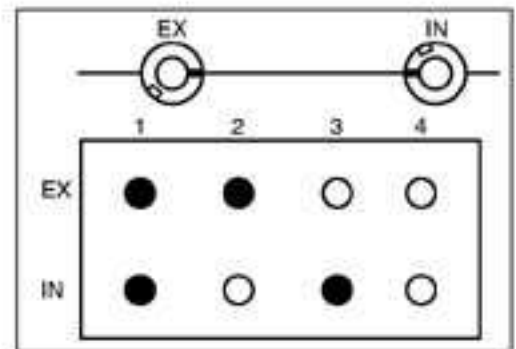

- Turn the crankshaft 360° and measure • marked valve clearances.

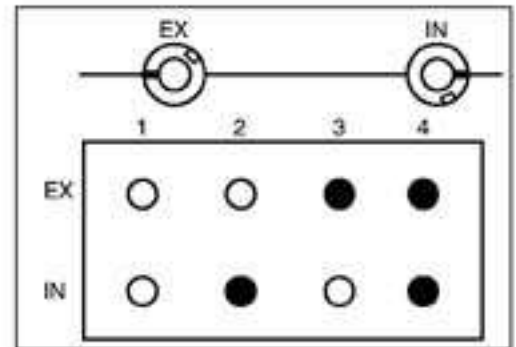

- Measure the valve clearances with a thickness gauge.

 09900-20803: Thickness gauge



### VALVE CLEARANCE ADJUSTMENT

The clearance is adjusted by replacing the existing tappet shim by a thicker or thinner shim.

- Remove the intake or exhaust camshafts. (☞ 3-12)
- Remove the tappet and shim by fingers or magnetic hand.
- Check the figures printed on the shim. These figures indicate the thickness of the shim, as illustrated.
- Select a replacement shim that will provide a clearance within the specified range. For the purpose of this adjustment, a total of 25 sizes of tappet shim are available ranging from 1.20 to 2.20 mm in steps of 0.05 mm. Fit the selected shim to the valve stem end, with numbers toward tappet. Be sure to check shim size with micrometer to ensure its size. Refer to the tappet shim selection table (☞ 2-11, 2-12) for details.

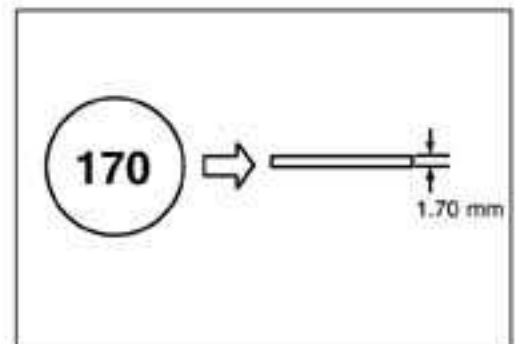

**NOTE:**

- Be sure to apply engine oil to tappet shim top and bottom faces.
- When seating the tappet shim, be sure to face figure printed surface to the tappet.

**CAUTION**

Reinstall the camshafts as the specified manner.  
(☞ 3-74)

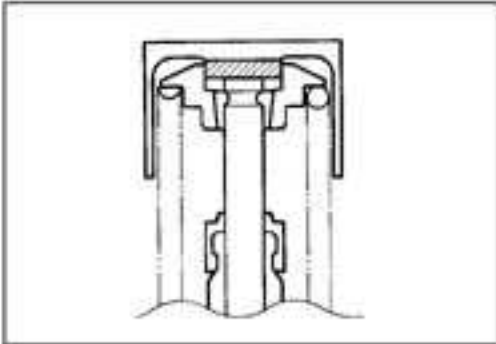

- After replacing the tappet shim and camshafts, rotate the engine so that the tappet is depressed fully. This will squeeze out oil trapped between the shim and the tappet that could cause an incorrect measurement, then check the clearance again to confirm that it is within the specified range.

- After finishing the valve clearance adjustment, reinstall the following parts.
  - Camshafts ..... ☞ 3-74
  - Signal generator cover ..... ☞ 3-77
  - Cylinder head cover ..... ☞ 3-78



(INTAKE SIDE)

TAPPET SHIM SELECTION TABLE (INTAKE)  
TAPPET SHIM NO. (12892-05C00-XXX)

TAPPET SHIM SET (12800-05820)

MEASURED VALVE CLEARANCE (mm)	SUFFIX NO.	PRESENT SHIM SIZE (mm)	SPECIFIED CLEARANCE/NO ADJUSTMENT REQUIRED																				
			120	125	130	135	140	145	150	155	160	165	170	175	180	185	190	195	200	205	210	215	220
0.00-0.04		1.20	1.20	1.25	1.30	1.35	1.40	1.45	1.50	1.55	1.60	1.65	1.70	1.75	1.80	1.85	1.90	1.95	2.00	2.05	2.10	2.15	2.20
0.05-0.09		1.20	1.20	1.25	1.30	1.35	1.40	1.45	1.50	1.55	1.60	1.65	1.70	1.75	1.80	1.85	1.90	1.95	2.00	2.05	2.10	2.15	2.20
0.10-0.20		1.30	1.35	1.40	1.45	1.50	1.55	1.60	1.65	1.70	1.75	1.80	1.85	1.90	1.95	2.00	2.05	2.10	2.15	2.20	2.20	2.20	2.20
0.21-0.25		1.35	1.40	1.45	1.50	1.55	1.60	1.65	1.70	1.75	1.80	1.85	1.90	1.95	2.00	2.05	2.10	2.15	2.20	2.20	2.20	2.20	2.20
0.26-0.30		1.35	1.40	1.45	1.50	1.55	1.60	1.65	1.70	1.75	1.80	1.85	1.90	1.95	2.00	2.05	2.10	2.15	2.20	2.20	2.20	2.20	2.20
0.31-0.35		1.40	1.45	1.50	1.55	1.60	1.65	1.70	1.75	1.80	1.85	1.90	1.95	2.00	2.05	2.10	2.15	2.20	2.20	2.20	2.20	2.20	2.20
0.36-0.40		1.45	1.50	1.55	1.60	1.65	1.70	1.75	1.80	1.85	1.90	1.95	2.00	2.05	2.10	2.15	2.20	2.20	2.20	2.20	2.20	2.20	2.20
0.41-0.45		1.50	1.55	1.60	1.65	1.70	1.75	1.80	1.85	1.90	1.95	2.00	2.05	2.10	2.15	2.20	2.20	2.20	2.20	2.20	2.20	2.20	2.20
0.46-0.50		1.55	1.60	1.65	1.70	1.75	1.80	1.85	1.90	1.95	2.00	2.05	2.10	2.15	2.20	2.20	2.20	2.20	2.20	2.20	2.20	2.20	2.20
0.51-0.55		1.60	1.65	1.70	1.75	1.80	1.85	1.90	1.95	2.00	2.05	2.10	2.15	2.20	2.20	2.20	2.20	2.20	2.20	2.20	2.20	2.20	2.20
0.56-0.60		1.65	1.70	1.75	1.80	1.85	1.90	1.95	2.00	2.05	2.10	2.15	2.20	2.20	2.20	2.20	2.20	2.20	2.20	2.20	2.20	2.20	2.20
0.61-0.65		1.70	1.75	1.80	1.85	1.90	1.95	2.00	2.05	2.10	2.15	2.20	2.20	2.20	2.20	2.20	2.20	2.20	2.20	2.20	2.20	2.20	2.20
0.66-0.70		1.75	1.80	1.85	1.90	1.95	2.00	2.05	2.10	2.15	2.20	2.20	2.20	2.20	2.20	2.20	2.20	2.20	2.20	2.20	2.20	2.20	2.20
0.71-0.75		1.80	1.85	1.90	1.95	2.00	2.05	2.10	2.15	2.20	2.20	2.20	2.20	2.20	2.20	2.20	2.20	2.20	2.20	2.20	2.20	2.20	2.20
0.76-0.80		1.85	1.90	1.95	2.00	2.05	2.10	2.15	2.20	2.20	2.20	2.20	2.20	2.20	2.20	2.20	2.20	2.20	2.20	2.20	2.20	2.20	2.20
0.81-0.85		1.90	1.95	2.00	2.05	2.10	2.15	2.20	2.20	2.20	2.20	2.20	2.20	2.20	2.20	2.20	2.20	2.20	2.20	2.20	2.20	2.20	2.20
0.86-0.90		1.95	2.00	2.05	2.10	2.15	2.20	2.20	2.20	2.20	2.20	2.20	2.20	2.20	2.20	2.20	2.20	2.20	2.20	2.20	2.20	2.20	2.20
0.91-0.95		2.00	2.05	2.10	2.15	2.20	2.20	2.20	2.20	2.20	2.20	2.20	2.20	2.20	2.20	2.20	2.20	2.20	2.20	2.20	2.20	2.20	2.20
0.96-1.00		2.05	2.10	2.15	2.20	2.20	2.20	2.20	2.20	2.20	2.20	2.20	2.20	2.20	2.20	2.20	2.20	2.20	2.20	2.20	2.20	2.20	2.20
1.01-1.05		2.10	2.15	2.20	2.20	2.20	2.20	2.20	2.20	2.20	2.20	2.20	2.20	2.20	2.20	2.20	2.20	2.20	2.20	2.20	2.20	2.20	2.20
1.06-1.10		2.15	2.20	2.20	2.20	2.20	2.20	2.20	2.20	2.20	2.20	2.20	2.20	2.20	2.20	2.20	2.20	2.20	2.20	2.20	2.20	2.20	2.20
1.11-1.15		2.20	2.20	2.20	2.20	2.20	2.20	2.20	2.20	2.20	2.20	2.20	2.20	2.20	2.20	2.20	2.20	2.20	2.20	2.20	2.20	2.20	2.20

HOW TO USE THIS CHART:

- I. Measure valve clearance. "ENGINE IS COLD"
- II. Measure present shim size.
- III. Match clearance in vertical column with present shim size in horizontal column.

EXAMPLE

Valve clearance is 0.23 mm  
Present shim size 1.70 mm  
Shim size to be used 1.80 mm

(EXHAUST SIDE)

TAPPET SHIM SELECTION TABLE [EXHAUST]  
TAPPET SHIM NO. (12892-05C00-XXX)

TAPPET SHIM SET (12800-05820)

MEASURED VALVE CLEARANCE (mm)	SUFFIX NO.	SPECIFIED CLEARANCE/ADJUSTMENT REQUIRED																				
		120	125	130	135	140	145	150	155	160	165	170	175	180	185	190	195	200	205	210	215	220
0.05-0.09	1.30	1.20	1.25	1.30	1.35	1.40	1.45	1.50	1.55	1.60	1.65	1.70	1.75	1.80	1.85	1.90	1.95	2.00	2.05	2.10	2.15	2.20
0.10-0.14	1.20	1.20	1.25	1.30	1.35	1.40	1.45	1.50	1.55	1.60	1.65	1.70	1.75	1.80	1.85	1.90	1.95	2.00	2.05	2.10	2.15	2.20
0.15-0.19	1.20	1.20	1.25	1.30	1.35	1.40	1.45	1.50	1.55	1.60	1.65	1.70	1.75	1.80	1.85	1.90	1.95	2.00	2.05	2.10	2.15	2.20
0.20-0.30	1.30	1.35	1.40	1.45	1.50	1.55	1.60	1.65	1.70	1.75	1.80	1.85	1.90	1.95	2.00	2.05	2.10	2.15	2.20	2.20	2.20	2.20
0.30-0.40	1.35	1.40	1.45	1.50	1.55	1.60	1.65	1.70	1.75	1.80	1.85	1.90	1.95	2.00	2.05	2.10	2.15	2.20	2.20	2.20	2.20	2.20
0.41-0.45	1.40	1.45	1.50	1.55	1.60	1.65	1.70	1.75	1.80	1.85	1.90	1.95	2.00	2.05	2.10	2.15	2.20	2.20	2.20	2.20	2.20	2.20
0.46-0.50	1.45	1.50	1.55	1.60	1.65	1.70	1.75	1.80	1.85	1.90	1.95	2.00	2.05	2.10	2.15	2.20	2.20	2.20	2.20	2.20	2.20	2.20
0.51-0.55	1.50	1.55	1.60	1.65	1.70	1.75	1.80	1.85	1.90	1.95	2.00	2.05	2.10	2.15	2.20	2.20	2.20	2.20	2.20	2.20	2.20	2.20
0.56-0.60	1.55	1.60	1.65	1.70	1.75	1.80	1.85	1.90	1.95	2.00	2.05	2.10	2.15	2.20	2.20	2.20	2.20	2.20	2.20	2.20	2.20	2.20
0.61-0.65	1.60	1.65	1.70	1.75	1.80	1.85	1.90	1.95	2.00	2.05	2.10	2.15	2.20	2.20	2.20	2.20	2.20	2.20	2.20	2.20	2.20	2.20
0.66-0.70	1.65	1.70	1.75	1.80	1.85	1.90	1.95	2.00	2.05	2.10	2.15	2.20	2.20	2.20	2.20	2.20	2.20	2.20	2.20	2.20	2.20	2.20
0.71-0.75	1.70	1.75	1.80	1.85	1.90	1.95	2.00	2.05	2.10	2.15	2.20	2.20	2.20	2.20	2.20	2.20	2.20	2.20	2.20	2.20	2.20	2.20
0.76-0.80	1.75	1.80	1.85	1.90	1.95	2.00	2.05	2.10	2.15	2.20	2.20	2.20	2.20	2.20	2.20	2.20	2.20	2.20	2.20	2.20	2.20	2.20
0.81-0.85	1.80	1.85	1.90	1.95	2.00	2.05	2.10	2.15	2.20	2.20	2.20	2.20	2.20	2.20	2.20	2.20	2.20	2.20	2.20	2.20	2.20	2.20
0.86-0.90	1.85	1.90	1.95	2.00	2.05	2.10	2.15	2.20	2.20	2.20	2.20	2.20	2.20	2.20	2.20	2.20	2.20	2.20	2.20	2.20	2.20	2.20
0.91-0.95	1.90	1.95	2.00	2.05	2.10	2.15	2.20	2.20	2.20	2.20	2.20	2.20	2.20	2.20	2.20	2.20	2.20	2.20	2.20	2.20	2.20	2.20
0.96-1.00	1.95	2.00	2.05	2.10	2.15	2.20	2.20	2.20	2.20	2.20	2.20	2.20	2.20	2.20	2.20	2.20	2.20	2.20	2.20	2.20	2.20	2.20
1.01-1.05	2.00	2.05	2.10	2.15	2.20	2.20	2.20	2.20	2.20	2.20	2.20	2.20	2.20	2.20	2.20	2.20	2.20	2.20	2.20	2.20	2.20	2.20
1.06-1.10	2.05	2.10	2.15	2.20	2.20	2.20	2.20	2.20	2.20	2.20	2.20	2.20	2.20	2.20	2.20	2.20	2.20	2.20	2.20	2.20	2.20	2.20
1.11-1.15	2.10	2.15	2.20	2.20	2.20	2.20	2.20	2.20	2.20	2.20	2.20	2.20	2.20	2.20	2.20	2.20	2.20	2.20	2.20	2.20	2.20	2.20
1.16-1.20	2.15	2.20	2.20	2.20	2.20	2.20	2.20	2.20	2.20	2.20	2.20	2.20	2.20	2.20	2.20	2.20	2.20	2.20	2.20	2.20	2.20	2.20
1.21-1.25	2.20	2.20	2.20	2.20	2.20	2.20	2.20	2.20	2.20	2.20	2.20	2.20	2.20	2.20	2.20	2.20	2.20	2.20	2.20	2.20	2.20	2.20

HOW TO USE THIS CHART:

- i. Measure valve clearance. "ENGINE IS COLD"
- ii. Measure present shim size.
- iii. Match clearance in vertical column with present shim size in horizontal column.

EXAMPLE

Valve clearance is 0.33 mm  
Present shim size 1.70 mm  
Shim size to be used 1.80 mm

## ENGINE OIL AND OIL FILTER

Oil should be changed while the engine is warm. Oil filter replacement at the specified intervals, should be done together with the engine oil change.

### ENGINE OIL REPLACEMENT

- Keep the motorcycle upright.
- Place an oil pan below the engine, and drain oil by removing the oil drain plug ① and filler cap ②.
- Tighten the drain plug ① to the specified torque, and pour fresh oil through the oil filler. The engine will hold about 4.2 L (4.4/3.7 US/Imp qt) of oil. Use an API classification of SF or SG oil with SAE 10W/40 viscosity.

 Oil drain plug: 23 N·m (2.3 kgf·m, 16.5 lb-ft)

- Start up the engine and allow it to run for several minutes at idling speed.
- Turn off the engine and wait about three minutes, then check the oil level through the inspection window. If the level is below mark "L", add oil to "F" level. If the level is above mark "F", drain oil to "F" level.

### OIL FILTER REPLACEMENT

- Drain the engine oil as described in the engine oil replacement procedure.
- Remove the oil filter ① using the special tool.

 09915-40610: Oil filter wrench

- Apply engine oil lightly to the gasket of the new oil filter before installation.



- Install the new oil filter. Turn it by hand until you feel that the oil filter gasket has contacted the oil filter mounting surface. Then, tighten the oil filter two full turns using the special tool.

**NOTE:**

To properly tighten the oil filter, use the special tool. Never tighten the oil filter by hand.

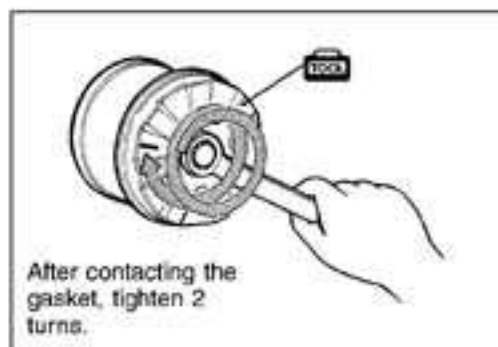

- Add new engine oil and check the oil level as described in the engine oil replacement procedure.

**DATA NECESSARY AMOUNT OF ENGINE OIL:**

Oil change: 4.2L (4.4/3.7 US/Imp qt)

Oil and filter change: 4.8L (5.1/4.2 US/Imp qt)

Engine overhaul: 5.7L (6.0/5.0 US/Imp qt)

**CAUTION**

**ONLY USE A GENUINE SUZUKI MOTORCYCLE OIL FILTER.** Other manufacturer's oil filters may differ in thread specifications (thread diameter and pitch), filtering performance and durability which may lead to engine damage or oil leaks. Also, do not use a genuine Suzuki automobile oil filter on this motorcycle.

**FUEL HOSE**

Inspect the fuel hose ① for damage and fuel leakage. If any defects are found, the hoses must be replaced.



**ENGINE IDLE SPEED**

**NOTE:**

Make this adjustment when the engine is hot.

- Start the engine, turn the throttle stop screw and set the engine idle speed as follows.

**DATA Engine idle speed: 1 100 ± 100 rpm**



## THROTTLE VALVE SYNCHRONIZATION

Inspect throttle valve synchronization periodically. (☞ 4-66)

### THROTTLE CABLE PLAY

Adjust the throttle cable play **A** as follows.

#### MINOR ADJUSTMENT

1st step:

- Loosen the locknut **1** of the throttle returning cable **2** and fully turn in the adjuster **3**.

2nd step:

- Loosen the locknut **4** of the throttle pulling cable **5**.
- Turn the adjuster **6** in or out until the throttle cable play (at the throttle grip) **A** is between 2.0 – 4.0 mm (0.08 – 0.16 in).
- Tighten the locknut **4** while holding the adjuster **6**.

**DATA** Throttle cable play **A**: 2.0 – 4.0 mm (0.08 – 0.16 in)

3rd step:

- While holding the throttle grip at the fully closed position, slowly turn out the adjuster **3** of the throttle returning cable **2** until resistance is felt.
- Tighten the locknut **1** while holding the adjuster **3**.

#### **▲ WARNING**

After the adjustment is completed, check that handlebar movement does not raise the engine idle speed and that the throttle grip returns smoothly and automatically.

**NOTE:**

Major adjustment can be made at the throttle body side adjuster.

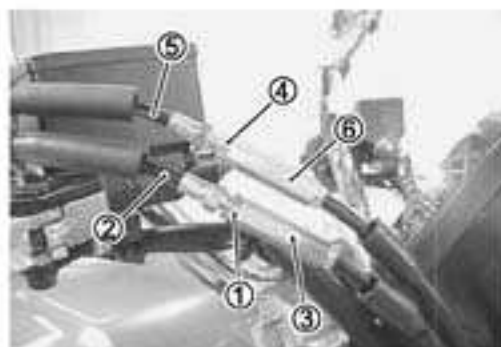

**MAJOR ADJUSTMENT**

- Lift and support the fuel tank with its prop stay. (☞ 4-48)
- Loosen the lock nuts ① of the throttle returning cable ②.
- Turn the returning cable adjuster ③ to obtain proper cable play.
- Loosen the lock nuts ④ of the throttle pulling cable ⑤.
- Turn the pulling cable adjuster ⑥ in or out until the throttle cable play ⑧ should be 2.0 – 4.0 mm (0.08 – 0.16 in) at the throttle grip.
- Tighten the lock nuts ④ securely while holding the adjuster ⑥.

**DATA** Throttle cable play ⑧: 2.0 – 4.0 mm (0.08 – 0.16 in)

- While holding the throttle grip at the fully closed position, slowly turn the returning cable adjuster ③ to obtain a cable slack of 1.0 mm (0.04 in).
- Tighten the lock nuts ① securely.

**⚠ WARNING**

After the adjustment is completed, check that handlebar movement does not raise the engine idle speed and that the throttle grip returns smoothly and automatically.

**CLUTCH****CLUTCH FLUID LEVEL**

- Keep the motorcycle upright and place the handlebars straight.
- Check the clutch fluid level by observing the lower limit line on the clutch fluid reservoir.
- If the level is found to be lower than the lower mark, replenish with BRAKE FLUID that the following specification.

**Specification and Classification: DOT 4**

**⚠ WARNING**

The clutch system of this motorcycle is filled with a glycol-based brake fluid. Do not use or mix different types of fluid such as silicone-based or petroleum-based. Do not use any brake fluid taken from old, used or unsealed containers. Never re-use brake fluid left over from the last servicing or stored for a long periods. Check the clutch hose and hose joints for cracks and fluid leakage.

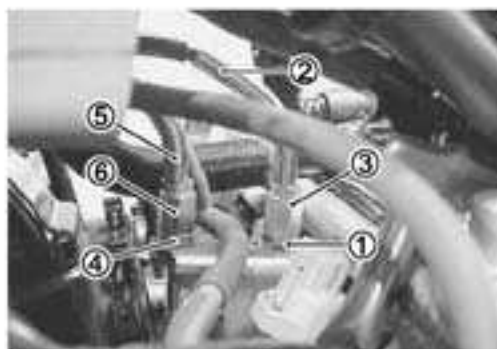



### BLEEDING AIR FROM THE CLUTCH FLUID CIRCUIT

The clutch fluid circuit may be purged of air in the following manner.

- Keep the motorcycle upright and place the handlebars straight.
- Fill up the master cylinder reservoir to the upper end of the inspection window. Replace the reservoir cap to prevent entry of dirt.
- Attach a pipe to the bleeder valve and insert the free end of the pipe into a receptacle.
- Squeeze and release the clutch lever several times in rapid succession, and squeeze the lever fully without releasing it. Loosen the bleeder valve by turning it a quarter of a turn so that the fluid runs into the receptacle; this will remove the tension of the clutch lever causing it to touch the handlebar grip. Then, close the valve, pump and squeeze the lever, and open the valve. Repeat this process until the fluid flowing into the receptacle no longer contains air bubbles.
- Close the bleeder valve, and disconnect the pipe. Fill the reservoir with brake fluid to the upper end of the inspection window.

 **Air bleeder valve: 8 N·m (0.8 kgf·m, 6.0 lb-ft)**

### DRIVE CHAIN

Visually check the drive chain for the possible defects listed below. (Support the motorcycle by a jack and a wooden block, turn the rear wheel slowly by hand with the transmission shifted to Neutral.)

- Loose pins
- Excessive wear
- Damaged rollers
- Improper chain adjustment
- Dry or rusted links
- Missing O-ring seals
- Kinked or binding links

If any defects are found, the drive chain must be replaced.

#### NOTE:

*When replacing the drive chain, replace the drive chain and sprockets as a set.*

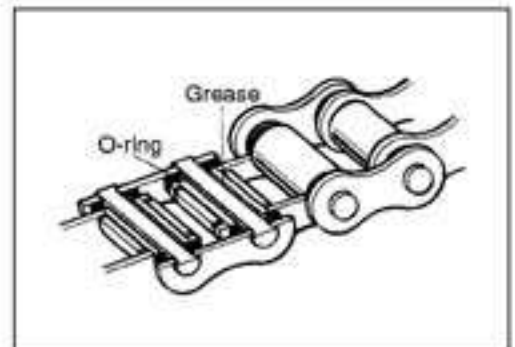



**CHECKING**

- Loosen the axle nut ①.
- Loosen the chain adjuster lock nuts ②.
- Loosen the torque link nut (Rear) ③.
- Tense the drive chain fully by turning both chain adjusters ④.

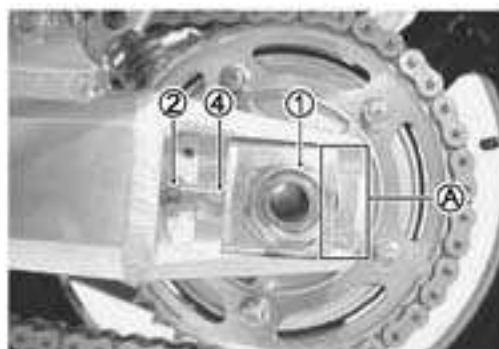

- Count out 21 pins (20 pitches) on the chain and measure the distance between the two points. If the distance exceeds the service limit, the chain must be replaced.

**DATA** Drive chain 20-pitch length:  
Service limit: 319.4 mm (12.57 in)

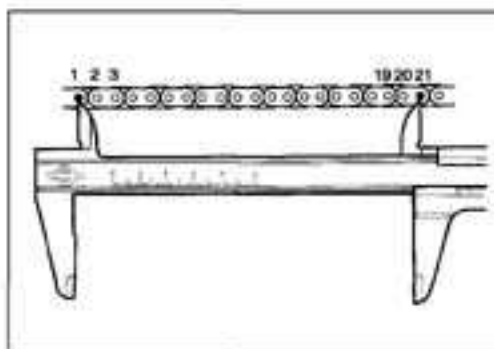
**ADJUSTING**

- Loosen or tighten both chain adjuster nuts ① until there is 20 – 30 mm (0.8 – 1.2 in) of slack at the middle of the chain between the engine and rear sprockets as shown. The reference marks ① on both sides of the swingarm and the edge of each chain adjuster must be aligned to ensure that the front and rear wheels are correctly aligned.

**DATA** Drive chain slack:  
Standard: 20 – 30 mm (0.8 – 1.2 in)

- Place the motorcycle on its side-stand for accurate adjustment.
- After adjusting the drive chain, tighten the axle nut ② and the torque link nut (Rear) ③ to the specified torque.
- Tighten both chain adjuster nuts ④ securely.

**🔧** Rear axle nut: 110 N·m (11.0 kgf·m, 79.6 lb-ft)  
Torque link nut (Rear): 34 N·m (3.4 kgf·m, 24.6 lb-ft)

- Recheck the drive chain slack after tightening the axle nut.

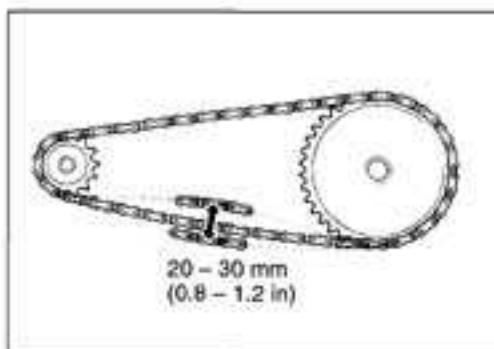

## CLEANING AND LUBRICATING

- Clean the drive chain with kerosine. If the drive chain tends to rust quickly, the intervals must be shortened.

### CAUTION

Do not use trichloroethylene, gasoline or any similar solvent. These fluids have too great a dissolving power for this chain and they can damage the O-rings. Use only kerosine to clean the drive chain.

- After washing and drying the chain, oil it with a heavyweight motor oil.

### CAUTION

- Do not use any oil sold commercially as "drive chain oil". Such oil can damage the O-rings.
- The standard drive chain is a RK GB50GSVZ3 Suzuki recommends to use this standard drive chain as a replacement.



## BRAKE

### BRAKE FLUID LEVEL CHECK

- Keep the motorcycle upright and place the handlebars straight.
- Check the brake fluid level by observing the lower limit lines on the front and rear brake fluid reservoirs.
- When the level is below the lower limit line, replenish with brake fluid that meets the following specification.

 Specification and Classification: DOT 4

### ⚠ WARNING

- The brake system of this motorcycle is filled with a glycol-based brake fluid. Do not use or mix different types of fluid such as silicone-based and petroleum-based fluids. Do not use any brake fluid taken from old, used or unsealed containers. Never re-use brake fluid left over from the last servicing or stored for a long period of time.
- Brake fluid, if it leaks, will interfere with safe running and immediately discolor painted surfaces. Check the brake hoses and hose joints for cracks and fluid leakage before riding.



**BRAKE PADS****FRONT BRAKE**

- The extent of brake pad wear can be checked by observing the grooved limit line **A** on the pad. When the wear exceeds the grooved limit line, replace the pads with new ones. (☞ 6-50)

**CAUTION**

Replace the brake pads as a set, otherwise braking performance will be adversely affected.

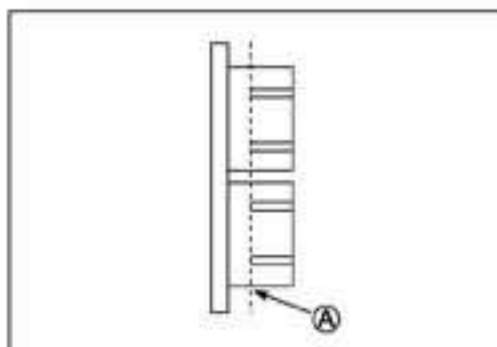
**REAR BRAKE**

- The extent of brake pad wear can be checked by observing the grooved limit line **A** on the pad. When the wear exceeds the grooved limit line, replace the pads with new ones. (☞ 6-58)

**CAUTION**

Replace the brake pads as a set, otherwise braking performance will be adversely affected.

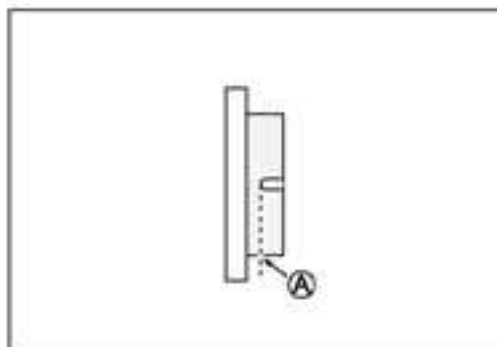
**BRAKE PEDAL HEIGHT**

- Loosen the locknut **1**.
- Turn the push rod **2** until the brake pedal is 35 – 45 mm (1.4 – 1.8 in) **A** below the top of the footrest.
- Tighten the locknut **1** securely.

**U** Rear brake master cylinder rod locknut:  
18 N·m (1.8 kgf·m, 13.0 lb-ft)

**DATA** Brake pedal height **A**:  
Standard: 35 – 45 mm (1.4 – 1.8 in)



### BRAKE LIGHT SWITCH

- Adjust the rear brake light switch so that the brake light will come on just before pressure is felt when the brake pedal is depressed.



### AIR BLEEDING THE BRAKE FLUID CIRCUIT

Air trapped in the brake fluid circuit acts like a cushion to absorb a large proportion of the pressure developed by the master cylinder and thus interferes with the full braking performance of the brake caliper. The presence of air is indicated by "sponginess" of the brake lever and also by lack of braking force. Considering the danger to which such trapped air exposes the machine and rider, it is essential that after remounting the brake and restoring the brake system to the normal condition, the brake fluid circuit be purged of air in the following manner:

#### FRONT BRAKE

- Fill the master cylinder reservoir to the top of the inspection window. Replace the reservoir cap to prevent dirt from entering.
- Attach a hose to the air bleeder valve and insert the free end of the hose into a receptacle.
- Squeeze and release the brake lever several times in rapid succession and squeeze the lever fully without releasing it. Loosen the air bleeder valve by turning it a quarter of a turn so that the brake fluid runs into the receptacle, this will remove the tension of the brake lever causing it to touch the handlebar grip. Then, close the air bleeder valve, pump and squeeze the lever, and open the valve. Repeat this process until fluid flowing into the receptacle no longer contains air bubbles.



#### NOTE:

*While bleeding the brake system, replenish the brake fluid in the reservoir as necessary. Make sure that there is always some fluid visible in the reservoir.*

- Close the air bleeder valve and disconnect the hose. Fill the reservoir with brake fluid to the top of the inspection window.

 Air bleeder valve: 8 N·m (0.8 kgf·m, 6.0 lb-ft)

### CAUTION

Handle brake fluid with care: the fluid reacts chemically with paint, plastics, rubber materials, etc.

## REAR BRAKE

- Bleed air from the rear brake system as the same manner of front brake.

### NOTE:

The only difference between bleeding the front and rear brakes is that the rear master cylinder is actuated by a pedal.



## TIRES

### TIRE TREAD CONDITION

Operating the motorcycle with excessively worn tires will decrease riding stability and consequently invite a dangerous situation. It is highly recommended to replace a tire when the remaining depth of tire tread reaches the following specification.

 09900-20805: Tire depth gauge

**DATA** Tire tread depth:

Service Limit: **FRONT 1.6 mm (0.06 in)**  
**REAR 2.0 mm (0.08 in)**

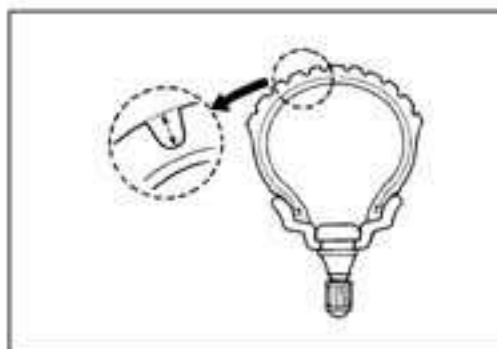

## TIRE PRESSURE

If the tire pressure is too high or too low, steering will be adversely affected and tire wear will increase. Therefore, maintain the correct tire pressure for good roadability and a longer tire life. Cold inflation tire pressure is as follows.

### **DATA** Cold inflation tire pressure

Solo riding:	Front:	250 kPa (2.50 kgf/cm <sup>2</sup> , 36 psi)
	Rear:	250 kPa (2.50 kgf/cm <sup>2</sup> , 36 psi)
Dual riding:	Front:	250 kPa (2.50 kgf/cm <sup>2</sup> , 36 psi)
	Rear:	290 kPa (2.90 kgf/cm <sup>2</sup> , 42 psi)

### **CAUTION**

The standard tire fitted on this motorcycle is a 120/70 ZR17 (58W) for the front and a 190/50 ZR17 (73W) for the rear. The use of tires other than those specified may cause instability. It is highly recommended to use the specified tires.

### **DATA** TIRE TYPE

BRIDGESTONE (BT020F F.....Front, BT020R.....Rear)

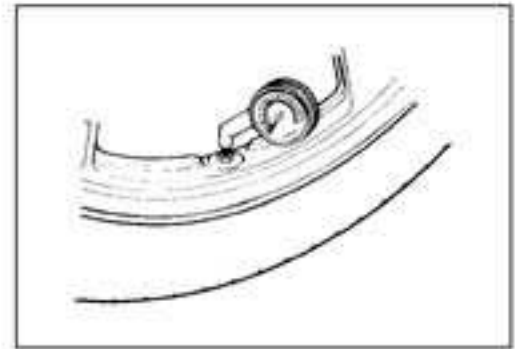

## STEERING

The steering should be adjusted properly for smooth turning of the handlebars and safe operation. Overtight steering prevents smooth turning of the handlebars and too loose steering will cause poor stability. Check that there is no play in the front fork. Support the motorcycle so that the front wheel is off the ground. With the wheel facing straight ahead, grasp the lower fork tubes near the axle and pull forward. If play is found, readjust the steering. (☞ 6-31)





## FRONT FORK

Inspect the front forks for oil leakage, scoring or scratches on the outer surface of the inner tubes. Replace any defective parts, if necessary. (🔧 6-13)



## REAR SUSPENSION

Inspect the rear shock absorbers for oil leakage and check that there is no play in the swingarm. Replace any defective parts if necessary. (🔧 6-41)



## EXHAUST PIPE BOLT AND NUT

• Tighten the exhaust pipe bolts, muffler mounting bolt and nut to the specified torque.

- 🔧 Exhaust pipe bolt ①: 23 N·m (2.3 kgf·m, 16.5 lb-ft)
- Muffler connecting bolt ②: 24 N·m (2.4 kgf·m, 17.5 lb-ft)
- Muffler mounting bolt ③: 23 N·m (2.3 kgf·m, 16.5 lb-ft)
- Exhaust pipe connecting bolt: 20 N·m  
(2.0 kgf·m, 14.4 lb-ft)





## CHASSIS BOLTS AND NUTS

Check that all chassis bolts and nuts are tightened to their specified torque. The locations of the following nuts and bolts on the motorcycle.:  2-26

Item	N·m	kgf·m	lb·ft
① Steering stem head nut	65	6.5	47.0
② Steering stem lock nut	80	8.0	58.0
③ Front fork upper clamp bolt	23	2.3	16.5
④ Front fork lower clamp bolt	23	2.3	16.5
⑤ Front axle	100	10.0	72.5
⑥ Front axle pinch bolt	23	2.3	16.5
⑦ Handlebar set bolt	23	2.3	16.5
⑧ Handlebar clamp bolt	95	9.5	68.5
⑨ Front brake master cylinder mounting bolt	10	1.0	7.0
⑩ Front brake caliper mounting bolt	26	2.6	19.0
⑪ Brake hose union bolt (Front & Rear)	23	2.3	16.5
⑫ Caliper air bleeder valve (Front & Rear)	8	0.8	6.0
⑬ Brake disc bolt	23	2.3	16.5
⑭ Rear brake caliper mounting bolt	26	2.6	20.0
⑮ Rear brake master cylinder mounting bolt	10	1.0	7.3
⑯ Rear brake master cylinder rod lock nut	18	1.8	13.0
⑰ Front footrest bracket mounting bolt	26	2.6	19.0
⑱ Swingarm pivot nut	100	10.0	72.5
⑲ Torque link bolt and nut (Front)	28	2.8	20.0
⑳ Torque link bolt and nut (Rear)	34	3.4	24.6
㉑ Rear shock absorber (Upper)	23	2.3	16.5
㉒ Rear shock absorber (Lower)	34	3.4	24.5
㉓ Rear axle nut	100	10.0	72.5
㉔ Rear sprocket nut	60	6.0	43.5

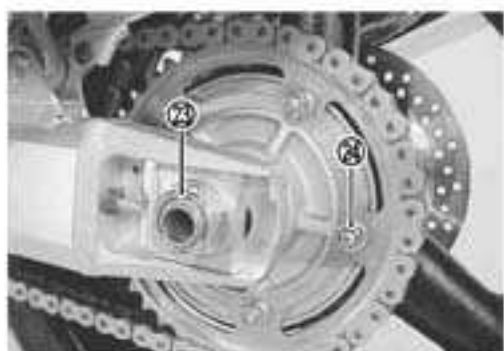
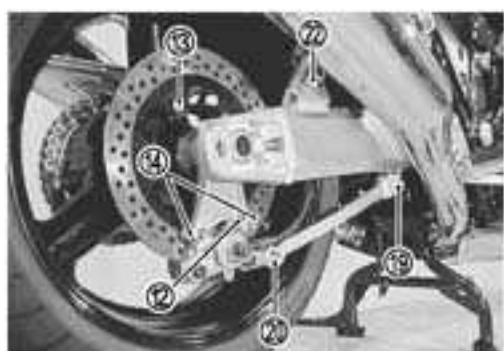
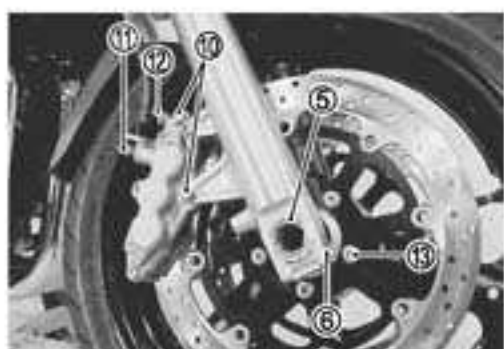
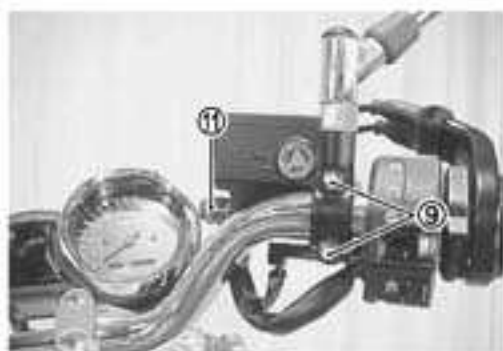
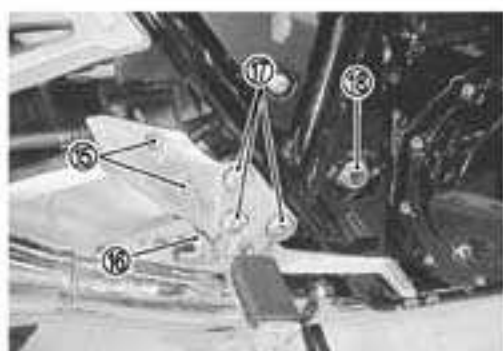
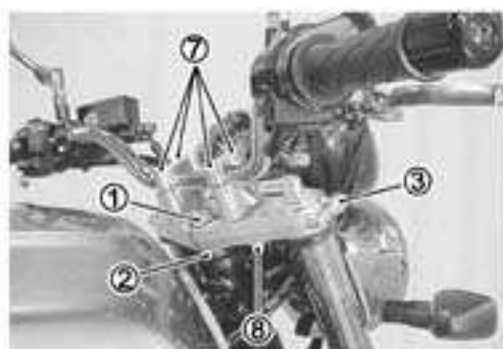

## COMPRESSION PRESSURE CHECK

The compression pressure reading of a cylinder is a good indicator of its internal condition.

The decision to overhaul the cylinder is often based on the results of a compression test. Periodic maintenance records kept at your dealership should include compression readings for each maintenance service.

### COMPRESSION PRESSURE SPECIFICATION

Standard	Limit	Difference
1 180 kPa (11.8 kgf/cm <sup>2</sup> ) (168 psi)	880 kPa (8.8 kgf/cm <sup>2</sup> ) (125 psi)	200kPa (2 kgf/cm <sup>2</sup> ) (28 psi)

**Low compression pressure can indicate any of the following conditions:**

- Excessively worn cylinder walls
- Worn piston or piston rings
- Piston rings stuck in grooves
- Poor valve seating
- Ruptured or otherwise defective cylinder head gasket

**Overhaul the engine in the following cases:**

- Compression pressure in one of the cylinders is less than 900 kPa (9 kg/cm<sup>2</sup>, 128 psi).
- The difference in compression pressure between any two cylinders is more than 200 kPa (2 kgf/cm<sup>2</sup>, 28 psi).
- All compression pressure readings are below 1 100 kPa (11 kgf/cm<sup>2</sup>, 156 psi) even when they measure more than 900 kPa (9 kgf/cm<sup>2</sup>, 128 psi).

## COMPRESSION TEST PROCEDURE

### NOTE:

- Before testing the engine for compression pressure, make sure that the cylinder head nuts are tightened to the specified torque values and the valves are properly adjusted.
- Have the engine warmed up before testing.
- Make sure that the battery is fully-charged.

Remove the related parts and test the compression pressure in the following manner.

- Lift and support the fuel tank. (☞ 4-48)
- Remove all the spark plugs. (☞ 2-5)
- Install the compression gauge and adaptor in the spark plug hole. Make sure that the connection is tight.
- Keep the throttle grip in the fully opened position.
- Press the starter button and crank the engine for a few seconds. Record the maximum gauge reading as the cylinder compression.
- Repeat this procedure with the other cylinders.

 09915-64510: Compression gauge set  
09913-10750: Adaptor



## OIL PRESSURE CHECK

Check the engine oil pressure periodically. This will give a good indication of the condition of the moving parts.

### OIL PRESSURE SPECIFICATION

**300 – 600 kPa (3.0 – 6.0 kgf/cm<sup>2</sup>, 43 – 85 psi) at 3 000 r/min., Oil temp. at 60°C (140°F)**

If the oil pressure is lower or higher than the specification, the following causes may be considered.

#### LOW OIL PRESSURE

- \* Clogged oil filter
- \* Oil leakage from the oil passage
- \* Damaged O-ring
- \* Defective oil pump
- \* Combination of the above items

#### HIGH OIL PRESSURE

- \* Engine oil viscosity is too high
- \* Clogged oil passage
- \* Combination of the above items

### OIL PRESSURE TEST PROCEDURE

Start the engine and check if the oil pressure indicator light is turned on. If the light stays on, check the oil pressure indicator light circuit. If the circuit is OK, check the oil pressure in the following manner.

- Remove the main oil gallery plug.
- Install the oil pressure gauge and adaptor into the main oil gallery.
- Warm up the engine as follows:  
Summer: 10 min. at 2 000 r/min.  
Winter: 20 min. at 2 000 r/min.
- After warming up, increase the engine speed to 3 000 r/min. (observe the tachometer), and read the oil pressure gauge.

-  09915-74520: Oil pressure gauge hose
- 09915-74540: Oil pressure gauge attachment
- 09915-77330: Meter (for high pressure)

-  Oil gallery plug (M16): 35 N·m (3.5 kgf·m, 25.5 lb-ft)



# ENGINE

## CONTENTS

<b>ENGINE COMPONENTS REMOVABLE WITH THE ENGINE IN PLACE .....</b>	<b>3- 2</b>
<b>ENGINE REMOVAL AND INSTALLATION .....</b>	<b>3- 3</b>
<b>ENGINE REMOVAL .....</b>	<b>3- 3</b>
<b>ENGINE INSTALLATION .....</b>	<b>3- 8</b>
<b>ENGINE DISASSEMBLY .....</b>	<b>3-11</b>
<b>ENGINE COMPONENTS INSPECTION AND SERVICE .....</b>	<b>3-22</b>
<b>PAIR VALVE .....</b>	<b>3-22</b>
<b>CYLINDER HEAD COVER .....</b>	<b>3-23</b>
<b>CAMSHAFT .....</b>	<b>3-23</b>
<b>CAM CHAIN TENSION ADJUSTER.....</b>	<b>3-25</b>
<b>CAM CHAIN TENSIONER/CAM CHAIN GUIDE .....</b>	<b>3-25</b>
<b>CYLINDER HEAD AND VALVE .....</b>	<b>3-26</b>
<b>CYLINDER .....</b>	<b>3-34</b>
<b>PISTON AND PISTON RING .....</b>	<b>3-35</b>
<b>CLUTCH .....</b>	<b>3-37</b>
<b>GEARSHIFT SYSTEM.....</b>	<b>3-39</b>
<b>GENERATOR .....</b>	<b>3-40</b>
<b>OIL PUMP .....</b>	<b>3-40</b>
<b>OIL PRESSURE REGULATOR/OIL STRAINER .....</b>	<b>3-41</b>
<b>CRANK BALANCER .....</b>	<b>3-41</b>
<b>TRANSMISSION .....</b>	<b>3-42</b>
<b>CRANKSHAFT AND CONROD.....</b>	<b>3-45</b>
<b>CRANKCASE/OIL PAN .....</b>	<b>3-53</b>
<b>ENGINE REASSEMBLY .....</b>	<b>3-56</b>

## ENGINE COMPONENTS REMOVABLE WITH ENGINE IN PLACE

The parts listed below can be removed and reinstalled without removing the engine from the frame. Refer to page listed in each section for removal and reinstallation instructions.

### ENGINE CENTER

ITEM	REMOVAL	INSPECTION	REINSTALLATION
Oil cooler	☞ 3-4	—	☞ 3-10
Exhaust pipe and muffler	☞ 3-4	—	☞ 3-9
PAIR valve	☞ 3-11	☞ 3-22	☞ 3-78
Cylinder head cover	☞ 3-11	☞ 3-23	☞ 3-78
Cam chain tension adjuster	☞ 3-12	☞ 3-25	☞ 3-76
Camshaft	☞ 3-12	☞ 3-23	☞ 3-74
Cylinder head	☞ 3-12	☞ 3-26	☞ 3-72
Cylinder	☞ 3-13	☞ 3-34	☞ 3-72
Piston	☞ 3-14	☞ 3-35	☞ 3-71
Breather cover	☞ 3-14	—	☞ 3-70
Oil temperature sensor	☞ 3-14	☞ 5-11	☞ 3-70
Oil filter	☞ 3-15	—	☞ 3-69
Oil pan	☞ 3-19	☞ 3-53	☞ 3-62
Oil strainer	☞ 3-19	☞ 3-41	☞ 3-62
Crank balancer	☞ 3-19	☞ 3-40	☞ 3-60

### ENGINE RIGHT SIDE

Signal generator cover	☞ 3-11	—	☞ 3-77
Signal generator rotor	☞ 3-15	—	☞ 3-69
Signal generator(CKP sensor)	☞ 3-15	☞ 7-21	☞ 3-69
Cooling fan switch	☞ 3-15	☞ 5-10	☞ 3-70
Clutch cover	☞ 3-16	—	☞ 3-65
Clutch (plates)	☞ 3-16	☞ 3-37	☞ 3-65
Gearshift shaft	☞ 3-17	☞ 3-39	☞ 3-65
Oil pump driven gear	☞ 3-17	—	☞ 3-65

### ENGINE LEFT SIDE

Gearshift arm	☞ 3-5	—	☞ 3-9
Engine sprocket	☞ 3-7	—	☞ 3-9
Starter motor	☞ 3-14	☞ 7-13	☞ 3-70
Generator(Cover)	☞ 3-18	☞ 3-40	☞ 3-64
Starter idle gear	☞ 3-18	—	☞ 3-63
Generator rotor/Starter clutch	☞ 3-18	☞ 4-40	☞ 3-63
Gear position sensor	☞ 3-18	☞ 7-15	☞ 3-63
Clutch release cylinder	☞ 6-65	☞ 6-65	☞ 6-65



## ENGINE REMOVAL AND INSTALLATION

### ENGINE REMOVAL

Before taking the engine out of the frame, wash the engine using a steam cleaner. Engine removal is sequentially explained in the following steps. Reinstall the engine by reversing the removal procedure.

- Remove the seat. (☞6-3)
- Remove the frame side cover. (☞6-3)
- Remove the fuel tank. (☞4-48)



- Remove the tray.



- Remove the battery .



- Drain engine oil.





### OIL COOLER

- Remove the cooling fan coupler (2P).



- Remove the oil hose union and oil hose guide.



- With the oil cooler bolts removed, detach the oil cooler and cooling fan.



### EXHAUST PIPE AND MUFFLER

- Loosen the muffler connecting bolts, ① and ②.
- With the muffler mounting nuts (③ and ④) removed, remove the mufflers (R, L).
- With the exhaust pipe bolts and exhaust pipe mounting bolt ⑤ removed, remove the exhaust pipe assembly.

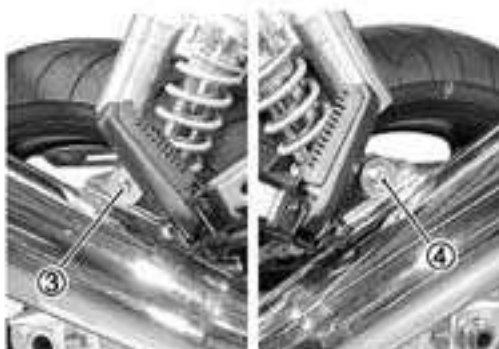
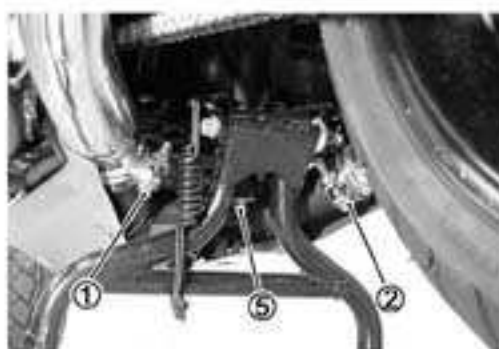

**IGNITION COIL**

- With the ignition coil couplers and plug caps disconnected, remove the ignition coil brackets (R, L).



- Disconnect the CMP sensor.



- Disconnect the breather hose.
- Remove the throttle body assembly. (☞ 4-55)

**ELECTRIC PARTS**

- Disconnect the oil temperature sensor coupler (2P)①.
- Disconnect the signal generator (CKP sensor)/oil pressure switch coupler (3P) ②.
- Disconnect the cooling fan switch coupler (2P)③.



- Disconnect the ground lead wire coupler.



- Disconnect the gear position switch coupler (3P) ① and side-stand switch coupler (2P) ②.

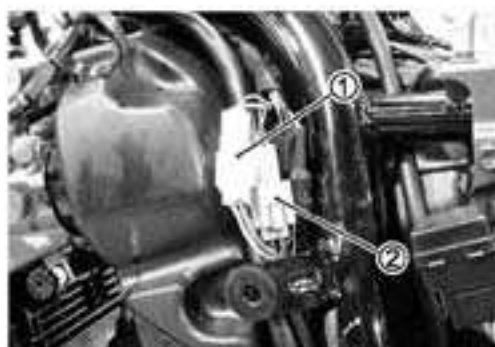

- Remove the starter motor lead wire.



#### GEARSHIFT LEVER

- Disconnect the gearshift lever linkage.



#### ENGINE SPROCKET

- Remove the engine sprocket cover.



- Disconnect the generator coupler (3P) ①.
- Remove the clutch release cylinder housing.

#### CAUTION

Do not operate the clutch lever after removing the clutch release housing.

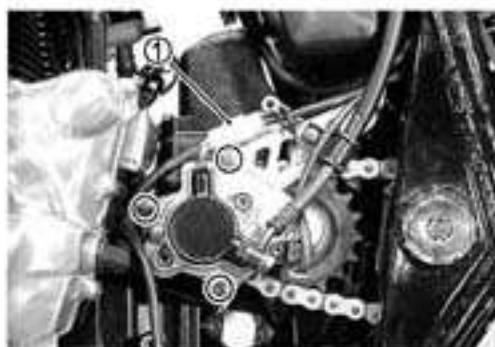

- Remove the clutch push rod ①.
- Remove the speed sensor rotor ②.
- Remove the engine sprocket nut ③ and the washer.

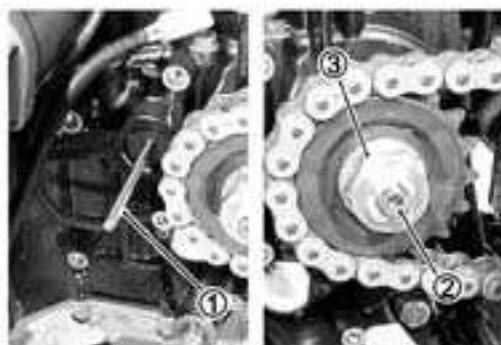

- Remove the cotter pin. (For E-03, 28, 33)
- Loosen the rear axle nut and the rear torque link nut.
- Loosen the left and right chain adjusters.
- Push the rear wheel forward and make sure that the drive chain has enough slack.
- Disengage the drive chain from the rear sprocket.
- Remove the engine sprocket.



### ENGINE MOUNTING

- Support the engine using an engine jack.
- With each engine mounting bolts and nuts removed, detach the frame down tube .



- Draw out the engine mounting shafts and remove the engine assembly from frame.



## ENGINE INSTALLATION

Install the engine in the reverse order of engine removal.

Pay attention to the following points:

### NOTE:

Hang the drive chain on the driveshaft when installing the engine.

### ENGINE MOUNT

- Install the engine and tighten the engine mounting bolts and nuts.

 99000-32050: THREAD LOCK "1342"

### BOLT LENGTH

ITEM	mm	in
①	35	1.4
②	25	0.98
③	14	0.55
④	60	2.4
⑤	50	2.0
⑥	14	0.55
⑦	140	5.5
⑧	155	6.1

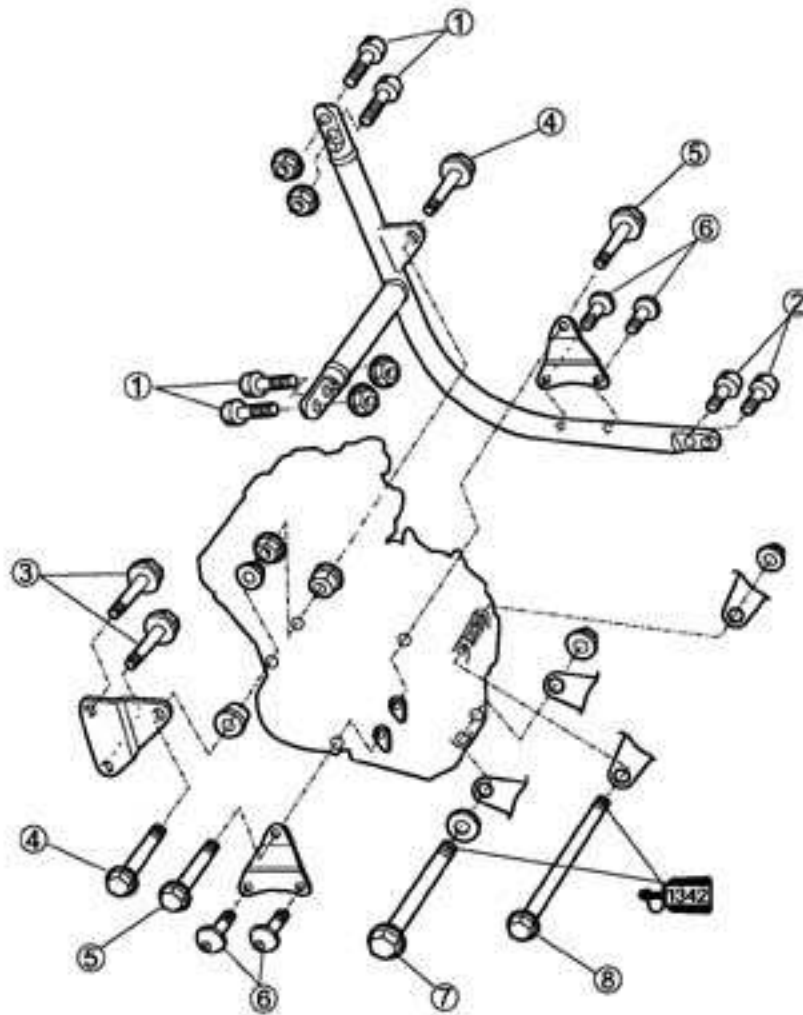

ITEM	N·m	kgf·m	lb·ft
①②③	50	5.0	37
④⑤	55	5.5	41
⑥	23	2.3	17
⑦	88	8.8	65
⑧	85	8.5	63

- Apply a small quantity of **THREAD LOCK** to the drive shaft thread portion and tighten the engine sprocket nut ① to the specified torque.

 **99000-32050: THREAD LOCK "1342"**

 **Engine sprocket nut: 115 N·m (11.5 kgf·m, 83.2 lb-ft)**

- Tighten the speed sensor rotor bolt ② to the specified torque.

 **Speed sensor rotor bolt: 20 N·m (2.0 kgf·m, 14.8 lb-ft)**

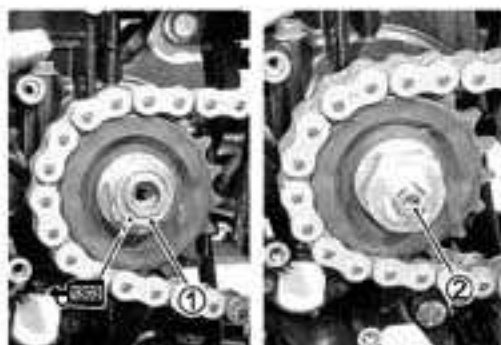

- Apply grease to the clutch push rod and clutch release piston, and install it.

 **99000-25010: SUZUKI SUPER GREASE "A"**

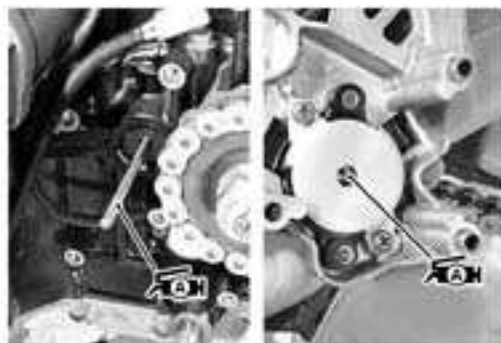

#### CLUTCH RELEASE CYLINDER

- Install the clutch release cylinder housing.

 **Clutch release cylinder housing bolt:**  
**10 N·m (1.0 kgf·m, 7.4 lb-ft)**



#### GEARSHIFT LEVER

- Install the engine sprocket cover and the gearshift lever.

**DATA** Gearshift lever height: 40 – 50 mm (1.6 – 2.0 in)





**EXHAUST PIPE/ MUFFLER**

- Install the exhaust pipes and mufflers as shown in illustration.

**CAUTION**

Replace the gaskets with new ones.

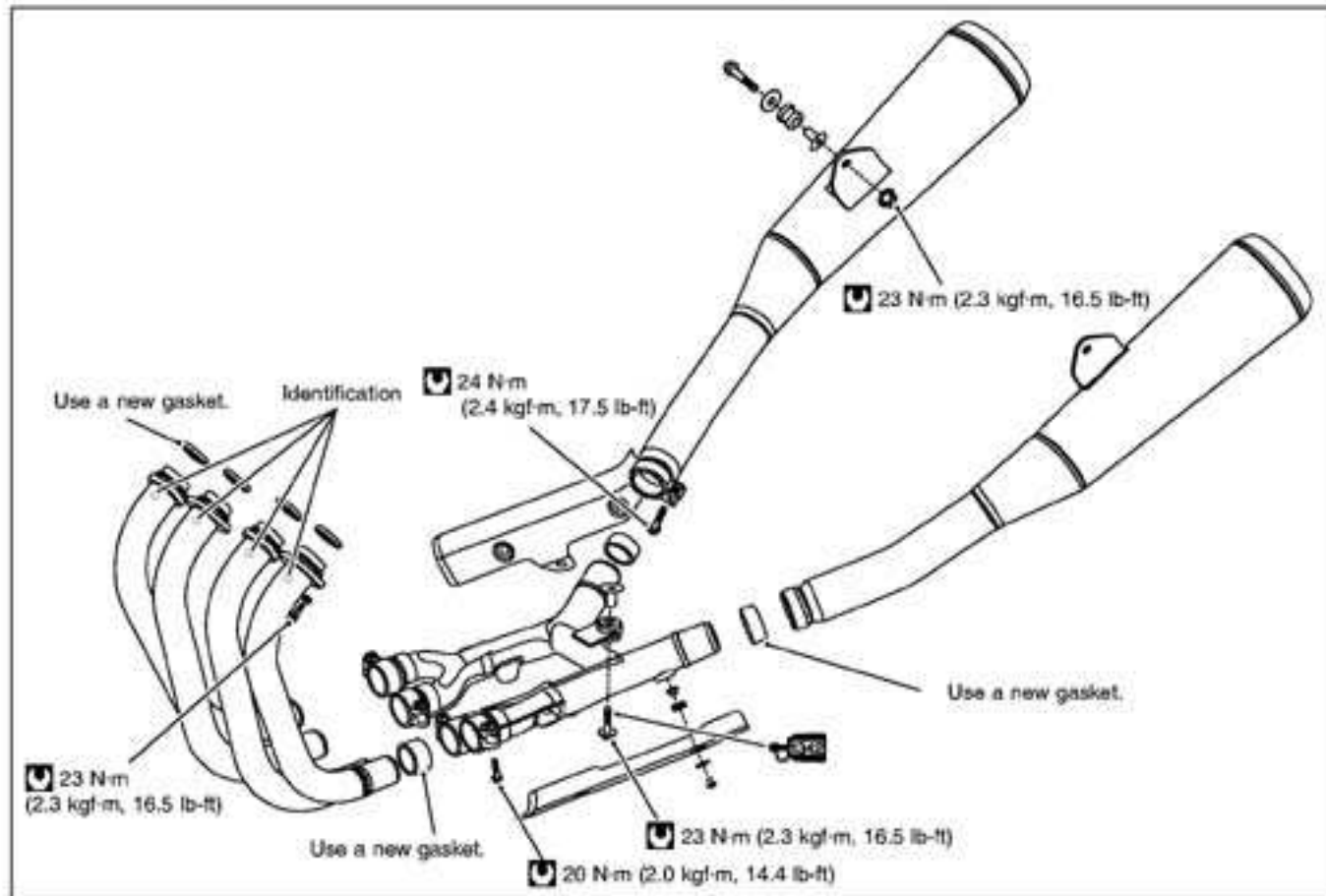
**OIL COOLER**

- Fit a new O-ring.
- Install the oil cooler hoses.

**Oil cooler union bolt: 10 N·m (1.0 kgf·m, 7.4 lb-ft)**



- Install and adjust the following items.
  - \* Engine oil (☞ 2-13)
  - \* Throttle valve synchronization (☞ 4-66)
  - \* Throttle cable play (☞ 2-15)
  - \* Idling adjustment (☞ 2-14)
  - \* Drive chain slack (☞ 2-17)
  - \* Wiring harness, cables and hoses (☞ 8-16 - 29)



## ENGINE DISASSEMBLY

### CAUTION

Identify the position of each removed part. Organize the parts in their respective groups (e.g., intake, exhaust) so that they can be reinstalled in their original positions.

### CYLINDER HEAD COVER

- Remove the PAIR reed valve cover and reed valve.

- Remove the oil hoses.

- Remove the spark plugs. (⚠2-5)
- Remove the cylinder head cover.

- Remove the dowel pins and O-rings.

### SIGNAL GENERATOR COVER

- Remove the signal generator cover and gasket.

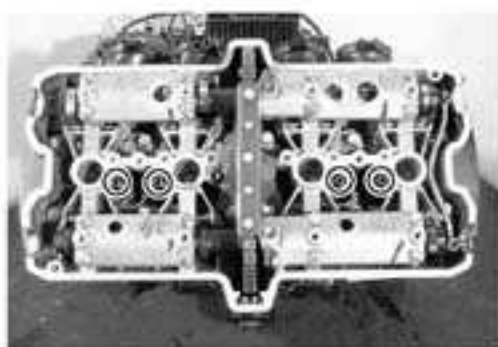
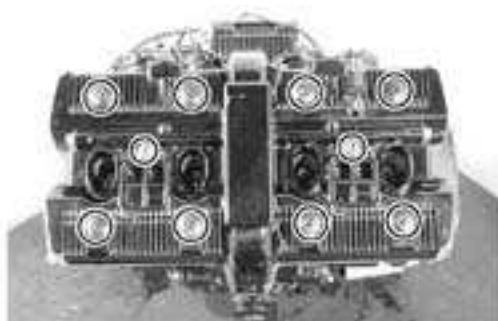
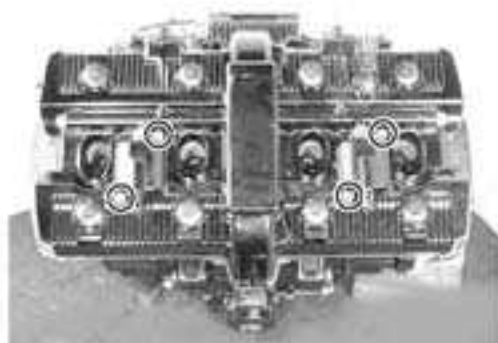

- Set the #1 cylinder at TDC.  
Turn the crankshaft to bring the "T" line on the rotor to the tip of signal generator, and the lines on camshaft facing outside.



- Remove the cam chain tension adjuster cap, the washer, the spring and the steel ball.
- Remove the cam chain tension adjuster.



- Remove the oil pipe ①.
- Remove the cam chain guide ② and camshaft journal holders.

**CAUTION**

Be sure to loosen the camshaft journal holder bolts evenly by shifting the wrench diagonally.

- Remove the intake and exhaust camshafts.

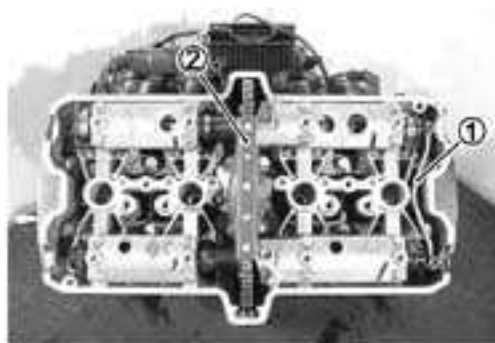

- Remove the cam chain guide.



**CYLINDER HEAD**

- Remove the oil hose.

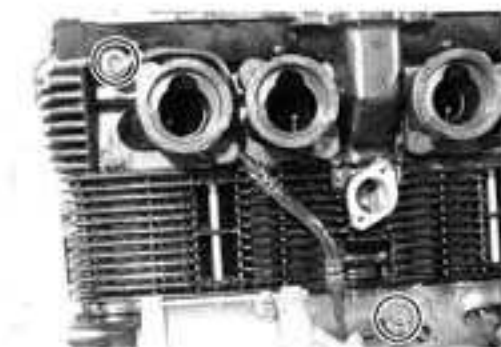

- Loosen the cylinder nut (A).
- Remove the cylinder head bolts (M6).

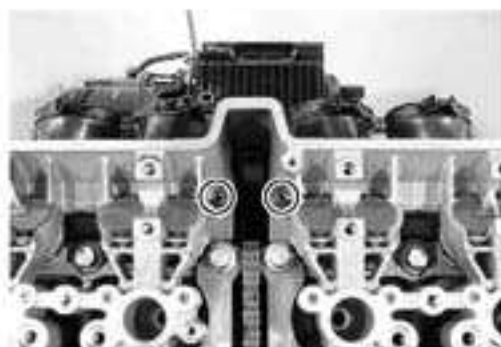

- Remove the cylinder head bolts and nuts.

**NOTE:**

*When loosening the cylinder head bolts and nuts, loosen each bolt little by little diagonally.*

- Remove the cylinder head.

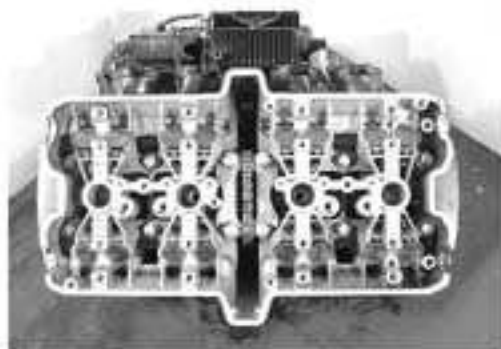
**CYLINDER**

- Draw out the oil return pipes (R, L).
- Remove the cylinder nut (A).



- Remove the cylinder head gasket and dowel pins.
- With both end of cylinder evenly rised, remove the cylinder.



#### PISTON

- Put the rag under the piston so as not to drop the parts into the crankcase, remove the piston pin circlip.
- Draw out the piston pin, remove the piston.



- Remove the gasket and dowel pins.

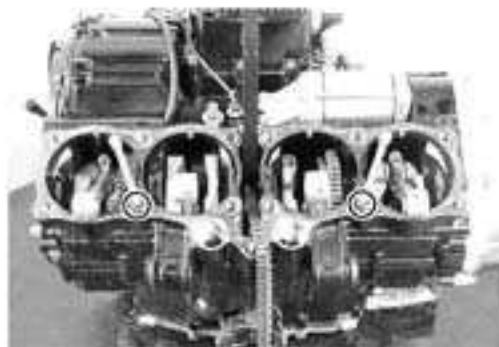

#### OIL TEMPERATURE SENSOR

- Remove the oil temperature sensor ①.

#### STARTER MOTOR

- Remove the starter motor.



#### BREATHER COVER

- Remove the breather cover.

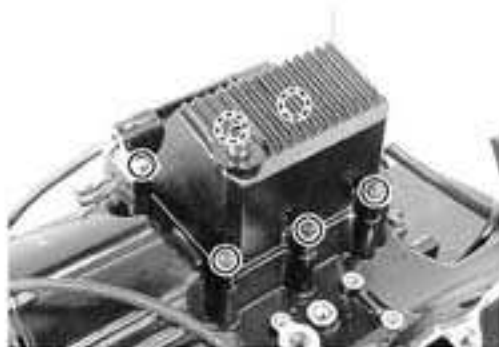

**SIGNAL GENERATOR**

- With the rotor held, remove the signal generator rotor bolt.



- Remove the signal generator.
- Remove the oil pressure switch ①.

**OIL FILTER**

- Remove the oil filter.

 09915-40610: Oil filter wrench

**COOLING FAN SWITCH**

- Remove the cooling fan switch.



**CLUTCH**

- Remove the clutch cover.



- With the clutch spring bolts removed, detach the clutch springs and clutch pressure plate.



- Remove the clutch push piece ①, the bearing ② and the thrust washer ③.
- Remove the clutch push rod ④.

**NOTE:**

*If it is difficult to pull out the push rod ④, use a magnetic hand or a wire.*

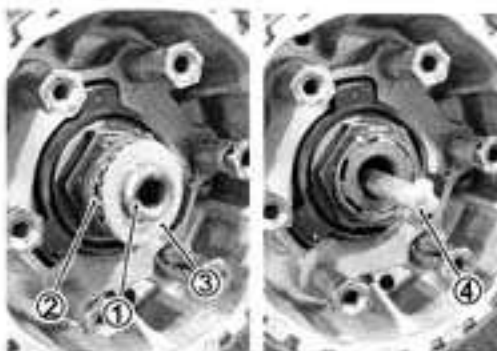

- Remove the clutch drive plates and the driven plates.
- Remove the spring washer and the spring washer seat.
- Unlock the clutch sleeve hub nut.

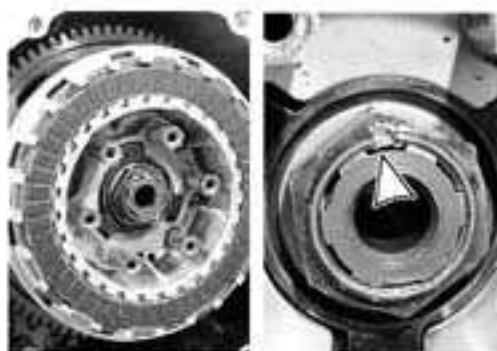

- Hold the clutch sleeve hub with the special tool.

 09920-53740: Clutch sleeve hub holder

- Remove the clutch sleeve hub nut.

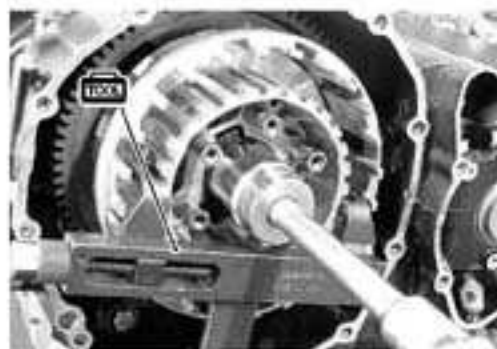



- Remove the wave washer ①, the back torque limiter ② and the clutch sleeve hub.



- Remove the washer ③ and the primary driven gear assembly.
- Remove the spacer, the bearing and the washer.



#### OIL PUMP DRIVEN GEAR

- Remove the circlip ① and the washer ②.
- Remove the oil pump driven gear.

#### NOTE:

Do not drop the circlip, the pin and the washer into the crankcase.

- Remove the pin ③ and the washer ④.

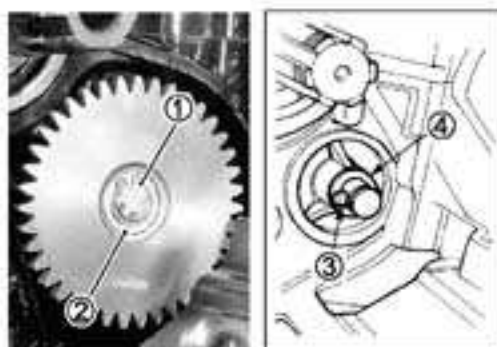

#### GEARSHIFT SHAFT

- With the circlip removed, remove the gearshift shaft assembly.

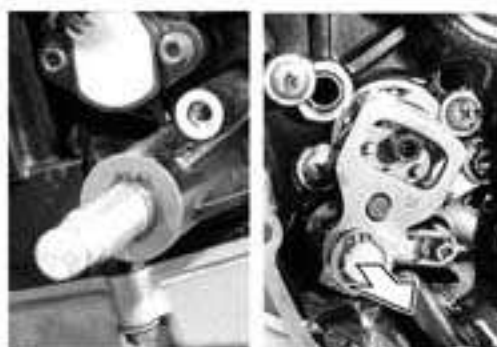

- Remove the gearshift cam plate ① and the gearshift cam stopper ②.

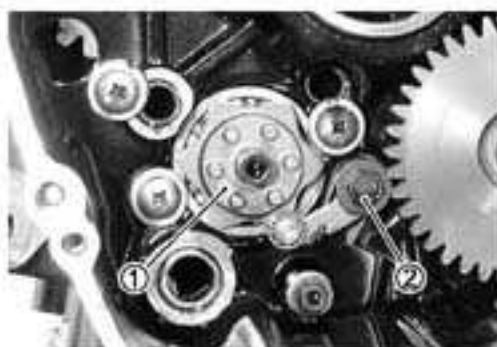



### GENERATOR COVER

- Remove the generator cover.



- Remove the starter idle gear and its shaft.



### GENERATOR ROTOR/STARTER CLUTCH

- Hold the generator rotor with the special tool and remove the generator rotor bolt.

 09930-44530: Rotor holder



- Remove the generator rotor with the special tool.

 09930-30450: Rotor remover  
09930-44530: Rotor holder

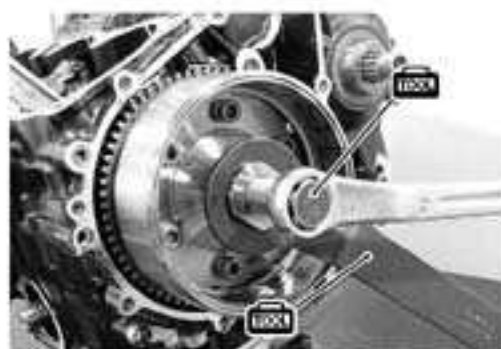

### GEAR POSITION SENSOR

- Remove the gear position sensor.
- Remove the switch contacts and the springs.

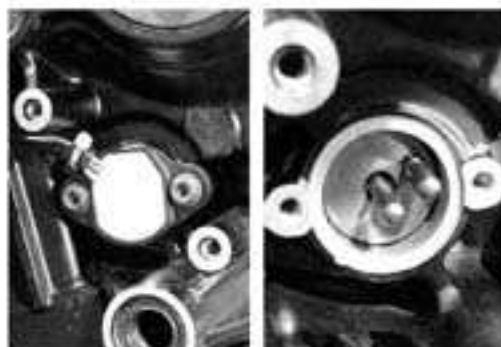

**OIL PAN**

- Remove the oil pan.

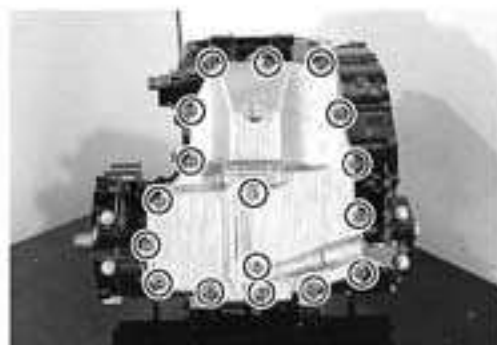

- Remove the oil pressure regulator.

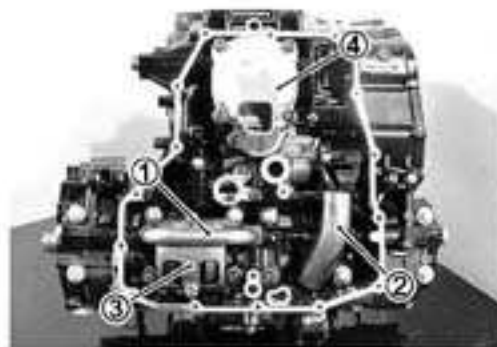

- Remove the oil pipes, ① and ②.
- Remove the crank balancer guard ③.
- Remove the oil strainer ④ and its O-ring.

**CRANK BALANCER**

- With the balancer lever bolt removed, draw out the crank balancer shaft and remove the crank balancer.

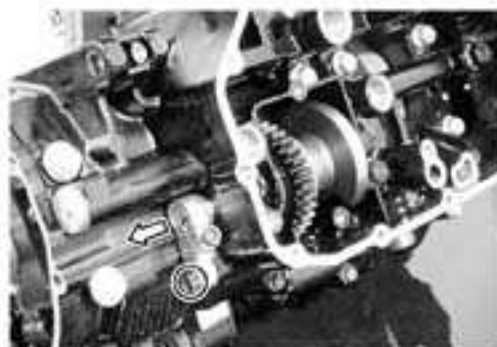

### CRANK CASE

- Remove the lower crankcase bolts, (6 mm) and (8 mm).

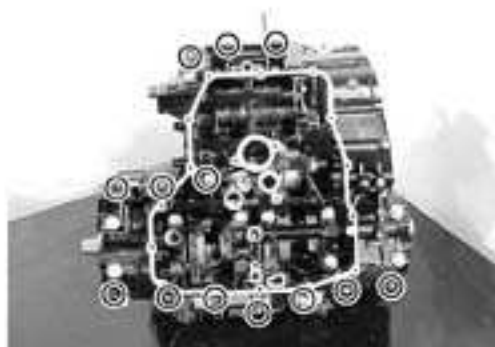

- Remove the upper crankcase bolts, (6 mm) and (8 mm).

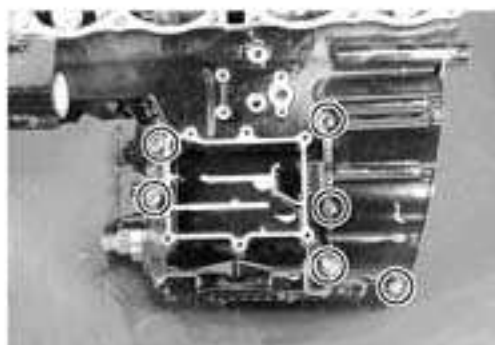

- Remove the crank journal bolts (9 mm).

#### NOTE:

*Loosen the crank journal bolts in the descending order of the number on crankcase.*

- Remove the lower crankcase.



### GEARSHIFT CAM AND GEARSHIFT FORK

- With the screws removed, draw out the gearshift fork shaft and remove the gearshift fork.



### OIL PUMP

- Remove the oil pump.

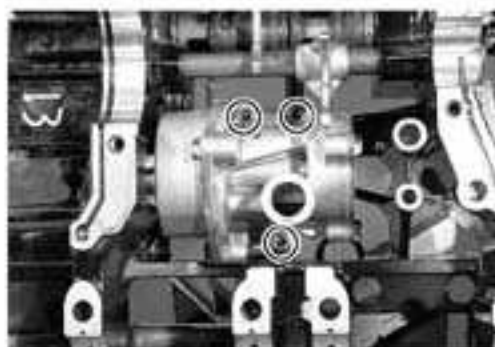

- Remove the O-rings and the dowel pins.

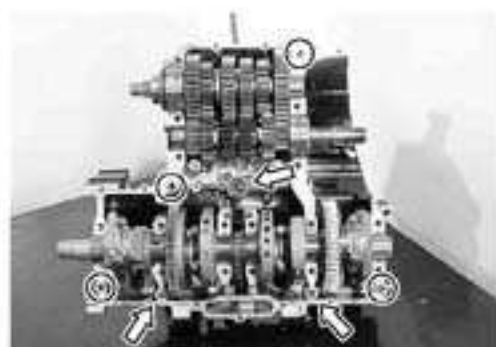

### CRANKSHAFT

- Remove the crankshaft thrust bearings ①.
- Remove the crankshaft together with the cam chain.



### TRANSMISSION

- Remove the countershaft and the driveshaft.



- Remove the C-ring ② and the dowel pins ③.



## ENGINE COMPONENTS INSPECTION AND SERVICE

### CAUTION

Identify the position of each removed part. Organize the parts in their respective groups (i.e., intake, exhaust, No.1 or No.2) so that they can be installed in their original locations.

### PAIR VALVE

#### REMOVAL AND INSTALLATION

- Remove the fuel tank. (☞ 4-32)
- Disconnect the PAIR valve hoses and remove the PAIR valve.

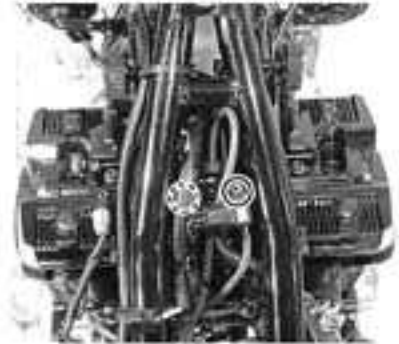

#### INSPECTION

##### PAIR REED VALVE HOSE

- Inspect the PAIR valve hose for damage and connection.

##### PAIR REED VALVE

- Inspect the reed valve for the carbon deposit.
- If the carbon deposit is found in the reed valve, replace the PAIR control valve with a new one.



##### PAIR CONTROL VALVE

- Inspect that air flows through the PAIR control valve air inlet port to the air outlet ports.
- If air does not flow out, replace the PAIR valve with a new one.

- Connect the vacuum pump gauge to the vacuum port of the control valve as shown in the photograph.
- Apply negative pressure slowly to the control valve and inspect the air flow.
- If air does not flow out, the control valve is in normal condition.
- If the control valve does not function within the specification, replace the control valve with a new one.

##### Negative pressure range

(Standard): 38.7 – 53.3 kPa (280 – 390 mmHg)

 09917-47010: Vacuum pump gauge

### CAUTION

Use a hand operated vacuum pump gauge to prevent the control valve damage.



## CYLINDER HEAD COVER

### CAM POSITION SENSOR

- Inspect the cam position sensor for abnormal condition.
- With the grease applied to the O-ring, install the cam position sensor.

 Cam position sensor bolt: 10 N·m (1.0 kgf·m, 7.4 lb-ft)

 99000-25010: SUZUKI SUPER GREASE "A"



### OIL GALLERY PLUG

- Install the gasket and the oil gallery plug.

 Oil gallery plug: 14 N·m (1.4 kgf·m, 10 lb-ft)



## CAMSHAFT

### CAMSHAFT IDENTIFICATION

The exhaust camshaft can be distinguished from that of the intake by the embossed letters "EX" (for exhaust) as against letters "IN" (for intake).



### CAM WEAR

- Check the camshaft for wear or damage.
- Measure the cam height  $\text{H}$  with a micrometer.

 09900-20202: Micrometer (25 – 50 mm)

**DATA** Cam height  $\text{H}$ :

Service Limit: (IN.) : 34.98 mm (1.378 in)

(EX.) : 33.88 mm (1.339 in)

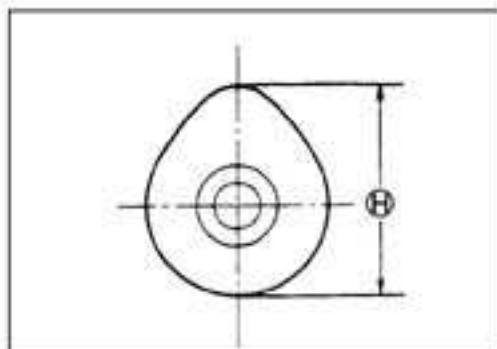

### CAMSHAFT RUNOUT

- Measure the runout using the dial gauge.
- Replace the camshaft if the runout exceeds the limit.

 09900-20606: Dial gauge (1/100 mm)

09900-20701: Magnetic stand

09900-21304: V-block set (100 mm)

**DATA** Camshaft runout:

Service Limit (IN & EX): 0.10 mm (0.004 in)

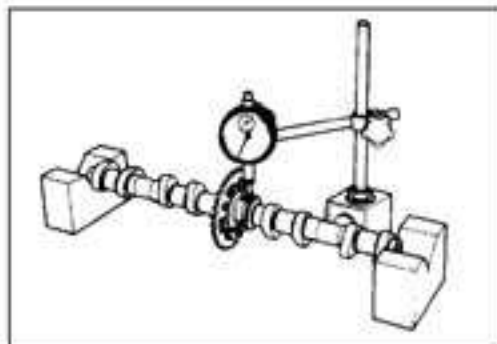

**CAMSHAFT JOURNAL WEAR**

- Determine whether or not each journal is worn down to the limit by measuring the oil clearance with the camshaft installed in place.
- Use the plastigauge to read the clearance at the widest portion, which is specified as follows:

**DATA** Camshaft journal oil clearance:

Standard: (IN & EX): 0.032 – 0.066 mm  
(0.0013 – 0.0026 in)

Service Limit: (IN & EX): 0.150 mm (0.0059 in)

**TOOL** 09900-22301: Plastigauge  
09900-22302: Plastigauge

- Tighten the camshaft journal holder bolts evenly and diagonally to the specified torque.

**U** Camshaft journal holder bolt: 10 N·m (1.0 kgf·m, 7.4 lb·ft)

**NOTE:**

*Do not rotate the camshaft with the plastigauge in place.*

- Remove the camshaft holders, and read the width of the compressed plastigauge with envelope scale.
- This measurement should be taken at the widest part.

- If the camshaft journal oil clearance measured exceeds the limit, measure the inside diameter of the camshaft journal holder and outside diameter of the camshaft journal.
- Replace the camshaft or the cylinder head depending upon which one exceeds the specification.

**DATA** Journal holder I.D.:

Standard: (IN & EX): 24.012 – 24.025 mm  
(0.9454 – 0.9459 in)

**TOOL** 09900-20602: Dial gauge (1/1000, 1 mm)  
09900-22403: Small bore gauge (18 – 35 mm)

**DATA** Camshaft journal O.D.:

Standard (IN & EX): 23.959 – 23.980 mm  
(0.9433 – 0.9441 in)

**TOOL** 09900-20205: Micrometer (0 – 25 mm)

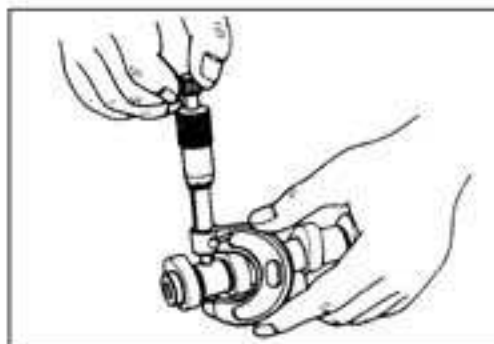
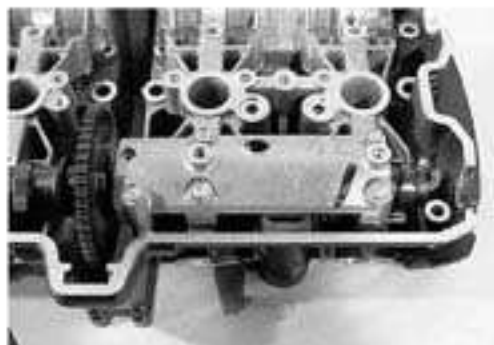



**CAM SPROCKET**

- Inspect the sprocket teeth for wear.
- If they are worn, replace the sprocket/camshaft assembly and cam chain as a set.
- Install the cam sprocket to the camshaft. (☞3-75)
- Apply a small quantity of thread lock to the cam sprocket bolt and tighten it to the specified torque.

 99000-32030: THREAD LOCK "1303"

 Cam sprocket bolt: 25 N·m (2.5 kgf·m, 18 lb-ft)

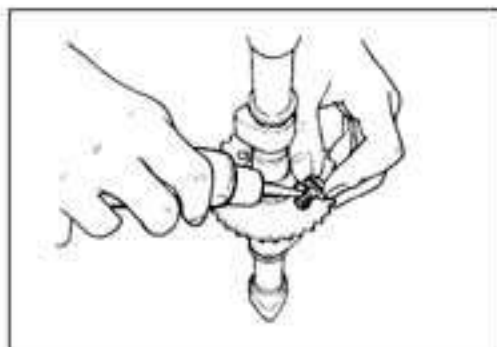
**CAM CHAIN TENSION ADJUSTER****INSPECTION**

- Remove the cam chain tension adjuster cap bolt.
- Check that the push rod slides smoothly when releasing stopper.
- If it does not slide smoothly, replace the cam chain tension adjuster with a new one.

**CAM CHAIN TENSIONER****INSPECTION**

- Check the contacting surface of the cam chain tensioner.
- If it is worn or damaged, replace it with a new one.

**CAM CHAIN GUIDE****INSPECTION**

- Check the contacting surfaces of the cam chain guides.
- If they are worn or damaged, replace them with the new ones.

## CYLINDER HEAD AND VALVE

### VALVE AND VALVE SPRING DISASSEMBLY

- Remove the tappets and shims by fingers or magnetic hand.

#### CAUTION

Identify the position of each removed part.

- Using special tools, compress the valve springs and remove the two cotter halves ① from valve stem.

-  09916-14510: Valve lifter
- 09916-14521: Valve lifter attachment (24 mm)
- 09916-84511: Tweezers

#### CAUTION

Be careful not to damage the tappet sliding surface with the special tool.

- Remove the valve spring retainer ② and valve springs ③.
- Pull out the valve ④ from the other side.
- Remove the spring seat ⑤.

- Remove the oil seal ⑥.

#### CAUTION

Do not reuse the removed oil seal.

### CYLINDER HEAD DISTORTION

- Decarbonize the combustion chambers.
- Check the gasket surface of the cylinder head for distortion with a straightedge and thickness gauge, taking a clearance reading at several places indicated.
- If the largest reading at any position of the straightedge exceeds the limit, replace the cylinder head.

-  09900-20803: Thickness gauge

- DATA** Cylinder head distortion:  
Service Limit: 0.20 mm (0.008 in)

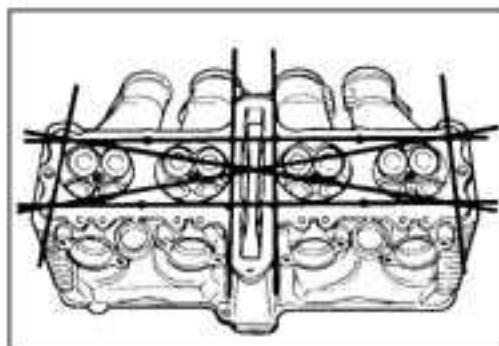
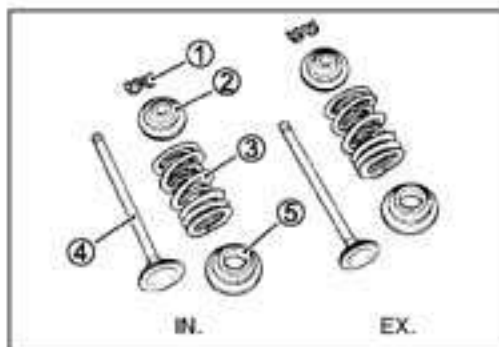
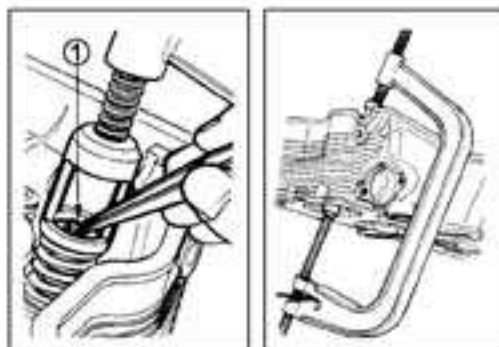
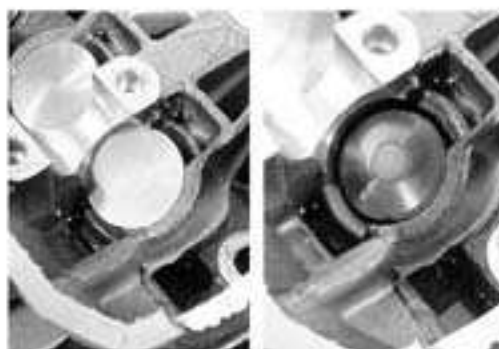

**VALVE STEM DEFLECTION**

- Lift the valve about 10 mm (0.39 in) from the valve seat.
- Measure the valve stem deflection in two directions, perpendicular to each other, by positioning the dial gauge as shown.
- If the deflection measured exceeds the limit, then determine whether the valve or the guide should be replaced with a new one.

**TOOL** 09900-20606: Dial gauge (1/100 mm)  
09900-20701: Magnetic stand

**DATA** Valve stem deflection (IN & EX):  
Service Limit: 0.35 mm (0.014 in)

**VALVE STEM WEAR**

- If the valve stem is worn down to the limit, as measured with a micrometer, replace the valve.
- If the stem is within the limit, then replace the guide.
- After replacing valve or guide, be sure to recheck the deflection.

**TOOL** 09900-20205: Micrometer (0 – 25 mm)

**DATA** Valve stem O.D.:  
Standard (IN) : 4.475 – 4.490 mm (0.1762 – 0.1768 in)  
(EX): 4.455 – 4.470 mm (0.1754 – 0.1760 in)

**NOTE:**

If valve guides have to be removed for replacement after inspecting related parts, carry out the steps shown in valve guide servicing. (☞ 3-29)

**VALVE STEM RUNOUT**

- Support the valve using V-blocks and check its runout using the dial gauge as shown.
- If the runout exceeds the service limit, replace the valve.

**TOOL** 09900-21304: V-block set (100 mm)

**DATA** Valve stem runout: Service Limit: 0.05 mm (0.002 in)

**VALVE HEAD RADIAL RUNOUT**

- Place the dial gauge at a right angle to the valve head face and measure the valve head radial runout.
- If it measures more than the service limit, replace the valve.

**DATA** Valve head radial runout:  
Service Limit: 0.03 mm (0.001 in)

**VALVE FACE WEAR**

- Visually inspect each valve face for wear. Replace any valve with an abnormally worn face. The thickness of the valve face decreases as the face wears. Measure the valve face  $\text{①}$ . If it is out of specification, replace the valve with a new one.

**TOOL** 09900-20102: Vernier callipers

**DATA** Valve head thickness  $\text{①}$ : Service Limit: 0.5 mm (0.02 in)

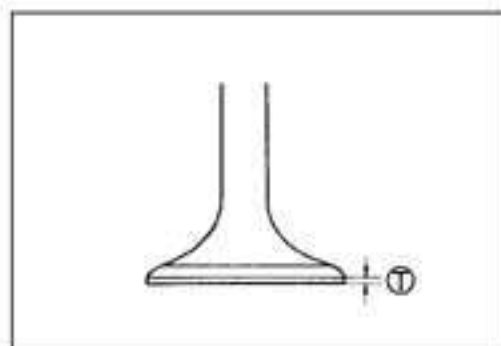
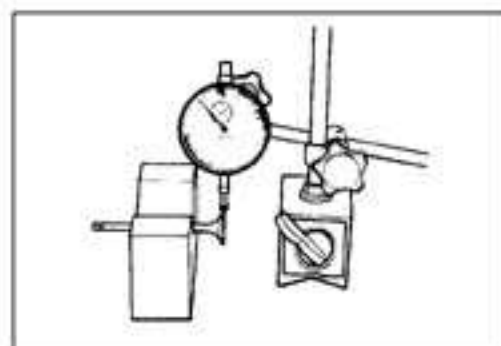
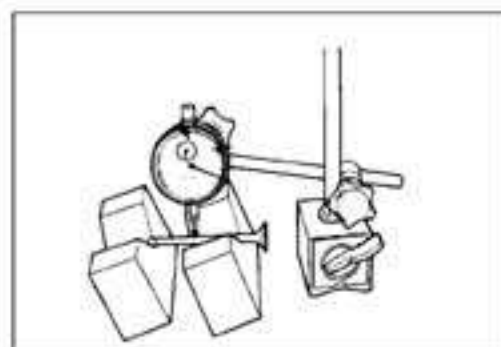
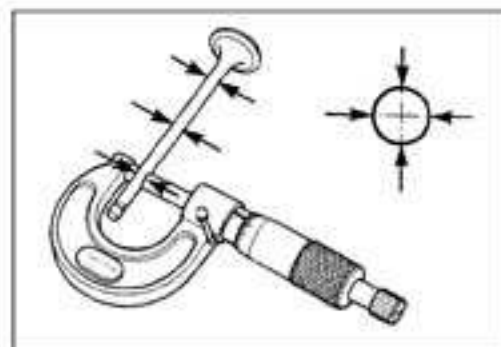
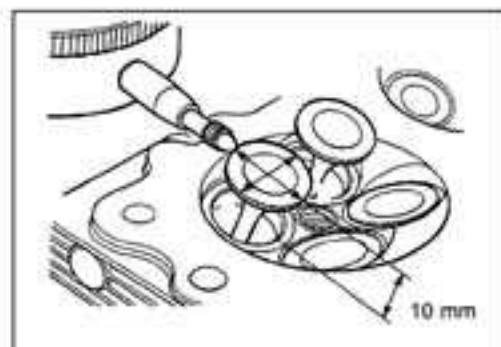

**VALVE SPRING**

The force of the coil springs keeps the valve seat tight. Weakened springs result in reduced engine power output, and often account for the chattering noise coming from the valve mechanism.

- Check the valve springs for proper strength by measuring their free length and also by the force required to compress them.
- If the spring length is less than the service limit, or if the force required to compress the spring does not fall within the range specified, replace both the inner and outer springs as a set.

 09900-20102: Vernier calipers

**DATA** Valve spring free length (IN & EX): Service limit:

Inner: 38.6 mm (1.52 in)

Outer: 40.6 mm (1.60 in)

**DATA** Valve spring tension (IN & EX): Standard:

Inner: 49 – 59 N, 4.9 – 5.9 kgf/ 29.9 mm  
(10.8 – 13.0 lbs/ 1.18 in)

Outer: 136 – 156 N, 13.6 – 15.6 kgf/ 33.4 mm  
(30.0 – 34.4 lbs/ 1.31 in)

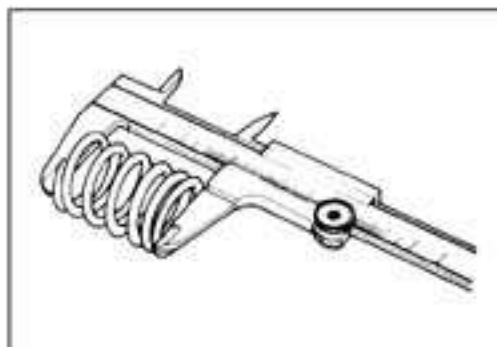

**VALVE GUIDE SERVICING**

- Using the valve guide remover, drive the valve guide out toward the intake or exhaust camshaft side.

 **09916-53310: Valve guide remover/installer**

**NOTE:**

- Discard the removed valve guide subassemblies.
- Only oversized valve guides are available as replacement parts. (Part No. 11115-18D72)

- Refinish the valve guide holes in cylinder head with the reamer and handle.

 **09916-34561: Valve guide reamer**  
**09916-34542: Reamer handle**

**CAUTION**

When refinishing or removing the reamer from the valve guide hole, always turn it clockwise.

- Apply engine oil to the valve guide hole.
- Drive the valve guide into the hole using the special tool.

 **09916-43210: Valve guide installer/remover**

**NOTE:**

Install the valve guide until the ring  contacts with the cylinder head.

**CAUTION**

Failure to oil the valve guide hole before driving the new guide into place may result in a damaged guide or head.

- After installing the valve guides, refinish their guiding bores using the reamer.
- Clean and oil the guides after reaming.

 **09916-33310: Valve guide reamer**  
**09916-34542: Valve guide reamer handle**

**NOTE:**

Insert the reamer from the combustion chamber and always turn the reamer handle clockwise.

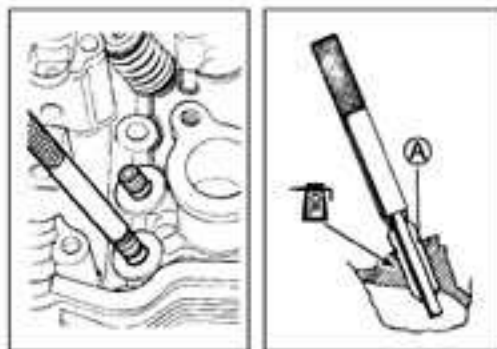
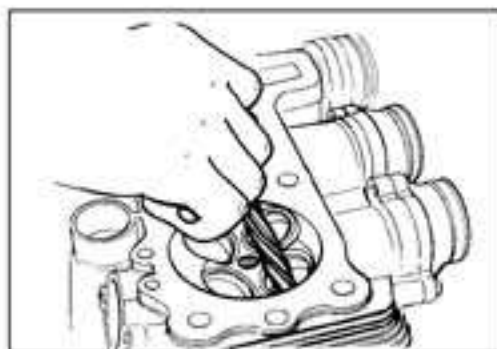

**VALVE SEAT WIDTH INSPECTION**

- Visually check for valve seat width on each valve face.
- If the valve face has worn abnormally, replace the valve.
- Coat the valve seat with Prussian Blue and set the valve in place. Rotate the valve with light pressure.
- Check that the transferred blue on the valve face is uniform all around and in center of the valve face.

**TOOL 09916-10911: Valve rapper set**

- If the seat width  $\text{W}$  measured exceeds the standard value, or seat width is not uniform reface the seat using the seat cutter.

**DATA Valve seat width  $\text{W}$ :**

Standard: 0.9 – 1.1 mm (0.035 – 0.043 in)

If the valve seat is out of specification, recut the seat.

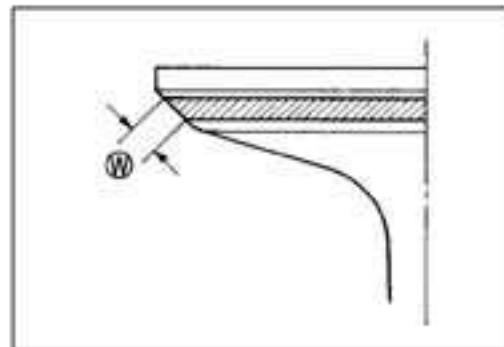
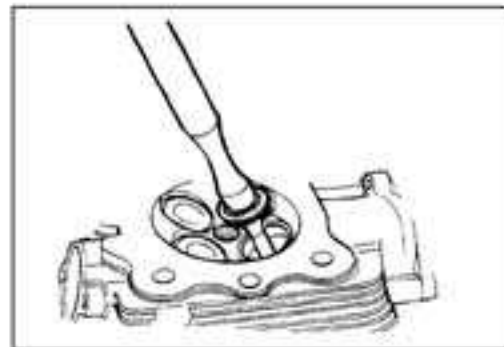
**VALVE SEAT SERVICING**

- The valve seats for both the intake and exhaust valves are machined to four different angles. The seat contact surface is cut at 45°.

	INTAKE	EXHAUST
15°		N-121
30°	N-126	
45°	N-122	N-122
60°	N-111	

- TOOL 09916-21111: Valve seat cutter set**
- 09916-20630: Valve seat cutter (N-126)
- 09916-20640: Solid pilot (N-100-4.5)

**NOTE:**

The valve seat cutters (N-121), (N-122) and (N-111) are included in the valve seat cutter set (09916-21111).

**CAUTION**

The valve seat contact area must be inspected after each cut.

- When installing the solid pilot ①, rotate it slightly.

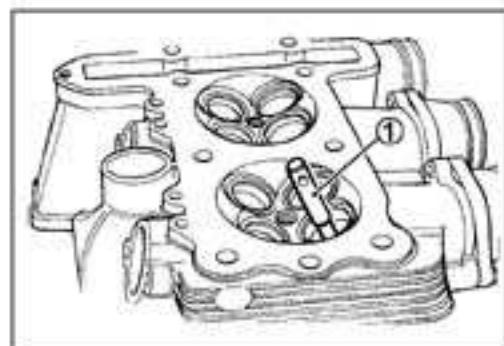
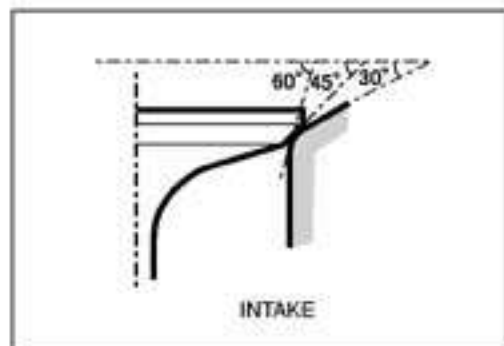
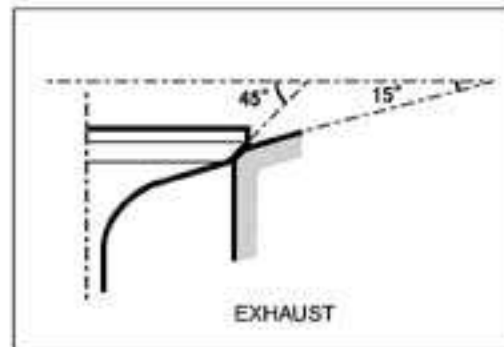

**INITIAL SEAT CUT**

- Install the 45° cutter ②, attachment ③ and T-handle ④.

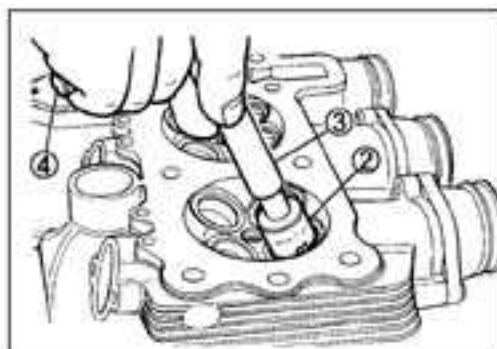

- Using the 45° cutter, descale and clean up the seat. Rotate the cutter one or two turns.
- Measure the valve seat width  $\text{W}$  after every cut.

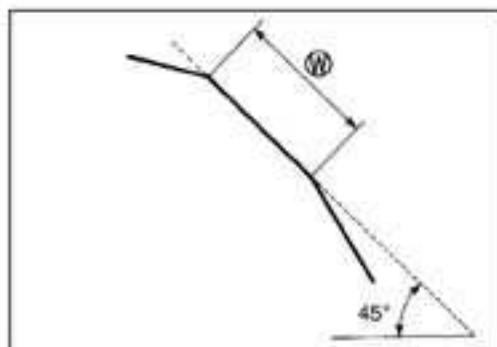

- If the valve seat is pitted or burned, use the 45° cutter to condition the seat some more.

**NOTE:**

*Cut only the minimum amount necessary from the seat to prevent the possibility of the valve stem becoming too close to the camshaft.*

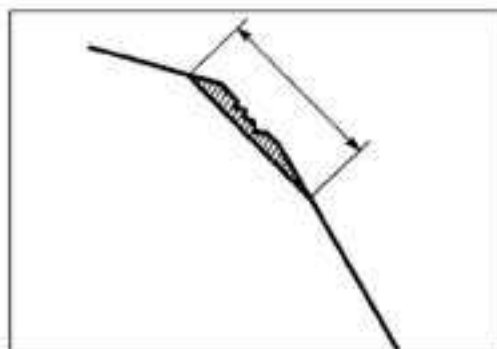
**TOP NARROWING CUT**

- If the contact area  $\text{W}$  is too high on the valve, or if it is too wide, use the 15° (for the exhaust side) and the 30° (for the intake side) to lower and narrow the contact area.

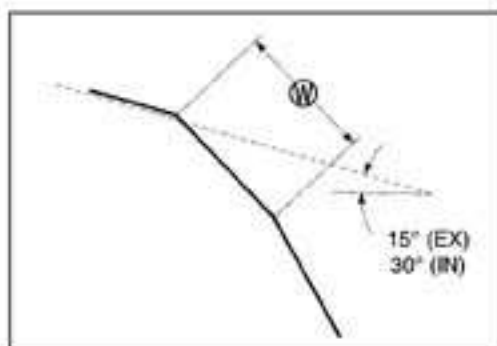
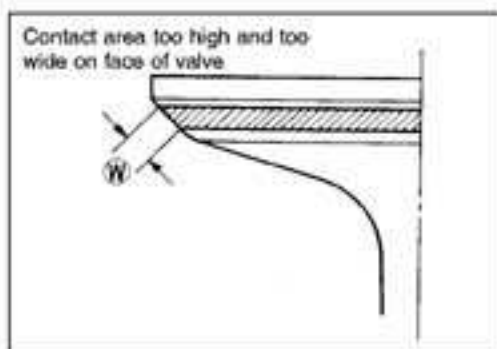



**BOTTOM NARROWING CUT (IN.)**

- If the contact area  $\textcircled{W}$  is too wide or too low, use the 60° cutter to narrow and raise the contact area.

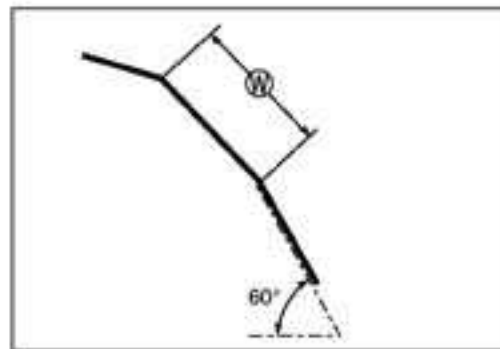
**FINAL SEAT CUT**

- If the contact area  $\textcircled{W}$  is too low or too narrow, use the 45° cutter to raise and widen the contact area.

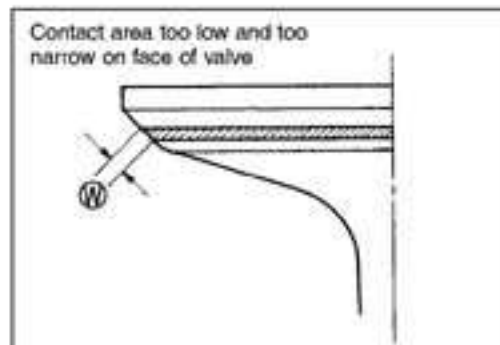
**NOTE:**

After cutting the 15°, 30° and 60° angles, it is possible that the valve seat (45°) is too narrow. If so, recut the valve seat to the correct width.

- After the desired seat position and width is achieved, use the 45° cutter very lightly to clean up any burrs caused by the previous cutting operations.

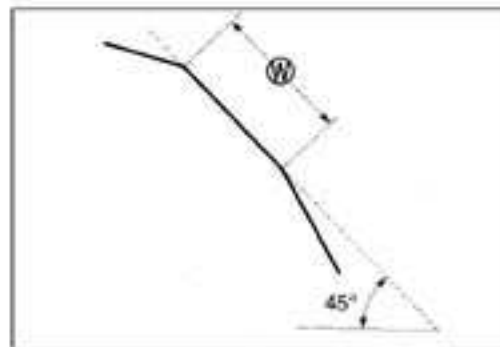
**CAUTION**

Do not use lapping compound after the final cut is made. The finished valve seat should have a velvety smooth finish but not a highly polished or shiny finish. This will provide a soft surface for the final seating of the valve which will occur during the first few seconds of engine operation.

**NOTE:**

After servicing the valve seats, be sure to check the valve clearance after the cylinder head has been reinstalled. (☞ 2-6)

- Clean and assemble the head and valve components. Fill the intake and exhaust ports with gasoline to check for leaks.
- If any leaks occur, inspect the valve seat and face for burrs or other things that could prevent the valve from sealing.

**▲ WARNING**

Always use extreme caution when handling gasoline.

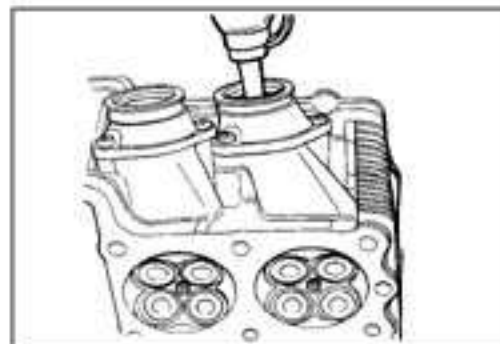

**VALVE AND VALVE SPRING REASSEMBLY**

- Apply molybdenum oil solution to each oil seal, and press-fit them into position with the valve guide installer.

 09916-43210: Valve guide remover/installer

 MOLYBDENUM OIL SOLUTION

**CAUTION**

Do not reuse the removed oil seals.

- Insert the valves, with their stems coated with molybdenum oil solution all around and along the full stem length without any break.

**CAUTION**

When inserting each valve, take care not to damage the lip of the oil seal.

 MOLYBDENUM OIL SOLUTION

- Install the valve springs with the small-pitch portion facing cylinder head.

Ⓐ: Small-pitch portion

Ⓑ: Large-pitch portion

- Put on the valve spring retainer, and using the valve lifter, press down the springs, fit the cotter halves to the stem end, and release the lifter to allow the cotter ① to wedge in between retainer and stem. Be sure that the rounded lip Ⓐ of the cotter fits snugly into the groove Ⓑ in the stem end.

 09916-14510: Valve lifter

09916-14521: Valve lifter attachment (24 mm)

09916-84511: Tweezers

**CAUTION**

Be sure to restore each spring and valve to their original positions.

- Install the tappet shims and the tappets to their original position.

**NOTE:**

- Apply engine oil to the shim and tappet before fitting them.
- When seating the tappet shim, be sure the figure printed surface faces the tappet.

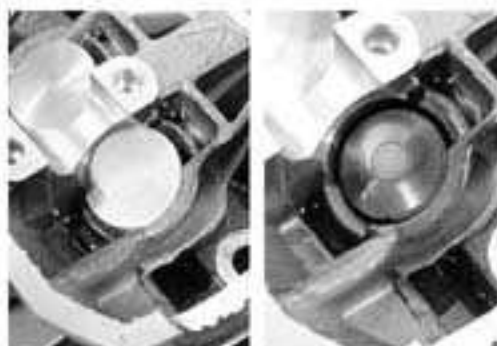
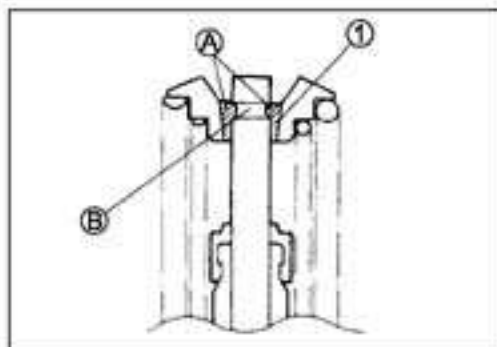
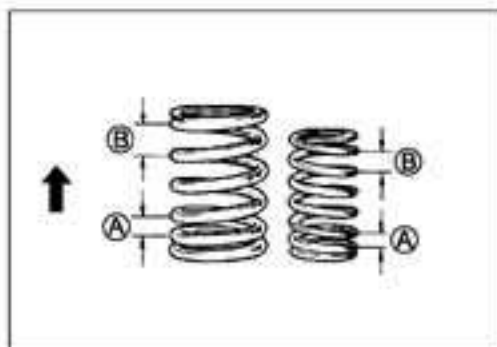
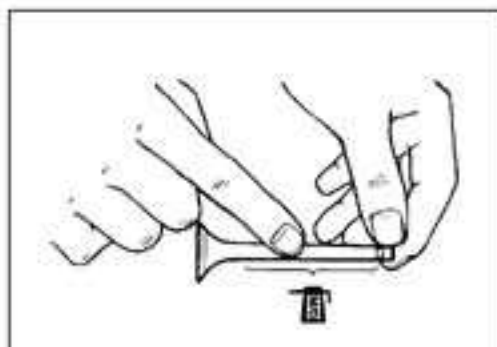

**OIL GALLERY**

- Install the washer and the oil gallery plug.

 Oil gallery plug: 20 N·m (2.0 kgf·m, 15 lb·ft)

**INTAKE PIPE**

- Install the intake pipes.

**CYLINDER****CYLINDER DISTORTION**

- Check the gasket surface of the cylinder for distortion with a straightedge and thickness gauge, taking a clearance reading at several places as indicated.
- If the largest reading at any position of the straightedge exceeds the limit, replace the cylinder.

 09900-20803: Thickness gauge

**DATA** Cylinder distortion:  
Service Limit: 0.20 mm (0.008 in)

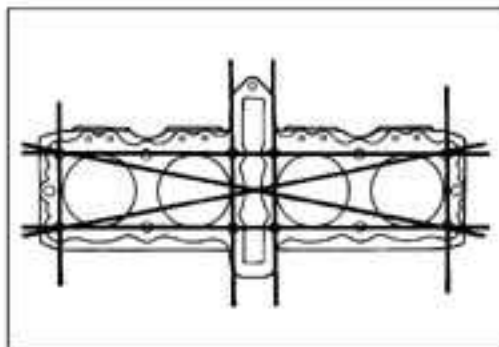
**CYLINDER BORE**

- Inspect the cylinder wall for any scratches, nicks or other damage.
- Measure the cylinder bore diameter at six places.

**DATA** Cylinder bore:  
Standard: 81.000 – 81.015 mm (3.1890 – 3.1896 in)

 09900-20508: Cylinder gauge set

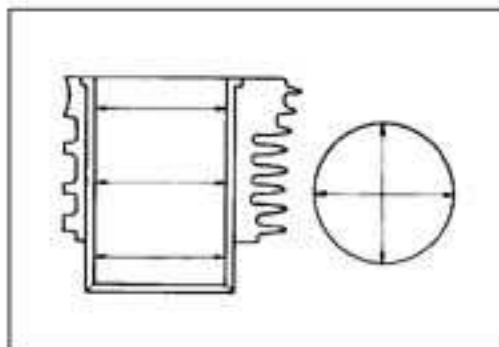
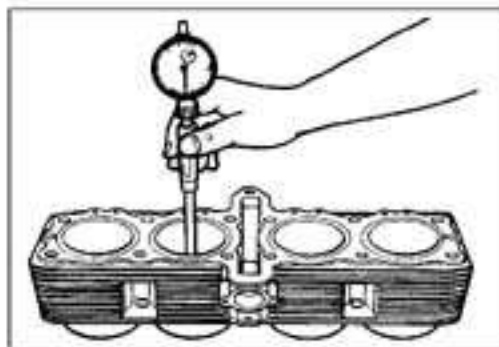

## PISTON AND PISTON RING

### PISTON DIAMETER

- Using a micrometer, measure the piston outside diameter at 15 mm (0.6 in) from the piston skirt end.
- If the measurement is less than the limit, replace the piston.

#### **DATA** Piston diameter:

Standard: 80.980 – 80.995 mm (3.1882 – 3.1888 in)

Service Limit: 80.880 mm (3.1843 in)

at 15 mm (0.6 in) from the skirt end

 09900-20204: Micrometer (75 – 100 mm)

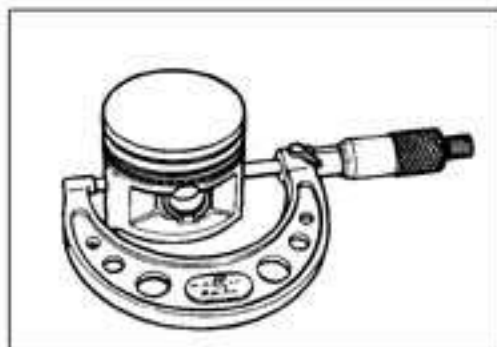
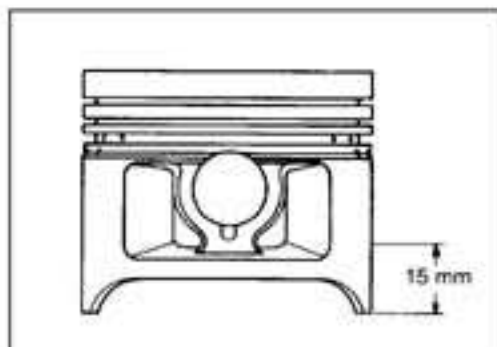

### PISTON TO CYLINDER CLEARANCE

- Subtract the piston diameter from the cylinder bore diameter.
- If the piston to cylinder clearance exceeds the service limit, replace the cylinder and the piston.

#### **DATA** Piston to cylinder clearance:

Standard: 0.015 – 0.025 mm (0.00059 – 0.00098 in)

Service Limit: 0.120 mm (0.0047 in)

### PISTON PINS AND PIN BORE

- Measure the piston pin bore inside diameter using the small bore gauge.
- If the measurement is out of specification, replace the piston.

 09900-20602: Dial gauge (1/1000 mm)

09900-22401: Small bore gauge (10 – 18 mm)

#### **DATA** Piston pin bore I.D.:

Service Limit: 18.030 mm (0.7098 in)

- Measure the piston pin outside diameter at three positions using the micrometer.
- If any of the measurements are out of specification, replace the piston pin.

 09900-20205: Micrometer (0 – 25 mm)

#### **DATA** Piston pin O.D.:

Service Limit: 17.980 mm (0.7079 in)

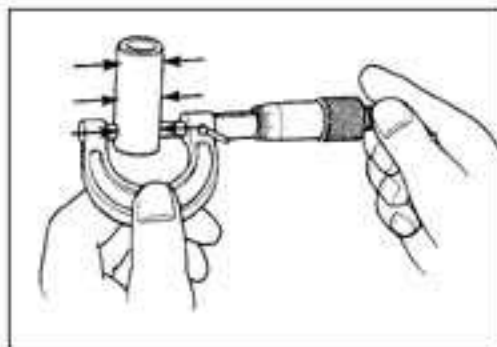
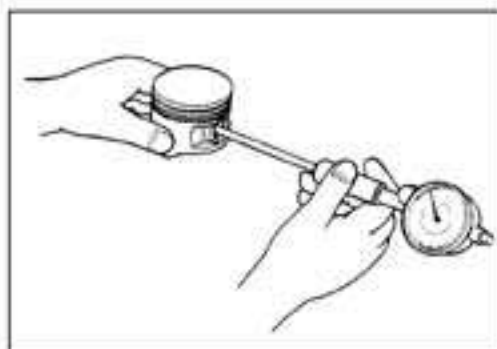

**PISTON RING TO GROOVE CLEARANCE**

- Measure the side clearances of the 1st and 2nd piston rings using the thickness gauge.
- If any of the clearances exceed the limit, replace both the piston and piston rings.

**TOOL** 09900-20803: Thickness gauge  
09900-20205: Micrometer (0 – 25 mm)

**DATA** Piston ring to groove clearance:  
Service Limit (1st): 0.18 mm (0.0071 in)  
(2nd): 0.15 mm (0.0059 in)

**DATA** Piston ring groove width:  
Standard (1st): 1.21 – 1.23 mm (0.0476 – 0.0484 in)  
(2nd): 1.01 – 1.03 mm (0.0398 – 0.0406 in)  
(Oil): 2.01 – 2.03 mm (0.0791 – 0.0799 in)

**DATA** Piston ring thickness:  
Standard (1st): 1.175 – 1.190 mm (0.04626 – 0.04685 in)  
(2nd): 0.970 – 0.990 mm (0.03819 – 0.03898 in)

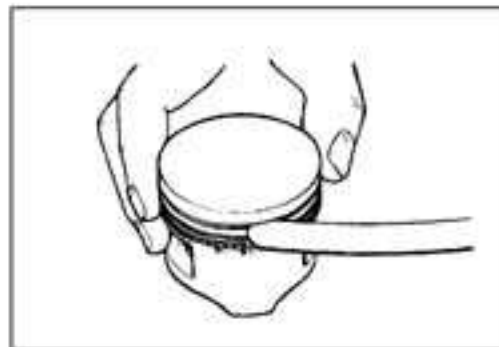
**PISTON RING FREE END GAP AND PISTON RING END GAP**

- Measure the piston ring free end gap using vernier calipers.
- Next, fit the piston ring squarely into the cylinder and measure the piston ring end gap using the thickness gauge.
- If any of the measurements exceed the service limit, replace the piston ring with a new one.

**TOOL** 09900-20102: Vernier calipers

**DATA** Piston ring free end gap:  
Service Limit (1st) : 7.6 mm (0.30 in)  
(2nd): 8.8 mm (0.35 in)

**TOOL** 09900-20803: Thickness gauge

**DATA** Piston ring end gap:  
Service Limit (1st) : 0.50 mm (0.020 in)  
(2nd): 0.50 mm (0.020 in)

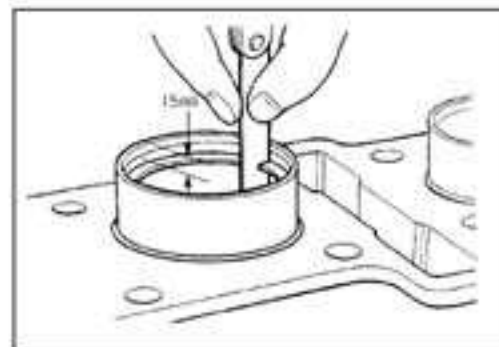

## CLUTCH

### CLUTCH DRIVE PLATES INSPECTION

#### NOTE:

Wipe off engine oil from the clutch drive plates with a clean rag.

- Measure the thickness of drive plates with a vernier calipers.
- If each drive plate thickness is less than the limit, replace it with a new one.

#### DATA Drive plate thickness:

Service Limit (No.1, 2 and 3): 2.42 mm (0.095 in)

#### TOOL 09900-20102: Vernier calipers

- Measure the claw width of drive plates with a vernier calipers.
- Replace the drive plates found to have worn down to the limit.

#### DATA Drive plate claw width:

Service Limit: (No.1, 2 and 3) 13.05 mm (0.5138 in)

#### TOOL 09900-20102: Vernier calipers

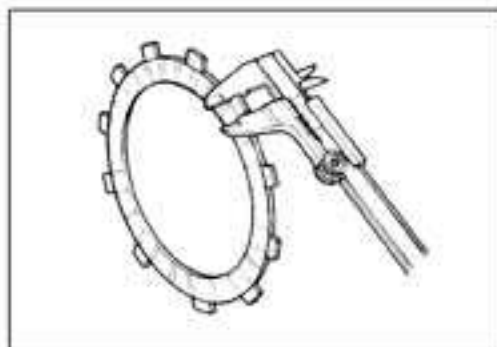
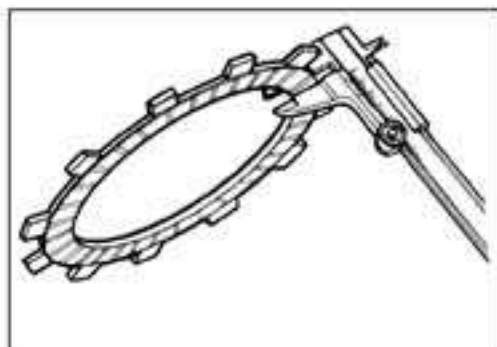

### CLUTCH DRIVEN PLATES INSPECTION

#### NOTE:

Wipe off engine oil from the clutch driven plates with a clean rag.

- Measure each driven plate for distortion with a thickness gauge and surface plate.
- Replace driven plates which exceed the limit.

#### DATA Driven plate distortion (No.1, 2 and 3):

Service Limit: 0.10 mm (0.004 in)

#### TOOL 09900-20803: Thickness gauge

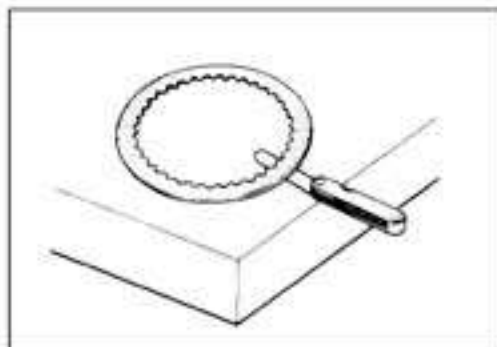

### CLUTCH SPRING INSPECTION

- Measure the free length of each coil spring with a vernier calipers, and compare the length with the specified limit.
- Replace all the springs if any spring is not within the limit.

#### DATA Clutch spring free length:

Service Limit: 73.9 mm (2.909 in)

#### TOOL 09900-20102: Vernier calipers

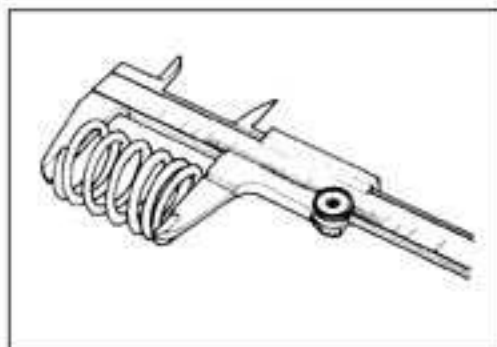

### CLUTCH BEARING INSPECTION

- Inspect the clutch release bearing for any abnormality, particularly cracks, to decide whether it can be reused or should be replaced.
- Smooth engagement and disengagement of the clutch depends on the condition of this bearing.





## GEARSHIFT SYSTEM

### GEARSHIFT SHAFT/GEARSHIFT ARM DISASSEMBLY

- Remove the following parts from the gearshift shaft/gearshift arm.

- |                                 |                       |
|---------------------------------|-----------------------|
| ① Washer                        | ⑤ Plate return spring |
| ② Circlip                       | ⑥ Washer              |
| ③ Gearshift shaft return spring | ⑦ Circlip             |
| ④ Gearshift cam drive plate     |                       |

 09900-06107: Snap ring pliers

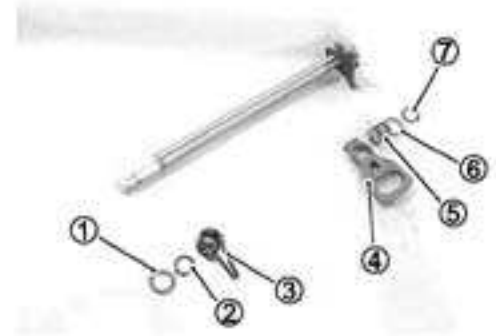

### GEARSHIFT SHAFT/GEARSHIFT ARM INSPECTION

- Inspect the gearshift shaft/gearshift arm for wear or bend.
- Inspect the return springs for damage or fatigue.
- Replace the arm or spring if there is anything unusual.

### GEARSHIFT SHAFT/GEARSHIFT ARM REASSEMBLY

- Install the following parts to the gearshift shaft/gearshift arm as shown in the illustration.

 09900-06107: Snap ring pliers

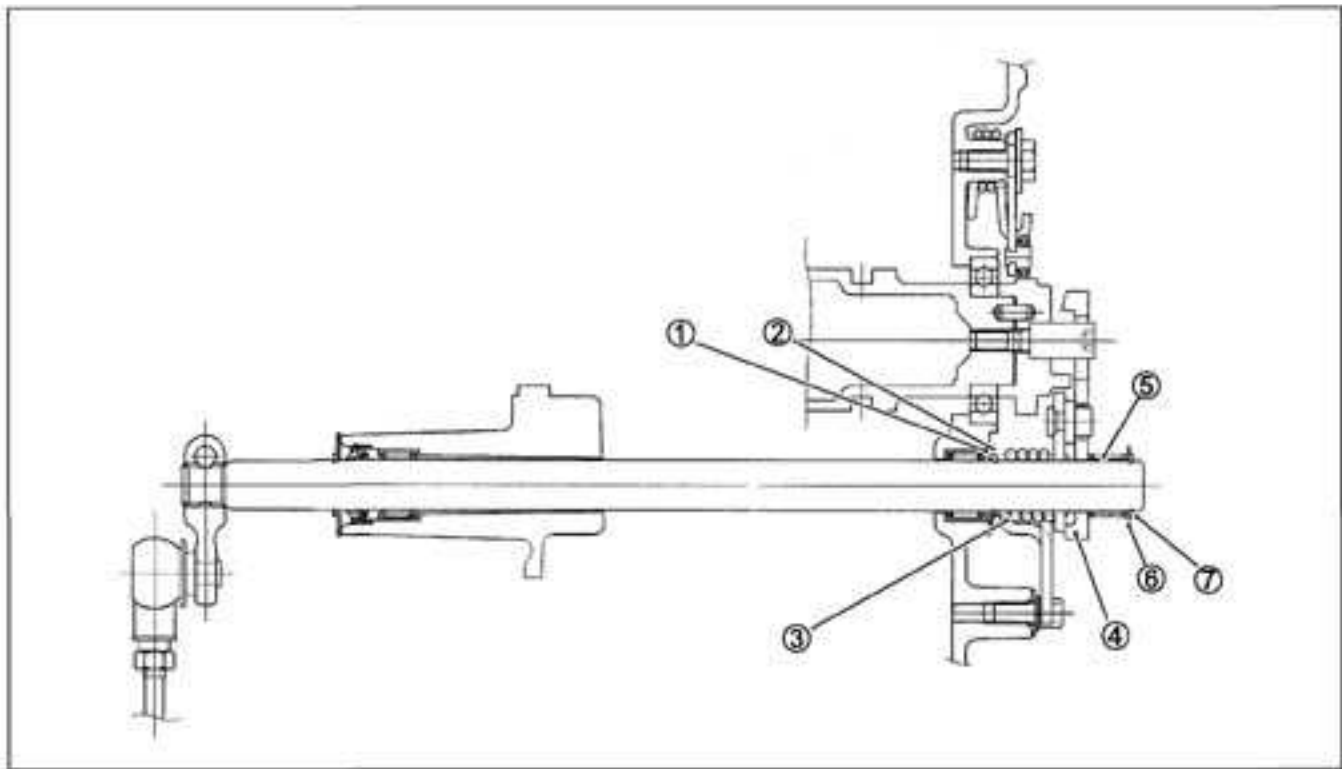

#### NOTE:

When installing the gearshift shaft return spring, position the stopper of the gearshift arm between the shaft return spring ends.





## BACK TORQUE LIMITER

- Inspect the back torque limiter for wear or damage. If any defects are found, replace it with a new one.
- Apply a small quantity of thread lock to the clutch spring guide bolt and tighten it.

 99000-32050: THREAD LOCK "1342"

 Clutch spring guide bolt: 23 N·m (2.3 kgf·m, 17 lb-ft)



## GENERATOR

INSPECTION:  7-8

### REASSEMBLY

- When installing the generator stator set bolts, tighten them to the specified torque.

 Generator stator set bolt: 10 N·m (1.0 kgf·m, 7.4 lb-ft)

### NOTE:

Be sure to install the grommet to the generator cover.

## STARTER CLUTCH

### INSPECTION

- Inspect the starter clutch for abnormal wear or damage.
- Turn the starter driven gear and inspect the starter clutch for smooth movement.
- Inspect that the gear turns one direction only.
- If they are found to be damaged, replace them with new ones.

### INSTALLATION

- Face the shoulder  of starter clutch to generator rotor, install them.

 Starter clutch bolt: 25 N·m (2.5 kgf·m, 18 lb-ft)



## OIL PUMP

### INSPECTION

- Rotate the oil pump by hand and check that it moves smoothly.
- If it does not move smoothly, replace the oil pump assembly.

### CAUTION

- Do not attempt to disassemble the oil pump assembly.
- The oil pump is available only as an assembly.



## OIL PRESSURE REGULATOR

- Inspect the operation of the oil pressure regulator by pushing on the piston with a proper bar.
- If the piston does not operate, replace the oil pressure regulator with a new one.



## OIL STRAINER

- Inspect the oil strainer body for damage.
- Clean the oil strainer if necessary.



## CRANK BALANCER

### DISASSEMBLY

- Disassemble the crank balancer assembly.

- |                        |           |
|------------------------|-----------|
| ① Crank balancer       | ④ Washer  |
| ② Balancer gear damper | ⑤ Bearing |
| ③ Balancer gear        | ⑥ Spacer  |

### INSPECTION

- Inspect the balancer shaft for wear or damage.
- Inspect the bearing, the damper and the gear for wear or damage.
- If there is anything unusual, replace them with new ones.

### REASSEMBLY

- Apply engine oil to each parts.
- Assemble the crank balancer as follow;
- Install the convex parts on crank balancer between dampers.

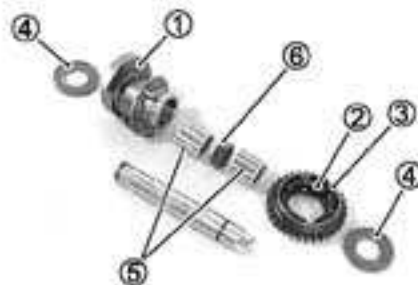

- Align the engraved line (A) on the crank balancer with the punched mark (B) on the balancer gear.

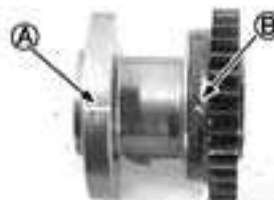

## TRANSMISSION

- Disassemble the countershaft and driveshaft.  
Pay attention to the following points:

 **09900-06104: Snap ring pliers**

- Slide the 6th (TOP) drive gear circlip (B) from its groove towards the 3rd/4th drive gears.
- Slide the 2nd drive gear towards the 6th (TOP) drive gear, then remove the 2nd drive gear circlip (A).

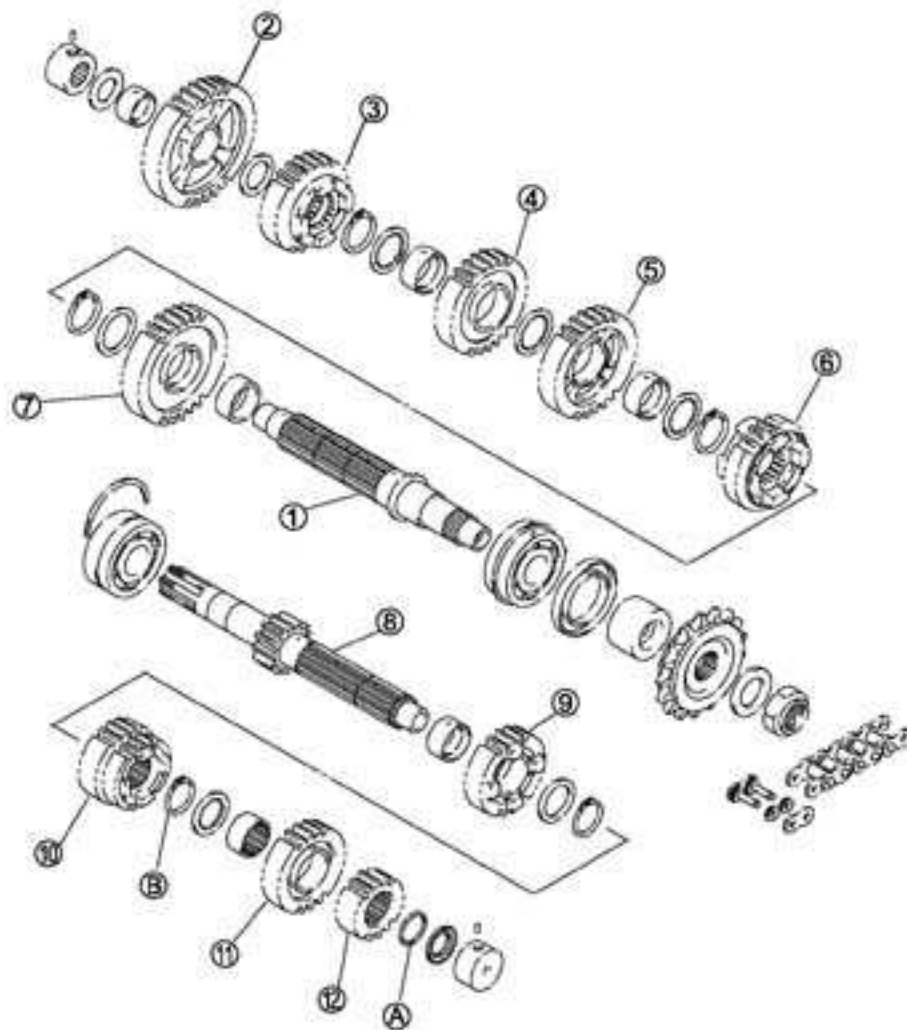
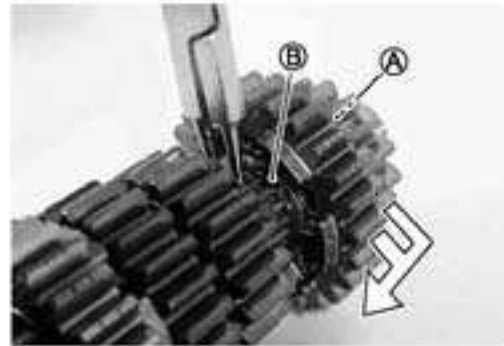

- ① Driveshaft
- ② 1st driven gear
- ③ 5th driven gear
- ④ 4th driven gear
- ⑤ 3rd driven gear
- ⑥ 6th driven gear
- ⑦ 2nd driven gear
- ⑧ Countershaft / 1st drive gear
- ⑨ 5th drive gear
- ⑩ 3rd/4th drive gear
- ⑪ 6th drive gear
- ⑫ 2nd drive gear

**GEAR**

- Inspect the teeth of gear for wear, scratch or damage.
- Inspect the dock of gear for wear or damage.
- If there are anything unusual, replace them with new ones.

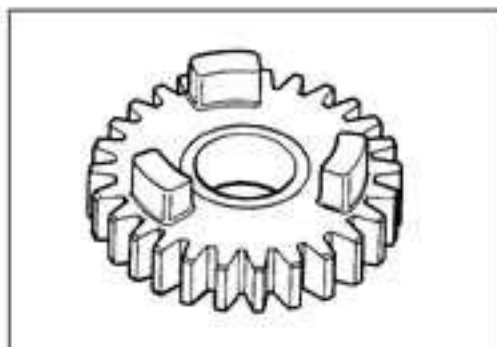
**GEARSHIFT FORK TO GROOVE CLEARANCE**

- Using a thickness gauge, check the gearshift fork clearance in the groove of its gear.
- The clearance for each gearshift fork plays an important role in the smoothness and positiveness of the shifting action.

**DATA** Shift fork to groove clearance:  
 Standard: 0.1 – 0.3 mm (0.004 – 0.012 in)  
 Service Limit: 0.50 mm (0.020 in)

 09900-20803: Thickness gauge

- If the clearance checked is noted to exceed the limit specified, replace the fork or its gear, or both.

**GEARSHIFT FORK GROOVE WIDTH**

- Measure the gearshift fork groove width using the vernier calipers.

**DATA** Shift fork groove width:  
 Standard: 5.0 – 5.1 mm (0.197 – 0.201 in)

 09900-20102: Vernier calipers

**GEARSHIFT FORK THICKNESS**

- Measure the gearshift fork thickness using the vernier calipers.

**DATA** Shift fork thickness:  
 Standard: 4.8 – 4.9 mm (0.189 – 0.193 in)

 09900-20102: Vernier calipers

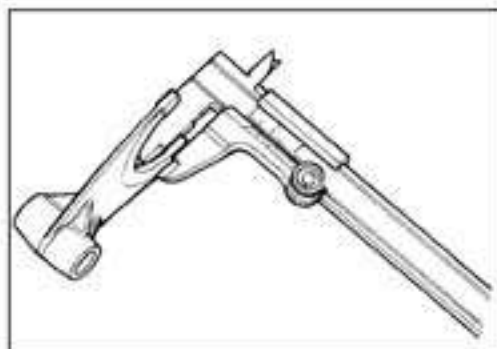
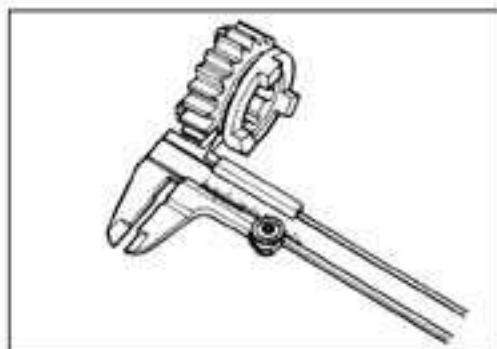
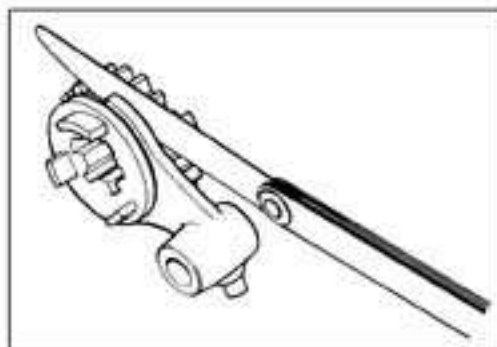
**REASSEMBLY**

Assemble the countershaft and driveshaft in the reverse order of disassembly. Pay attention to the following points:

**NOTE:**

- \* Rotate the bearings by hand to inspect for smooth rotation. Replace the bearings if there is anything unusual.
- \* Before installing the gears, apply engine oil to the driveshaft and countershaft.
- \* Before installing the oil seal, apply grease to oil seal.

 99000-25010: SUZUKI SUPER GREASE "A"

**CAUTION**

- Never reuse a circlip. After a circlip has been removed from a shaft, it should be discarded and a new circlip must be installed.
- When installing a new circlip, do not expand the end gap larger than required to slip the circlip over the shaft.
- After installing a circlip, make sure that it is completely seated in its groove and securely fitted.

**NOTE:**

When reassembling the transmission, attention must be given to the locations and positions of washers and circlips. The cross sectional view shows the correct position of the gears, bushings, washers and circlips.

- When installing a new circlip, pay attention to the direction of the circlip. Fit it to the side where the thrust is as shown in the illustration.

**CAUTION**

When installing the gear bushing onto the shaft, align the shaft oil hole with the bushing oil hole.

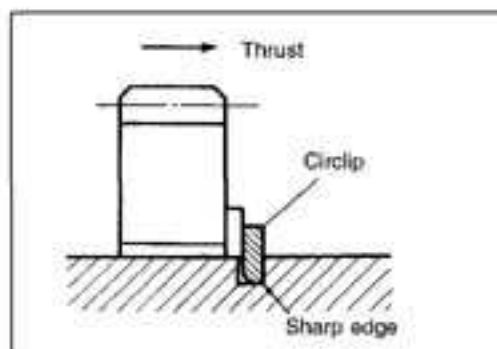
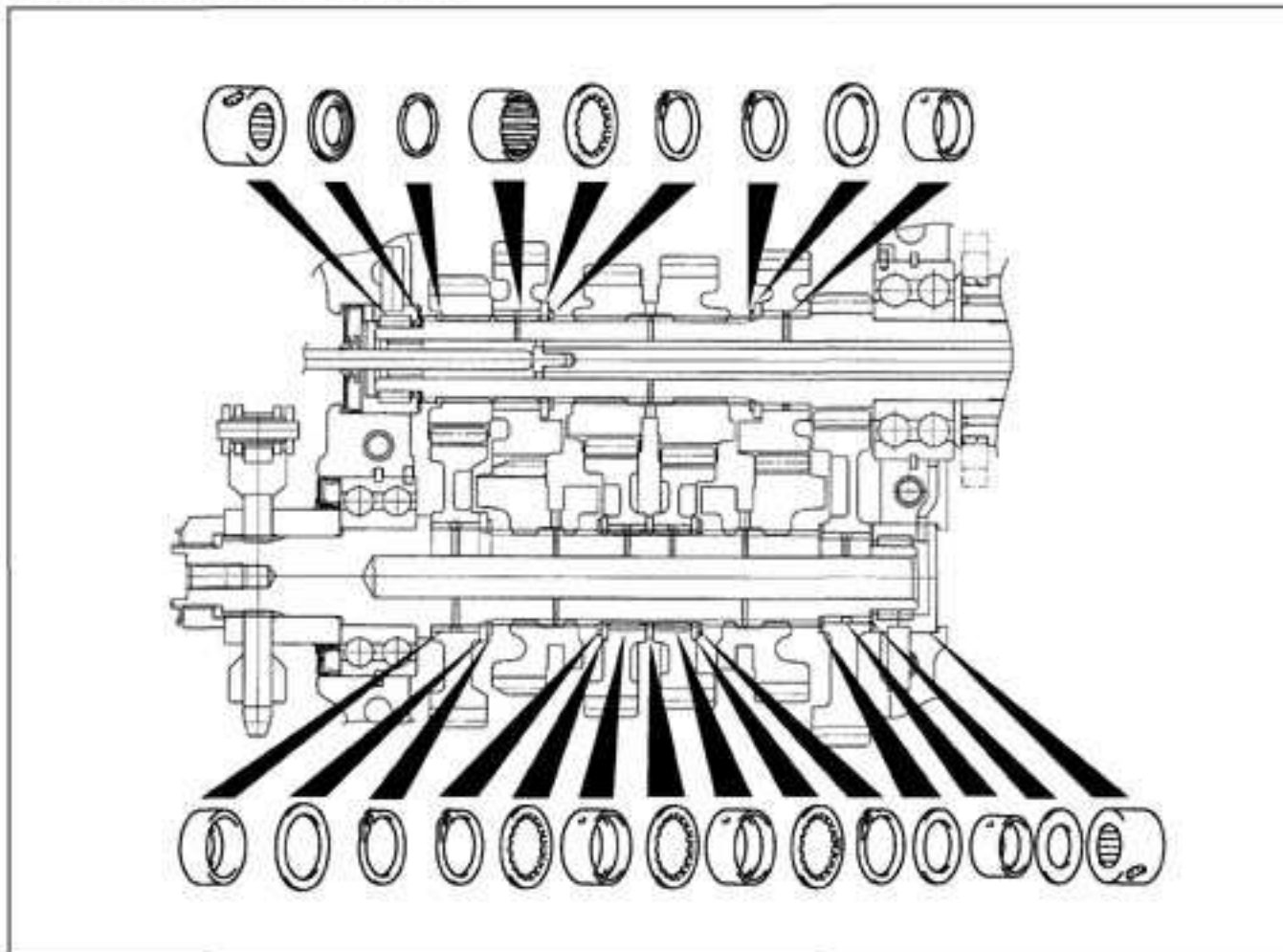
**TRANSMISSION PARTS LOCATION**

## CRANKSHAFT AND CONROD

### CRANKSHAFT RUNOUT

- Support the crankshaft with "V" blocks as shown, with the two end journals resting on the blocks.
- Set up the dial gauge, as shown.
- Rotate the crankshaft slowly to read the runout.
- Replace the crankshaft if the runout is greater than the limit.

- FOX** 09900-20606: Dial gauge (1/100 mm, 10 mm)  
 09900-20701: Magnetic stand  
 09900-21304: V-block (100 mm)

- DATA** Crankshaft runout:  
 Service Limit: 0.05 mm (0.002 in)

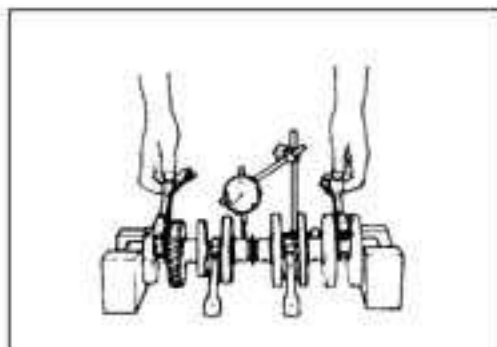

### CONROD SMALL END I.D.

- Using a small bore gauge, measure the inside diameter of the conrod small end.

- FOX** 09900-20602: Dial gauge (1/1000 mm, 1 mm)  
 09900-22401: Small bore gauge (10 – 18 mm)

- DATA** Conrod small end I.D.:  
 Service Limit: 18.040 mm (0.7102 in)

- If the inside diameter of the conrod small end exceeds the limit, replace the conrod.

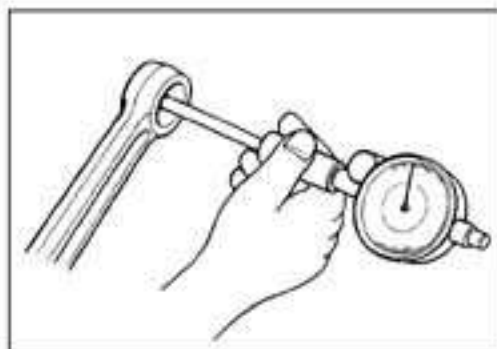

### CONROD BIG END SIDE CLEARANCE

- Inspect the conrod side clearance by using a thickness gauge.
- If the clearance exceeds the limit, remove the conrod and inspect the conrod big end width and the crank pin width.
- If the width exceed the limit, replace conrod or crankshaft.

- DATA** Conrod big end side clearance:  
 Service Limit: 0.30 mm (0.012 in)

- FOX** 09900-20803: Thickness gauge

- DATA** Conrod big end width:  
 Standard: 20.95 – 21.00 mm (0.8248 – 0.8268 in)

- FOX** 09900-20205: Micrometer (0 – 25 mm)

- DATA** Crank pin width:  
 Standard: 21.10 – 21.15 mm (0.8307 – 0.8327 in)

- FOX** 09900-20605: Dial calipers (1/100 mm, 10 – 34 mm)

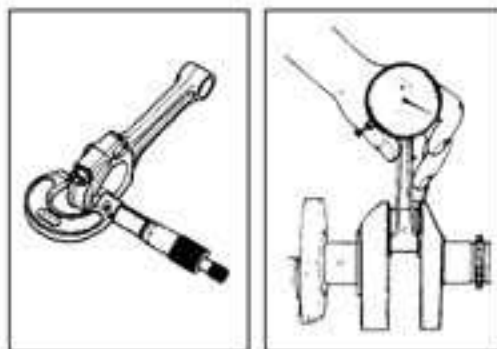
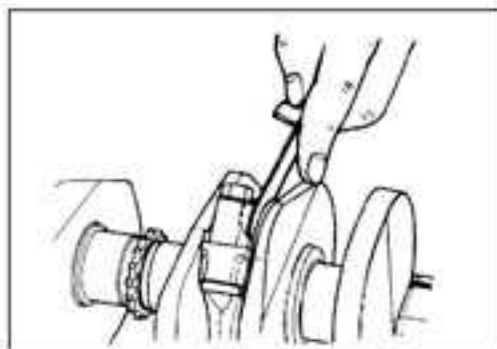



**CONROD-CRANK PIN BEARING INSPECTION**

- Inspect the bearing surfaces for any sign of fusion, pitting, burn, or flaws. If any, replace them with a specified set of bearings.
- If the oil clearance exceeds the service limit, select the specified bearings from the bearing selection table.

**CONROD-CRANK PIN BEARING SELECTION**

- Place the plastigauge axially along the crank pin, avoiding the oil hole, as shown.

 09900-22301: Plastigauge

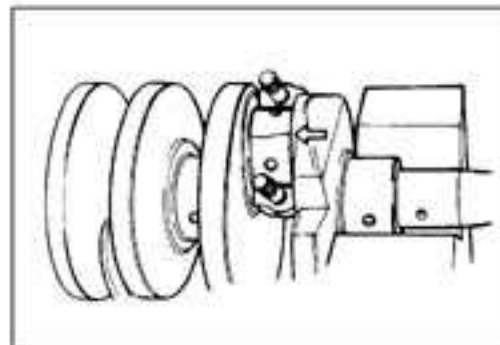

- Tighten the conrod cap bolts to the specified torque, in two stages. ( 3-48)

**CAUTION**

- Apply engine oil to the bearing cap bolt.
- Never rotate the crankshaft or conrod when a piece of plastigauge is installed.
- Remove the bearing caps and measure the width of the compressed plastigauge using the envelope scale. This measurement should be taken at the widest part of the compressed plastigauge.

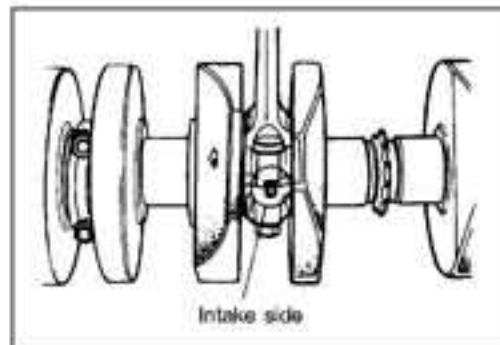

**DATA** Conrod big end oil clearance:  
 Standard: 0.032 – 0.056 mm (0.0013 – 0.0022 in)  
 Service Limit: 0.080 mm (0.0031 in)

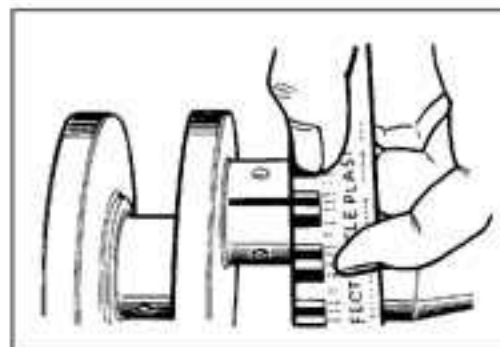

- Check the corresponding conrod I.D. code number (A) stamped on the conrod.
- Check the corresponding crank pin O.D. code number (B) stamped on the crankshaft.

**DATA** Bearing selection table

	Code	Crank pin O.D. (B)		
		1	2	3
Conrod	1	Green	Black	Brown
I.D. (A)	2	Black	Brown	Yellow

**DATA** Conrod I.D.

Code	I.D. specification
1	41.000 – 41.008 mm (1.6142 – 1.6145 in)
2	41.008 – 41.016 mm (1.6145 – 1.6148 in)

**DATA** Crank pin O.D.

Code	O.D. specification
1	37.992 – 38.000 mm (1.4957 – 1.4961 in)
2	37.984 – 37.992 mm (1.4954 – 1.4957 in)
3	37.976 – 37.984 mm (1.4951 – 1.4954 in)

**TOOL** 09900-20202: Micrometer (25 – 50 mm)**DATA** Bearing thickness

Color (Part No.)	Thickness
Green (12164-46E01-0A0)	1.480 – 1.484 mm (0.0583 – 0.0584 in)
Black (12164-46E01-0B0)	1.484 – 1.488 mm (0.0584 – 0.0586 in)
Brown (12164-46E01-0C0)	1.488 – 1.492 mm (0.0586 – 0.0587 in)
Yellow (12164-46E01-0D0)	1.492 – 1.496 mm (0.0587 – 0.0589 in)

**CAUTION**

The bearings must be replaced as a set.

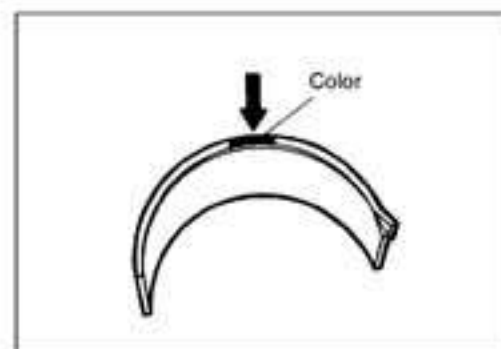
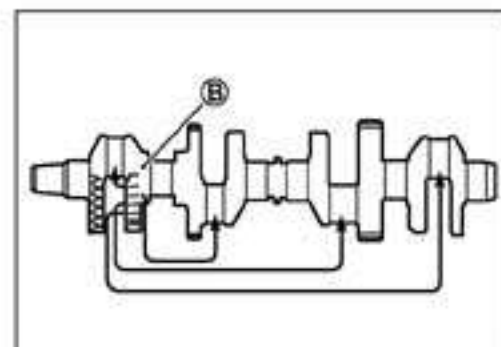
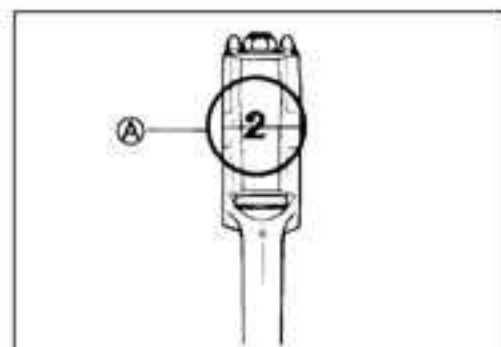

**INSTALLATION**

- When fitting the bearing to the bearing cap and conrod, be sure to fix the stopper part (A) first and press in the other end.

**CAUTION**

**Be sure to clean the conrod big end.**

- Apply molybdenum oil solution to the crank pin and bearing surface.

 **Molybdenum oil**

- When fitting the conrods on the crankshaft, make sure that I.D.code (1) on each conrod faces toward intake valve side.

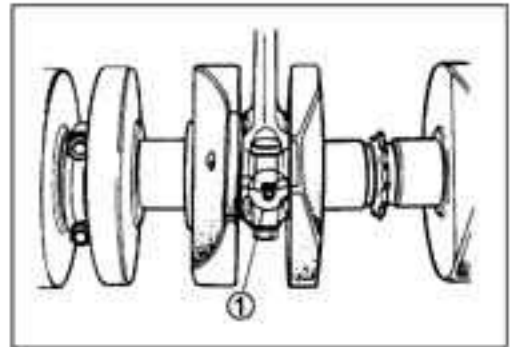

- Tighten the conrod cap bolt as following two steps.

 **Conrod cap bolt:** Initial: 21 N·m (2.1 kgf·m, 15 lb-ft)  
Final: 90°

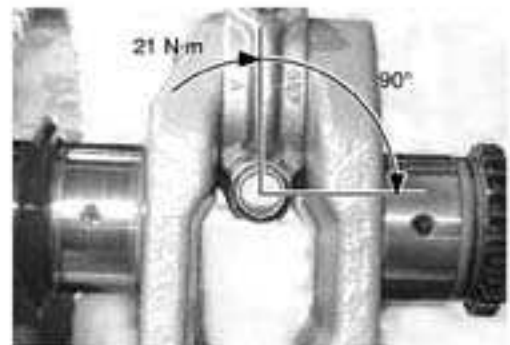

## CRANKSHAFT JOURNAL BEARING

### INSPECTION

- Inspect each bearing of upper and lower crankcases for any damage.

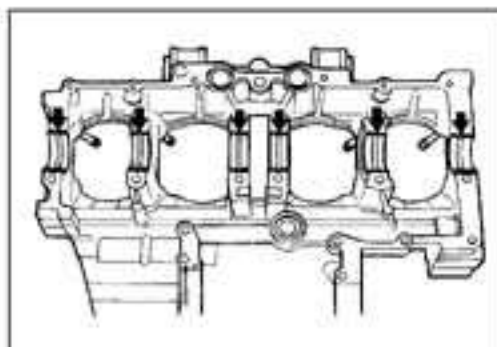

### SELECTION

- Place the plastigauge axially along the crankshaft journal, avoiding the oil hole, as shown.

 09900-22301: Plastigauge

### CAUTION

Never rotate the crankshaft when a piece of plastigauge is installed.

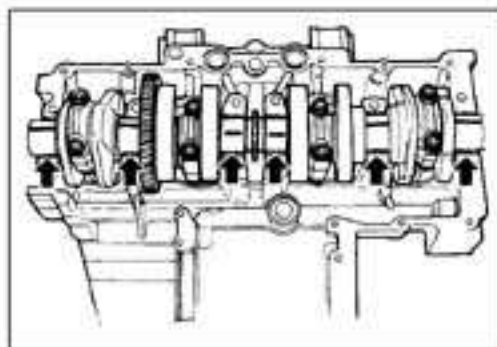

- Mate the lower crankcase with the upper crankcase, and tighten the crank journal bolts (M9) as following two steps in the indicated order.

### Crank journal bolt (9 mm)

Initial : 18 N·m (1.8 kgf·m, 13 lb-ft)

Initial : 32 N·m (3.2 kgf·m, 24 lb-ft)

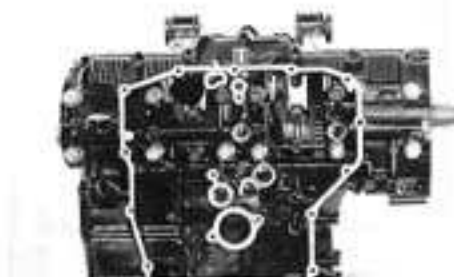

- Remove the lower crankcase and measure the width of the compressed plastigauge using the envelope scale. This measurement should be taken at the widest part of the compressed plastigauge.

### **DATA** Crankshaft journal bearing oil clearance:

Standard: 0.016 – 0.040 mm (0.00063 – 0.00157 in)

Service Limit: 0.080 mm (0.0031 in)

- If the oil clearance exceeds the service limit, select the specified bearings from the bearing selection table.

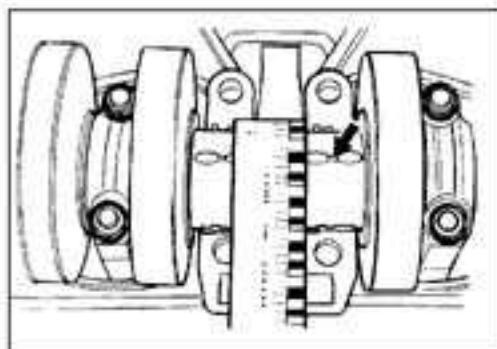

- Check the corresponding crankcase journal I.D. code number (A) stamped on the upper crankcase.
- Check the corresponding crankshaft journal O.D. code number (B) stamped on the crankshaft.

**DATA** Bearing selection table

	Code	Crankshaft journal O.D. (B)		
		A	B	C
<b>Crankcase</b>	A	Green	Black	Brown
<b>I.D. (A)</b>	B	Black	Brown	Yellow

**DATA** Crankcase I.D. specification

Code	I.D. specification
A	43.000 – 43.008 mm (1.6929 – 1.6932 in)
B	43.008 – 43.016 mm (1.6932 – 1.6935 in)

**DATA** Crankshaft journal O.D. specification

Code	O.D. specification
A	39.992 – 40.000 mm (1.5745 – 1.5748 in)
B	39.984 – 39.992 mm (1.5742 – 1.5745 in)
C	39.976 – 39.984 mm (1.5739 – 1.5742 in)

**tools** 09900-20202: Micrometer (25 – 50 mm)**DATA** Bearing thickness specification

Color (Part No.)	Thickness
Green (12229-24F00-0A0)	1.488 – 1.492 mm (0.0586 – 0.0587 in)
Black (12229-24F00-0B0)	1.492 – 1.496 mm (0.0587 – 0.0589 in)
Brown (12229-24F00-0C0)	1.496 – 1.500 mm (0.0589 – 0.0591 in)
Yellow (12229-24F00-0D0)	1.500 – 1.504 mm (0.0591 – 0.0592 in)

**NOTE:**

Upper and lower crankshaft journal bearings are the same.

**INSTALLATION**

- When fitting the crankshaft journal bearings to the upper and lower crankcases, be sure to fix the stopper part (A) first and press the other end.

**CAUTION**

Do not touch the bearing surfaces with your hands.  
Grasp by the edge of the bearing shell.

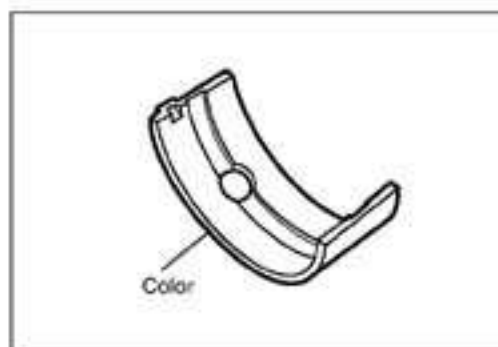
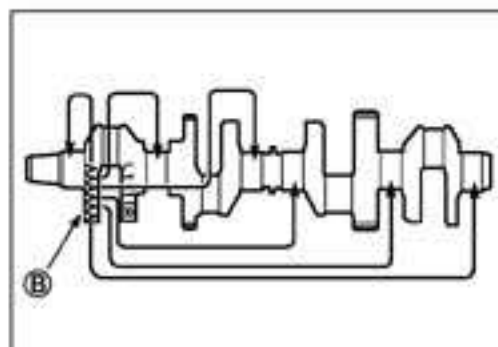
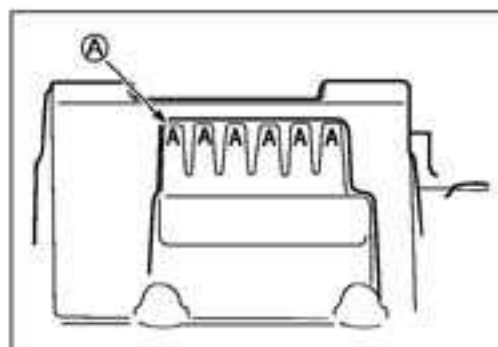

## CRANKSHAFT THRUST BEARING

- With the crankshaft, right-side thrust bearing and left-side thrust bearing inserted in the upper crankcase, measure the thrust clearance on the left side by using the thickness gauge.

- ①: Right-side thrust bearing
- ②: Left-side thrust bearing

### NOTE:

Pull the crankshaft to the left-side, so that there is no clearance on the right-side thrust bearing.

 09900-20803: Thickness gauge

### DATA Thrust clearance:

Standard: 0.070 – 0.110 mm (0.0028 – 0.0043 in)

- If the thrust clearance exceeds the standard range, adjust the thrust clearance by the following procedures.

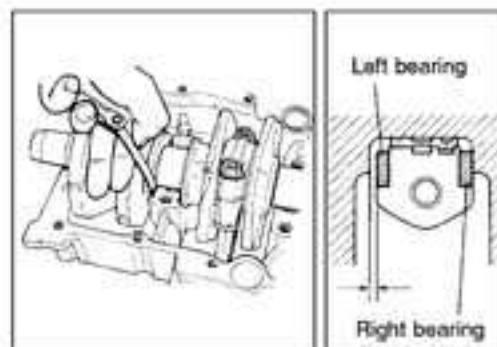
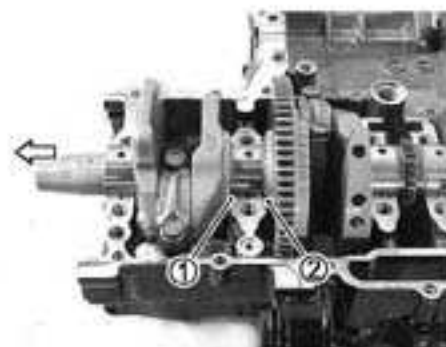

## CRANKSHAFT THRUST CLEARANCE ADJUSTMENT

- Remove the right-side thrust bearing and measure its thickness with a micrometer.
- If the thickness of the right-side thrust bearing is below standard, replace it with a new one and once again perform the thrust clearance measurement listed above, checking to make sure it is within standard.

 09900-20205: Micrometer

### DATA Right-side thrust bearing thickness:

Standard: 2.425 – 2.450 mm (0.0955 – 0.0965 in)

- If the right-side thrust bearing is within the standard range, reinsert the right-side thrust bearing and remove the left-side thrust bearing.
- As shown in the illustration, measure the clearance by using a thickness gauge before inserting of the left-side thrust bearing.
- Select a left-side thrust bearing from the selection table. ( 3-52)

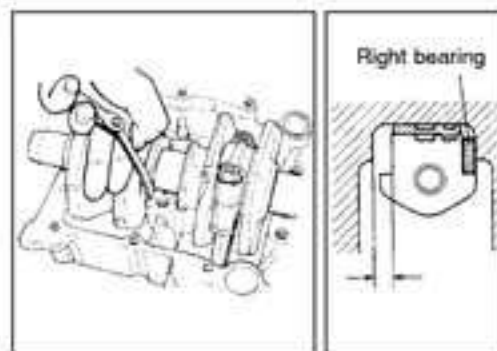

**DATA** Thrust bearing selection table

Clearance before inserting left-side thrust bearing	Color (Part No.)	Thrust bearing thickness	Thrust clearance
2.560 – 2.585 mm (0.1008 – 0.1018 in)	White (12228-24F00-0F0)	2.475 – 2.500 mm (0.0974 – 0.0984 in)	0.060 – 0.110 mm (0.0024 – 0.0043 in)
2.535 – 2.560 mm (0.0998 – 0.1008 in)	Yellow (12228-24F00-0E0)	2.450 – 2.475 mm (0.0965 – 0.0974 in)	0.060 – 0.110 mm (0.0024 – 0.0043 in)
2.510 – 2.535 mm (0.0982 – 0.0998 in)	Green (12228-24F00-0D0)	2.425 – 2.450 mm (0.0954 – 0.0965 in)	0.060 – 0.110 mm (0.0024 – 0.0043 in)
2.485 – 2.510 mm (0.0978 – 0.0982 in)	Blue (12228-24F00-0C0)	2.400 – 2.425 mm (0.0944 – 0.0954 in)	0.060 – 0.110 mm (0.0024 – 0.0043 in)
2.460 – 2.485 mm (0.0969 – 0.0978 in)	Black (12228-24F00-0B0)	2.375 – 2.400 mm (0.0935 – 0.0944 in)	0.060 – 0.110 mm (0.0024 – 0.0043 in)
2.430 – 2.460 mm (0.0957 – 0.0969 in)	Red (12228-24F00-0A0)	2.350 – 2.375 mm (0.0925 – 0.0935 in)	0.055 – 0.110 mm (0.0022 – 0.0043 in)

- After selecting a left-side thrust bearing, insert it and again perform the thrust clearance measurement to make sure it falls within the standard range.

**NOTE:**

*Right-side thrust bearing has the same specification as the GREEN of left-side thrust bearing.*

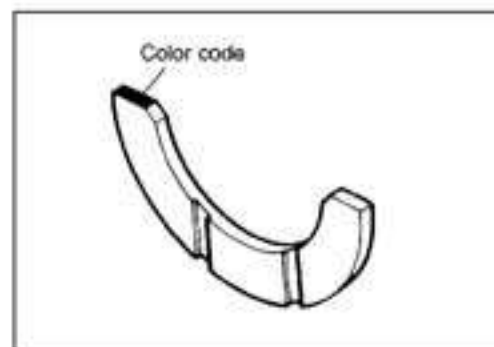



## CRANKCASE/OIL PAN

### OIL CHECK VALVE

- Install the oil check valve.

 Oil check valve: 35 N·m (3.5 kgf·m, 26 lb-ft)



### LOWER CRANKCASE

- Inspect the gearshift shaft bearings (① and ②) and the gearshift cam bearing (③) for abnormal noise and smooth rotation while they are in the crankcase.
- Replace a bearing if there is anything unusual.



### Bearing replacement

- Remove the oil seal.



- Remove the gearshift shaft bearing using the special tool.

 09921-20210: Bearing remover  
09930-30102: Sliding shaft

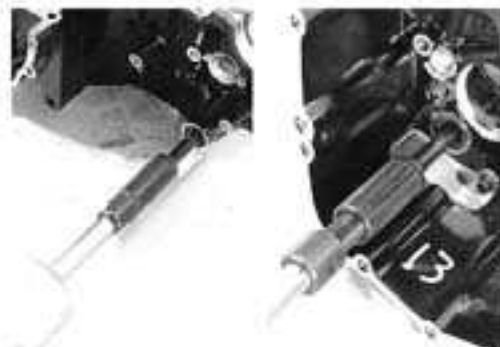

- Install the bearings using the special tool.

 09913-70210: Bearing installer set (20mm)

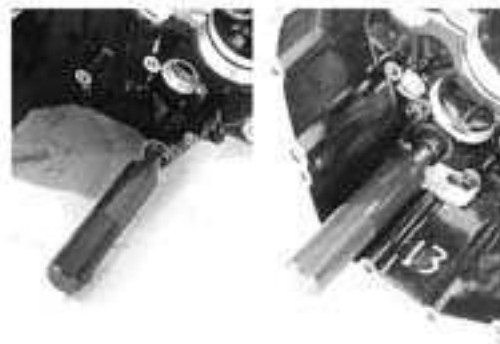

- Remove the gearshift cam bearing using the special tools.

 09923-74510: Bearing remover

09930-30102: Sliding shaft

- Install the bearing using the special tool.

 09913-70210: Bearing installer set (30 mm)

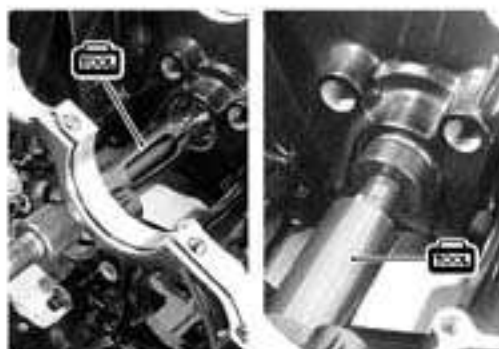

## OIL JET

### Removal

- Remove the piston cooling oil jets ① from the upper crankcase.

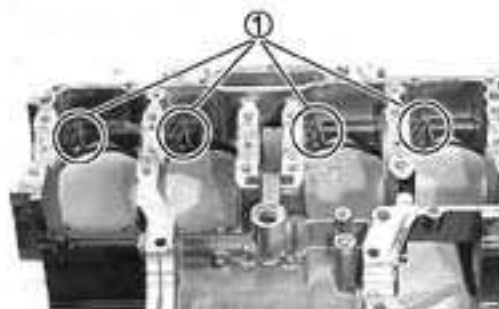

- Remove the oil jets ② (for transmission) from the lower crankcase.



### Inspection

- Check the oil jets for clogging.
- If they are clogged, clean their oil passage with a proper wire and compressed air.

① Piston cooling oil jet

② Oil jet (#12) (For transmission)

### Installation

- Fit the new O-rings to each piston cooling oil jet as shown and apply engine oil to them.

### CAUTION

**Use the new O-rings to prevent oil pressure down.**

- With the thread lock applied to the bolts, install each piston cooling oil jet with the bolts.

 99000-32050: THREAD LOCK "1342"

 Piston cooling oil jet bolt: 10 N·m (1.0 kgf·m, 7.4 lb-ft)



**OIL GALLERY PLUG**

- Install each plug.

- ① Main gallery plug: 35 N·m (3.5 kgf·m, 26 lb-ft)
- ② Main gallery plug: 21 N·m (2.1 kgf·m, 15 lb-ft)
- ③ Sub gallery plug: 35 N·m (3.5 kgf·m, 26 lb-ft)
- ④ Sub gallery plug: 10 N·m (1.0 kgf·m, 7.4 lb-ft)

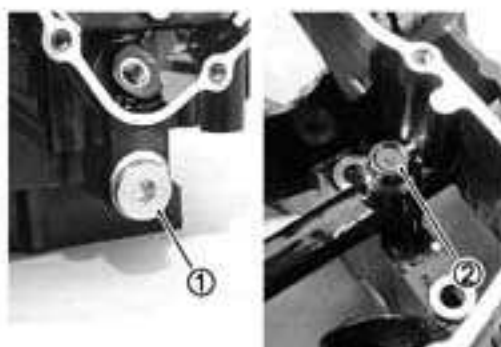

## ENGINE REASSEMBLY

- Reassemble the engine in the reverse order of disassembly.
- The following steps require special attention or precautionary measures should be taken.

### NOTE:

Apply engine oil to each running and sliding part before reassembling.

### OIL PUMP

- Install the dowel pins.
- Apply grease to the O-ring, install the oil pump assembly.

 99000-25010: SUZUKI SUPER GREASE "A"



- Apply a small quantity of thread lock to the bolts and tighten them.

 99000-32050: THREAD LOCK "1342"

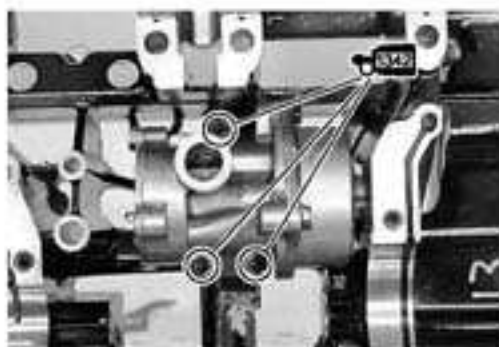

### GEARSHIFT CAM/GEARSHIFT FORK

- Install the gearshift cam with the bearing.
- Install the gearshift forks and their shafts as shown.

- ① Gearshift fork No.1 (For 6th driven gear)
- ② Gearshift fork No.1 (For 5th driven gear)
- ③ Gearshift fork No.3 (For 3rd/4th drive gear)

### NOTE:

The gearshift forks No.1 (① and ②) are the same.

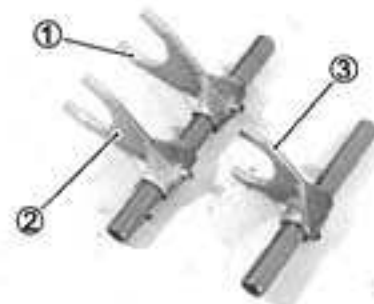

- Apply a small quantity of **THREAD LOCK** to the bearing retainer screws and the shift fork shaft retainer screw and tighten them.

 **99000-32050: THREAD LOCK "1342"**

- Tighten the gearshift shaft spring stopper.

 **Gearshift shaft spring stopper:**

**10 N·m (1.0 kgf·m, 7.4 lb-ft)**



## CRANKSHAFT

- Install the cam chain tensioner.
- Install the cam chain tensioner cushion so that its arrow is directed to front and rear.



- Apply molybdenum oil solution to each crankshaft journal bearing lightly.

 **MOLYBDENUM OIL SOLUTION**

- Set the crankshaft to the crankcase with the cam chain.

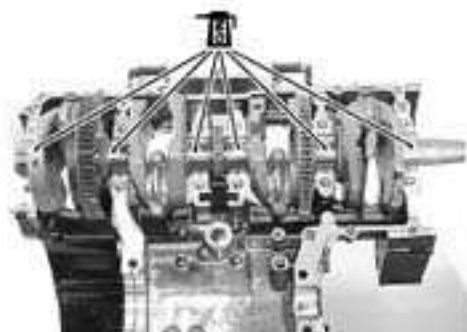

- Apply molybdenum oil solution to the thrust bearings and insert the right and left-thrust bearings with oil groove facing the crank web.

 **MOLYBDENUM OIL SOLUTION**

**NOTE:**

*Right-thrust bearing has green painting.*

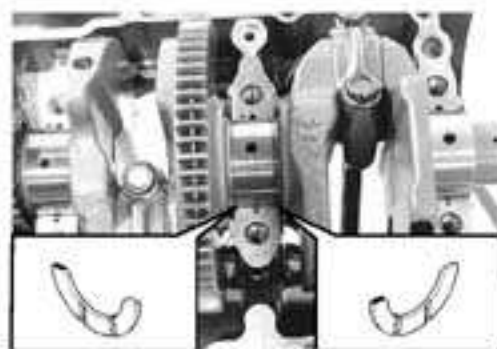

**TRANSMISSION**

- Install the bearing pins ① and the C-ring ② on the upper crankcase.

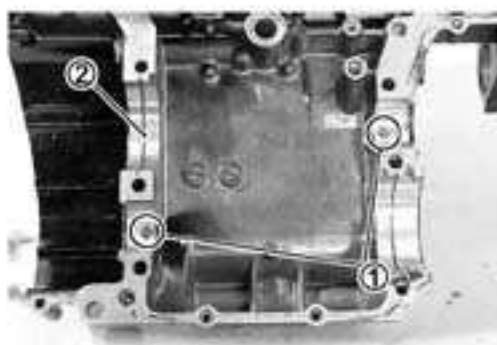

- Install the countershaft assembly on the upper crankcase.

**NOTE:**

*Align the C-ring with the groove on the bearing and the bearing pin with the indent on the bearing.*

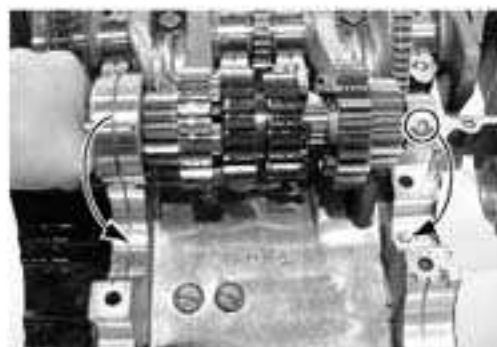

- Install the driveshaft assembly on the upper crankcase.

**NOTE:**

*Align the bearing ring with the groove on the crankcase and the bearing pin with the indent on the bearing.*

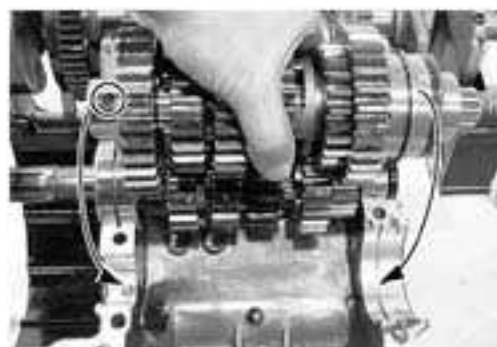

- Install the oil seal ③.
- Install the O-rings ④ and ⑤.
- Install the dowel pins.

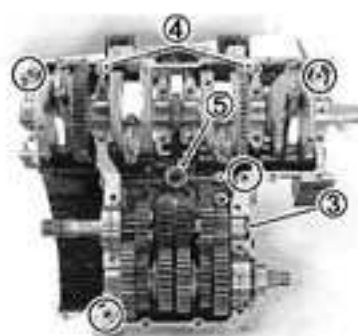

- Turn the bearings to install the bearing dowel pins (A) in the respective positions.

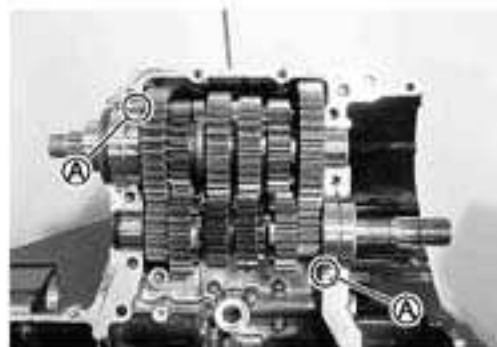

- Apply SUZUKI BOND to the mating surface of the lower crankcase.

 99000-31140: SUZUKI BOND "1207B"

**NOTE:**

Use of SUZUKI BOND is as follows:

- \* Make surfaces free from moisture, oil, dust and other foreign materials.
- \* Spread on surfaces thinly to form an even layer, and assemble the crankcases within few minutes.
- \* Take extreme care not to apply any BOND to the oil hole, oil groove and bearing.
- \* Apply to distorted surfaces as it forms a comparatively thick film.

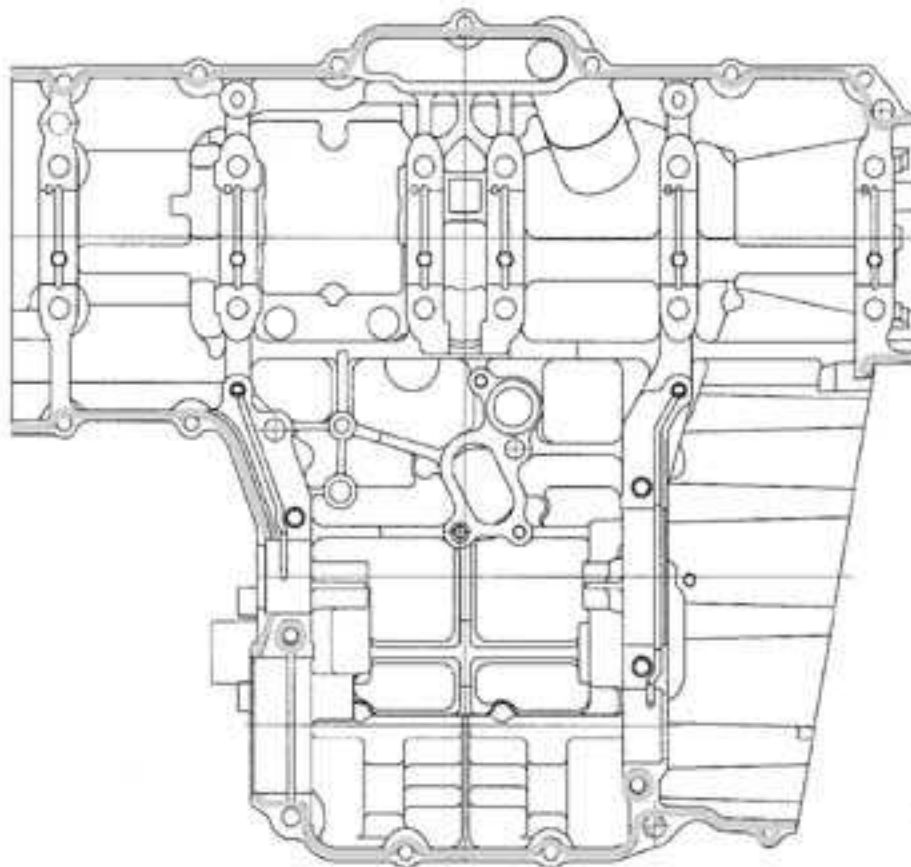
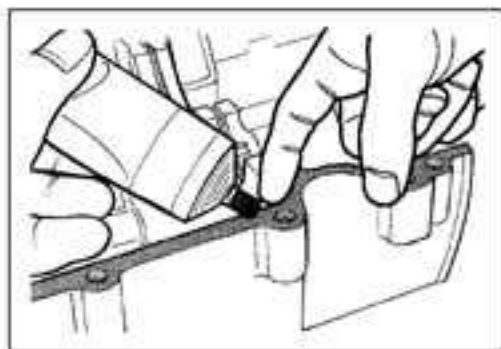





- Match the upper and lower crankcases.
- Tighten the crank journal bolt (9 mm) in ascending order of numbers assigned to these bolts. Tighten each bolt a little at a time to equalize the pressure as following two steps.

**🔧 Crank journal bolt: (M9)**

**Initial: 18 N·m (1.8 kgf·m, 13 lb-ft)**

**Final: 32 N·m (3.2 kgf·m, 24 lb-ft)**

**NOTE:**

Fit the copper washer to the bolt (A).

- Tighten the other crankcase bolts a little at a time to equalize the pressure.

**🔧 Crankcase bolt: (M8): 26 N·m (2.6 kgf·m, 19 lb-ft)**

**Crankcase bolt: (M6): 11 N·m (1.1 kgf·m, 8.1 lb-ft)**

**NOTE:**

Fit the copper washer to the crankcase bolt (A).

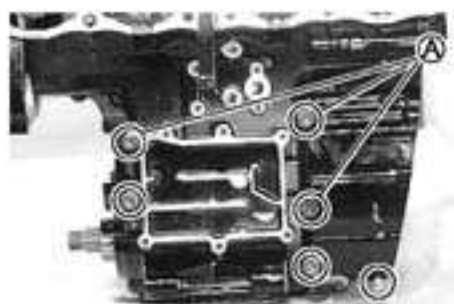

**NOTE:**

After the crankcase bolts have been tightened, check if the crankshaft and transmission rotate smoothly.

**CRANK BALANCER**

- Install the signal generator and the rotor temporarily.
- Rotate the crankshaft so as to align the "T" line on the rotor with the tip of signal generator sensor.

**NOTE:**

Hold the crankshaft so as not to rotate during the crank balancer installing.

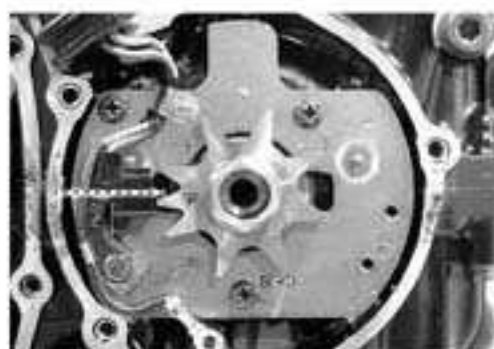

- Align the line (A) and the punched mark (B) on the crank balancer with the index (Δ) on the crankcase.



- Apply engine oil to the balancer shaft and insert it.



- Apply a small quantity of thread lock to the balancer lever bolt and tighten it to the specified torque.

 **99000-32050: THREAD LOCK "1342"**

 **Balancer lever bolt: 10 N·m (1.0 kgf·m, 7.4 lb-ft)**

- Slowly turn the balancer shaft clockwise until it is stop.



- From this position, turn the balancer shaft counterclockwise by 1.5 – 2 graduations and tighten the lock bolt.

 **Balancer lever lock bolt: 10 N·m (1.0 kgf·m, 7.4 lb-ft)**



- Apply a small quantity of thread lock to the bolt and install the balancer cover.

 **99000-32050: THREAD LOCK "1342"**

 **Balancer cover bolt: 10 N·m (1.0 kgf·m, 7.4 lb-ft)**



#### OIL PIPE

- Apply grease to the O-rings and install the main gallery oil pipe.

 **99000-25010: SUZUKI SUPER GREASE "A"**



- Set the stopper of oil return pipe in the convex on crankcase.



### OIL STRAINER

- With grease applied to the O-ring, install the oil strainer.

 99000-25010: SUZUKI SUPER GREASE "A"

 Oil strainer bolt: 10 N·m (1.0 kgf·m, 7.4 lb-ft)

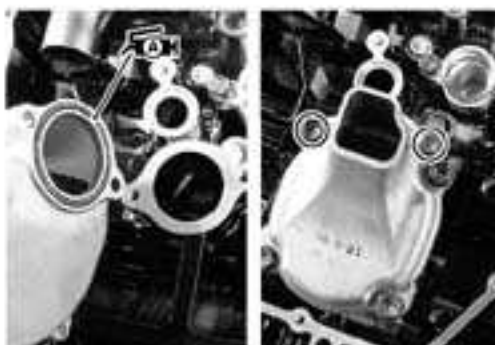

- Apply grease to the O-ring and install it with the shim.

 99000-25010: SUZUKI SUPER GREASE "A"



### OIL PAN

- Install the gasket.

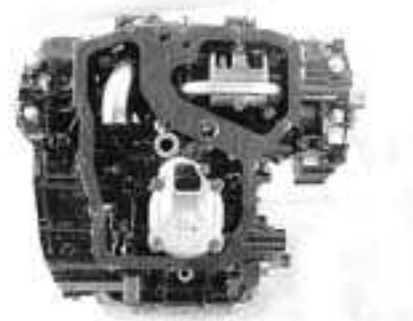

- Install the oil pan.
- Tighten the oil pan bolts diagonally to the specified torque.

#### NOTE:

Fit the gasket washer to the oil pan bolt (A).

 Oil pan bolt: 11 N·m (1.1 kgf·m, 8.1 lb-ft)

- Tighten the oil drain plug to the specified torque.

 Oil drain plug: 23 N·m (2.3 kgf·m, 17 lb-ft)

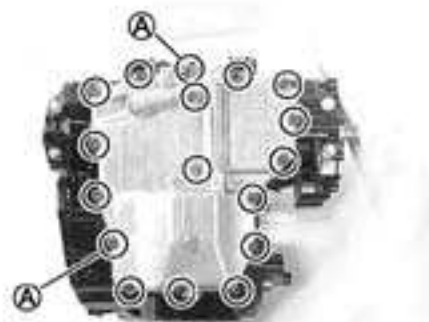

**GEAR POSITION SWITCH**

- Install the gear position switch contacts and the springs.



- Apply grease to the O-ring.

 99000-25010: SUZUKI SUPER GREASE "A"

- Install the gear position switch as shown.

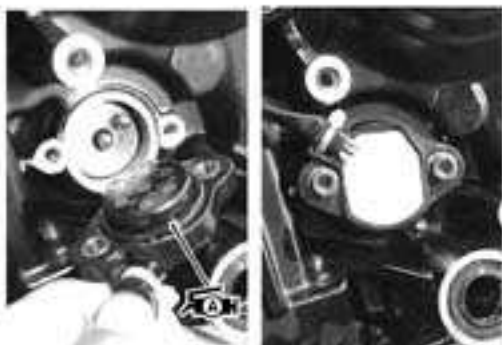
**GENERATOR**

- Degrease the tapered portion of the generator rotor and also the crankshaft. Use nonflammable cleaning solvent to wipe off oily or greasy matter and make these surfaces completely dry.



- Install the generator rotor and starter driven gear onto the crankshaft.
- Holding the generator rotor with the special tool and tighten its bolt to the specified torque.

 09930-44530: Rotor holder

 Generator rotor bolt: 160 N·m (16.0 kgf·m, 118 lb-ft)



- Install the starter idle gear and its shaft.



**GENERATOR COVER**

- Apply SUZUKI BOND lightly to the mating surfaces at the parting line between the upper and lower crankcases as shown.

 99000-31140: SUZUKI BOND "1207B"



- Install the dowel pins and new gasket.



- Install the generator cover and tighten the generator cover bolts to the specified torque.

 Generator cover bolt: 11 N·m (1.1 kgf·m, 8.1 lb-ft)

**⚠ WARNING**

Be careful not to pinch the finger between the generator cover and the crankcase.

**NOTE:**

Fit the gasket washer to the bolts .

**GEARSHIFT SYSTEM**

- Install the gearshift cam stopper, its bolt, the washer and the return spring.

 99000-32050: THREAD LOCK "1342"

 Gearshift cam stopper bolt: 10 N·m (1.0 kgf·m, 7.4 lb-ft)



- Hook the return spring end to the stopper.



- Confirm the gearshift cam stopper movement.
- Check the neutral position.
- Install the gearshift cam stopper plate after aligning the gearshift cam pin with the gearshift cam stopper plate hole.
- Apply a small quantity of **THREAD LOCK** to the gearshift cam stopper plate bolt and tighten it to the specified torque.

 **99000-32050: THREAD LOCK "1342"**

 **Gearshift cam stopper plate bolt: 10 N·m  
(1.0 kgf·m, 7.4 lb-ft)**

- Install the gearshift shaft/gearshift arm with the washers as shown.

**NOTE:**

*Pinch the gearshift arm stopper with return spring ends.*

- Install the washer and circlip.

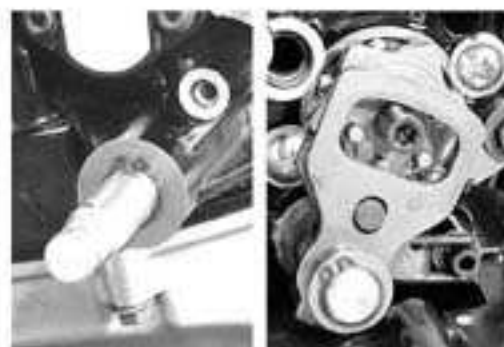

**OIL PUMP DRIVEN GEAR**

- Install the washer ① and the pin ②.

**NOTE:**

*Be careful not to drop the washer and the pin into the crankcase.*

- Install the oil pump driven gear ③.
- Install the circlip ④.

 **09900-06107: Snap ring pliers**

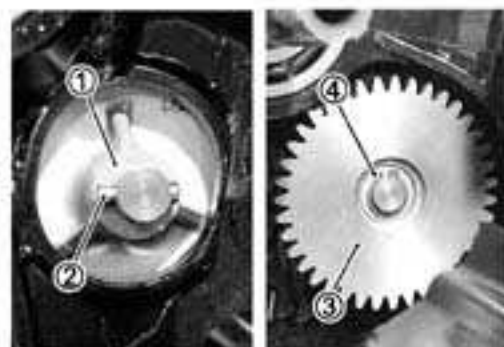

**CLUTCH**

- Install the thrust washer ① onto the countershaft.

**NOTE:**

*The chamfer side of the thrust washer faces inner side.*

- Install the needle bearing and spacer.

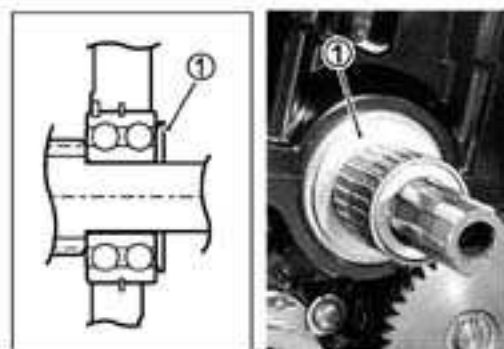

- Install the oil pump drive gear ② to the primary driven gear assembly.





- Install the primary driven gear assembly and apply engine oil to the needle bearing.
- Install the thrust washer ①.

**NOTE:**

Be sure to engage the oil pump drive and driven gears, primary drive and driven gears.

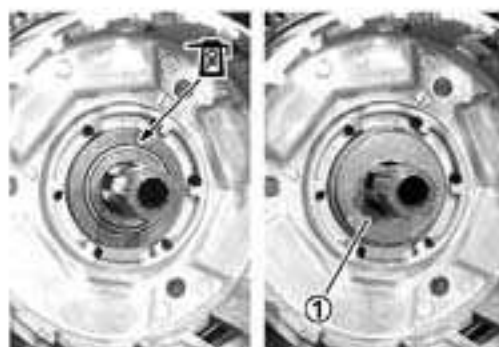

- Align the punched mark on back torque limiter driven with punched mark on drive.



- Install the clutch sleeve hub onto the countershaft.
- Install the spring washer ①.

**NOTE:**

The convex side of the washer ① faces outside.

- Install the clutch sleeve hub nut.

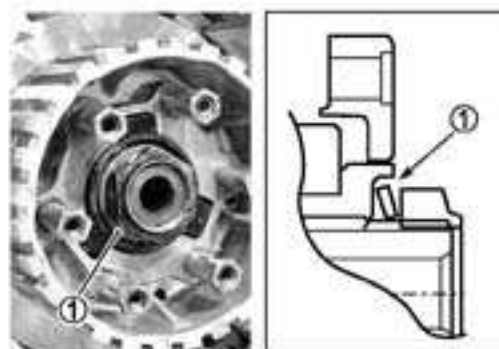

- Hold the clutch sleeve hub using the special tool.

 09920-53740: Clutch sleeve hub holder

- Tighten the clutch sleeve hub nut to the specified torque.

 Clutch sleeve hub nut: 90 N·m (9.0 kgf·m, 66 lb-ft)



- Lock the clutch sleeve hub nut with a center punch.





- Insert the spring washer seat ① and the spring washer ②.

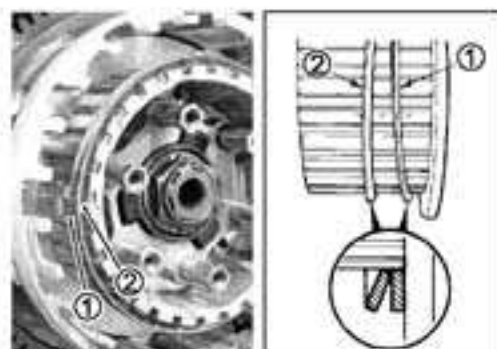

- Insert the clutch drive plates and driven plates one by one into the clutch sleeve hub in the prescribed order as shown in the illustration.

**NOTE:**

*Insert the outermost No.2 drive plate claws to the other slits of clutch housing as shown.*



Drive plate	Number	I.D.	Number of friction plate
Ⓐ No.1	8	101mm	48
Ⓑ No.2	1	101mm	36
Ⓒ No.3	1	108mm	48

- Install the clutch push rod ① into the countershaft.
- Install the clutch push piece ②, the bearing ③ and the thrust washer ④ to the countershaft.

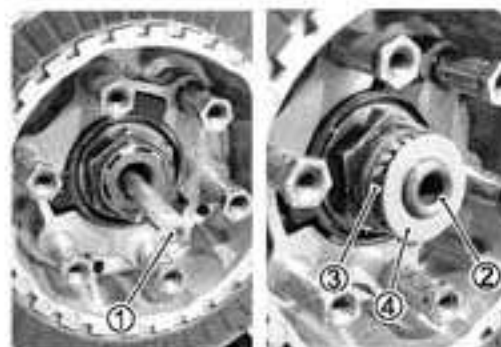

- Align the indent (B) on the clutch pressure plate with the indent (A) (either of two) on the clutch sleeve hub.

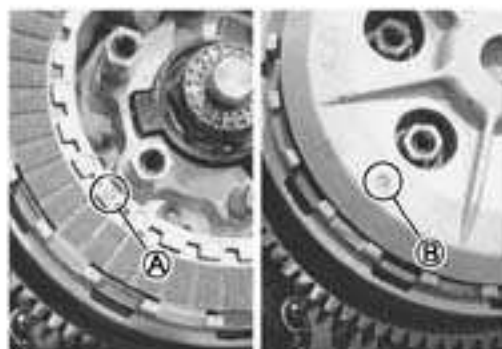

- Install the clutch springs.
- Hold the clutch housing using the special tool.

**CAUTION**

Be careful not to damage the clutch housing or clutch plates.

 09920-53740: Clutch sleeve hub holder

- Tighten the clutch spring set bolts to the specified torque.

 Clutch spring set bolt: 10 N·m (1.0 kgf·m, 7.4 lb-ft)

**NOTE:**

Tighten the clutch spring set bolts diagonally.

**CLUTCH COVER**

- Apply SUZUKI BOND lightly to the mating surfaces at the parting line between the upper, middle and lower crankcases as shown.

 99000-31140: SUZUKI BOND "1207B"

- Install the gasket and the dowel pins.

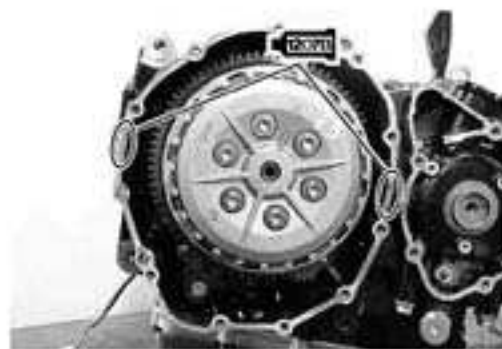

- Install the clutch cover and tighten its bolts to the specified torque.

 Clutch cover bolt: 11 N·m (1.1 kgf·m, 8.1 lb-ft)



**COOLING FAN SWITCH**

- Install the gasket and the cooling fan switch.

 Cooling fan switch: 17 N·m (1.7 kgf·m, 13 lb-ft)

**OIL FILTER**

- Install the oil filter using the special tool. (☞2-13)

 09915-40610: Oil filter wrench

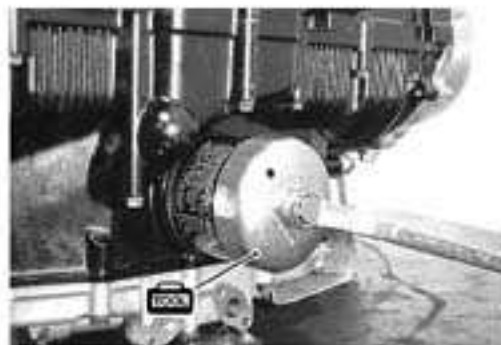
**OIL PRESSURE SWITCH**

- Install the oil pressure switch and tighten it to the specified torque.

 Oil pressure switch: 14 N·m (1.4 kgf·m, 10.0 lb-ft)

**SIGNAL GENERATOR**

- Install the signal generator.



- Align the pin of crankshaft with the slit of the rotor.



- Hold the rotor and tighten the signal generator rotor bolt to the specified torque.

 Signal generator rotor bolt: 25 N·m (2.5 kgf·m, 18 lb-ft)



- Pass the signal generator lead wire through the crankcase hole.



#### BREATHER COVER

- Install the gasket.
- Install the breather cover.

 Breather cover bolt: 10 N·m (1.0 kgf·m, 7.4 lb-ft)

#### NOTE:

Install the engine ground lead wire and clamp to the bolt .



#### STARTER MOTOR

- Apply grease to the O-ring and install the starter motor.

 99000-25010: SUZUKI SUPER GREASE "A"

 Starter motor mounting bolt: 6 N·m (0.6 kgf·m, 4.4 lb-ft)

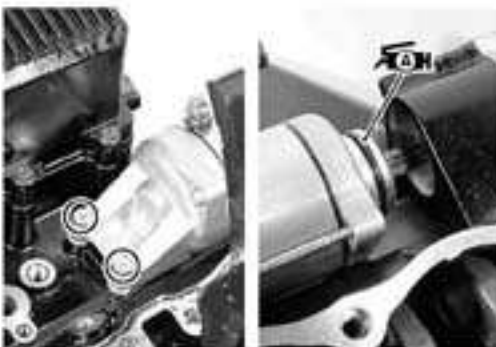

#### OIL TEMPERATURE SENSOR

- Apply grease to the O-ring and install the oil temperature sensor.

 Oil temperature sensor bolt: 10 N·m (1.0 kgf·m, 7.4 lb-ft)



**PISTON**

- Install the piston rings in the order of oil ring, 2nd ring and 1st ring.
- The first member to go into the oil ring groove is a spacer ①. After placing the spacer, fit the two side rails ②.

**NOTE:**

Side designations, top and bottom, are not applied to the spacer and side rails: you can position each either way.

**CAUTION**

**When installing the spacer, be careful not to allow its two ends to overlap in the groove.**

- Install the 2nd ring and the 1st ring.

**NOTE:**

1st ring and 2nd ring differ in shape.

- 1st ring and 2nd ring have letters "N" and "2N" marked on the side. Be sure to bring the marked side to the top when fitting them to the piston.
- Position the gaps of the three rings as shown. Before inserting each piston into the cylinder, check that the gaps are so located.
  - Ⓐ :2nd ring/Lower side rail
  - Ⓑ :Upper side rail
  - Ⓒ :Top ring/Spacer

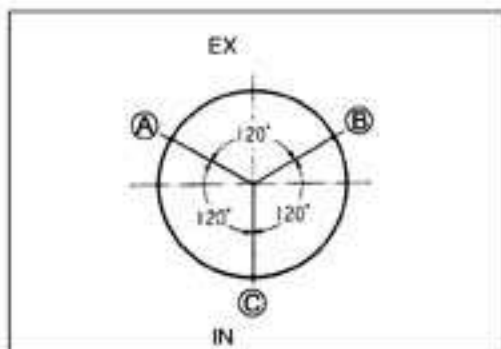
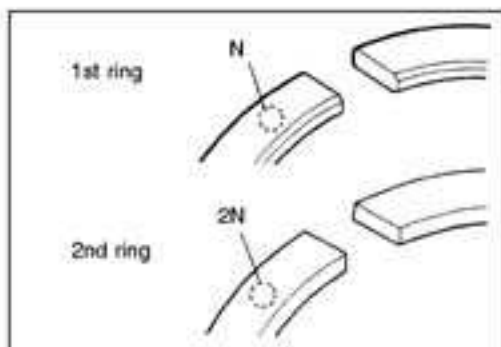
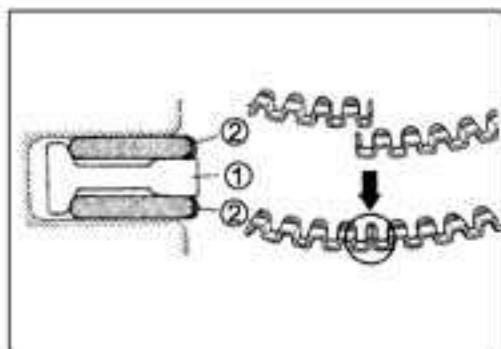
**PISTON AND CONROD**

- When installing the pistons, the indent on the piston head must be faced to exhaust side.
- Rub a small quantity of molybdenum oil solution onto each piston pin.

**MOLYBDENUM OIL**

- Install the pistons.

**NOTE:**

Be sure to install the pistons in the cylinders from which they were removed in disassembly, refer to the cylinder numbers, "1" through "4", scribed on the piston.

- Install the piston pin circlips.

**CAUTION**

**Use new piston pin circlips to prevent circlip failure which will occur with a bend one.**

**NOTE:**

End gap of the circlip should not be aligned with the cutaway in the piston pin bore.

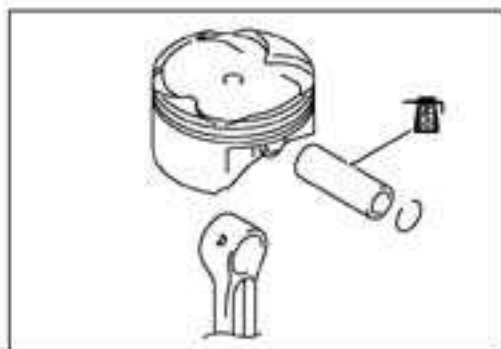

### CYLINDER

- Install the dowel pins and gasket.
- Apply engine oil to the sliding surface of the pistons and cylinder walls.



- Set the special tools to the No.2 and No.3 pistons, and insert them into the cylinder block.

 **09916-74521: Holder body**  
**09916-54540: Band**

#### NOTE:

*Do not over tighten the special tool bands or the pistons entry into the cylinders will be difficult.*

- After inserting the No.2 and No.3 pistons in place, insert the No.1 and No.4 pistons.
- Tighten cylinder nut  temporarily.



### CYLINDER HEAD

- Apply grease to the O-rings and insert the oil return pipes to the crankcase.

 **99000-25010: SUZUKI SUPER GREASE "A"**



- Fit the dowel pins and the new cylinder head gasket to the cylinder.





- Place the cylinder head on the cylinder.
- Apply engine oil to the threads of cylinder head bolt and the copper washers.

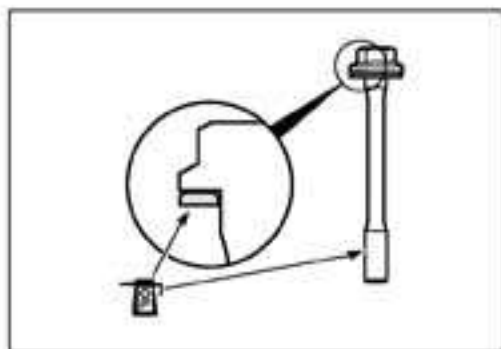

- Install the cylinder head plate ① and tighten the cylinder head bolts and nuts (M10) to the specified two-step torque with a torque wrench sequentially and diagonally.

**🔧 Cylinder head bolt/nut (M10):**

**Initial: 25 N·m (2.5 kgf·m, 18 lb-ft)**

**Final: 37 N·m (3.7 kgf·m, 27 lb-ft)**

**NOTE:**

Fit the copper washer to the bolt/nut ①.

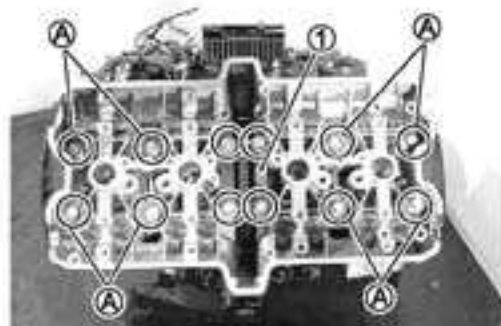

- Tighten the cylinder head bolts (M6) and the cylinder nut ②.

**🔧 Cylinder head bolt (M6): 10 N·m (10 kgf·m, 7.4 lb-ft)**

**Cylinder nut: 10 N·m (1.0 kgf·m, 7.4 lb-ft)**



- Install the cam chain guide.





- Install the cylinder head oil hose.

**🔧** Cylinder head oil hose union bolt:  
20 N·m (2.0 kgf·m, 15 lb-ft)

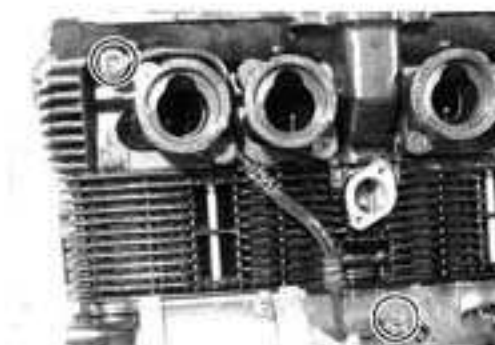

- Install the oil pipe with the white paint facing exhaust side.
- Install and tighten the oil pipe bolts with the washers.

**🔧** Oil pipe bolt: 10 N·m (1.0 kgf·m, 7.4 lb-ft)



### CAMSHAFT

- Turn the crankshaft clockwise with the box wrench and align the "T" line on the signal generator rotor with the tip of the signal generator rotor sensor while keeping the cam chain pulled upward.

#### CAUTION

**Pull the cam chain upward, or the chain will be caught between crankcase and cam drive sprocket.**



- The camshafts are identified by the embossed letters.

#### NOTE:

*Before installing the camshaft, check that the tappets are installed correctly.*

- Pull the cam chain lightly.
- Set the exhaust camshaft so that the arrow marked "1" is aligned with the surface of the cylinder head.



- The other arrow marked "2" should now be pointing straight up. Starting from the roller pin that is directly above the arrow marked "2", count out 24 roller pins.
- Engage the 24 roller pin on the cam chain with the arrow marked "3" on the intake sprocket.

#### NOTE:

*The cam chain should now be on all three sprockets. Be careful not to move the crankshaft until the camshaft journal holders and cam chain tension adjuster are secured.*



## POSITION OF CAMSHAFTS AND CAM SPROCKETS

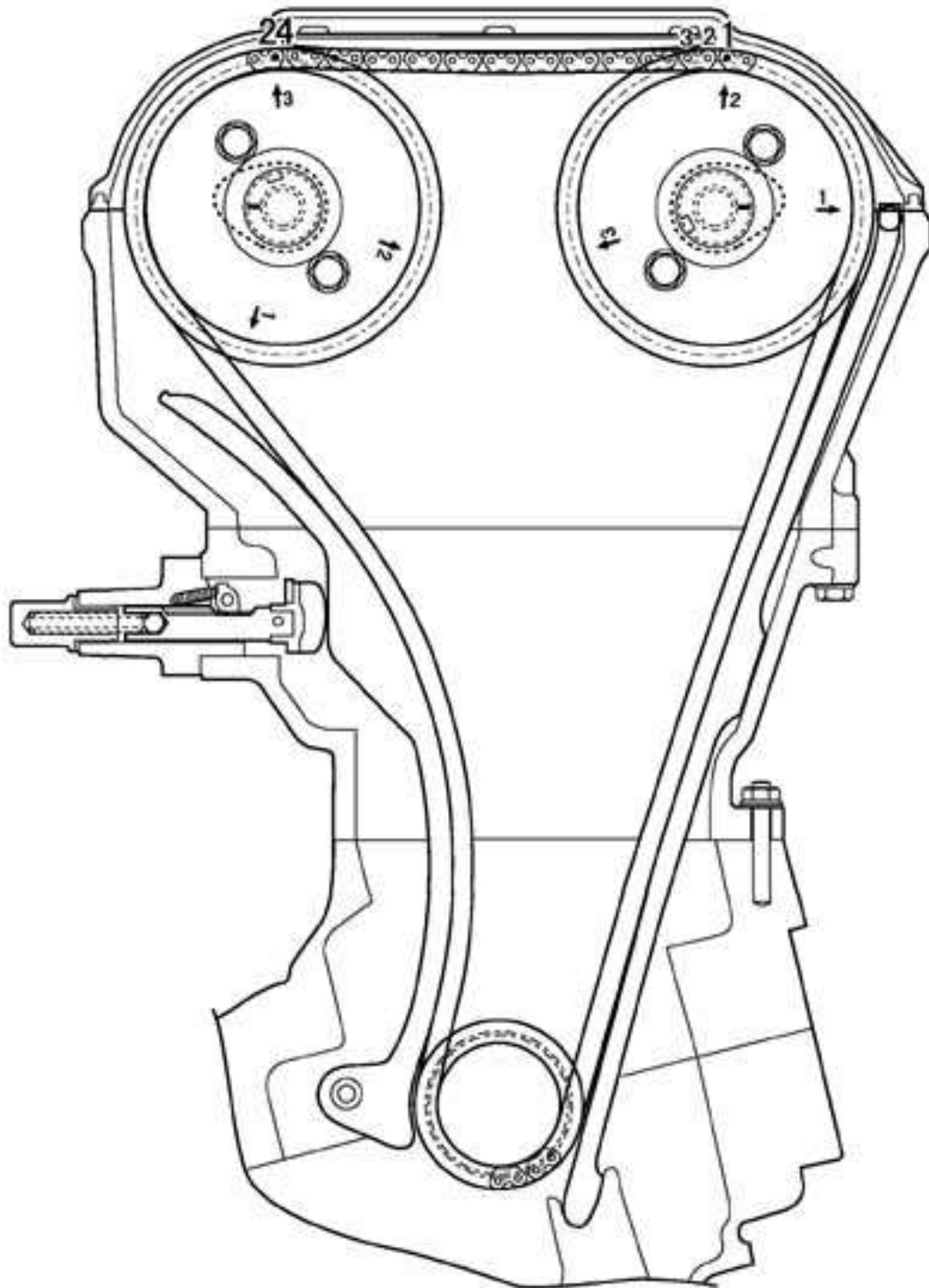

- Apply molybdenum oil solution to journals and cam faces.

### MOLYBDENUM OIL SOLUTION

- Install each dowel pin.

- Install the camshaft journal holders by aligning the embossed letters on the camshaft journal holders with the embossed letters on the cylinder head.
- Fasten the camshaft journal holders evenly by tightening the camshaft journal holder bolts sequentially and diagonally.

 **Camshaft journal holder bolt: 10 N·m  
(1.0 kgf·m, 7.4 lb-ft)**

#### NOTE:

*Damage to head or camshaft journal holder thrust surfaces may result if the camshaft journal holders are not drawn down evenly.*

#### Cam chain tension adjuster

- Retract the push rod by pushing the stopper.
- Install the cam chain tension adjuster with new gasket.

 **Cam chain tension adjuster mounting bolt: 10 N·m  
(1.0 kgf·m, 7.4 lb-ft)**

- Install the steel ball, the spring, the gasket washer and cam chain tension adjuster cap to the cam chain tension adjuster.

 **Cam chain tension adjuster cap:  
35 N·m (3.5 kgf·m, 26 lb-ft)**

#### NOTE:

*Click sound is heard when the cam chain tension adjuster cap bolt is installed.*

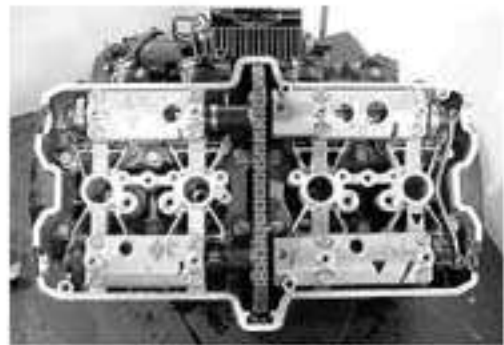
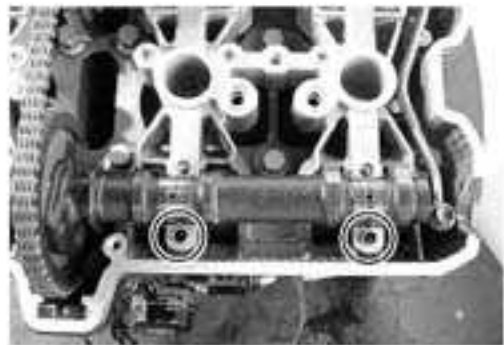
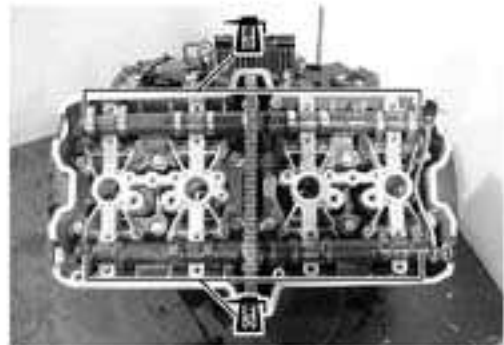

- After installing the cam chain tension adjuster, check to be sure that the adjuster work properly by checking the slack of cam chain.
- After installing the cam chain tension adjuster, rotate the crankshaft (some turns), and recheck the positions of the camshafts. (☞ 3-75)
- Install the cam chain guide.

 Cam chain guide bolt: 10 N·m (1.0 kgf-m, 7.4 lb-ft)

#### SIGNAL GENERATOR COVER

- Apply SUZUKI BOND to the grommet and the crankcase mating surface.

 99000-31140: SUZUKI BOND "1207B"

- Install the gasket.

- Install the signal generator cover.

 Signal generator cover bolt: 11 N·m (1.1 kgf-m, 8.0 lb-ft)

#### NOTE:

Fit the gasket washer to the starter clutch cover bolt (A) as shown.

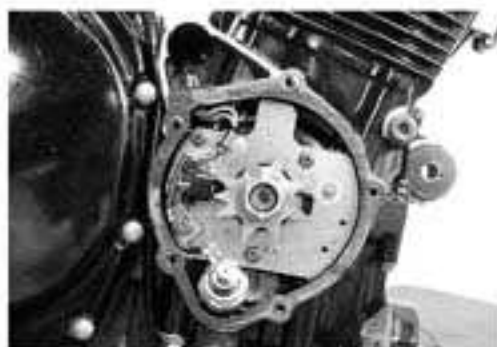
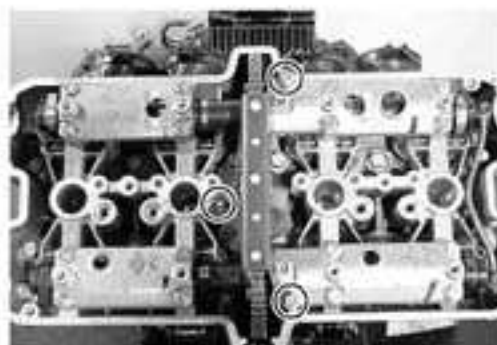

**CYLINDER HEAD COVER**

- Pour engine oil in each oil pocket in the cylinder head.

**NOTE:**

Be sure to check the valve clearance. (☞ 2-6)

- Install the new gaskets to the cylinder head cover.
- Apply SUZUKI BOND to the cam end caps of the gaskets as shown.

 **99000-31230: SUZUKI BOND "1216B"**

- Place the cylinder head cover on the cylinder head.
- Fit the new gaskets to head cover bolts (8 mm).
- Tighten the head cover bolts to the specified torque.

 **Head cover bolt (8 mm): 20 N·m (2.0 kgf·m, 15 lb-ft)**

- Apply a small quantity of engine oil to the gasket.
- Tighten the head cover bolts (7 mm) to the specified torque.

 **Head cover bolt (7 mm): 14 N·m (1.4 kgf·m, 10.0 lb-ft)**

- Apply grease to the O-ring and install the oil hose.

 **Oil hose union bolt: 10 N·m (10 kgf·m, 7.4 lb-ft)**

 **99000-25010: SUZUKI SUPER GREASE "A"**

**PAIR REED VALVE**

- Install the PAIR reed valve and its cover.

 **PAIR reed valve cover bolt: 10 N·m (1.0 kgf·m, 7.4 lb-ft)**

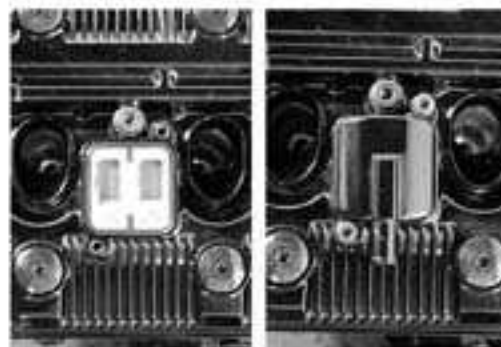
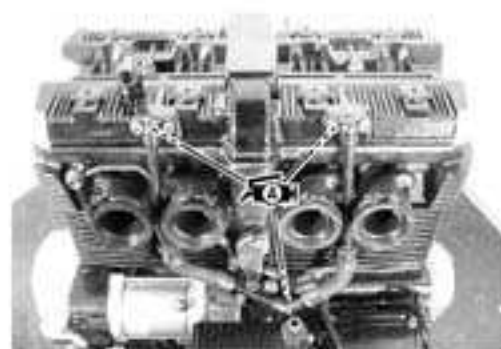
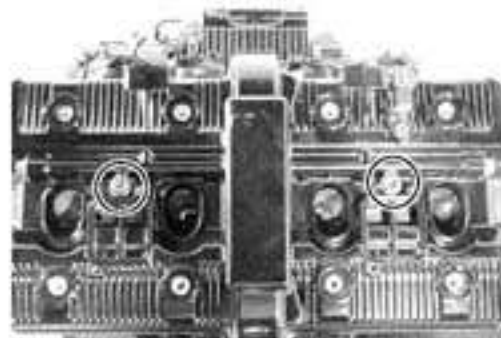
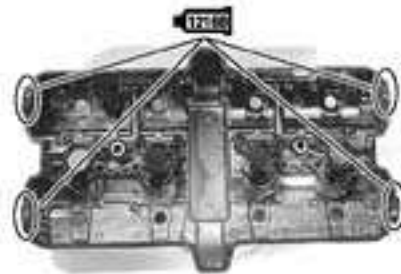



# FI SYSTEM

## CONTENTS

<b>PRECAUTIONS IN SERVICING</b> .....	4- 2
<b>FI SYSTEM TECHNICAL FEATURES</b> .....	4- 8
<b>INJECTION TIME</b> .....	4- 8
<b>COMPENSATION OF INJECTION TIME</b> .....	4- 9
<b>INJECTION STOP CONTROL</b> .....	4- 9
<b>FUEL DELIVERY SYSTEM</b> .....	4-10
<b>FUEL PUMP</b> .....	4-11
<b>FUEL PRESSURE REGULATOR</b> .....	4-12
<b>FUEL INJECTOR</b> .....	4-12
<b>FUEL PUMP CONTROL SYSTEM</b> .....	4-13
<b>ECM (FI CONTROL UNIT)</b> .....	4-14
<b>INJECTION TIMING</b> .....	4-14
<b>SENSORS</b> .....	4-15
<b>FI SYSTEM PARTS LOCATION</b> .....	4-19
<b>FI SYSTEM DIAGRAM</b> .....	4-21
<b>FI SYSTEM WIRING DIAGRAM</b> .....	4-22
<b>SELF-DIAGNOSIS FUNCTION</b> .....	4-23
<b>USER MODE</b> .....	4-23
<b>DEALER MODE</b> .....	4-24
<b>FAIL-SAFE FUNCTION</b> .....	4-26
<b>FI SYSTEM TROUBLESHOOTING</b> .....	4-27
<b>CUSTOMER COMPLAINT ANALYSIS</b> .....	4-27
<b>SELF-DIAGNOSTIC PROCEDURES</b> .....	4-28
<b>SELF-DIAGNOSIS RESET PROCEDURE</b> .....	4-28
<b>MALFUNCTION CODE AND DEFECTIVE CONDITION</b> .....	4-29
<b>"C11" CMP SENSOR CIRCUIT MALFUNCTION</b> .....	4-31
<b>"C12" CKP SENSOR CIRCUIT MALFUNCTION</b> .....	4-32
<b>"C13" IAP SENSOR CIRCUIT MALFUNCTION</b> .....	4-33
<b>"C14" TP SENSOR CIRCUIT MALFUNCTION</b> .....	4-35
<b>"C15" EOT SENSOR CIRCUIT MALFUNCTION</b> .....	4-37
<b>"C21" IAT SENSOR CIRCUIT MALFUNCTION</b> .....	4-38
<b>"C22" AP SENSOR CIRCUIT MALFUNCTION</b> .....	4-39
<b>"C23" TO SENSOR CIRCUIT MALFUNCTION</b> .....	4-41
<b>"C24" or "C25" IGNITION SYSTEM MALFUNCTION</b> .....	4-42
<b>"C28" STV ACTUATOR CIRCUIT MALFUNCTION</b> .....	4-42
<b>"C29" STP SENSOR CIRCUIT MALFUNCTION</b> .....	4-43
<b>"C31" GEAR POSITION SWITCH CIRCUIT MALFUNCTION</b> .....	4-45
<b>"C32", "C33", "C34" or "C35" FUEL INJECTION MALFUNCTION</b> .....	4-46
<b>"C41" FP RELAY CIRCUIT MALFUNCTION</b> .....	4-47
<b>"C42" IG SWITCH CIRCUIT MALFUNCTION</b> .....	4-47

<b>FUEL SYSTEM</b> .....	4-48
<b>FUEL TANK REMOVAL</b> .....	4-48
<b>FUEL TANK INSTALLATION</b> .....	4-48
<b>FUEL PRESSURE INSPECTION</b> .....	4-49
<b>FUEL PUMP INSPECTION</b> .....	4-50
<b>FUEL PUMP RELAY INSPECTION</b> .....	4-51
<b>FUEL PUMP AND FUEL FILTER REMOVAL</b> .....	4-51
<b>FUEL MESH FILTER INSPECTION AND CLEANING</b> .....	4-52
<b>FUEL PUMP AND FUEL MESH FILTER INSTALLATION</b> .....	4-53
<b>THROTTLE BODY AND STV ACTUATOR</b> .....	4-54
<b>CONSTRUCTION</b> .....	4-54
<b>THROTTLE BODY REMOVAL</b> .....	4-55
<b>THROTTLE BODY DISASSEMBLY</b> .....	4-56
<b>THROTTLE BODY CLEANING</b> .....	4-59
<b>INSPECTION</b> .....	4-59
<b>THROTTLE BODY REASSEMBLY</b> .....	4-59
<b>STP SENSOR ADJUSTMENT</b> .....	4-62
<b>TP SENSOR ADJUSTMENT</b> .....	4-64
<b>THROTTLE BODY INSTALLATION</b> .....	4-64
<b>FUEL INJECTOR INSPECTION</b> .....	4-64
<b>FUEL INJECTOR REMOVAL</b> .....	4-64
<b>FUEL INJECTOR INSTALLATION</b> .....	4-64
<b>FAST IDLE INSPECTION</b> .....	4-65
<b>FAST IDLE ADJUSTMENT</b> .....	4-65
<b>THROTTLE VALVE SYNCHRONIZATION</b> .....	4-66
<b>THROTTLE CABLE ADJUSTMENT</b> .....	4-66
<b>SENSORS</b> .....	4-67
<b>IAP SENSOR INSPECTION</b> .....	4-67
<b>IAP SENSOR REMOVAL/INSTALLATION</b> .....	4-67
<b>TP SENSOR INSPECTION</b> .....	4-67
<b>TP SENSOR REMOVAL/INSTALLATION</b> .....	4-67
<b>STP SENSOR INSPECTION</b> .....	4-67
<b>STP SENSOR REMOVAL/INSTALLATION</b> .....	4-67
<b>CKP SENSOR INSPECTION</b> .....	4-67
<b>CKP SENSOR REMOVAL/INSTALLATION</b> .....	4-67
<b>CMP SENSOR INSPECTION</b> .....	4-68
<b>CMP SENSOR REMOVAL/INSTALLATION</b> .....	4-68
<b>IAT SENSOR INSPECTION</b> .....	4-68
<b>IAT SENSOR REMOVAL/INSTALLATION</b> .....	4-68
<b>EOT SENSOR INSPECTION</b> .....	4-68
<b>EOT SENSOR REMOVAL/INSTALLATION</b> .....	4-68
<b>AP SENSOR INSPECTION</b> .....	4-68
<b>AP SENSOR REMOVAL/INSTALLATION</b> .....	4-68
<b>TO SENSOR INSPECTION</b> .....	4-68
<b>TO SENSOR REMOVAL/INSTALLATION</b> .....	4-68



## PRECAUTIONS IN SERVICING

When handling the FI component parts or servicing the FI system, observe the following points for the safety of the system.

### CONNECTOR/COUPLER

- When connecting a connector, be sure to push it in until a click is felt.
  - With a lock type coupler, be sure to release the lock when disconnecting, and push it in fully till the lock works when connecting it.
  - When disconnecting the coupler, be sure to hold the coupler body and do not pull the lead wires.
  - Inspect each terminal on the connector/coupler for looseness or bending.
  - Inspect each terminal for corrosion and contamination. The terminals must be clean and free of any foreign material which could impede proper terminal contact.
- 
- Inspect each lead wire circuit for poor connection by shaking it by hand lightly. If any abnormal condition is found, repair or replace.
- 
- When taking measurements at electrical connectors using a tester probe, be sure to insert the probe from the wire harness side (backside) of the connector/coupler.
- 
- When connecting meter probe from the terminal side of the coupler (connection from harness side not being possible), use extra care not to force and cause the male terminal to bend or the female terminal to open. Connect the probe as shown to avoid opening of female terminal. Never push in the probe where male terminal is supposed to fit.
  - Check the male connector for bend and female connector for excessive opening. Also check the coupler for locking (looseness), corrosion, dust, etc.

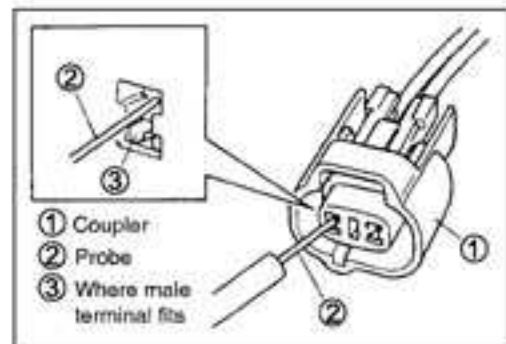
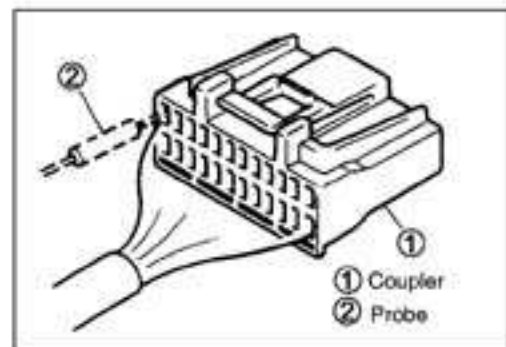
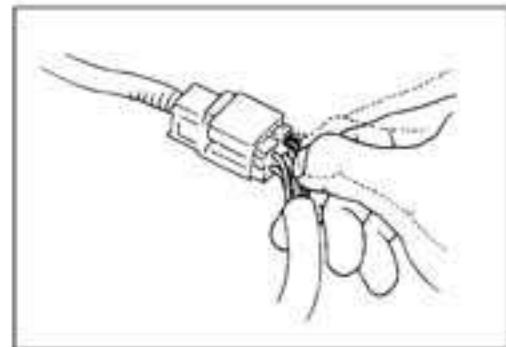
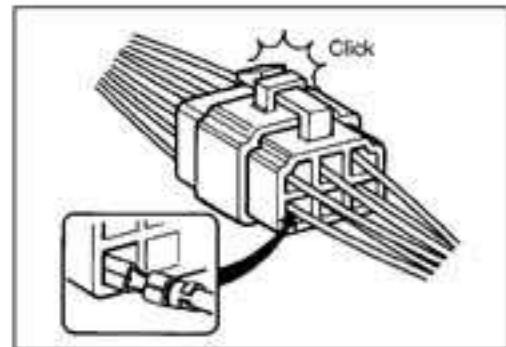
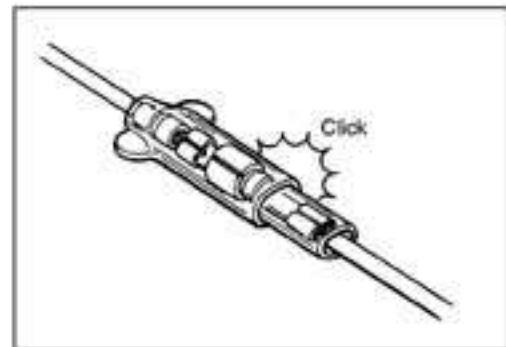

## FUSE

- When a fuse blows, always investigate the cause, correct it and then replace the fuse.
- Do not use a fuse of a different capacity.
- Do not use wire or any other substitute for the fuse.

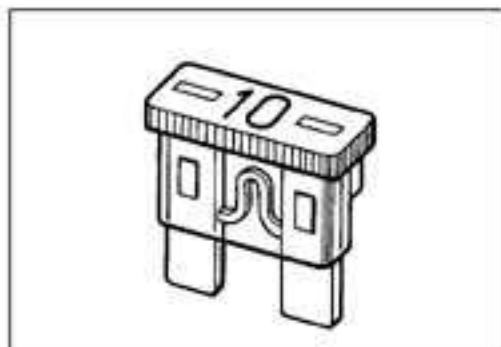

## ECM/VARIOUS SENSORS

- Since each component is a high-precision part, great care should be taken not to apply any sharp impacts during removal and installation.

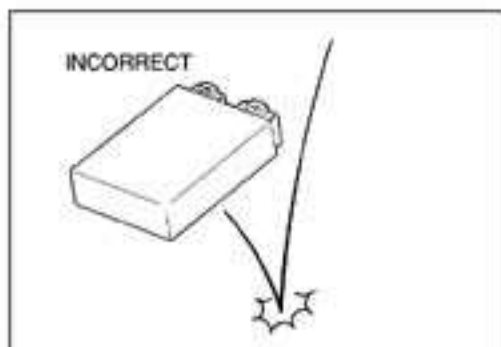

- Be careful not to touch the electrical terminals of the ECM. The static electricity from your body may damage this part.

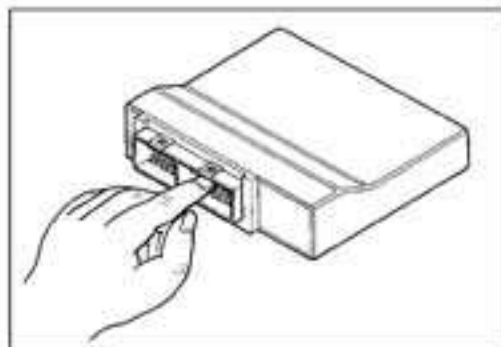

- When disconnecting and connecting the ECM couplers, make sure to turn OFF the ignition switch, or electronic parts may get damaged.

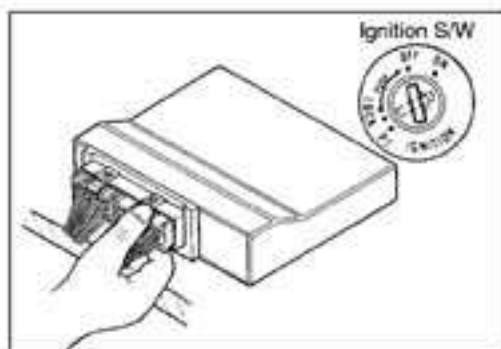

- Battery connection in reverse polarity is strictly prohibited. Such a wrong connection will damage the components of the FI system instantly when reverse power is applied.

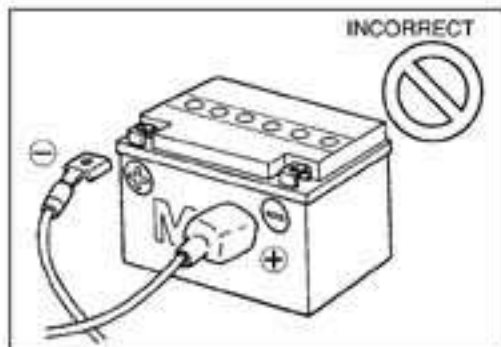

- Removing any battery terminal of a running engine is strictly prohibited.

The moment such removal is made, damaging counter electro-motive force will be applied to the ECM which may result in serious damage.

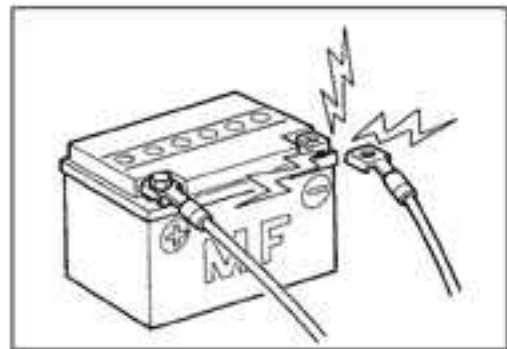

- Before measuring voltage at each terminal, check to make sure that battery voltage is 11V or higher. Terminal voltage check at low battery voltage will lead to erroneous diagnosis.

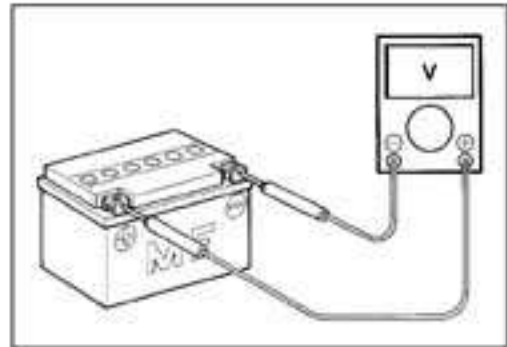

- Never connect any tester (voltmeter, ohmmeter, or whatever) to the ECM when its coupler is disconnected. Otherwise, damage to ECM may result.
- Never connect an ohmmeter to the ECM with its coupler connected. If attempted, damage to ECM or sensors may result.
- Be sure to use a specified voltmeter/ohmmeter. Otherwise, accurate measurements may not be obtained and personal injury may result.

## ELECTRICAL CIRCUIT INSPECTION PROCEDURE

While there are various methods for electrical circuit inspection, described here is a general method to check for open and short circuit using an ohmmeter and a voltmeter.

### OPEN CIRCUIT CHECK

Possible causes for the open circuit are as follows. As the cause can exist in the connector/coupler or terminal, they need to be checked carefully.

- Loose connection of connector/coupler
- Poor contact of terminal (due to dirt, corrosion or rust, poor contact tension, entry of foreign object etc.)
- Wire harness being open
- Poor terminal-to-wire connection

- Disconnect the negative cable from the battery.
- Check each connector/coupler at both ends of the circuit being checked for loose connection. Also check for condition of the coupler lock if equipped.

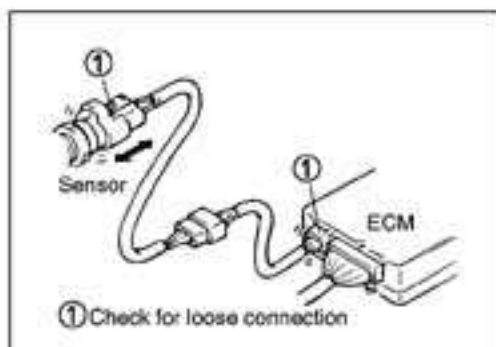

- Using a test male terminal, check the female terminals of the circuit being checked for contact tension.

Check each terminal visually for poor contact (possibly caused by dirt, corrosion, rust, entry of foreign object, etc.). At the same time, check to make sure that each terminal is fully inserted in the coupler and locked.

If contact tension is not enough, rectify the contact to increase tension or replace.

The terminals must be clean and free of any foreign material which could impede proper terminal contact.

- Using continuity inspect or voltage check procedure as described below, inspect the wire harness terminals for open circuit and poor connection. Locate abnormality, if any.

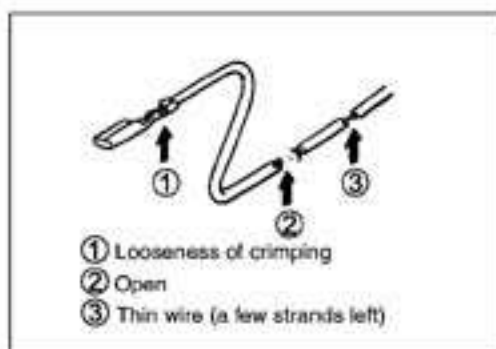
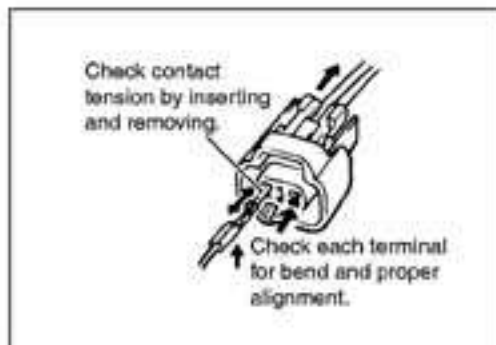

### Continuity check

- Measure resistance across coupler (B) (between (A) and (C) in the figure).

If no continuity is indicated (infinity or over limit), the circuit is open between terminals (A) and (C).

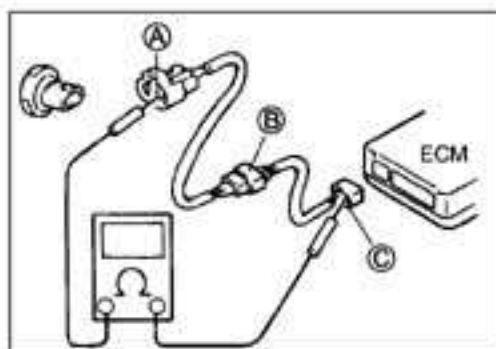

- Disconnect the coupler (B) and measure resistance between couplers (A) and (B).

If no continuity is indicated, the circuit is open between couplers (A) and (B). If continuity is indicated, there is an open circuit between couplers (B') and (C) or an abnormality in coupler (B') or coupler (C).

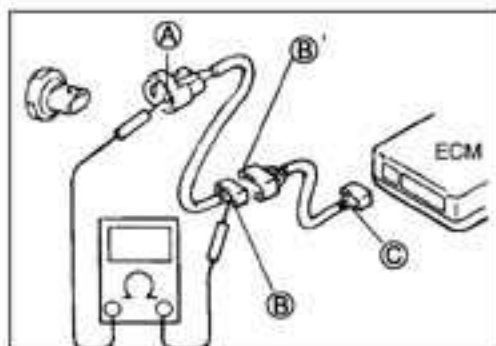

**VOLTAGE CHECK**

If voltage is supplied to the circuit being checked, voltage check can be used as circuit check.

- With all connectors/couplers connected and voltage applied to the circuit being checked, measure voltage between each terminal and body ground.

If measurements were taken as shown in the figure at the right and results are as listed below, it means that the circuit is open between terminals (A) and (B).

**Voltage Between:**

- (C) and body ground: Approx. 5V
- (B) and body ground: Approx. 5V
- (A) and body ground: 0V

Also, if measured values are as listed below, a resistance (abnormality) exists which causes the voltage drop in the circuit between terminals (A) and (B).

**Voltage Between:**

- (C) and body ground: Approx. 5V
  - (B) and body ground: Approx. 5V
  - (A) and body ground: Approx. 3V
- } 2V voltage drop

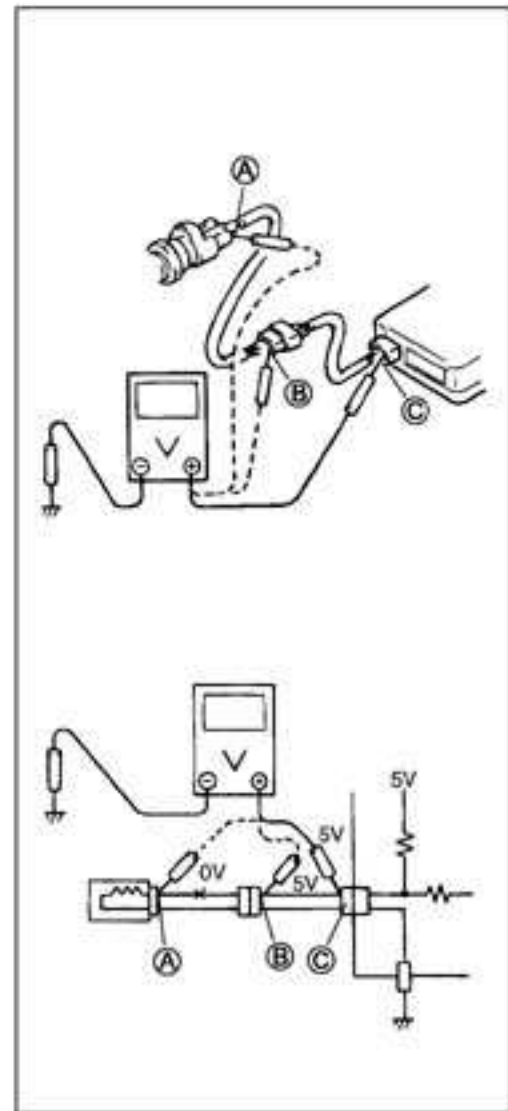
**SHORT CIRCUIT CHECK (WIRE HARNESS TO GROUND)**

- Disconnect the negative cable from the battery.
- Disconnect the connectors/couplers at both ends of the circuit to be checked.

**NOTE:**

If the circuit to be checked branches to other parts as shown, disconnect all connectors/couplers of those parts. Otherwise, diagnosis will be misled.

- Measure resistance between terminal at one end of circuit (A terminal in figure) and body ground. If continuity is indicated, there is a short circuit to ground between terminals (A) and (C).

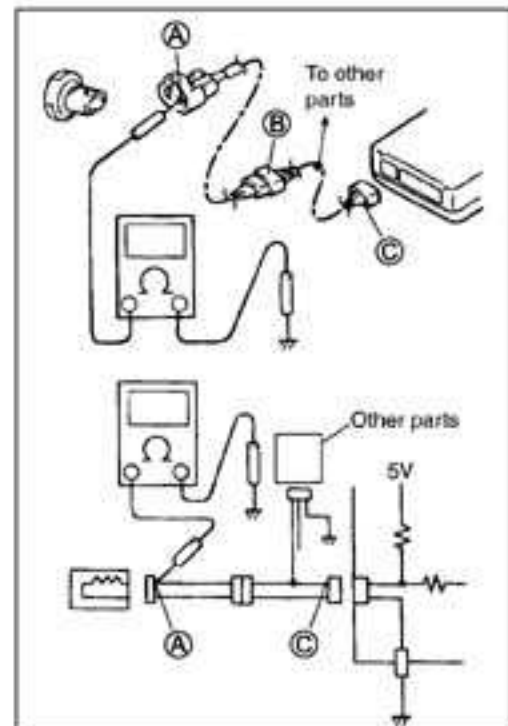

- Disconnect the connector/coupler included in circuit (coupler ②) and measure resistance between terminal ① and body ground. If continuity is indicated, the circuit is shorted to the ground between terminals ① and ②.

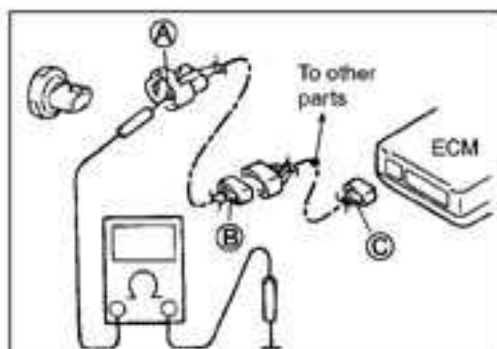

## USING TESTERS

- Use the Suzuki multi-circuit tester (09900-25008).
- Use well-charged batteries in the tester.
- Be sure to set the tester to the correct testing range.

### Using the tester

- Incorrectly connecting the ⊕ and ⊖ probes may cause the inside of the tester to burnout.
- If the voltage and current are not known, make measurements using the highest range.
- When measuring the resistance with the multi-circuit tester, ∞ will be shown as 10.00MΩ and "1" flashes in the display.
- Check that no voltage is applied before making the measurement. If voltage is applied, the tester may be damaged.
- After using the tester, turn the power off.

### 09900-25008: Multi-circuit tester

#### NOTE:

- When connecting the multi circuit tester, install fine copper wires (O.D is below 0.5 mm) to the back side of the lead wire coupler and connect the probes of tester to them.
- Use a fine copper wire, the outer diameter being below 0.5 mm, to prevent the rubber of the water proof coupler from damage.



## FI SYSTEM TECHNICAL FEATURES

### INJECTION TIME (INJECTION VOLUME)

The factors to determine the injection time include the basic fuel injection time which is calculated on the basis of the intake air pressure, engine speed and throttle opening angle, and various compensations which are determined according to the signals from various sensors that detect the engine and driving conditions.

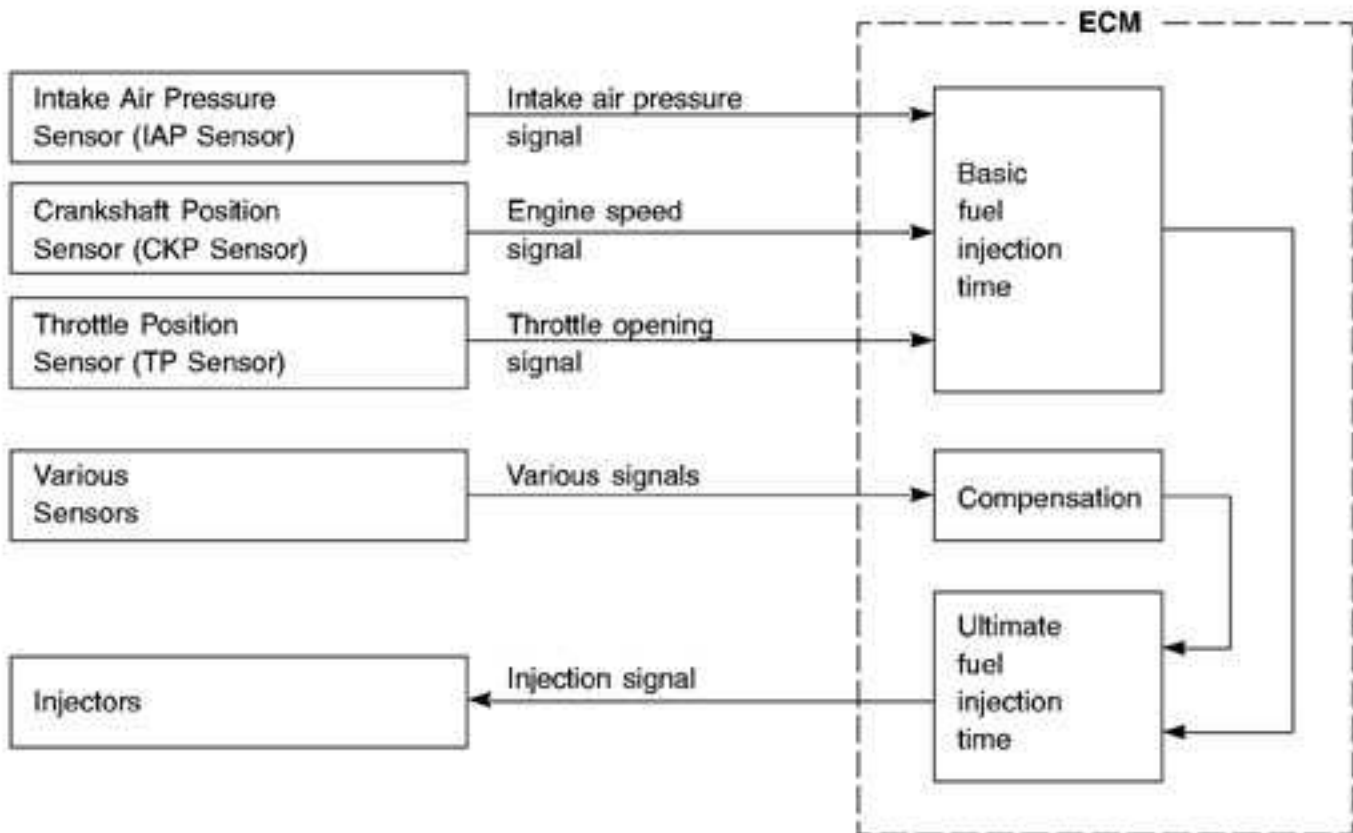



## COMPENSATION OF INJECTION TIME (VOLUME)

The following different signals are output from the respective sensors for compensation of the fuel injection time (volume).

SIGNAL	DESCRIPTION
ATMOSPHERIC PRESSURE SENSOR SIGNAL	When atmospheric pressure is low, the sensor sends the signal to the ECM and reduce the injection time (volume).
ENGINE OIL TEMPERATURE SENSOR SIGNAL	When engine oil temperature is low, injection time (volume) is increased.
INTAKE AIR TEMPERATURE SENSOR SIGNAL	When intake air temperature is low, injection time (volume) is increased.
BATTERY VOLTAGE SIGNAL	ECM operates on the battery voltage and at the same time, it monitors the voltage signal for compensation of the fuel injection time (volume). A longer injection time is needed to adjust injection volume in the case of low voltage.
ENGINE RPM SIGNAL	At high speed, the injection time (volume) is increased.
STARTING SIGNAL	When starting engine, additional fuel is injected during cranking engine.
ACCELERATION SIGNAL/ DECELERATION SIGNAL	During acceleration, the fuel injection time (volume) is increased, in accordance with the throttle opening speed and engine rpm. During deceleration, the fuel injection time (volume) is decreased.

## INJECTION STOP CONTROL

SIGNAL	DESCRIPTION
TIP OVER SENSOR SIGNAL (FUEL SHUT-OFF)	When the motorcycle tips over, the tip over sensor sends a signal to the ECM. Then, this signal cuts OFF current supplied to the fuel pump, fuel injectors and ignition coils.
OVER-REV. LIMITER SIGNAL	The fuel injectors stop operation when engine rpm reaches rev. limit rpm.

## FUEL DELIVERY SYSTEM

The fuel delivery system consists of the fuel tank, fuel pump, fuel filters, fuel feed hose, fuel delivery pipe (including fuel injectors) and fuel pressure regulator. There is no fuel return hose. The fuel in the fuel tank is pumped up by the fuel pump and pressurized fuel to flow into the injector installed in the fuel delivery pipe. Fuel pressure is regulated by the fuel pressure regulator. As the fuel pressure applied to the fuel injector (the fuel pressure in the fuel delivery pipe) is always kept absolute fuel pressure of 300 kPa (3.0 kgf/cm<sup>2</sup>, 43 psi), the fuel is injected into the throttle body in conic dispersion when the injector opens according to the injection signal from the ECM.

The fuel relieved by the fuel pressure regulator flows out to the fuel tank.

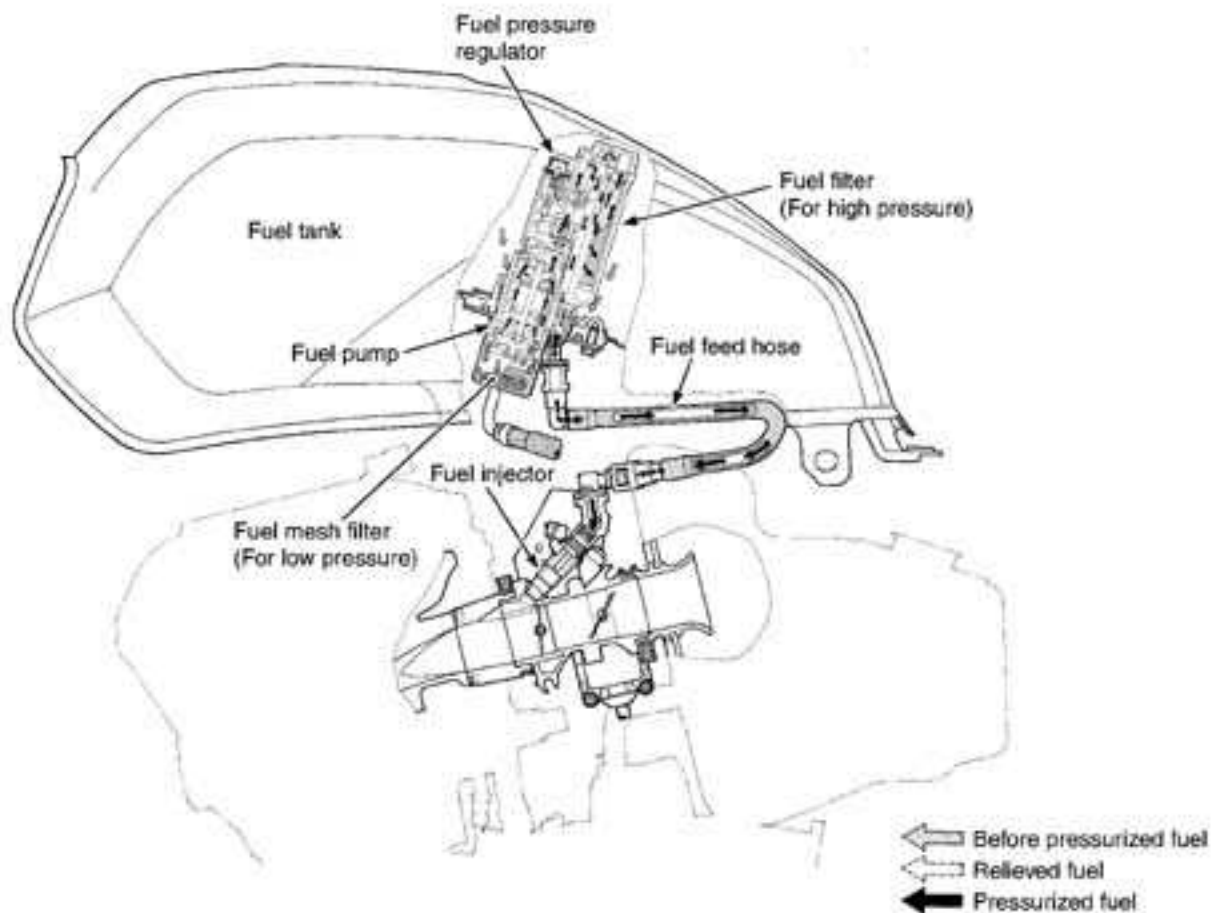

## FUEL PUMP

The electric fuel pump is mounted at the bottom of the fuel tank, which consists of the armature, magnet, impeller, brush, check valve and relief valve. The ECM controls its ON/OFF operation as controlled under the FUEL PUMP CONTROL SYSTEM.

When electrical energy is supplied to the fuel pump, the motor in the pump runs and so does the impeller. This causes a pressure difference to occur between both sides of the impeller as there are many grooves around it. Then the fuel is drawn through the inlet port, and with its pressure increased, it is discharged through the outlet port. The fuel pump has a check valve to keep some pressure in the fuel feed hose even when the fuel pump is stopped. Also, the relief valve is equipped in the fuel pump, which releases pressurized fuel to the fuel tank when the outlet of the fuel pressure has increased up to 450 – 600 kPa (4.5 – 6.0 kg/cm<sup>2</sup>, 64 – 85 psi).

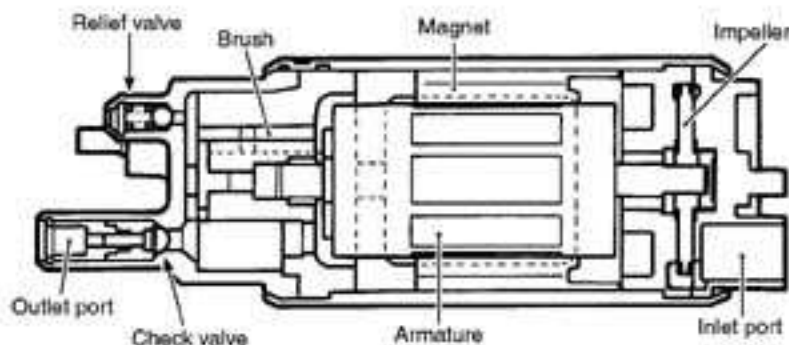

When the impeller is driven by the motor, pressure differential occurs between the front part and the rear part of the blade groove as viewed in angular direction due to fluid friction. This process continuously takes place causing fuel pressure to be built up. The pressurized fuel is then let out from the pump chamber and discharged through the motor section and the check valve.

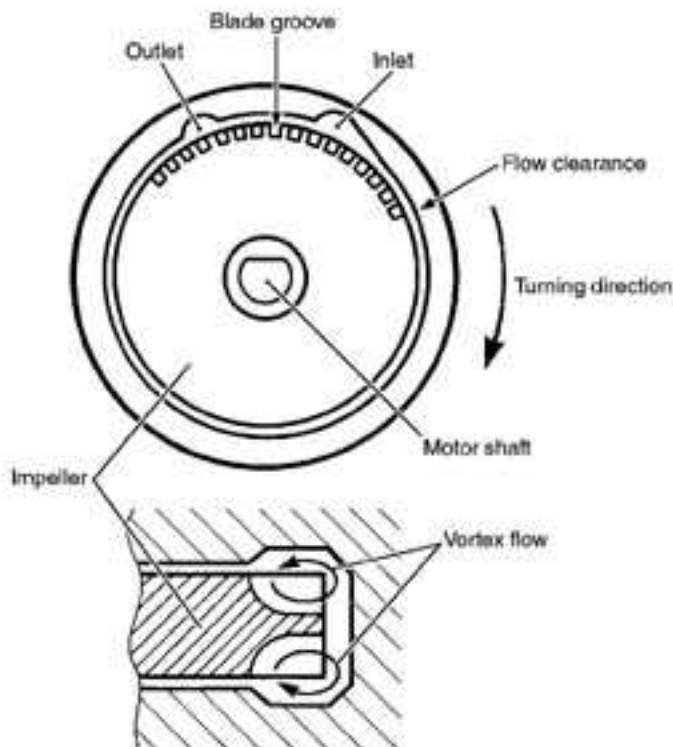

## FUEL PRESSURE REGULATOR

The fuel pressure regulator consists of the spring and valve. It keeps absolute fuel pressure of 300 kPa (3.0 kgf/cm<sup>2</sup>, 43 psi) applied to the injector at all times.

When the fuel pressure rises more than 300 kPa (3.0 kgf/cm<sup>2</sup>, 43 psi), the fuel pushes the valve in the regulator open and excess fuel returns to the fuel tank.

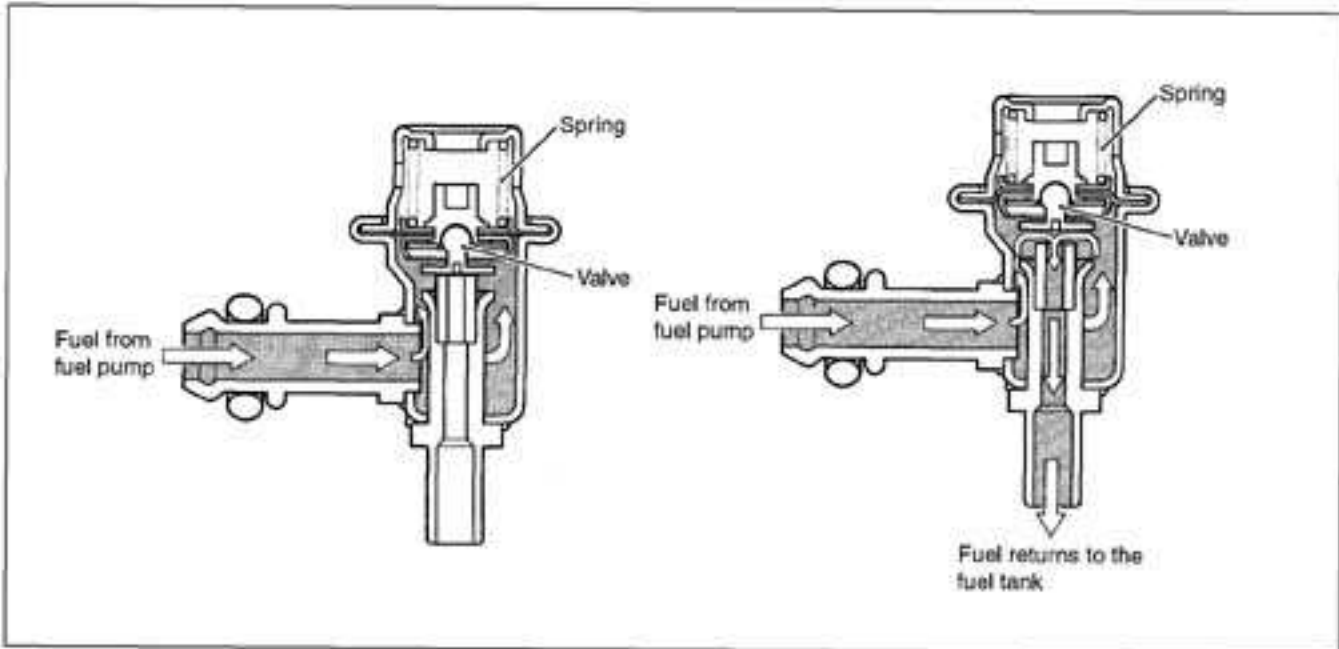

## FUEL INJECTOR

The fuel injector consists of the solenoid coil, plunger, needle valve and filter.

It is an electromagnetic type injection nozzle which injects fuel in the throttle body according to the signal from the ECM.

When the solenoid coil of the injector is energized by the ECM, it becomes an electromagnet and attracts the plunger. At the same time, the needle valve incorporated with the plunger opens and the injector which is under the fuel pressure injects fuel in conic dispersion. As the lift stroke of the needle valve of the injector is set constant, the volume of the fuel injected at one time is determined by the length of time during which the solenoid coil is energized (injection time).

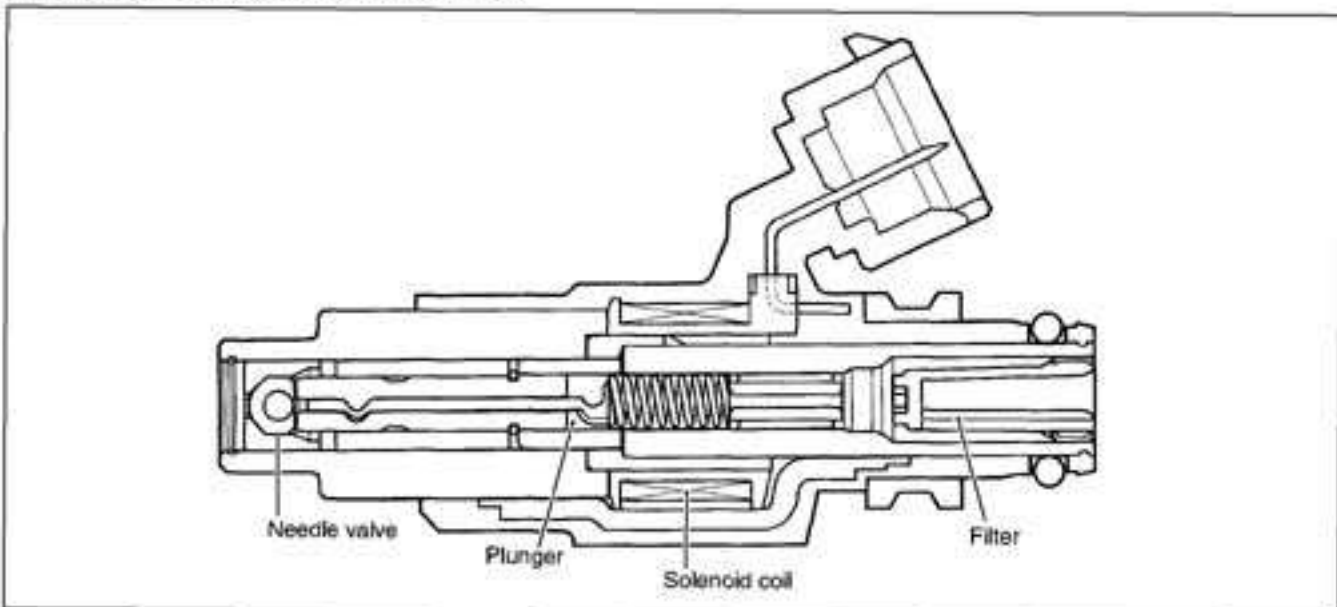

## FUEL PUMP CONTROL SYSTEM

When the ignition switch is turned on, current from the battery flows to the fuel pump motor through the side-stand relay and the fuel pump relay causing the motor to turn.

Since the ECM has a timer function, the fuel pump motor stops turning in three seconds after the switch has been turned on.

Thereafter, when the crankshaft is turned by the starter motor or the engine has been started, the engine revolving signal is input to the ECM. Then, current flows to the fuel pump motor from the battery through the side-stand relay and the fuel pump relay so that the pump continues to function.

A tip over sensor is provided in the fuel pump control circuit. By this provision, anytime the motorcycle tips over, the tip over sensor sends a signal to the ECM to turn off power to the fuel pump relay, causing the fuel pump motor to stop. At the same time, current to the fuel injectors as well as the ignition coil is interrupted, which then stops the engine.

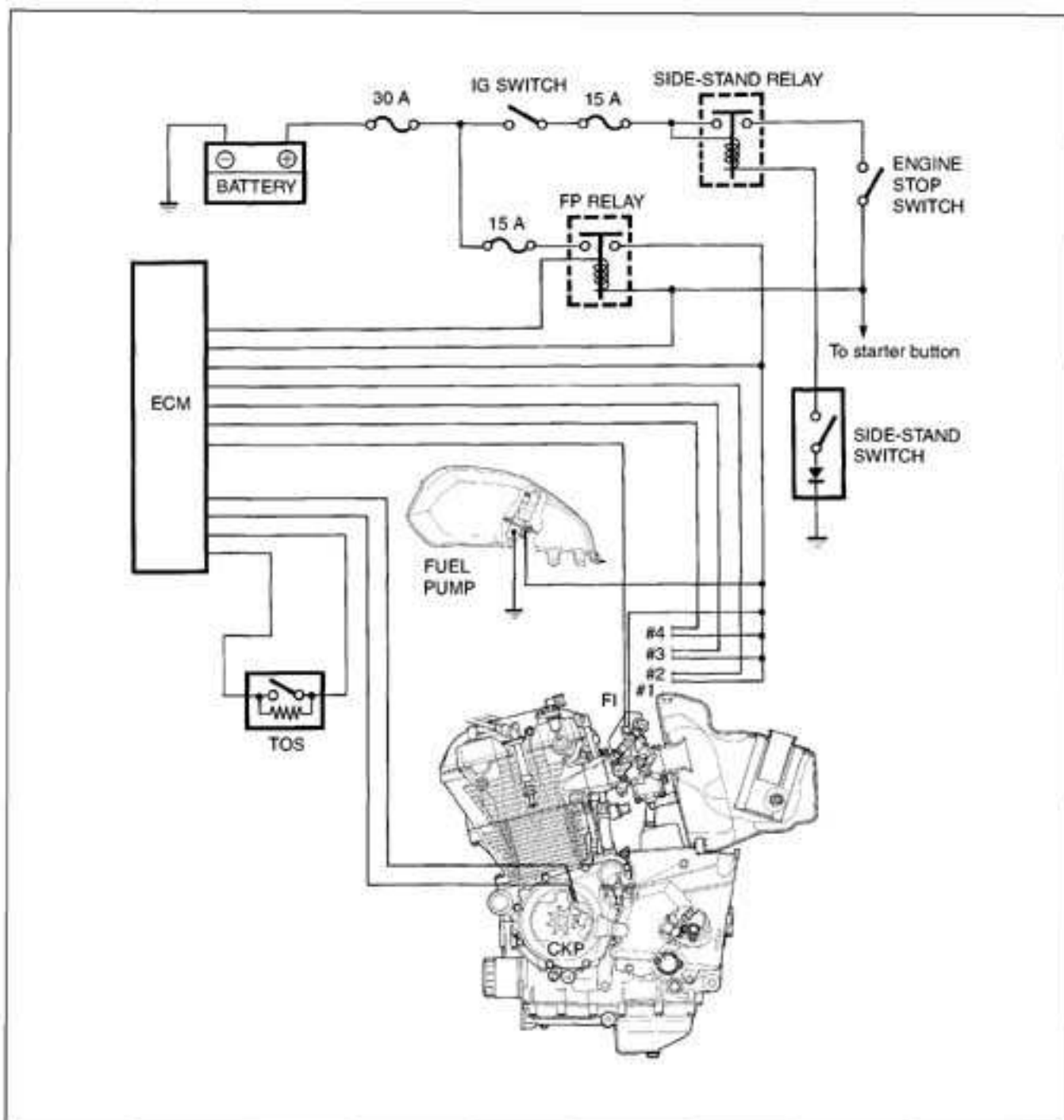

## ECM (FI CONTROL UNIT)

The ECM is located under the seat.

The ECM consists of CPU (Central Processing Unit), memory (ROM) and I/O (Input/Output) sections. The signal from each sensor is sent to the input section and then sent to CPU. On the basis of signal information received, CPU calculates the volume of fuel necessary for injection using maps programmed for varying engine conditions. Then, the operation signal of the fuel injection is sent from the output section to the fuel injector.

The eight kinds of independent program maps are programmed in the ROM.

These eight kinds of maps are designed to compensate for differences of the intake/exhaust systems and cooling performance.

**LIGHT LOAD:** When the engine is running in a light load, the fuel injected volume (time) is determined the basis of the intake air pressure and engine speed.

**HEAVY LOAD:** When the engine is running in a heavy load, the fuel injected volume (time) is determined the basis of the throttle valve opening and engine speed.



## INJECTION TIMING

The system employs a sequential, four-cylinder independent injection type, using the crankshaft position sensor (signal generator) to determine the piston position (injection timing and ignition timing) and the camshaft position sensor to identify the cylinder during operation, and these information are sent to the ECM. This makes it possible to inject the optimum volume of fuel in the best timing for the engine operating conditions. When the crankshaft begins to turn at the time of starting, the ECM sends the signals to the four injectors, #1, #2, #3 and #4 to have them inject fuel simultaneously. From the second turn onward, the sequential four-cylinder independent injection occurs as explained above.

## SENSORS

### INTAKE AIR PRESSURE SENSOR (IAP SENSOR)

The intake air pressure sensor is located at the upper frame between the tubes and its vacuum hose is connected to the throttle body.

The sensor detects the intake air pressure, which is then converted into voltage signal and sent to the ECM.

The basic fuel injection time (volume) is determined according to the voltage signal (output voltage).

The voltage signal increases when the intake air pressure is high.

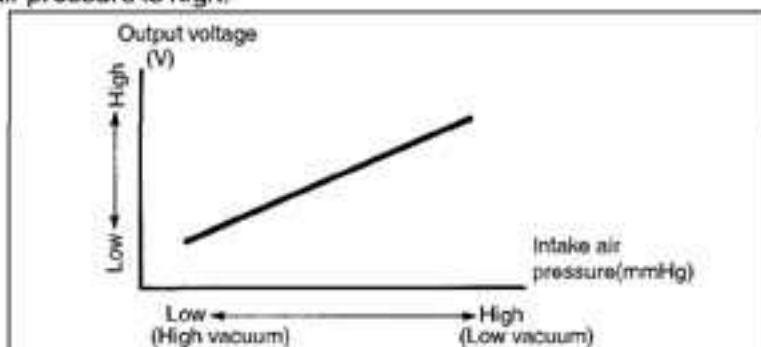

### THROTTLE POSITION SENSOR (TP SENSOR)

The throttle position sensor is installed on the No.1 throttle body. The throttle position sensor is a kind of variable resistor which detects the throttle opening angle.

The battery voltage in the sensor is changed to the throttle position voltage which is then sent to the ECM.

The basic fuel injection time (volume) is determined according to the voltage signal (output voltage).

The voltage signal increases as the throttle is opened wider.

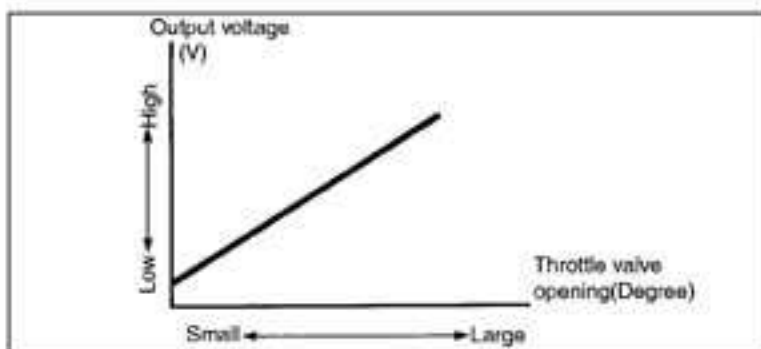



**CRANKSHAFT POSITION SENSOR (CKP SENSOR)**

The signal rotor is mounted on the right end of the crankshaft, and the crankshaft position sensor (Pick-up coil) is installed on the right side of the crankcase.

The sensor generates the pick-up signal to be supplied to the ECM.

The ECM calculates and decides both the fuel injection timing and ignition timing.

The injection volume increases when the engine rpm is high.

**CAMSHAFT POSITION SENSOR (CMP SENSOR)**

The signal rotor is installed on the intake camshaft, and the camshaft position sensor (Pick-up coil) is installed on the cylinder head cover.

The sensor generates the pick-up signal to be supplied to the ECM.

The ECM calculates and decides the cylinder identity and sequential injection timing.

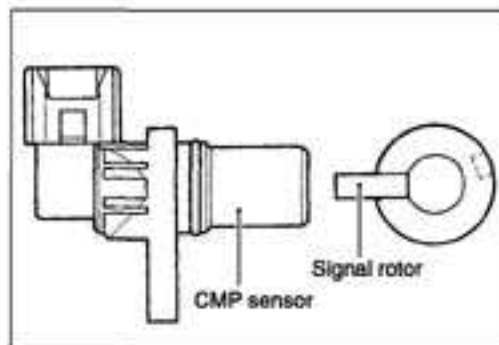
**INTAKE AIR TEMPERATURE SENSOR (IAT SENSOR)**

The intake air temperature sensor is installed at the right side of the air cleaner box.

The sensor detects the intake air temperature in thermistor resistance value. With this resistance value converted to voltage signal, the signal is sent to the ECM. The injection volume increases as intake air temperature decreases.

The thermistor resistance value increases when the intake air temperature is low, and decreases when the intake air temperature is high.

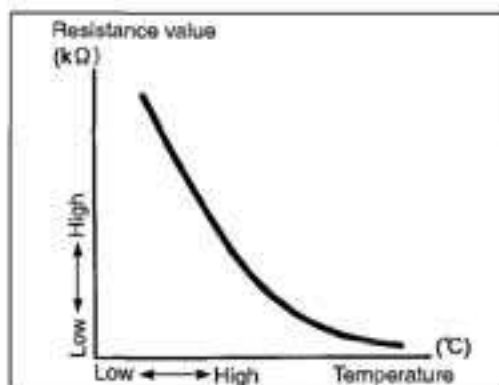
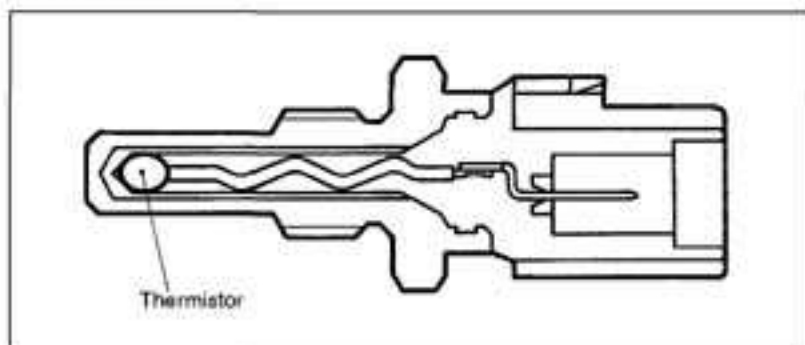

### ENGINE OIL TEMPERATURE SENSOR (EOT SENSOR)

The engine oil temperature sensor is installed at the upper crankcase.

The sensor detects the engine oil temperature in thermistor resistance value, which is then converted to voltage signal and sent to the ECM. The injection volume increases as oil temperature decreases.

The thermistor resistance value increases when the engine oil temperature is low, and decreases when the engine oil temperature is high.

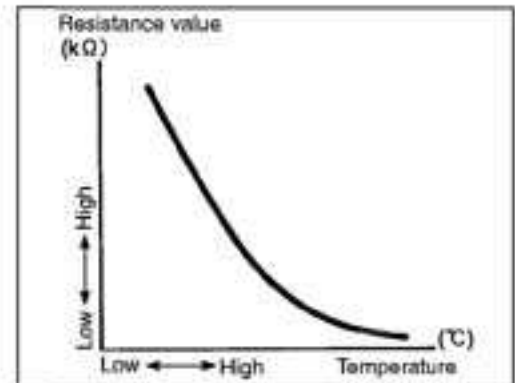
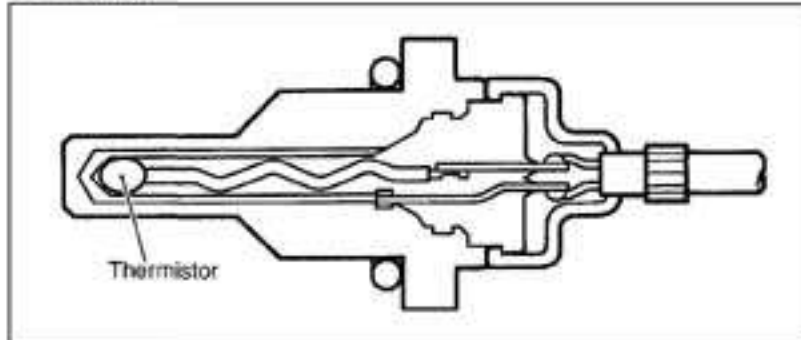

### ATMOSPHERIC PRESSURE SENSOR (AP SENSOR)

The atmospheric pressure sensor is located at the right side of the air cleaner box.

The sensor detects the atmospheric pressure. The detected pressure is converted into voltage signal and sent to the ECM.

The injection time (volume) is controlled according to the voltage signal (output voltage).

The voltage signal increases as the atmospheric pressure rises.

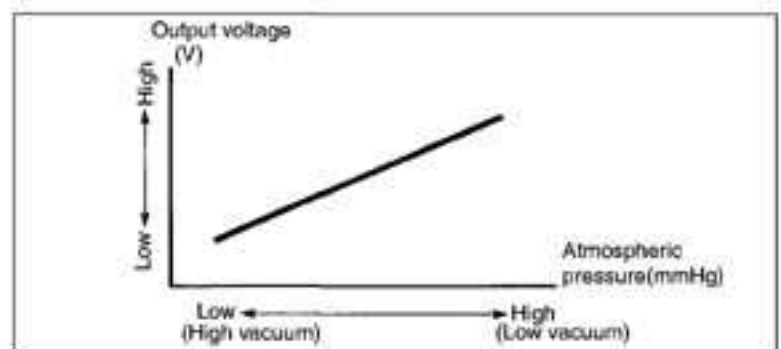

**TIP OVER SENSOR (TO SENSOR)**

The tip over sensor is located in ahead of the battery holder. The sensor detects the leaning of the motorcycle. When it leans more than  $43^{\circ}$ , the mechanical switch turns ON and a signal is sent to the ECM. At the same time, this signal cuts OFF current supply to the fuel pump, fuel injectors and ignition coils.

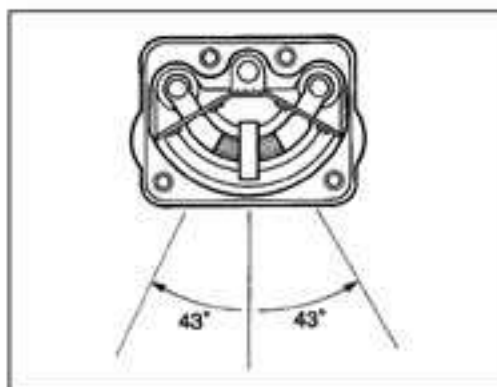
**SECONDARY THROTTLE POSITION SENSOR (STP SENSOR)**

The secondary throttle position sensor is installed on the No.4 throttle body.

The secondary throttle position sensor is a kind of variable resistor which detects the secondary throttle opening angle.

The STP sensor detects the STV actuator movement by the voltage signal which is then sent to the ECM.

The ECM determines the ST valve angle based on the operation map.

The voltage signal increases as the secondary throttle is opened wider.

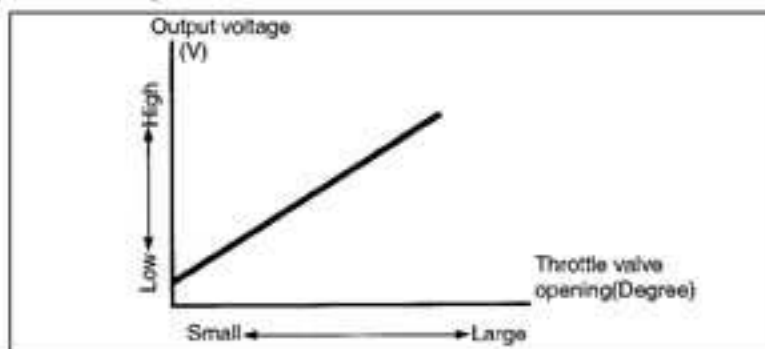

## FI SYSTEM PARTS LOCATION

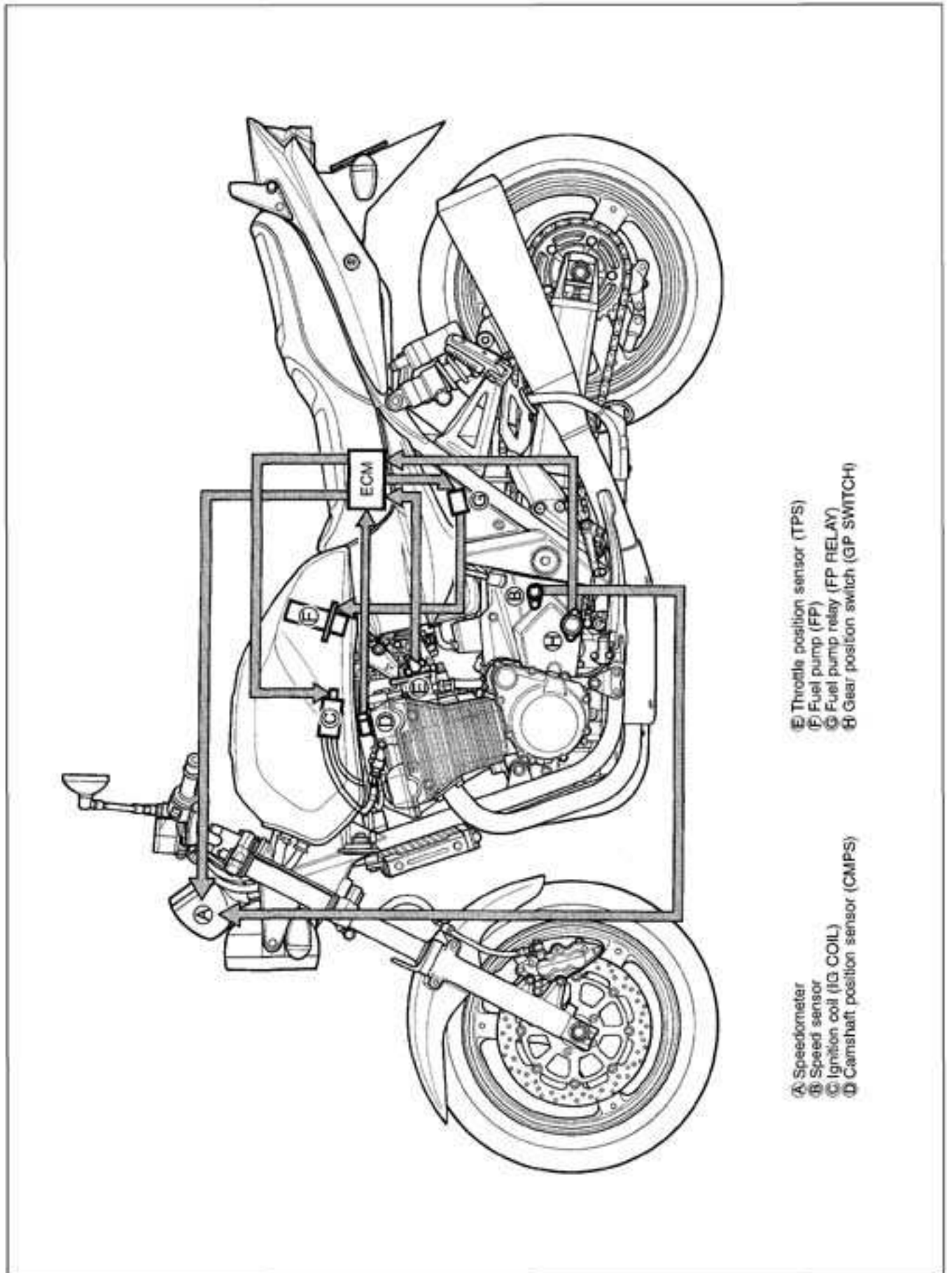

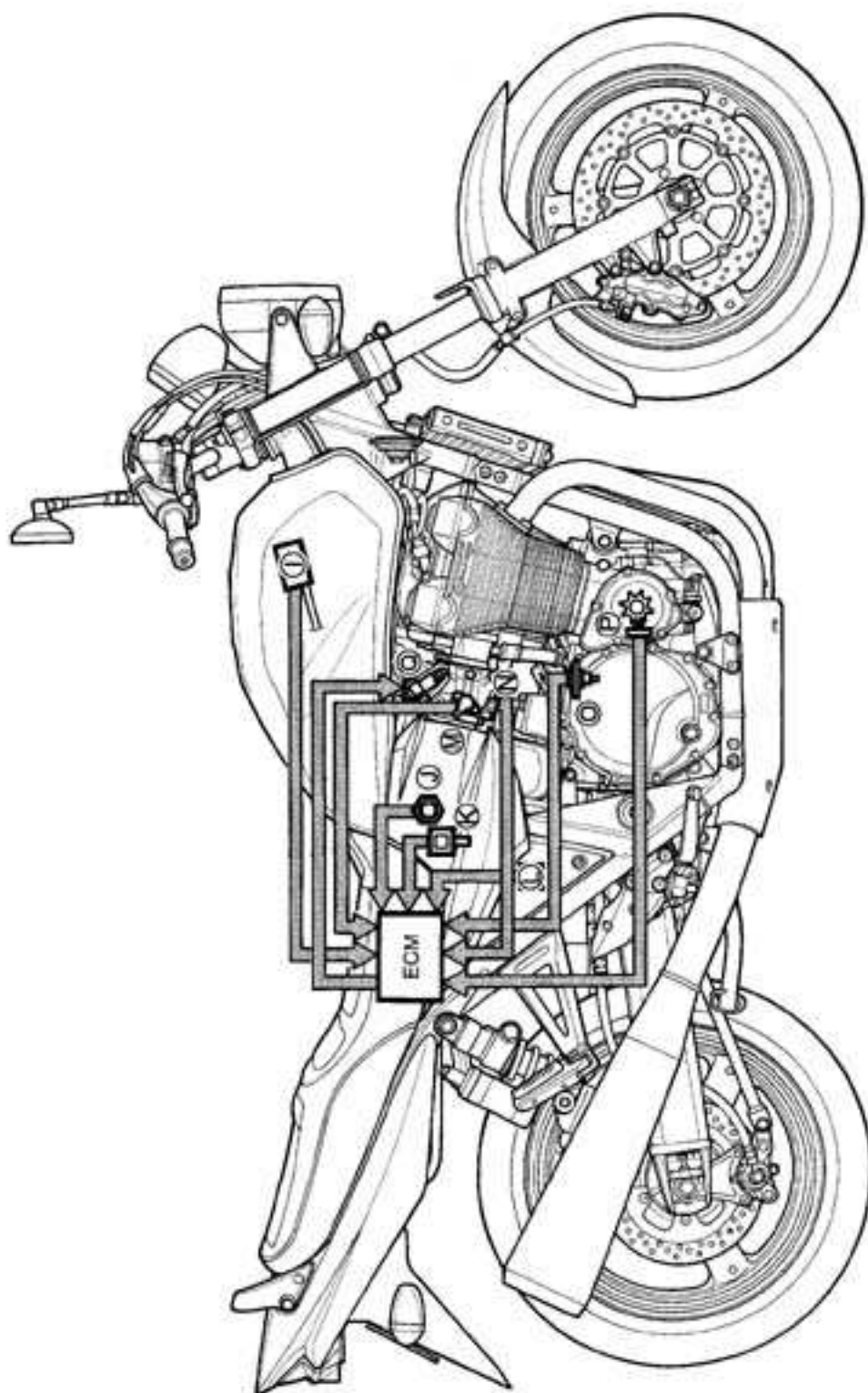

- ① Intake air pressure sensor (IAPS)
- ② Intake air temperature sensor (IATS)
- ③ Atmospheric pressure sensor (APS)
- ④ Tip over sensor (TOS)

- ⑤ Secondary throttle position sensor (STPS)
- ⑥ Secondary throttle valve actuator (STVA)
- ⑦ Engine oil temperature sensor (EOTS)
- ⑧ Crankshaft position sensor (CKPS)
- ⑨ Fuel injector (FI)

# FI SYSTEM DIAGRAM

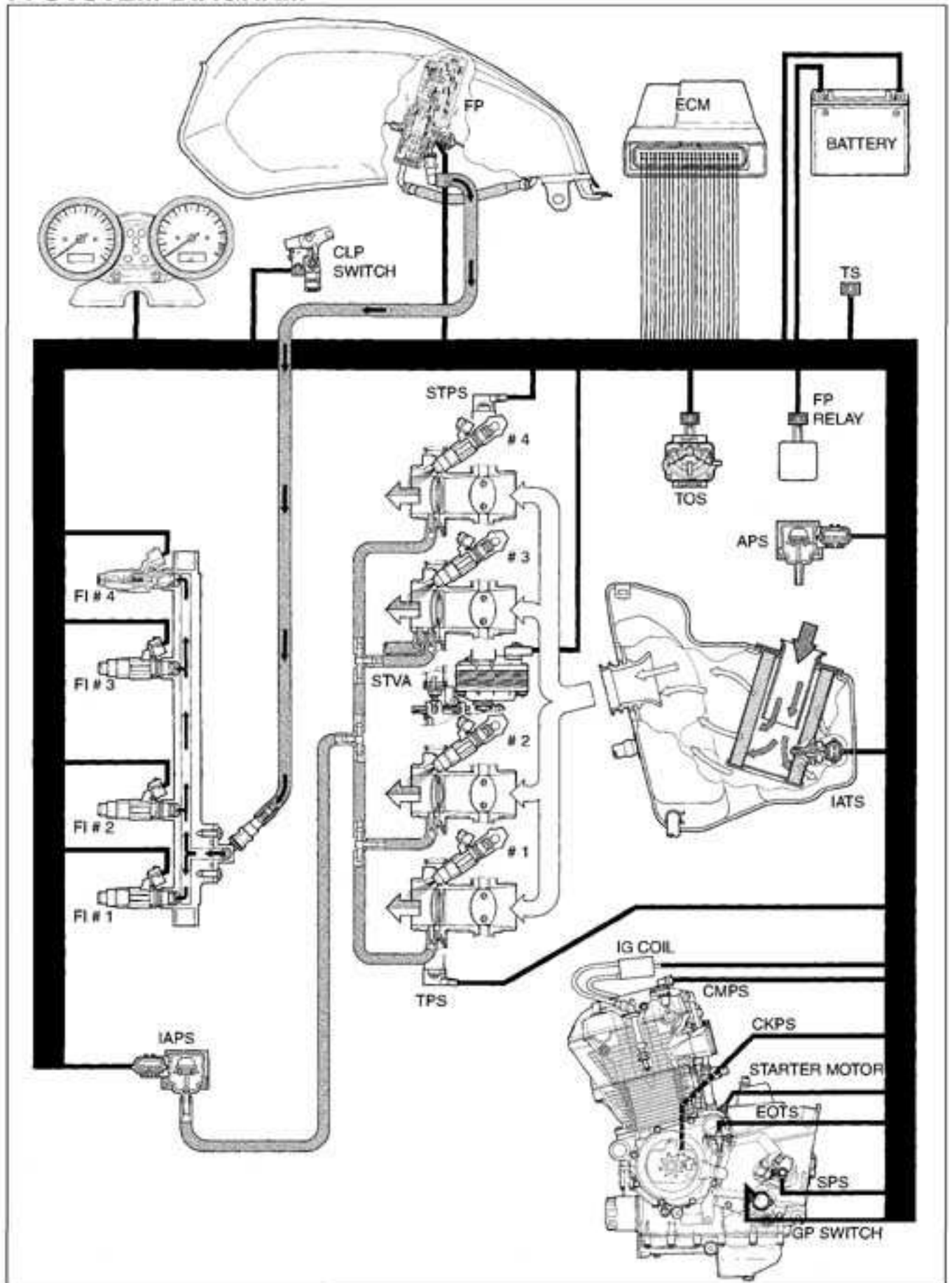



# FI SYSTEM WIRING DIAGRAM

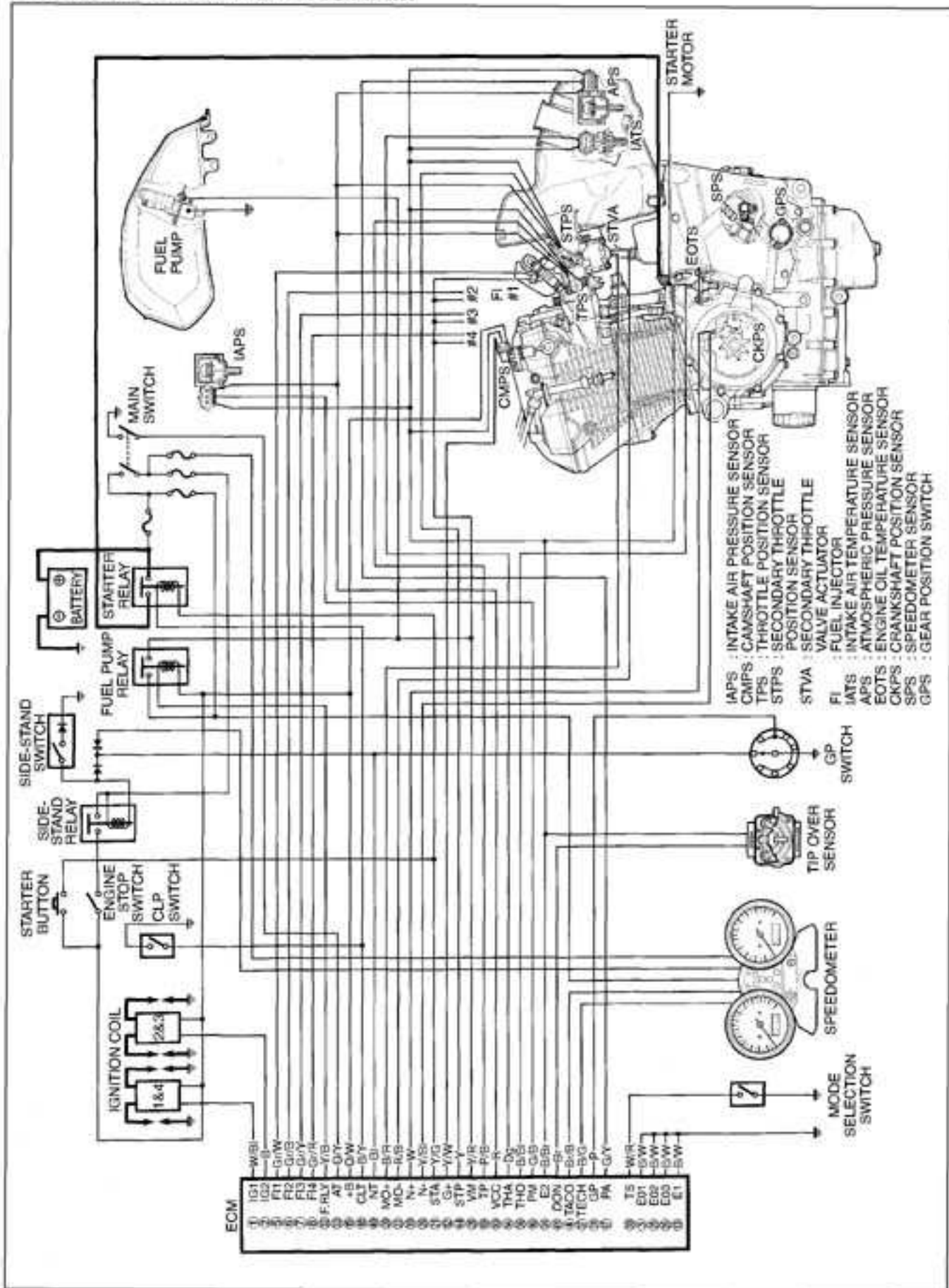



## SELF-DIAGNOSIS FUNCTION

The self-diagnosis function is incorporated in the ECM. The function has two modes, "User mode" and "Dealer mode". The user can only be notified by the LCD (DISPLAY) panel and LED (FI light). To check the function of the individual FI system devices, the dealer mode is prepared. In this check, the special tool is necessary to read the code of the malfunction items.

### USER MODE

MALFUNCTION	LCD (DISPLAY) INDICATION	FI LIGHT INDICATION	INDICATION MODE
"NO"	Odometer	—	—
"YES"	Odometer and "FI" letters *1	FI light turns ON.	Each 2 sec. Odometer or "FI" is indicated.
Engine can start			
Engine can not start	"FI" letter *2	FI light turns ON and blinks.	"FI" is indicated continuously.

\*1

When one of the signals is not received by ECM, the fail-safe circuit works and injection is not stopped. In this case, "FI" and odometer are indicated in the LCD panel and motorcycle can run.

\*2

The injection signal is stopped, when the crankshaft position sensor signal, tip over sensor signal, #1/#4 and #2/#3 ignition signals, #1/#2, #1/#3, #1/#4, #2/#3, #2/#4 and #3/#4 injector signals, fuel pump relay signal or ignition switch signal is not sent to ECM. In this case, "FI" is indicated in the LCD panel. Motorcycle does not run.

"CHEC": The LCD panel indicates "CHEC" when no communication signal from the ECM is received for 3 seconds.

For Example:

The ignition switch is turned ON, and the engine stop switch is turned OFF. In this case, the speedometer does not receive any signal from the ECM, and the panel indicates "CHEC".

If CHEC is indicated, the LCD does not indicate the trouble code. It is necessary to check the wiring harness between ECM and speedometer couplers.

The possible cause of this indication is as follows;

Engine stop switch is in OFF position. Side-stand/ignition inter-lock system is not working. Ignition fuse is burnt.

## DEALER MODE

The defective function is memorized in the computer. Use the special tool's coupler to connect to the dealer mode coupler. The memorized malfunction code is displayed on LCD (DISPLAY) panel. Malfunction means that the ECM does not receive signal from the devices. These affected devices are indicated in the code form.

 09930-82710: Mode select switch

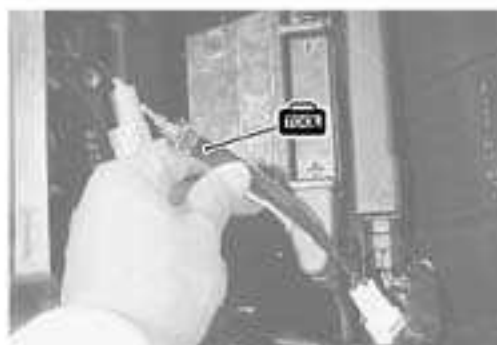

### CAUTION

Before checking the malfunction code, do not disconnect the ECM lead wire couplers. If the couplers from the ECM are disconnected, the malfunction code memory is erased and the malfunction code can not be checked.

MALFUNCTION	LCD (DISPLAY) INDICATION	FI LIGHT INDICATION	INDICATION MODE
"NO"	c00	FI light turns OFF.	—
"YES"	c** code is indicated from small numeral to large one.		For each 2 sec., code is indicated.

CODE	MALFUNCTION PART	REMARKS
c00	None	No defective part
c11	Camshaft position sensor (CMPS)	
c12	Crankshaft position sensor (CKPS)	Pick-up coil signal, signal generator
c13	Intake air pressure sensor (IAPS)	
c14	Throttle position sensor (TPS)	
c15	Engine oil temp. sensor (EOTS)	
c21	Intake air temp. sensor (IATS)	
c22	Atmospheric pressure sensor (APS)	
c23	Tip over sensor (TOS)	
c24	Ignition signal #1, #4 (IG coil #1, #4)	For #1 & 4 cylinders
c25	Ignition signal #2, #3 (IG coil #2, #3)	For #2 & 3 cylinders
c28	Secondary throttle valve actuator (STVA)	*3
c29	Secondary throttle position sensor (STPS)	
c31	Gear position signal (GP switch)	
c32	Injector signal #1 (FI #1)	For #1 cylinder
c33	Injector signal #2 (FI #2)	For #2 cylinder
c34	Injector signal #3 (FI #3)	For #3 cylinder
c35	Injector signal #4 (FI #4)	For #4 cylinder
c41	Fuel pump control system (FP control system)	Fuel pump, Fuel pump relay
c42	Ignition switch signal (IG switch signal)	Anti-theft

In the LCD (DISPLAY) panel, the malfunction code is indicated from small code to large code.

\*3

When the secondary throttle valve actuator and secondary throttle position sensor signals are not sent to ECM. In this case, c29 is indicated.

## FAIL-SAFE FUNCTION

FI system is provided with fail-safe function to allow the engine to start and the motorcycle to run in a minimum performance necessary even under malfunction condition.

ITEM	FAIL-SAFE MODE	STARTING ABILITY	RUNNING ABILITY
Camshaft position sensor	ECM determines cylinder as number before occurrence of such a failure.	"YES"	"YES"
Intake air pressure sensor	Intake air pressure is fixed to 760 mmHg.	"YES"	"YES"
Throttle position sensor	The throttle opening is fixed to full open position. Ignition timing is also fixed.	"YES"	"YES"
Engine oil temperature sensor	Engine oil temperature value is fixed to 80°C.	"YES"	"YES"
Intake air temperature sensor	Intake air temperature value is fixed to 40°C.	"YES"	"YES"
Atmospheric pressure sensor	Atmospheric pressure is fixed to 760 mmHg.	"YES"	"YES"
Ignition signal	#1, #4 #1/#4 Ignition-off	"YES"	"YES"
	#2, #3 #2/#3 Ignition-off	"YES"	"YES"
Injection signal	#1 #1 Fuel-cut	"YES"	"YES"
	#2 #2 Fuel-cut	"YES"	"YES"
	#3 #3 Fuel-cut	"YES"	"YES"
	#4 #4 Fuel-cut	"YES"	"YES"
Secondary throttle valve actuator	Secondary throttle valve is fixed to half open position.	"YES"	"YES"
Secondary throttle position sensor	Secondary throttle valve is fixed to half open position.	"YES"	"YES"
Gear position signal	Gear position signal is fixed to 6th gear.	"YES"	"YES"

"Yes" means that the engine can start and can run even if the above signal is not received from each sensor. But, the engine running condition is not complete, providing only emergency help (by fail-safe circuit). In this case, it is necessary to bring the motorcycle to the workshop for complete repair.

Only for injector signal:

Two injector signals are not received by ECM ("FI" is indicated in the LCD panel), but the fail-safe circuit works and injection is not stopped.

## FI SYSTEM TROUBLESHOOTING

### CUSTOMER COMPLAINT ANALYSIS

Record details of the problem (failure, complaint) and how it occurred as described by the customer. For this purpose, use of such an inspection form will facilitate collecting information to the point required for proper analysis and diagnosis.

#### EXAMPLE: CUSTOMER PROBLEM INSPECTION FORM

User name:	Model:	VIN:	
Date of issue:	Date Reg.	Date of problem:	Mileage:
Malfunction indicator lamp condition (LED)	<input type="checkbox"/> Always ON <input type="checkbox"/> Sometimes ON <input type="checkbox"/> Always OFF <input type="checkbox"/> Good condition		
Malfunction display/code (LCD)	User mode: <input type="checkbox"/> No display <input type="checkbox"/> Malfunction display (            )		
	Dealer mode: <input type="checkbox"/> No code <input type="checkbox"/> Malfunction code (            )		
<b>PROBLEM SYMPTOMS</b>			
<input type="checkbox"/> <b>Difficult Starting</b> <input type="checkbox"/> No cranking <input type="checkbox"/> No initial combustion <input type="checkbox"/> No combustion <input type="checkbox"/> Poor starting at <input type="checkbox"/> cold <input type="checkbox"/> warm <input type="checkbox"/> always) <input type="checkbox"/> Other _____		<input type="checkbox"/> <b>Poor Driveability</b> <input type="checkbox"/> Hesitation on acceleration <input type="checkbox"/> Back fire/ <input type="checkbox"/> After fire <input type="checkbox"/> Lack of power <input type="checkbox"/> Surging <input type="checkbox"/> Abnormal knocking <input type="checkbox"/> Other _____	
<input type="checkbox"/> <b>Poor Idling</b> <input type="checkbox"/> Poor fast idle <input type="checkbox"/> Abnormal idling speed <input type="checkbox"/> High <input type="checkbox"/> Low) (        r/min) <input type="checkbox"/> Unstable <input type="checkbox"/> Hunting (        r/min. to        r/min) <input type="checkbox"/> Other _____		<input type="checkbox"/> <b>Engine Stall when</b> <input type="checkbox"/> Immediately after start <input type="checkbox"/> Throttle valve is opened <input type="checkbox"/> Throttle valve is closed <input type="checkbox"/> Load is applied <input type="checkbox"/> Other	
<input type="checkbox"/> OTHERS:			
<b>MOTORCYCLE/ENVIRONMENTAL CONDITION WHEN PROBLEM OCCURS</b>			
<b>Environmental condition</b>			
Weather	<input type="checkbox"/> Fair <input type="checkbox"/> Cloudy <input type="checkbox"/> Rain <input type="checkbox"/> Snow <input type="checkbox"/> Always <input type="checkbox"/> Other		
Temperature	<input type="checkbox"/> Hot <input type="checkbox"/> Warm <input type="checkbox"/> Cool <input type="checkbox"/> Cold (        °F/        °C) <input type="checkbox"/> Always		
Frequency	<input type="checkbox"/> Always <input type="checkbox"/> Sometimes (        times/        day, month) <input type="checkbox"/> Only once		
	<input type="checkbox"/> Under certain condition		
Road	<input type="checkbox"/> Urban <input type="checkbox"/> Suburb <input type="checkbox"/> Highway <input type="checkbox"/> Mountainous ( <input type="checkbox"/> Uphill <input type="checkbox"/> Downhill)		
	<input type="checkbox"/> Tarmacadam <input type="checkbox"/> Gravel <input type="checkbox"/> Other		
<b>Motorcycle condition</b>			
Engine condition	<input type="checkbox"/> Cold <input type="checkbox"/> Warming up phase <input type="checkbox"/> Warmed up <input type="checkbox"/> Always <input type="checkbox"/> Other at starting		
	<input type="checkbox"/> Immediately after start <input type="checkbox"/> Racing without load <input type="checkbox"/> Engine speed (        r/min)		
Motorcycle condition	During driving: <input type="checkbox"/> Constant speed <input type="checkbox"/> Accelerating <input type="checkbox"/> Decelerating		
	<input type="checkbox"/> Right hand corner <input type="checkbox"/> Left hand corner <input type="checkbox"/> When shifting (Gear position        )		
	<input type="checkbox"/> At stop <input type="checkbox"/> Motorcycle speed when problem occurs (        km/h,        Mile/h)		
	<input type="checkbox"/> Other _____		

#### NOTE:

The above form is a standard sample. It should be modified according to conditions characteristic of each market.

## SELF-DIAGNOSTIC PROCEDURES

- Don't disconnect couplers from ECM, battery cable from battery, ECM ground wire harness from engine or main fuse before confirming malfunction code (self-diagnostic trouble code) stored in memory. Such disconnection will erase memorized information in ECM memory.
- Malfunction code stored in ECM memory can be checked by the special tool.
- Before checking malfunction code, read SELF-DIAGNOSIS FUNCTION "USER MODE and DEALER MODE" (☞ 4-23 and -24) carefully to have good understanding as to what functions are available and how to use it.
- Be sure to read "PRECAUTIONS for Electrical Circuit Service" (☞ 4-4) before inspection and observe what is written there.
- Remove the seat and tray.
- Connect the special tool to the dealer mode coupler (A) at the wiring harness, and start the engine or crank the engine for more than 4 seconds.
- Turn the special tool's switch ON and check the malfunction code to determine the malfunction part.

 09930-82710: Mode select switch

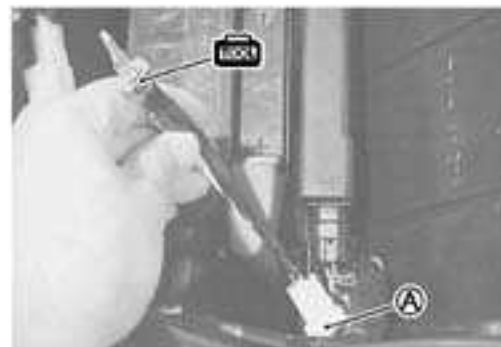
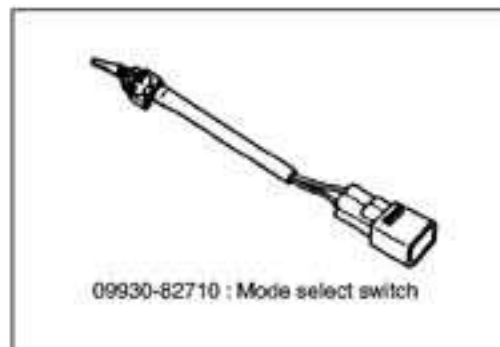

## SELF-DIAGNOSIS RESET PROCEDURE

- After repairing the trouble, turn OFF the ignition switch and turn ON again.  
If the malfunction code indicates (c00), the malfunction is cleared.
- Disconnect the special tool from the dealer mode coupler.





## MALFUNCTION CODE AND DEFECTIVE CONDITION

MALFUNCTION CODE	DETECTED ITEM	DETECTED FAILURE CONDITION
		CHECK FOR
c00	NO FAULT	—————
c11	Camshaft position sensor	The signal does not reach ECM for more than 4 sec. after receiving the starter signal.
		The camshaft position sensor wiring and mechanical parts. (Camshaft position sensor, intake cam pin, wiring/coupler connection)
c12	Crankshaft position sensor	The signal does not reach ECM for more than 3 sec. after receiving the starter signal.
		The crankshaft position sensor wiring and mechanical parts. (Crankshaft position sensor, wiring/coupler connection)
c13	Intake air pressure sensor	The sensor should produce following voltage. ( $0.20\text{ V} \leq \text{sensor voltage} < 4.80\text{ V}$ ) Without the above range, c13 is indicated.
		Intake air pressure sensor, wiring/coupler connection.
c14	Throttle position sensor	The sensor should produce following voltage. ( $0.20\text{ V} \leq \text{sensor voltage} < 4.80\text{ V}$ ) Without the above range, c14 is indicated.
		Throttle position sensor, wiring/coupler connection.
c15	Engine oil temperature sensor	The sensor voltage should be the following. ( $0.26\text{ V} \leq \text{sensor voltage} < 4.77\text{ V}$ ) Without the above range, c15 is indicated.
		Engine oil temperature sensor, wiring/coupler connection.
c21	Intake air temperature sensor	The sensor voltage should be the following. ( $0.17\text{ V} \leq \text{sensor voltage} < 4.60\text{ V}$ ) Without the above range, c21 is indicated.
		Intake air temperature sensor, wiring/coupler connection.
c22	Atmospheric pressure sensor	The sensor voltage should be the following. ( $0.20\text{ V} \leq \text{sensor voltage} < 4.80\text{ V}$ ) Without the above range, c22 is indicated.
		Atm. pressure sensor, wiring/coupler connection.
c23	Tip over sensor	The sensor voltage should be less than the following for more than 4 sec. after ignition switch turns ON. (sensor voltage $< 3.90\text{ V}$ ) Without the above value, c23 is indicated.
		Tip over sensor, wiring/coupler connection.
c24 or c25	Ignition signal	Crankshaft position sensor (pick-up coil) signal is produced but signal from ignition coil is interrupted continuous by two times or more. In this case, the code c24 or c25 is indicated.
		Ignition coil, wiring/coupler connection, power supply from the battery.

c28	Secondary throttle valve actuator	When no actuator control signal is supplied from the ECM or communication signal does not reach ECM or operation voltage does not reach STVA motor, c28 is indicated. STVA can not operate. ----- STVA lead wire/coupler.
c29	Secondary throttle position sensor	The sensor should produce following voltage. ( $0.20\text{ V} \leq \text{sensor voltage} < 4.80\text{ V}$ ) Without the above range, c29 is indicated. ----- Secondary throttle position sensor, wiring/coupler connection.
c31	Gear position signal	Gear position signal voltage should be higher than the following for more than 4 seconds. (Gear position sensor voltage $> 0.60\text{ V}$ ) Without the above value, c31 is indicated. ----- Gear position sensor, wiring/coupler connection. Gearshift cam etc.
c32, c33, c34 or c35	Fuel injector signal	When fuel injection signal stops, the c32, c33, c34 or c35 is indicated. ----- Injector, wiring/coupler connection, power supply to the injector.
c41	Fuel pump relay signal	When no signal is supplied from fuel pump relay, c41 is indicated. ----- Fuel pump relay, connecting lead, power source to fuel pump relay.
c42	Ignition switch signal	Ignition switch signal is not input in the ECM. ----- Ignition switch, lead wire/coupler.

## "C11" CMP SENSOR CIRCUIT MALFUNCTION

DETECTED CONDITION	POSSIBLE CAUSE
No CMP sensor signal for 4 seconds at engine cranking.	<ul style="list-style-type: none"> <li>• Metal particles or foreign material being attached on the CMP sensor and rotor tip.</li> <li>• CMP sensor circuit open or short.</li> <li>• CMP sensor malfunction.</li> <li>• ECM malfunction.</li> </ul>

### INSPECTION

- Lift and support the fuel tank with a proper stay. (☞ 4-48)

1 Turn the ignition switch OFF.  
Check the CMP sensor coupler for loose or poor contacts. If OK, then measure the CMP sensor voltage. Insert the copper wires to the CMP sensor coupler and turn the ignition switch ON, then measure the voltage.

**DATA** CMP sensor voltage: More than 3.7 V  
(⊕ Y/W - ⊖ B/Br)

**TOOL** 09900-25008: Multi circuit tester

**TESTER** Tester knob indication: Voltage (---)



No → Replace the CMP sensor with a new one.

Yes →

2 Remove the CMP sensor.  
If the metal particles or foreign material is attached on the CMP sensor and rotor tip, signal not flow correctly to the ECM. Clean the CMP sensor and rotor tip with a spray-type carburetor cleaner and blow dry with compressed air and also change the engine oil if necessary.

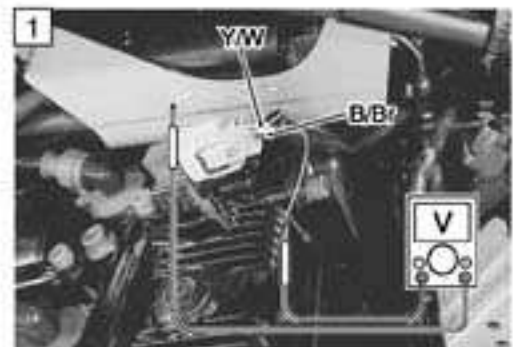

No → Loose or poor contacts on the CMP sensor coupler or ECM coupler. Replace the CMP sensor with a new one.

Yes →

O/W, Y/W or B/Br wire open or shorted to ground, or poor ② or ③ connection. (☞ 4-22)  
If wire and connection are OK, intermittent trouble or faulty ECM. Recheck each terminal and wire harness for open circuit and poor connection. (☞ 4-4)



→ Replace the ECM with a new one, and inspect it again.

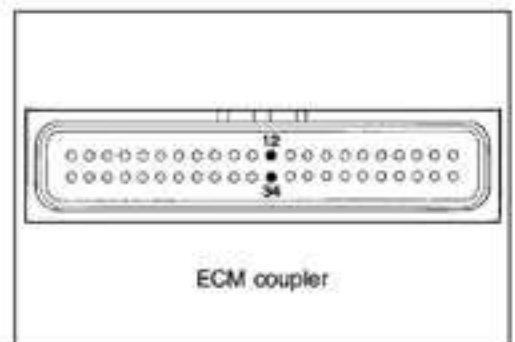

## "C12" CKP SENSOR CIRCUIT MALFUNCTION

DETECTED CONDITION	POSSIBLE CAUSE
No CKP sensor signal for 3 seconds at engine cranking.	<ul style="list-style-type: none"> <li>• Metal particles or foreign material being attached on the CKP sensor and rotor tips.</li> <li>• CKP sensor circuit open or short.</li> <li>• CKP sensor malfunction.</li> <li>• ECM malfunction.</li> </ul>

### INSPECTION

- Remove the frame side covers, left and right. (☞ 6-3)
- Lift the fuel tank little. (☞ 4-48)

**1** Turn the ignition switch OFF.  
Check the CKP sensor coupler for loose or poor contacts.  
If OK, then measure the CKP sensor resistance.  
Disconnect the CKP sensor coupler and measure the resistance.

**DATA** CKP sensor resistance: 134 – 202 Ω  
(Blue – Yellow)

If OK, then check the continuity between each terminal and ground.

**DATA** CKP sensor continuity: ∞Ω (Infinity)  
(Blue – Ground)  
(Yellow – Ground)

**TOOL** 09900-25008: Multi circuit tester

**TESTER** Tester knob indication: Resistance (Ω)

No → Replace the CKP sensor with a new one.

Yes ↓

**2** Disconnect the CKP sensor coupler.  
Crank the engine a few seconds with the starter motor, and measure the CKP sensor peak voltage at the coupler.

**DATA** CKP sensor peak voltage: More than 2.7 V  
(Blue – Yellow)

Repeat the above test procedure a few times and measure the highest peak voltage.  
If OK, then measure the CKP sensor peak voltage at the ECM terminals. (N+/N- or 26/30)

**TOOL** 09900-25008: Multi circuit tester

**TESTER** Tester knob indication: Voltage (V)

No → Loose or poor contacts on the CKP sensor coupler or ECM coupler.  
Clean the CKP sensor and rotor tips or replace the CKP sensor with a new one.

Yes ↓

Blue or Yellow wire open or shorted to ground, or poor 26 or 30 connection. (☞ 4-22)  
If wire and connection are OK, intermittent trouble or faulty ECM.  
Recheck each terminal and wire harness for open circuit and poor connection. (☞ 4-4)

→ Replace the ECM with a new one, and inspect it again.

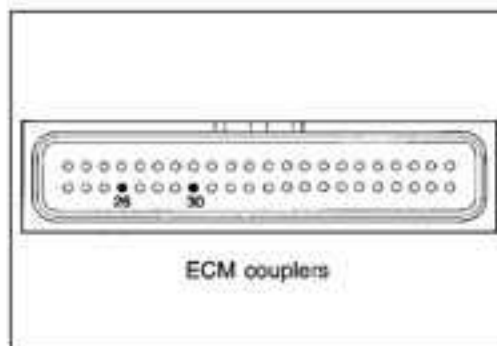
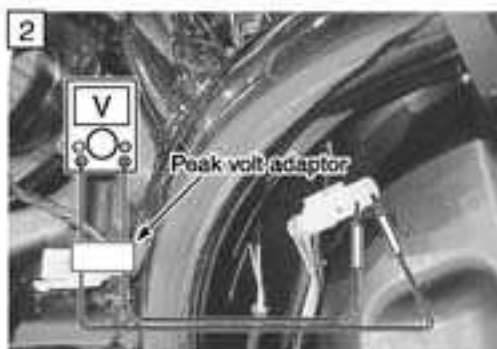

## "C13" IAP SENSOR CIRCUIT MALFUNCTION

DETECTED CONDITION	POSSIBLE CAUSE
Low pressure and low voltage. High pressure and high voltage. ( $0.20\text{ V} \leq \text{Sensor voltage} < 4.80\text{ V}$ ) ( without the above range. ) <b>NOTE:</b> <i>Note that atmospheric pressure varies depending on weather conditions as well as altitude.</i> <i>Take that into consideration when inspecting voltage.</i>	<ul style="list-style-type: none"> <li>• Clogged vacuum passage between throttle body and IAP sensor.</li> <li>• Air being drawn from vacuum passage between throttle body and IAP sensor.</li> <li>• Red wire circuit open or shorted to ground.</li> <li>• B/Br or G/B wire circuit shorted to ground.</li> <li>• IAP sensor malfunction.</li> <li>• ECM malfunction.</li> </ul>

### INSPECTION

- Lift and support the fuel tank with a proper stay. (C74-48)

- 1 Turn the ignition switch OFF.  
 Check the IAP sensor coupler for loose or poor contacts.  
 If OK, then measure the IAP sensor input voltage.  
 Disconnect the IAP sensor coupler.  
 Turn the ignition switch ON.  
 Measure the voltage at the Red wire and ground.  
 If OK, then measure the voltage at the Red wire and B/Br wire.

**DATA** IAP sensor input voltage: 4.5 – 5.5 V  
 ( ⊕Red – ⊖Ground )  
 ( ⊕Red – ⊖B/Br )

**TOOL** 09900-25008: Multi circuit tester

**TESTER** Tester knob indication: Voltage (V)

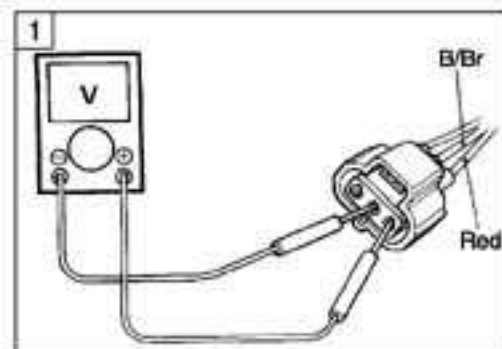
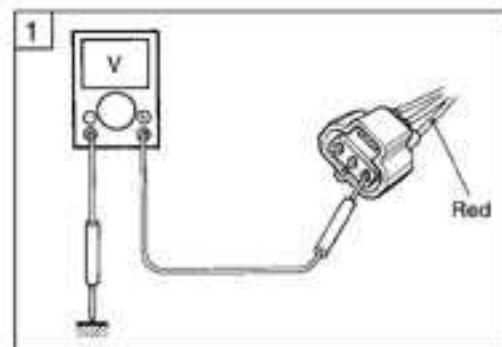

- 2 Connect the IAP sensor coupler.  
 Insert the copper wires to the lead wire coupler.  
 Start the engine at idling speed.  
 Measure the IAP sensor output voltage at the wire side coupler (between G/B and B/Br wires).

**DATA** IAP sensor output voltage: Approx. 2.5 V at idle speed (⊕G/B – ⊖B/Br)

**TOOL** 09900-25008: Multi circuit tester

**TESTER** Tester knob indication: Voltage (V)

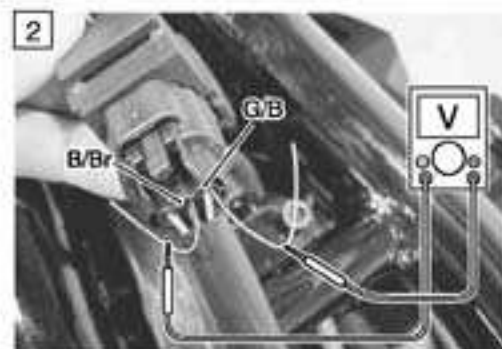

No → Loose or poor contacts on the ECM coupler.  
 Open or short circuit in the Red wire or B/Br wire.

Yes

No → Check the vacuum hose for crack or damage.  
 Open or short circuit in the G/B wire.  
 Replace the IAP sensor with a new one.

Yes



- 3 Remove the IAP sensor.  
Connect the vacuum pump gauge to the vacuum port of the IAP sensor.  
Arrange 3 new 1.5 V batteries in series (check that total voltage is 4.5 – 5.0 V) and connect  $\ominus$  terminal to the ground terminal and  $\oplus$  terminal to the Vcc terminal.  
Check the voltage between Vout and ground. Also, check if voltage reduces when vacuum is applied up to 40 cmHg by using vacuum pump gauge. (See table below.)

 09917-47010: Vacuum pump gauge  
09900-25008: Multi circuit tester

 Tester knob indication: Voltage (V)

No → If check result is not satisfactory, replace IAP sensor with a new one.  
Yes ↓

Red, G/B or B/Br wire open or shorted to ground, or poor ⑩, ⑪ or ⑫ connection. (☞ 4-22)  
If wire and connection are OK, intermittent trouble or faulty ECM. Recheck each terminal and wire harness for open circuit and poor connection. (☞ 4-4)

→ Replace the ECM with a new one, and inspect it again.

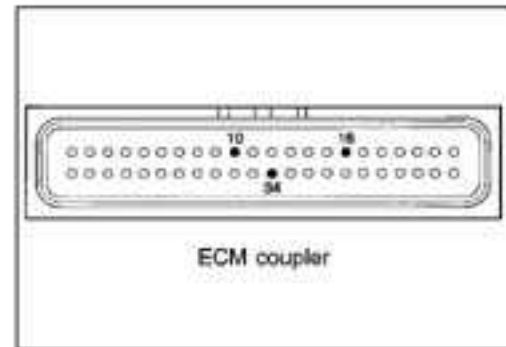
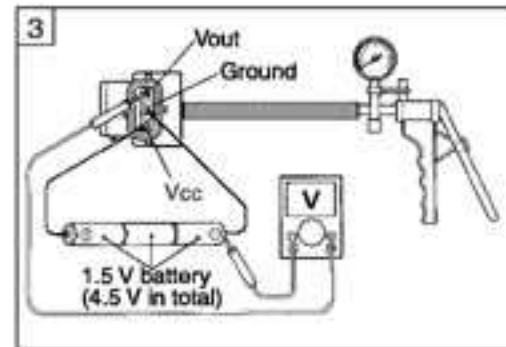

#### OUTPUT VOLTAGE (VCC VOLTAGE 4.5 – 5.0 V, AMBIENT TEMP. 20 – 30°C, 68 – 86°F)

ALTITUDE (Reference)		ATMOSPHERIC PRESSURE		OUTPUT VOLTAGE
(ft)	(m)	(mmHg)	kPa	(V)
0	0	760	100	3.4 – 4.0
2 000	610	707	94	
2 001	611	707	94	2.8 – 3.7
5 000	1 524	634	85	
5 001	1 525	634	85	2.6 – 3.4
8 000	2 438	567	76	
8 001	2 439	567	76	2.4 – 3.1
10 000	3 048	526	70	



## "C14" TP SENSOR CIRCUIT MALFUNCTION

DETECTED CONDITION	POSSIBLE CAUSE
Signal voltage low or high. Difference between actual throttle opening and opening calculated by ECM is larger than specified value. $(0.20 \text{ V} \leq \text{Sensor Voltage} < 4.80 \text{ V})$ without the above range.	<ul style="list-style-type: none"> <li>• TP sensor maladjusted.</li> <li>• TP sensor circuit open or short.</li> <li>• TP sensor malfunction.</li> <li>• ECM malfunction.</li> </ul>

### INSPECTION

- Lift and support the fuel tank with a proper stay. (☞ 4-48)

- 1 Turn the ignition switch OFF.  
 Check the TP sensor coupler for loose or poor contacts.  
 If OK, then measure the TP sensor input voltage.  
 Disconnect the TP sensor coupler (Black color).  
 Turn the ignition switch ON.  
 Measure the voltage at the Red wire and ground.  
 If OK, then measure the voltage at the Red wire and B/Br wire.

**DATA** TPS sensor input voltage: 4.5 – 5.5 V

(⊕Red – ⊖Ground)  
 (⊕Red – ⊖B/Br)

**09900-25008: Multi circuit tester**

**Tester knob indication: Voltage (V)**

No → Loose or poor contacts on the ECM coupler.  
 Open or short circuit in the Red wire or B/Br wire.

Yes ↓

- 2 Turn the ignition switch OFF.  
 Disconnect the TP sensor coupler (Black color).  
 Check the continuity between Yellow wire and ground.

**DATA** TP sensor continuity:  $\infty \Omega$  (Infinity)  
 (Yellow wire – Ground)

If OK, then measure the TP sensor resistance at the coupler (between Yellow and Black wires).  
 Turn the throttle grip and measure the resistance.

**DATA** TP sensor resistance

Throttle valve is closed: Approx. 1.1 k $\Omega$

Throttle valve is opened: Approx. 4.3 k $\Omega$

**09900-25008: Multi circuit tester**

**Tester knob indication: Resistance ( $\Omega$ )**

No → Reset the TP sensor position correctly.  
 Replace the TP sensor with a new one.

Yes ↓

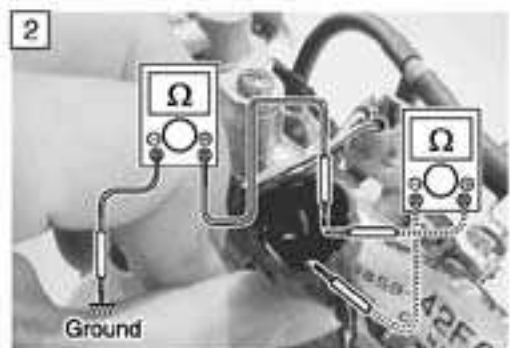
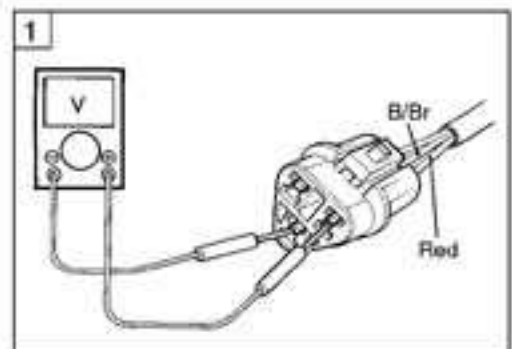
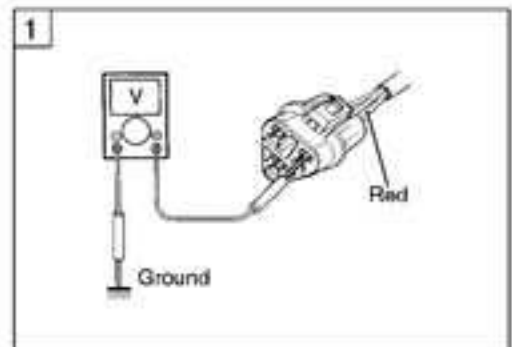

- 3 Connect the TP sensor coupler.  
 Insert the copper wires to the lead wire coupler.  
 Turn the ignition switch ON.  
 Measure the TP sensor output voltage at the coupler (between Yellow and Black wires) by turning the throttle grip.

**DATA TP sensor output voltage**

Throttle valve is closed: Approx. 1.1 V

Throttle valve is opened: Approx. 4.3 V

 09900-25008: Multi circuit tester

 Tester knob indication: Voltage (V)

- No → If check result is not satisfactory, replace TP sensor with a new one.
- Yes ↓

Red, P/B or B/Br wire open or shorted to ground, or poor ⑩, ⑪ or ⑫ connection. (☞ 4-22)

If wire and connection are OK, intermittent trouble or faulty ECM. Recheck each terminal and wire harness for open circuit and poor connection. (☞ 4-4)

- Replace the ECM with a new one, and inspect it again.

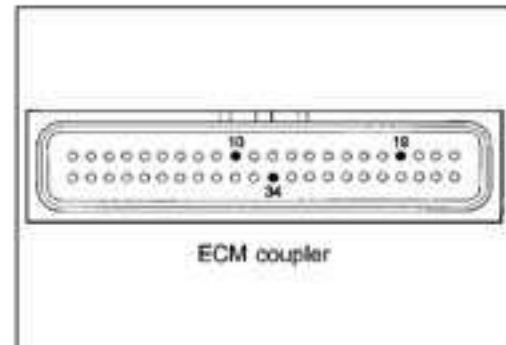
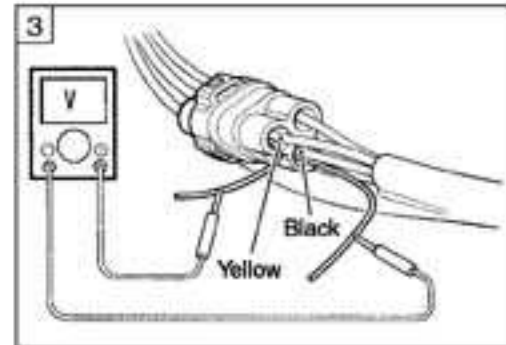

## "C15" EOT SENSOR CIRCUIT MALFUNCTION



DETECTED CONDITION	POSSIBLE CAUSE
High engine oil temp. (Low voltage – Low resistance)	<ul style="list-style-type: none"> <li>• B/BI circuit shorted to ground.</li> <li>• B/Br circuit open.</li> </ul>
Low engine oil temp. (High voltage – High resistance)	<ul style="list-style-type: none"> <li>• EOT sensor malfunction.</li> <li>• ECM malfunction.</li> </ul>

### INSPECTION

- Remove the right frame side cover. (☞ 6-3)

1 Turn the ignition switch OFF.  
Check the EOT sensor coupler for loose or poor contacts.  
If OK, then measure the EOT sensor voltage at the wire side coupler.  
Disconnect the coupler and turn the ignition switch ON.  
Measure the voltage between B/BI wire terminal and ground.  
If OK, then measure the voltage between B/BI wire terminal and B/Br wire terminal.

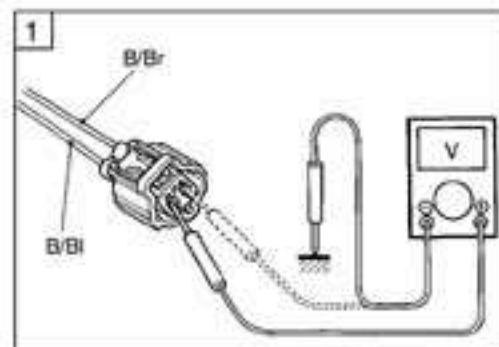

**DATA** EOT sensor voltage: 4.5 – 5.5 V  
 (⊕B/BI – ⊖Ground)  
 (⊕B/BI – ⊖B/Br)

 09900-25008: Multi circuit tester  
 Tester knob indication: Voltage (V)



2 Turn the ignition switch OFF.  
Measure the EOT sensor resistance.

**DATA** EOT sensor resistance: Approx. 61.3 kΩ at 20°C (68°F)  
(White lead wire – White lead wire)

 09900-25008: Multi circuit tester  
 Tester knob indication: Resistance (Ω)  
 Refer to page 5-11 for details.



B/BI or B/Br wire open or shorted to ground, or poor ⓐ or ⓑ connection. (☞ 4-22)  
If wire and connection are OK, intermittent trouble or faulty ECM.  
Recheck each terminal and wire harness for open circuit and poor connection. (☞ 4-4)

Replace the EOT sensor with a new one.

Replace the ECM with a new one, and inspect it again.

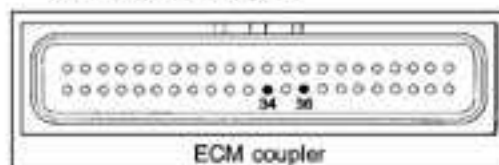

Engine Oil Temp.	Resistance
20°C ( 68 °F)	Approx. 61.3 kΩ
50°C (122 °F)	Approx. 17.8 kΩ
80°C (176 °F)	Approx. 6.2 kΩ
110°C (230 °F)	Approx. 2.5 kΩ

## "C21" IAT SENSOR CIRCUIT MALFUNCTION



DETECTED CONDITION	POSSIBLE CAUSE
High intake air temp. (Low voltage – Low resistance)	<ul style="list-style-type: none"> <li>• Dg circuit shorted to ground,</li> <li>• B/Br circuit open.</li> </ul>
Low intake air temp. (High voltage – High resistance)	<ul style="list-style-type: none"> <li>• IAT sensor malfunction.</li> <li>• ECM malfunction.</li> </ul>

### INSPECTION

- Remove the right frame side cover. (☞ 6-3)

1 Turn the ignition switch OFF.  
Check the IAT sensor coupler for loose or poor contacts.  
If OK, then measure the IAT sensor voltage at the wire side coupler.  
Disconnect the coupler and turn the ignition switch ON.  
Measure the voltage between Dg wire terminal and ground.  
If OK, then measure the voltage between Dg wire terminal and B/Br wire terminal.

**DATA** IAT sensor voltage: 4.5 – 5.5 V  
 (⊕ Dg – ⊖ Ground)  
 (⊕ Dg – ⊖ B/Br)

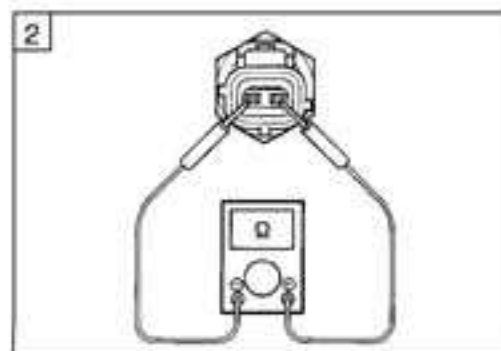
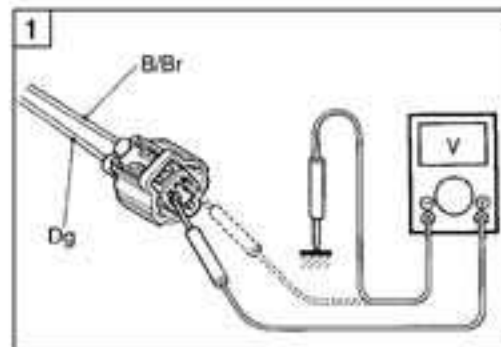

 09900-25008: Multi circuit tester  
 Tester knob indication: Voltage (V)



No → Loose or poor contacts on the ECM coupler.  
Open or short circuit in the Dg wire or B/Br wire.

2 Turn the ignition switch OFF.  
Measure the IAT sensor resistance.

**DATA** IAT sensor resistance: Approx. 2.6 kΩ at 20°C (68°F)  
(Terminal – Terminal)

 09900-25008: Multi circuit tester  
 Tester knob indication: Resistance (Ω)

No → Replace the IAT sensor with a new one.

Dg or B/Br wire open or shorted to ground, or poor ⓐ or ⓑ connection. (☞ 4-22)  
If wire and connection are OK, intermittent trouble or faulty ECM.  
Recheck each terminal and wire harness for open circuit and poor connection. (☞ 4-4)

Replace the ECM with a new one, and inspect it again.

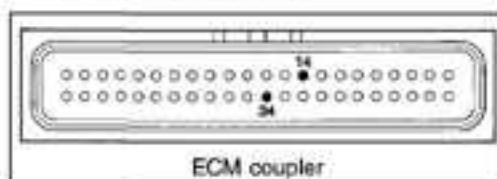

Intake Air Temp.	Resistance
20°C ( 68 °F)	Approx. 2.6 kΩ
50°C ( 122 °F)	Approx. 0.8 kΩ
80°C ( 176 °F)	Approx. 0.3 kΩ
110°C ( 230 °F)	Approx. 0.2 kΩ

#### NOTE:

IAT sensor resistance measurement method is the same way as that of the EOT sensor. Refer to page 5-11 for details.

## "C22" AP SENSOR CIRCUIT MALFUNCTION

DETECTED CONDITION	POSSIBLE CAUSE
Low pressure and low voltage. High pressure and high voltage. ( $0.20\text{ V} \leq \text{Sensor Voltage} < 4.80\text{ V}$ ) without the above range. <b>NOTE:</b> <i>Note that atmospheric pressure varies depending on weather conditions as well as altitude. Take that into consideration when inspecting voltage.</i>	<ul style="list-style-type: none"> <li>• Clogged air passage with dust.</li> <li>• Red wire circuit open or shorted to ground.</li> <li>• B/Br or G/Y wire circuit shorted to ground.</li> <li>• AP sensor malfunction.</li> <li>• ECM malfunction.</li> </ul>

### INSPECTION

- Remove the right frame side cover. (☞ 6-3)

- 1 Turn the ignition switch OFF.  
 Check the AP sensor coupler for loose or poor contacts.  
 If OK, then measure the AP sensor input voltage.  
 Turn the ignition switch ON.  
 Disconnect the AP sensor coupler.  
 Measure the voltage between Red wire and ground.  
 If OK, then measure the voltage between Red wire and B/Br wire.

**DATA** AP sensor input voltage: 4.5 – 5.5 V  
 ( ⊕Red – ⊖Ground )  
 ( ⊕Red – ⊖B/Br )

 09900-25008: Multi circuit tester

 Tester knob indication: Voltage (V)

No → Loose or poor contacts on the ECM coupler.  
 Open or short circuit in the Red wire or B/Br wire.

Yes ↓

- 2 Connect the AP sensor coupler.  
 Insert the copper wires to the lead wire coupler.  
 Turn the ignition switch ON.  
 Measure the AP sensor output voltage at the wire side coupler between G/Y and B/Br wires.

**DATA** AP sensor output voltage: Approx. 4.0 V  
 at 760 mmHg (100 kPa)  
 ( ⊕G/Y – ⊖B/Br )

 09900-25008: Multi circuit tester

 Tester knob indication: Voltage (V)

No → Check the air passage for clogging.  
 Open or short circuit in the G/Y wire.  
 Replace the AP sensor with a new one.

Yes ↓

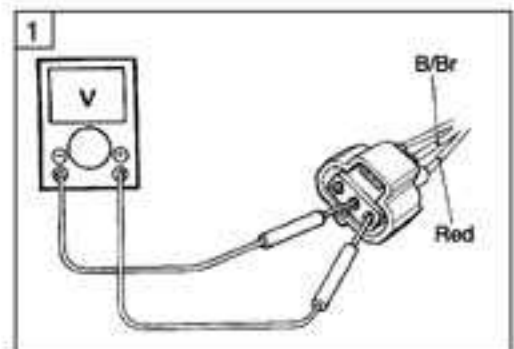
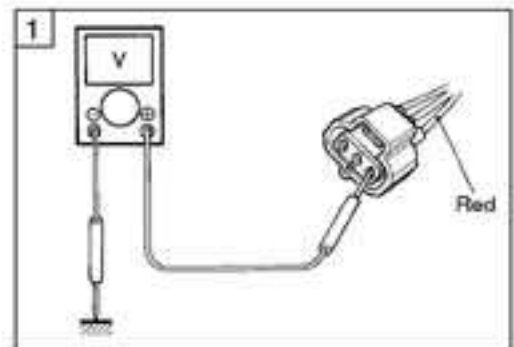

- 3 Remove the AP sensor.  
Connect the vacuum pump gauge to the air passage port of the AP sensor.  
Arrange 3 new 1.5 V batteries in series (check that total voltage is 4.5 – 5.0 V) and connect  $\ominus$  terminal to the ground terminal and  $\oplus$  terminal to the Vcc terminal.  
Check the voltage between Vout and ground. Also, check if voltage reduces when vacuum is applied up to 40 cmHg by using vacuum pump gauge. (See table below)

 09917-47010: Vacuum pump gauge  
09900-25008: Multi circuit tester

 Tester knob indication: Voltage (---)

No → If check result is not satisfactory, replace AP sensor with a new one.  
Yes ↓

Red, G/Y or B/Br wire open or shorted to ground, or poor ⑩, ⑪ or ⑬ connection. (☞ 4-22)  
If wire and connection are OK, intermittent trouble or faulty ECM.  
Recheck each terminal and wire harness for open circuit and poor connection. (☞ 4-4)

→ Replace the ECM with a new one, and inspect it again.

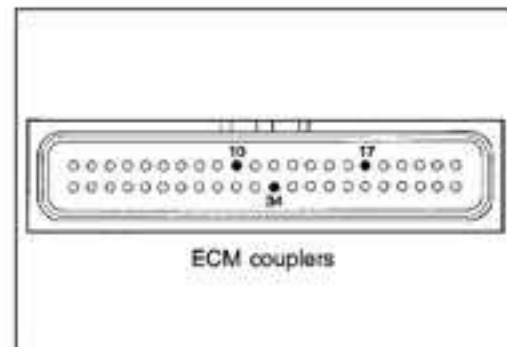
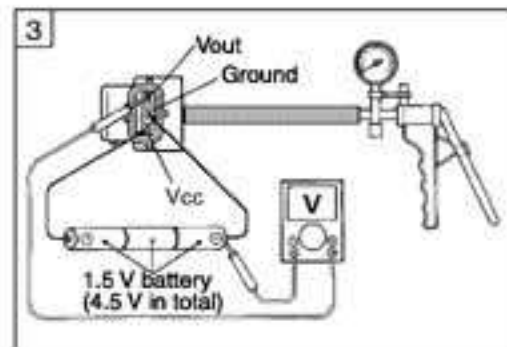

**OUTPUT VOLTAGE (VCC VOLTAGE 4.5 – 5.0 V, AMBIENT TEMP. 20 – 30°C, 68 – 86°F)**

ALTITUDE (Reference)		ATMOSPHERIC PRESSURE		OUTPUT VOLTAGE
(ft)	(m)	(mmHg)	kPa	(V)
0	0	760	100	3.4 – 4.0
2 000	610	707	94	
2 001	611	707	94	2.8 – 3.7
5 000	1 524	634	85	
5 001	1 525	634	85	2.6 – 3.4
8 000	2 438	567	76	
8 001	2 439	567	76	2.4 – 3.1
10 000	3 048	526	70	



## "C23" TO SENSOR CIRCUIT MALFUNCTION

DETECTED CONDITION	POSSIBLE CAUSE
No TO sensor signal for more than 2 seconds, after ignition switch turns ON. Sensor voltage high. ( Sensor Voltage < 3.90 V ) ( without the above value. )	<ul style="list-style-type: none"> <li>• TO sensor circuit open or short.</li> <li>• TO sensor malfunction.</li> <li>• ECM malfunction.</li> </ul>

### INSPECTION

- Remove the right frame side cover. (☞ 6-3)

1 Turn the ignition switch OFF.  
Check the TO sensor coupler for loose or poor contacts.  
If OK, then measure the TO sensor resistance.  
Disconnect the TO sensor coupler.  
Measure the resistance between Black and B/W wire terminals.

**DATA** TO sensor resistance: 60 – 64 k $\Omega$   
(Black – B/W)

**09900-25008: Multi circuit tester**

**Tester knob indication: Resistance ( $\Omega$ )**



No → Replace the TO sensor with a new one.

Yes →

2 Connect the TO sensor coupler.  
Insert the copper wires to the wire lead coupler.  
Turn the ignition switch ON.  
Measure the voltage at the wire side coupler between Brown and B/Br wires.

**DATA** TO sensor voltage: Approx. 3.8 V (Brown – B/Br)

Also, measure the voltage when leaning of the motorcycle.  
Dismount the TO sensor from its bracket and measure the voltage when it is leaned more than 43°, left and right, from the horizontal level.

**DATA** TO sensor voltage: 0 V (Brown – B/Br)

**09900-25008: Multi circuit tester**

**Tester knob indication: Voltage (V)**

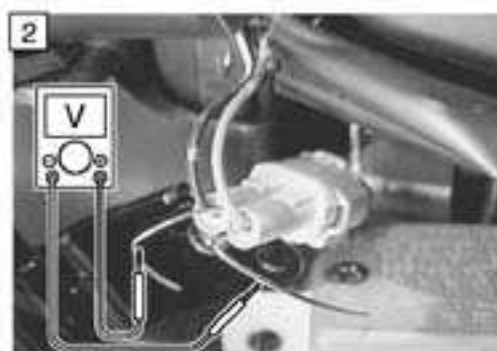
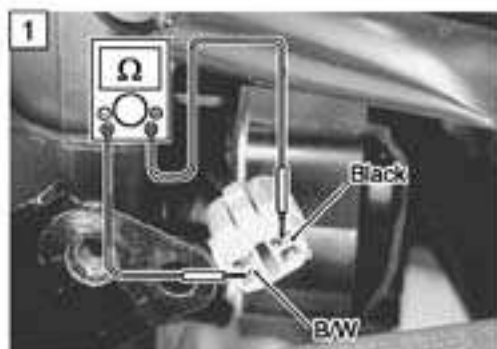

No → Loose or poor contacts on the ECM coupler.  
Open or short circuit in the Brown wire or B/Br wire.  
Replace the TO sensor with a new one.

Yes →

Brown or B/Br wire open or shorted to ground, or poor ④ or ⑤ connection. (☞ 4-22)  
If wire and connection are OK, intermittent trouble or faulty ECM.  
Recheck each terminal and wire harness for open circuit and poor connection. (☞ 4-4)

Replace the ECM with a new one, and inspect it again.

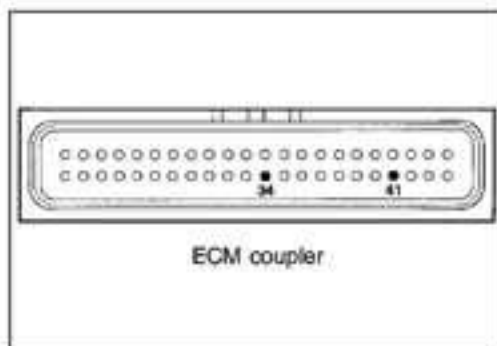

**"C24" or "C25" IGNITION SYSTEM MALFUNCTION**

\*REFER TO THE IGNITION SYSTEM FOR DETAILS. (☞7-20)

**"C28" STV ACTUATOR CIRCUIT MALFUNCTION**

DETECTED CONDITION	POSSIBLE CAUSE
The operation voltage does not reach the STVA. ECM does not receive communication signal from the STVA.	<ul style="list-style-type: none"> <li>• STVA malfunction.</li> <li>• STVA circuit open or short.</li> <li>• STVA motor malfunction.</li> </ul>

**INSPECTION**

- Lift and support the fuel tank with a proper stay. (☞4-48)

1 Turn the ignition switch OFF.  
Check the STVA lead wire coupler for loose or poor contacts.  
Disconnect the STVA lead wire coupler.  
Check the continuity between Red wire and ground.

**DATA** STVA continuity:  $\infty\Omega$  (Infinity)

If OK, then measure the STVA resistance. (between Red and Black wires)

**DATA** STVA resistance: Approx. 4.8 – 7.2  $\Omega$   
(+ Red – - Black)

**TOOL** 09900-25008: Multi circuit tester

**TESTER** Tester knob indication: Resistance ( $\Omega$ )

No → Replace the STVA with a new one.

Yes

Loose or poor contacts on the STVA coupler, or poor Ⓜ or Ⓜ connection. (☞4-22)

If wire and connection are OK, intermittent trouble or faulty ECM. Recheck each terminal and wire harness for open circuit and poor connection. (☞4-4)

→ Replace the ECM with new one, and inspect it again.

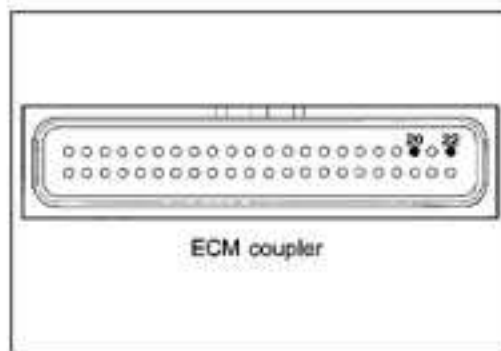
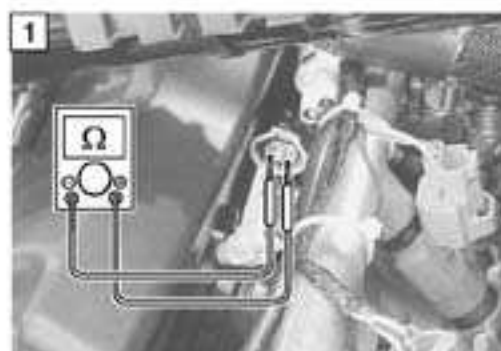

## "C29" STP SENSOR CIRCUIT MALFUNCTION

DETECTED CONDITION	POSSIBLE CAUSE
Signal voltage low or high. Difference between actual throttle opening and opening calculated by ECM is larger than specified value. $(0.20\text{ V} \leq \text{Sensor Voltage} < 4.80\text{ V})$ (without the above range.)	<ul style="list-style-type: none"> <li>• STP sensor maladjusted.</li> <li>• STP sensor circuit open or short.</li> <li>• STP sensor malfunction.</li> <li>• ECM malfunction.</li> </ul>

### INSPECTION

- Remove the fuel tank. (☞ 4-48)

- 1 Turn the ignition switch OFF.  
 Check the STP sensor coupler for loose or poor contacts.  
 If OK, then measure the STP sensor input voltage.  
 Disconnect the STP sensor coupler (White color).  
 Turn the ignition switch ON.  
 Measure the voltage at the Red wire and ground.  
 If OK, then measure the voltage at the Red wire and B/Br wire.

**DATA** STP sensor input voltage: 4.5 – 5.5 V

$$\left( \begin{array}{l} \oplus \text{Red} - \ominus \text{Ground} \\ \oplus \text{Red} - \ominus \text{B/Br} \end{array} \right)$$

**TEC** 09900-25008: Multi circuit tester

**TEST** Tester knob indication: Voltage (V)

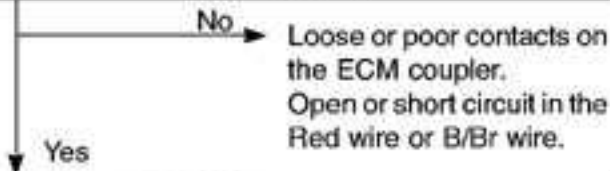

- 2 Turn the ignition switch OFF.  
 Remove the air cleaner element. (☞ 2-4)  
 Disconnect the STP sensor coupler (White color).  
 Check the continuity between Yellow wire and ground.

**DATA** STP sensor continuity:  $\infty\Omega$  (Infinity)  
 (Yellow wire – Ground)

If OK, then measure the STP sensor resistance at the coupler (between Yellow and Black wires).  
 Close and open the secondary throttle valve by finger through the air cleaner box, and measure the valve closing and opening resistance.

**DATA** STP sensor resistance

Secondary throttle valve is closed: Approx. 0.8 k $\Omega$

Secondary throttle valve is opened: Approx. 3.9 k $\Omega$

**TEC** 09900-25008: Multi circuit tester

**TEST** Tester knob indication: Resistance ( $\Omega$ )

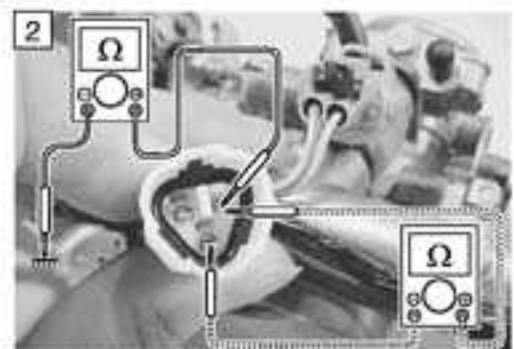
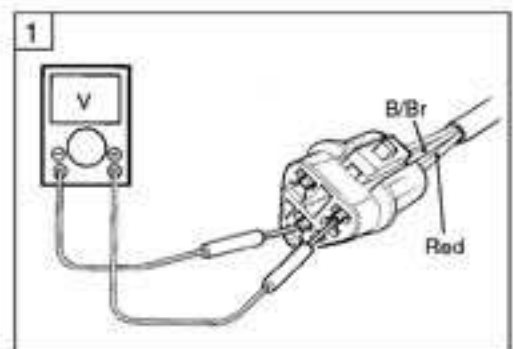
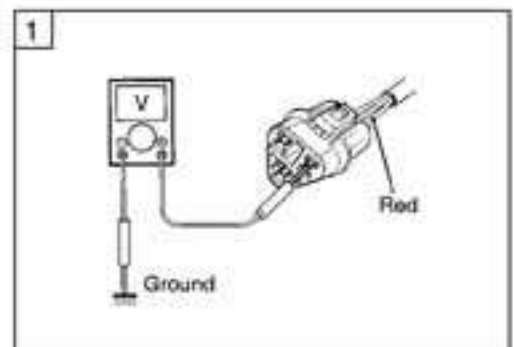
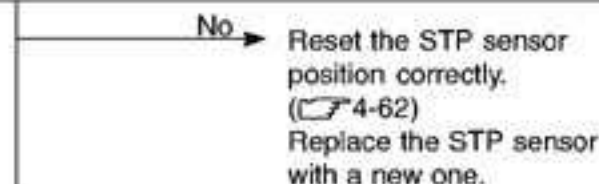

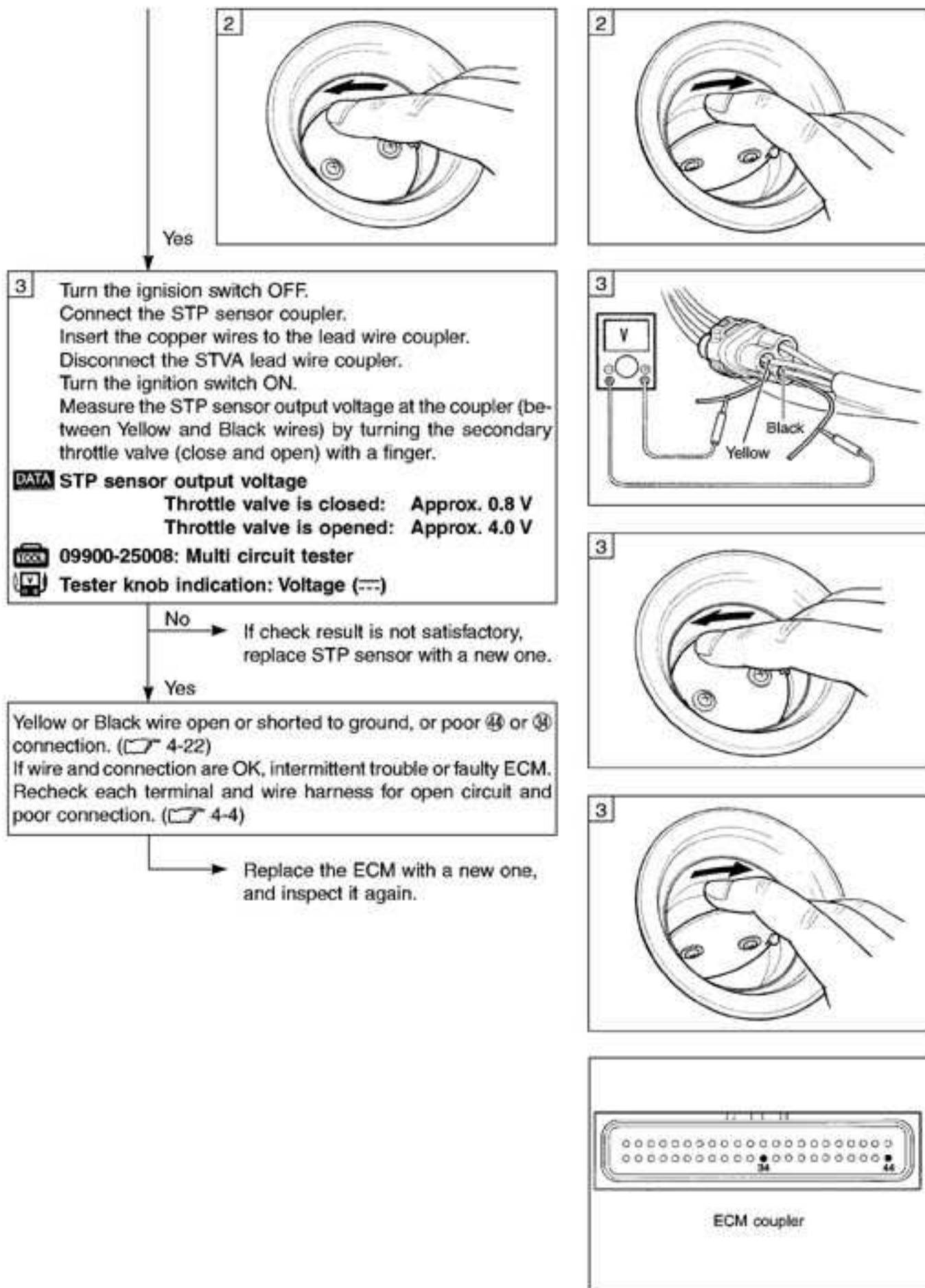

## "C31" GEAR POSITION (GP) SWITCH CIRCUIT MALFUNCTION

DETECTED CONDITION	POSSIBLE CAUSE
No Gear Position switch voltage Switch voltage low. ( Switch Voltage > 0.6 V without the above value. )	<ul style="list-style-type: none"> <li>• Gear Position switch circuit open or short.</li> <li>• Gear Position switch malfunction.</li> <li>• ECM malfunction.</li> </ul>

### INSPECTION

- Remove the left frame side cover. (☞ 6-3)

1 Turn the ignition switch OFF.  
Check the GP switch coupler for loose or poor contacts.  
If OK, then measure the GP switch voltage.  
Support the motorcycle with the center stand.  
Turn the side-stand to up-right position.  
Turn the engine stop switch ON.  
Insert the copper wire to the lead wire coupler.  
Turn the ignition switch ON.  
Measure the voltage at the wire side coupler between Pink wire and ground, when shifting the gearshift lever from 1st to Top.

**DATA** GP switch voltage: More than 0.6 V  
(Pink – Ground)

**BOOK** 09900-25008: Multi circuit tester

**TESTER** Tester knob indication: Voltage (---)

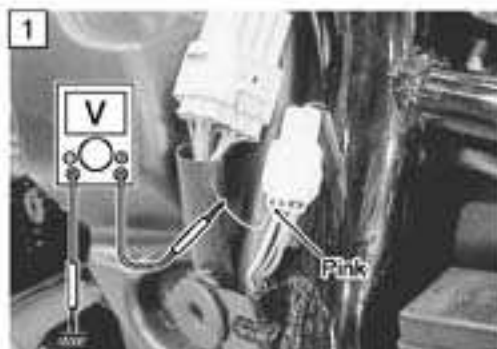

No → Open or short circuit in the Pink wire.  
Replace the GP switch with a new one.

Yes

Pink wire open or shorted to ground, or poor Ⓢ connection. (☞ 4-22)  
If wire and connection are OK, intermittent trouble or faulty ECM.  
Recheck each terminal and wire harness for open circuit and poor connection. (☞ 4-4)

→ Replace the ECM with a new one, and inspect it again.

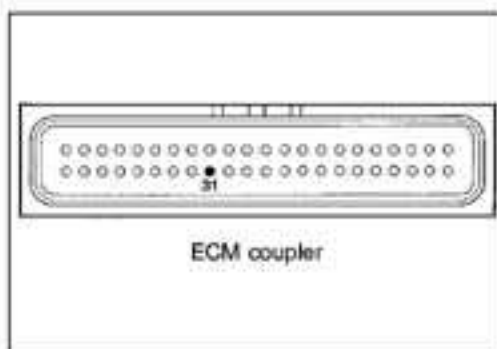



## "C32", "C33", "C34" or "C35" FUEL INJECTION MALFUNCTION

DETECTED CONDITION	POSSIBLE CAUSE
No injector current.	<ul style="list-style-type: none"> <li>• Injector circuit open or short.</li> <li>• Injector malfunction.</li> <li>• ECM malfunction.</li> </ul>

### INSPECTION

- Lift and support the fuel tank with a proper stay. (☞ 4-48)

**1** Turn the ignition switch OFF.  
Check the injector coupler for loose or poor contacts.  
If OK, then measure the injector resistance.  
Disconnect the coupler and measure the resistance between terminals.

**DATA** Injector resistance:  $12 - 18 \Omega$  at  $20^{\circ}\text{C}$  ( $68^{\circ}\text{F}$ )  
(Terminal - Terminal)

If OK, then check the continuity between each terminal and ground.

**DATA** Injector continuity:  $\infty\Omega$  (Infinity)  
(Terminal - Ground)

**BOOK** 09900-25008: Multi circuit tester

**TESTER** Tester knob indication: Resistance ( $\Omega$ )

No → Replace the injector with a new one. (☞ 4-64)

Yes

**2** Turn the ignition switch ON.  
Measure the injector voltage between Y/R wire and ground.

**DATA** Injector voltage: Battery voltage  
(Y/R - Ground)

**NOTE:**  
Injector voltage can be detected only 3 seconds after ignition switch is turned ON.

**BOOK** 09900-25008: Multi circuit tester

**TESTER** Tester knob indication: Voltage (V)

No → Open circuit in the Yellow/Red wire.

Yes

Gr/W, Gr/B, Gr/Y, Gr/R or Y/R wire open or shorted to ground, or poor ⑤, ⑥, ⑦, ⑧ or ⑨ connection. (☞ 4-22)  
If wire and connection are OK, intermittent trouble or faulty ECM.  
Recheck each terminal and wire harness for open circuit and poor connection. (☞ 4-4)

→ Replace the ECM with a new one, and inspect it again.

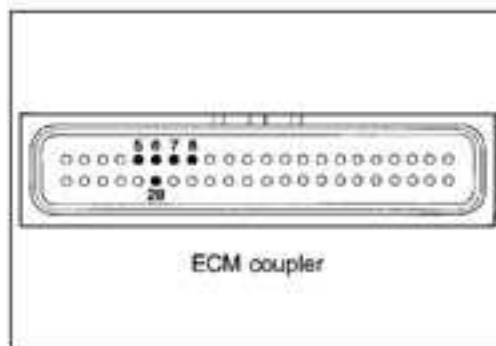
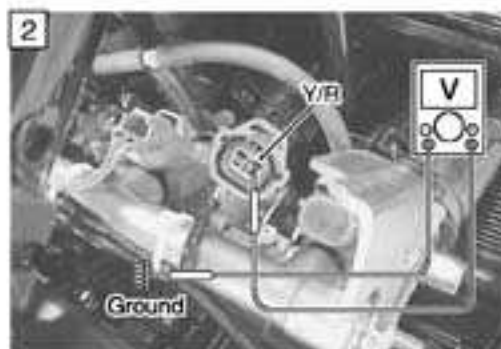
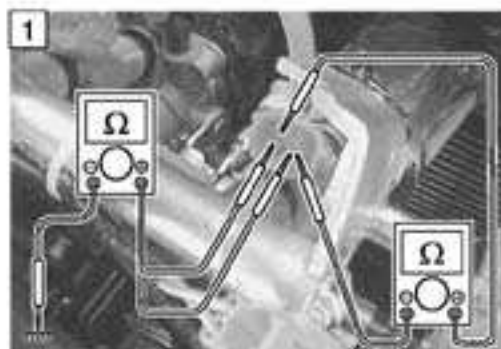
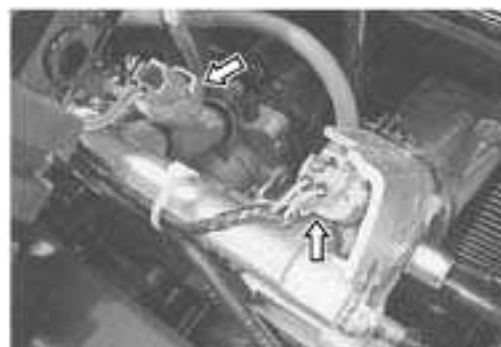



## “C41” FP RELAY CIRCUIT MALFUNCTION

DETECTED CONDITION	POSSIBLE CAUSE
No signal from fuel pump relay.	<ul style="list-style-type: none"> <li>Fuel pump relay circuit open or short.</li> <li>Fuel pump relay malfunction.</li> <li>ECM malfunction.</li> </ul>

### INSPECTION

- Remove the left frame side cover. (☞ 6-3)

1 Turn the ignition switch OFF.  
Check the FP relay coupler for loose or poor contacts.  
If OK, then check the insulation and continuity. Refer to page 4-51 for details.

No → Replace the FP relay with a new one.

Yes ↓

Y/B or O/W wire open or shorted to ground, or poor Ⓜ or Ⓢ connection. (☞ 4-22)  
If wire and connection are OK, intermittent trouble or faulty ECM.  
Recheck each terminal and wire harness for open circuit and poor connection. (☞ 4-4)

→ Replace the ECM with a new one, and inspect it again.

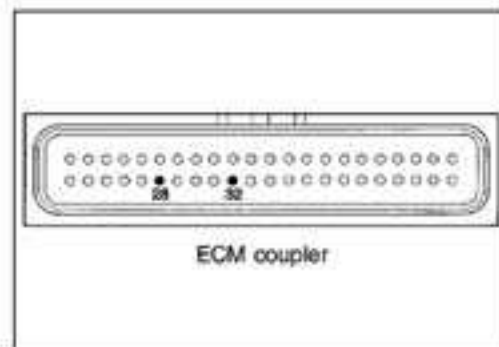

## “C42” IG SWITCH CIRCUIT MALFUNCTION

- Refer to the IGNITION SWITCH INSPECTION for details.
- Remove the headlight. (☞ 6-24)
- Inspect the ignition switch. (☞ 7-29)



## FUEL SYSTEM

### FUEL TANK REMOVAL

- Remove the seat and frame side covers, left and right. (☞ 6-3)
  - Remove the fuel tank mounting bolts.
  - Lift and support the fuel tank with a proper stay.
- 
- Place a rag under the fuel feed hose and remove the fuel feed hose ①.
  - Disconnect the fuel pump lead wire coupler ② and fuel level gauge lead wire coupler ③.

#### CAUTION

When removing the fuel feed hose ①, disconnect the fuel delivery pipe side first and fuel tank side last. Do not remain the fuel feed hose ① at the fuel tank side.

#### ⚠ WARNING

Gasoline is highly flammable and explosive. Keep heat, spark and flame away.

- Remove the fuel tank.

### FUEL TANK INSTALLATION

- Installation is in the reverse order of removal.

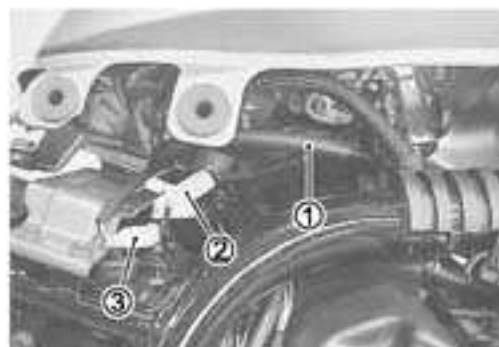

## FUEL PRESSURE INSPECTION

- Remove the seat and frame side covers, left and right. (☞ 6-3)
- Lift and support the fuel tank with a proper stay. (☞ 4-48)
- Place a rag under the fuel feed hose. (☞ 4-48)
- Remove the fuel feed hose and install the special tools between the fuel tank and fuel delivery pipe.

- TOOL** 09940-40211: Fuel pressure gauge adaptor  
 09940-40220: Fuel pressure gauge hose attachment  
 09915-77330: Oil pressure gauge  
 09915-74520: Oil pressure gauge hose

Turn the ignition switch ON and check the fuel pressure.

**DATA** Fuel pressure: Approx. 300 kPa (3.0 kgf/cm<sup>2</sup>, 43 psi)

If the fuel pressure is lower than the specified, inspect the following items:

- Fuel hose leakage
- Clogged fuel filter
- Pressure regulator
- Fuel pump

If the fuel pressure is higher than the specified, inspect the following items:

- Fuel pump check valve
- Pressure regulator

### ⚠ WARNING

- Before removing the special tools, turn the ignition switch OFF position and release the fuel pressure slowly.
- Gasoline is highly flammable and explosive. Keep heat, sparks and flame away.

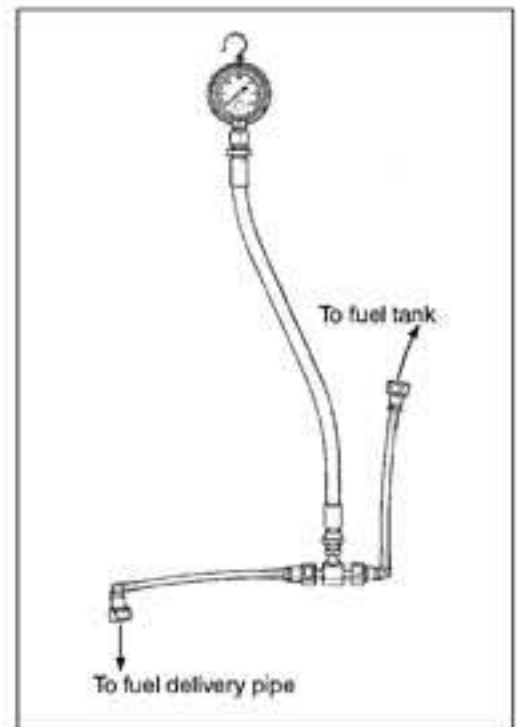

## FUEL PUMP INSPECTION

Turn the ignition switch ON and check that the fuel pump operates for few seconds.

If the fuel pump motor does not make operating sound, replace the fuel pump assembly or inspect the fuel pump relay and tip over sensor.

## FUEL DISCHARGE AMOUNT INSPECTION

### ⚠ WARNING

Gasoline is highly flammable and explosive.  
Keep heat, spark and flame away.

- Remove the seat and frame side covers, left and right. (☞ 6-3)
- Lift and support the fuel tank with a proper stay. (☞ 4-48)
- Disconnect the fuel feed hose from the fuel delivery pipe.
- Place the measuring cylinder and insert the fuel feed hose end into the measuring cylinder.
- Disconnect the ECM lead wire coupler.
- Push the lock (A) to pull out the power source lead wire (Yellow with red tracer).

- Apply 12 volts to the fuel pump for 30 seconds and measure the amount of fuel discharged.

Battery (+) terminal — Power source lead wire (1)  
(Yellow with red tracer)

If the discharge amount is not specified it means that the fuel pump is defective or that the fuel filter is clogged.

**DATA** Fuel discharge amount: Approx. 1 200 ml/30 sec.  
(1.3/1.1 US/imp oz)/30 sec.

### NOTE:

The battery must be in fully charged condition.



## FUEL PUMP RELAY INSPECTION

Fuel pump relay is located behind the left frame side cover.

- Remove the seat and left frame side cover. (☞6-3)
- Remove the fuel pump relay.

First, check the insulation between ① and ② terminals with pocket tester. Then apply 12 volts to ③ and ④ terminals,  $\oplus$  to ③ and  $\ominus$  to ④, and check the continuity between ① and ②.

If there is no continuity, replace it with a new one.

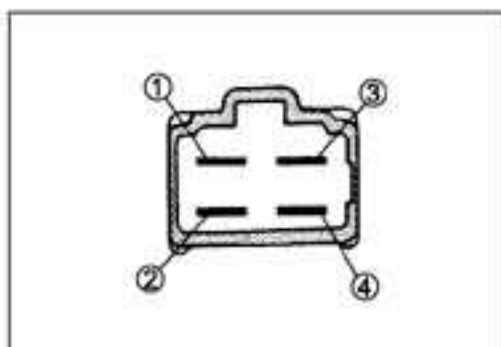

## FUEL PUMP AND FUEL FILTER REMOVAL

- Remove the fuel tank. (☞4-48)
- Remove the fuel pump assembly by removing its mounting bolts diagonally.

### ⚠ WARNING

Gasoline is highly flammable and explosive.  
Keep heat, spark and flame away.

- Remove the nut.



- Remove the screws.

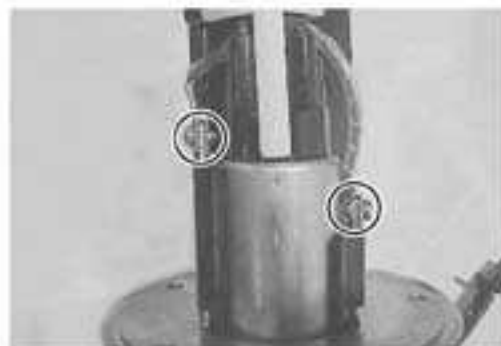

- Remove the fuel pump assy from the fuel pump plate.

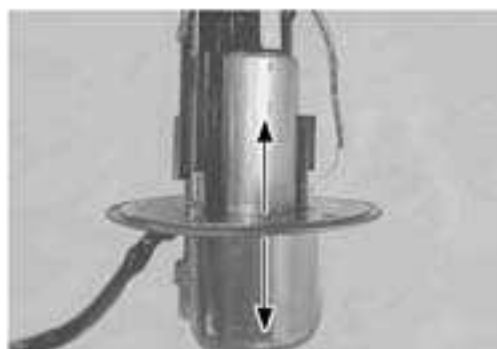

- Remove the fuel pump holder.



- Remove the fuel mesh filter.



- Remove the fuel pressure regulator holder ① and the fuel pressure regulator ②.



## FUEL MESH FILTER INSPECTION AND CLEANING

If the fuel mesh filter is clogged with sediment or rust, fuel will not flow smoothly and loss in engine power may result.

Blow the fuel mesh filter with compressed air.

### NOTE:

*If the fuel mesh filter is clogged with many sediment or rust, replace the fuel filter cartridge with a new one.*





## FUEL PUMP AND FUEL MESH FILTER INSTALLATION

Install the fuel pump and fuel mesh filter in the reverse order of removal, and pay attention to the following points:

- Install the new O-rings to the fuel pressure regulator and fuel pipe.
- Apply thin coat of the engine oil to the O-rings.

### CAUTION

Use the new O-rings to prevent fuel leakage.

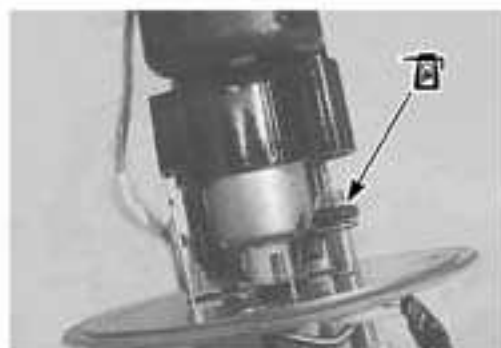

- Tighten the screws together with the lead wire terminals.



- Tighten the nut together with the lead wire terminal.



- Install the new O-ring and apply grease to it.

### WARNING

The O-ring must be replaced with a new one to prevent fuel leakage.

 99000-25010: SUZUKI SUPER GREASE "A"



- When installing the fuel pump assembly, lightly tighten all the fuel pump assembly mounting bolts in the ascending order of numbers, and then tighten them to the specified torque in the above manner.

 Fuel pump mounting bolt: 10 N·m (1.0 kgf·m, 7.3 lb-ft)

**NOTE:**

Apply a small quantity of the **THREAD LOCK "1342"** to the thread portion of the fuel pump mounting bolt.

 **99000-32050: THREAD LOCK "1342"**

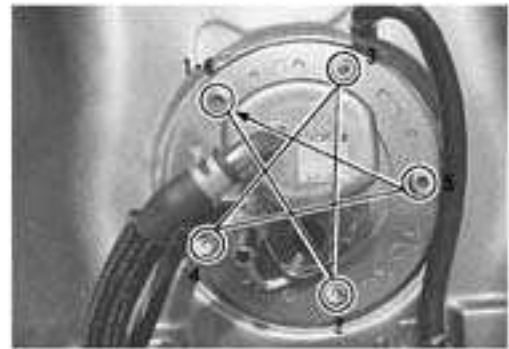

## THROTTLE BODY AND STV ACTUATOR CONSTRUCTION

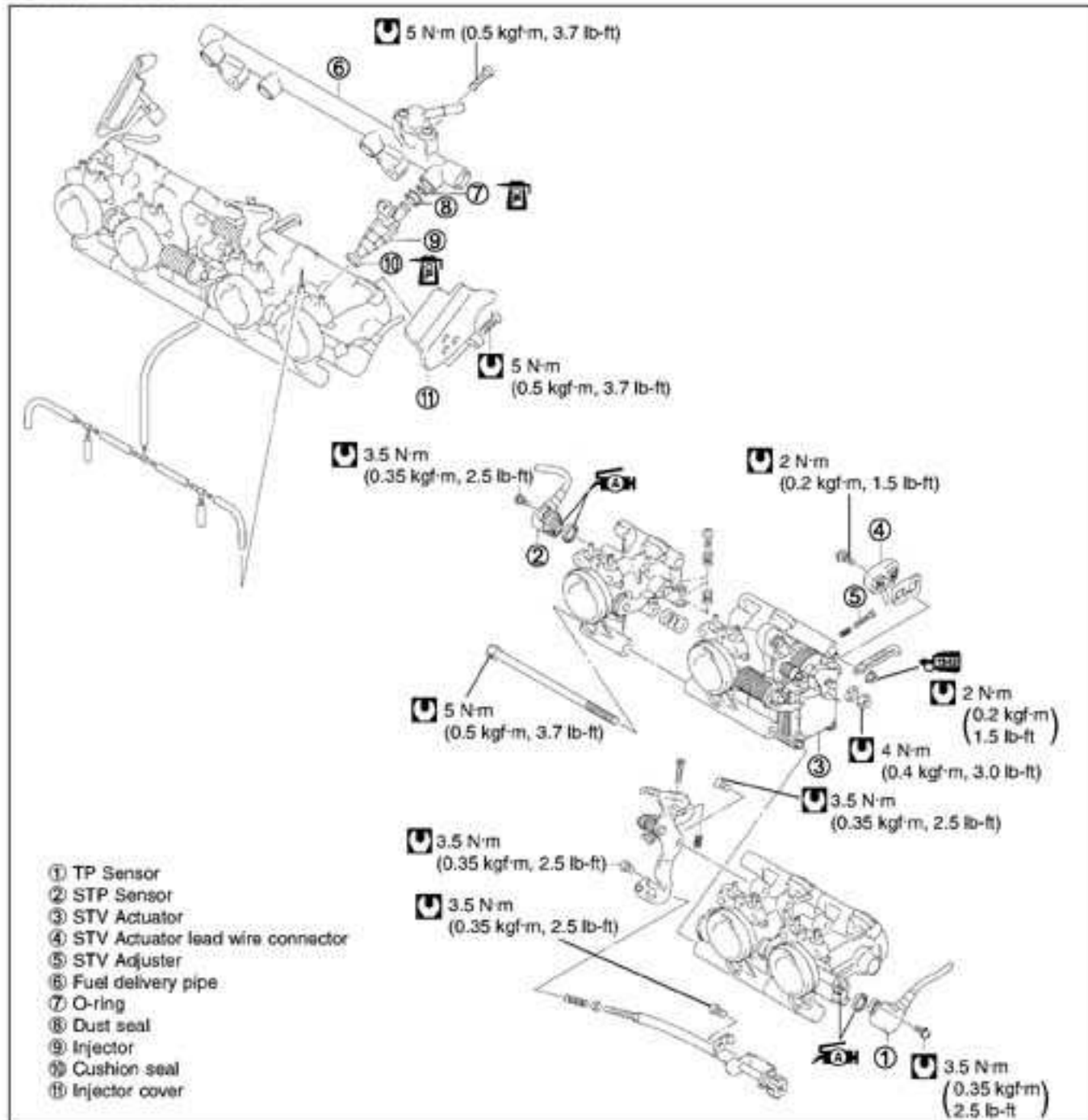

## THROTTLE BODY REMOVAL

- Remove the fuel tank. (☞ 4-48)
- Disconnect the fuel injector/sensor lead wire coupler ①.



- Loosen the respective throttle body clamp screws.



- Remove the air cleaner box mounting bolts, left and right.



- Slightly move the air cleaner box backward.



- Disconnect the throttle cables from their drum.
- Disconnect the vacuum hose ① from the IAP sensor.
- Dismount the throttle body assembly.

**CAUTION**

- Be careful not to damage the throttle cable bracket and fast idle lever when dismounting or remounting the throttle body assembly.
- After disconnecting the throttle cables, do not snap the throttle valve from full open to full close. It may cause damage to the throttle valve and throttle body.

**THROTTLE BODY DISASSEMBLY**

- Disconnect the respective vacuum hoses from each throttle body.

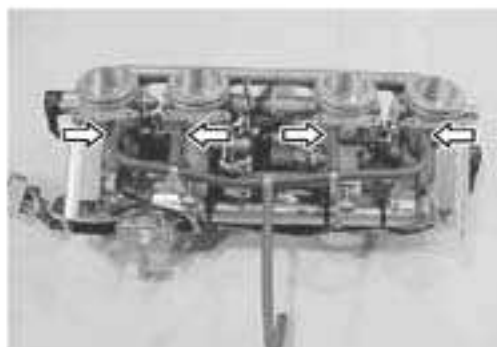

- Remove the lead wire clamps.
- Disconnect the TP sensor lead wire coupler ①, STP sensor lead wire coupler ②, STVA motor lead wire coupler ③.

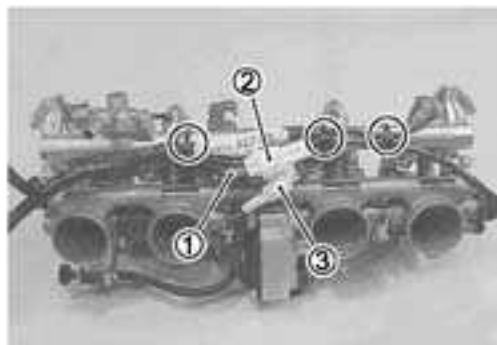

- Disconnect the fuel injector lead wire couplers.

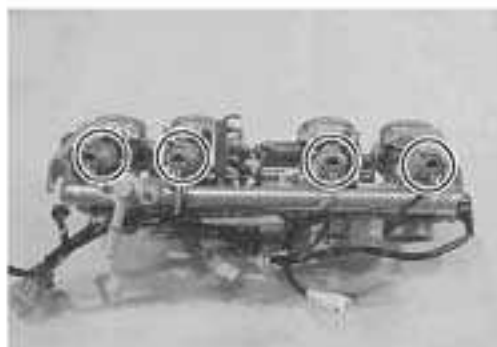

- Remove the fuel delivery pipe assembly by removing its mounting screws.

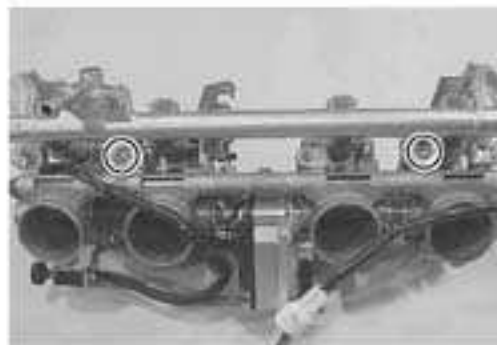

- Remove the fuel injectors.

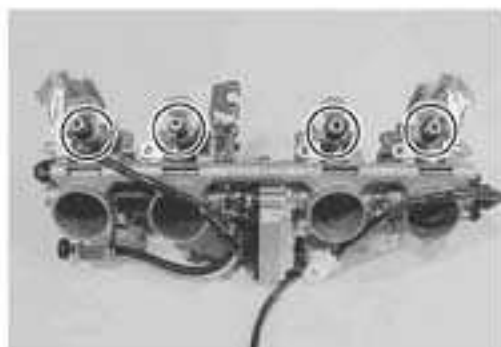

- Separate the throttle body assembly to a pair of two bodies (NO.1/NO.2 and NO.3/NO.4) by removing their connecting bolts.



- Remove the TP sensor with the special tool.

 09930-11960: Torx wrench

**NOTE:**

Prior to disassembly, mark the TP sensor's original position with a paint or scribe for accurate reinstallation.



- Remove the STP sensor with the special tool.

 09930-11960: Torx wrench

**NOTE:**

Prior to disassembly, mark the STP sensor's original position with a paint or scribe for accurate reinstallation.



- Remove the fast idle cam ① by removing its mounting nut.

**CAUTION**

Do not attempt to disassemble the secondary throttle valve actuator assembly. (Except for the cover ②)  
Actuator is available only as an assembly.

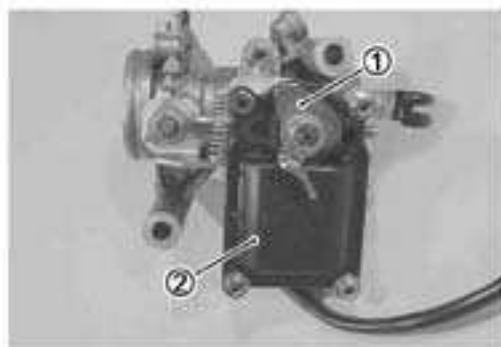

- Remove the STVA motor lead wire connector ① by removing the screw.

**CAUTION**

Never remove the STVA motor yoke and motor.

**CAUTION**

Avoid removing the STV adjuster (A) unless absolutely necessary.

**CAUTION**

Never remove the throttle valve and secondary throttle valve.

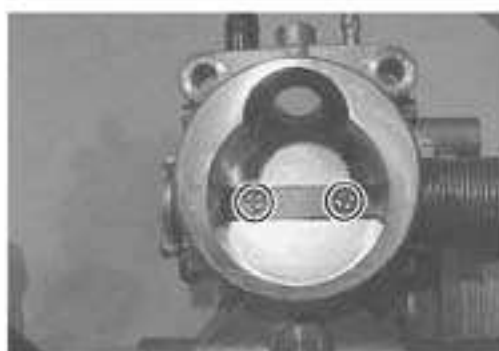



## THROTTLE BODY CLEANING

### ⚠ WARNING

Some carburetor cleaning chemicals, especially dip-type soaking solutions, are very corrosive and must be handled carefully. Always follow the chemical manufacturer's instructions on proper use, handling and storage.

- Clean all passageways with a spray-type carburetor cleaner and blow dry with compressed air.

### CAUTION

Do not use wire to clean passageways. Wire can damage passageways. If the components cannot be cleaned with a spray cleaner it may be necessary to use a dip-type cleaning solution and allow them to soak. Always follow the chemical manufacturer's instructions for proper use and cleaning of the throttle body components. Do not apply carburetor cleaning chemicals to the rubber and plastic materials.

## INSPECTION

Check following items for any damage or clogging.

- O-ring
- Throttle shaft bushing and seal
- Throttle valve
- Secondary throttle valve
- Fuel injector filter
- Injector cushion seal
- Injector dust seal
- Vacuum hose

## THROTTLE BODY REASSEMBLY

Reassemble the throttle body in the reverse order of disassembly.

Pay attention to the following points:

- Be careful not to apply grease to the other parts when applying the grease to the shaft.

 99000-25010: SUZUKI SUPER GREASE "A"

- Install the actuator cover ①.

### NOTE:

Before installing the cover ①, apply grease lightly to the dust seal ②.

 99000-25010: SUZUKI SUPER GREASE "A"

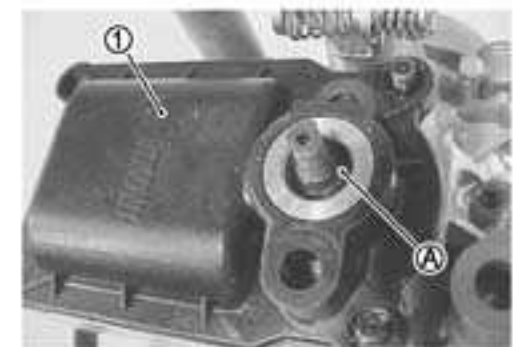

- Apply thread lock "1342" to the actuator cover nuts and tighten them.

 99000-32050: THREAD LOCK "1342"

 STVA cover nut: 2.0 N·m (0.2 kgf·m, 1.5 lb-ft)

- Install the fast idle cam and tighten its mounting nut.

 Fast idle cam mounting nut: 4.0 N·m (0.4 kgf·m, 3.0 lb-ft)

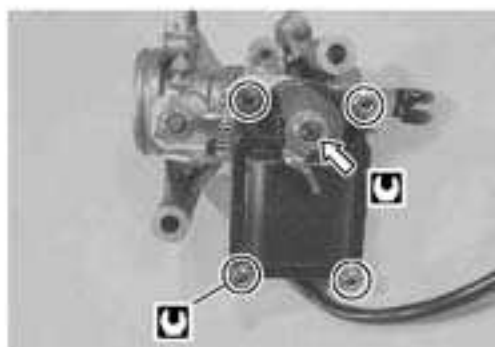

- Position the TV control lever between the TV synchronizing screw and spring as shown.
- Set each TV to the same opening by turning the balance screws.

**NOTE:**

*Apply grease "A" to the screw end and spring if necessary.*

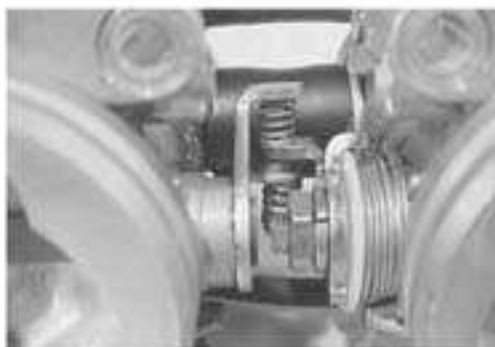

- Position the STV control lever between the STV balance screw and spring as shown.



- Place the throttle body assembly on the surface plate and tighten the connecting bolts.

**Throttle body connecting bolt: 5 N·m  
(0.5 kgf·m, 3.7 lb-ft)**



- Apply thin coat of the engine oil to the new fuel injector cushion seals ①, and install them to each fuel injector.

**CAUTION**

Replace the cushion seal with a new one.

- Install the seals ② and O-rings ③ to each fuel injector.
- Apply thin coat of the engine oil to the new O-rings ③.
- Install the fuel injectors by pushing them straight to each throttle body.



**CAUTION**

Replace the dust seal and O-ring with the new ones.  
Never turn the injector while pushing it.

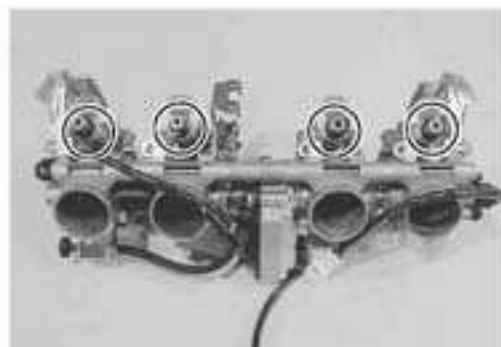

- Install the fuel delivery pipe assembly to the throttle body assembly.

**CAUTION**

Never turn the fuel injectors while installing them.

- Tighten the fuel delivery pipe mounting screws (A).

**Fuel delivery pipe mounting screw: 5 N·m  
(0.5 kgf·m, 3.7 lb-ft)**

- Connect the fuel injector couplers to each fuel injector.

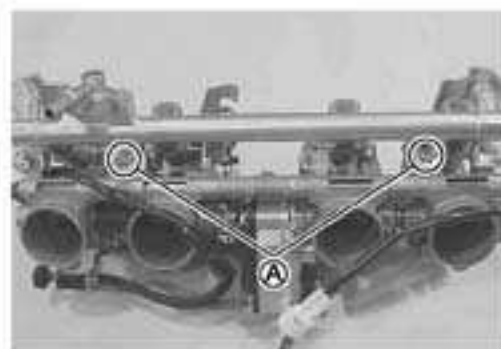

**WIRE COLOR**

No.1 coupler: Gray/ White

No.2 coupler: Gray/ Black

No.3 coupler: Gray/ Yellow

No.4 coupler: Gray/ Red

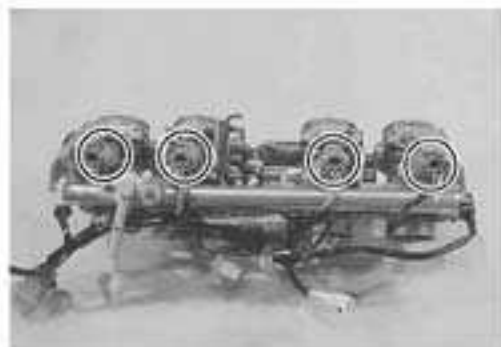

- Set the No.3 and No.4 STV's to the same opening by turning the balance screw ①. Then, set the No.1/No.2 valves and No.3/No.4 valves to the same opening by turning the balance screw ②.



- Install the TP sensor to the No.1 throttle body and STP sensor to the No.4 throttle body respectively.

 09930-11960: Torx wrench

**NOTE:**

- Apply grease "A" to the shaft end (A) if necessary.
- STP sensor and TP sensor resemble each other very closely in external appearance. Make sure to check the color of coupler before connecting.



White coupler: STP sensor, Black coupler: TP sensor

### STP SENSOR ADJUSTMENT

If the STP sensor adjustment is necessary, measure the sensor resistance and adjust the STP sensor positioning as follows:

- Disconnect the STP sensor coupler.
- Set the ST valve to fully close position by finger and measure the resistance between yellow and black wires.

 **DATA** STP sensor setting resistance

ST valve is fully closed: Approx. 0.8 k $\Omega$   
(+ Yellow - - Black)

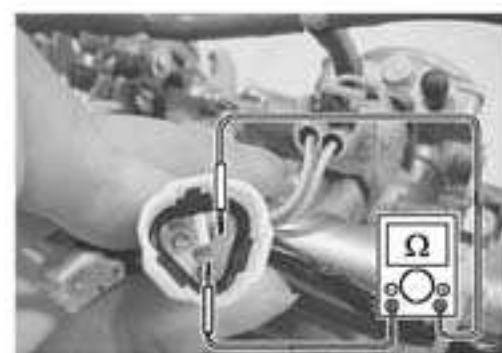

 09900-25008: Multi circuit tester

 **Tester knob indication: Resistance ( $\Omega$ )**

- Loosen the STP sensor mounting screws.
- Adjust the STP sensor until resistance is within specification and tighten the STP sensor mounting screws.

 09930-11960: Torx wrench

 **STP sensor mounting screw: 3.5 N·m  
(0.35 kgf·m, 2.5 lb·ft)**

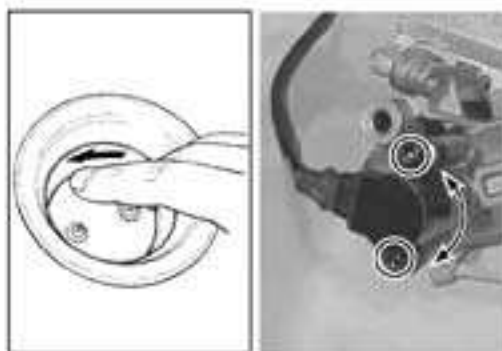

If the measured resistance is not within specification, adjust the STV adjuster (B) as follows:

- Under above condition, turn in or out the STV adjuster (B) until the resistance becomes specified value.

If the measured resistance is not obtain, replace the STP sensor with a new one, and adjust the STP sensor positioning again.

**NOTE:**

To adjust the TP sensor, install the throttle body assembly to the engine and after warming up engine. (☞ 4-64)

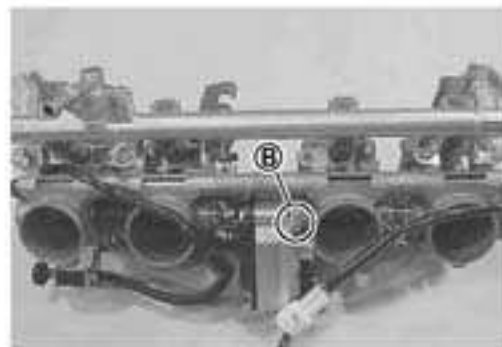

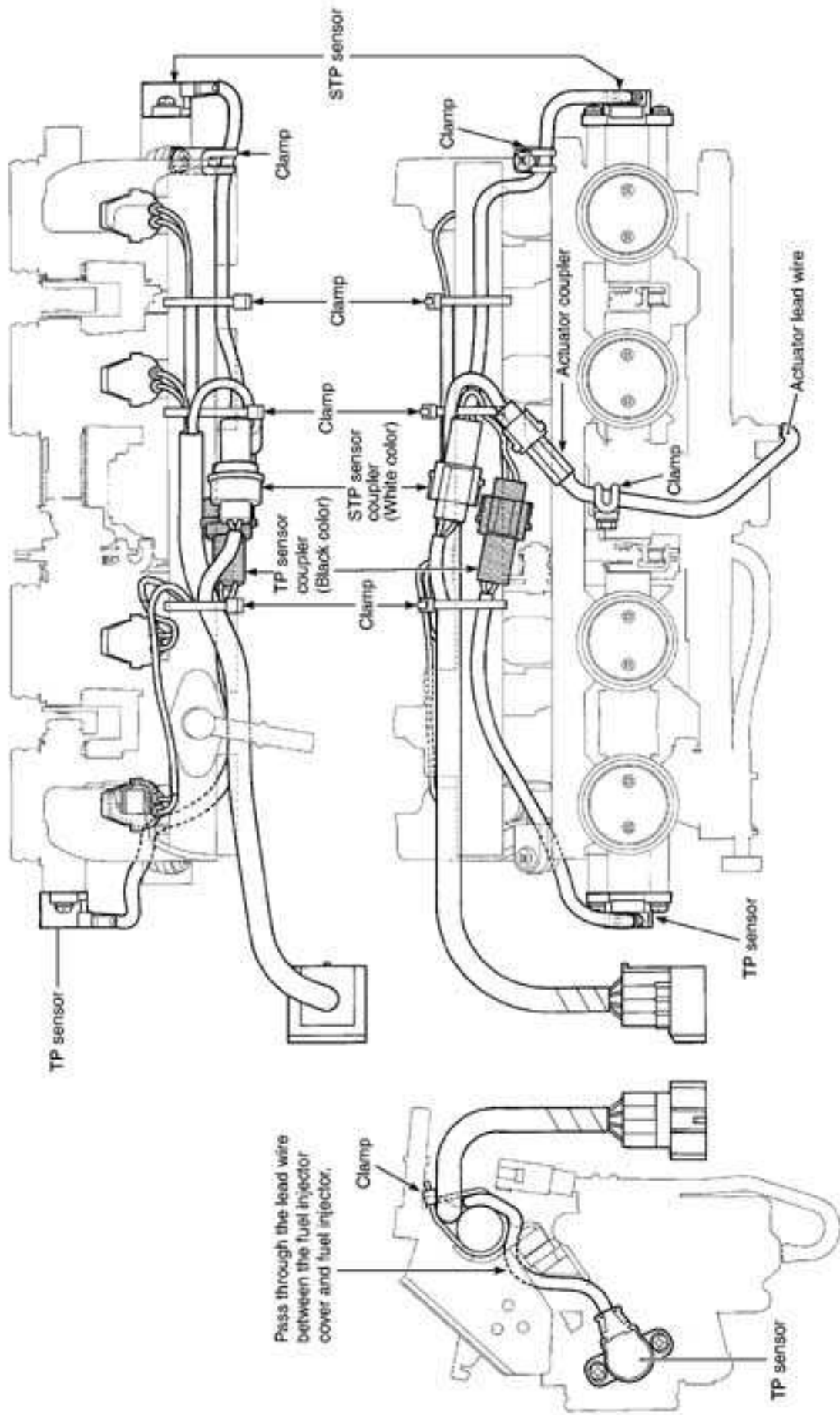



## THROTTLE BODY INSTALLATION

Installation is in the reverse order of removal. Pay attention to the following points:

- Connect the throttle pulling cable ① and throttle returning cable ② to the throttle cable drum.
- Adjust the throttle cable play with the cable adjusters ③ and ④.

Refer to page 2-15 for details.

## TP SENSOR ADJUSTMENT

- After checking or adjusting the throttle valve synchronization, measure the TP sensor resistance and adjust the TP sensor positioning as follows:
- After warming up engine, adjust the idling speed to  $1\ 100 \pm 100$  rpm.
- Stop the warmed-up engine and disconnect the TP sensor lead wire coupler. (☞ 4-35)
- Measure the resistance between yellow and black wires.

**DATA** TP sensor setting resistance: **Approx. 1.1 k $\Omega$**   
(+ Yellow – Black)

 09900-25008: Multi circuit tester

 Tester knob indication: Resistance ( $\Omega$ )

- Loosen the TP sensor mounting screws.
- Adjust the TP sensor until resistance is within specification and tighten the TP sensor mounting screws.

 09930-11960: Torx wrench

 TP sensor mounting screw: **3.5 N·m**  
(0.35 kgf·m, 2.5 lb-ft)

## FUEL INJECTOR INSPECTION

The fuel injector can be checked without removing it from the throttle body.

Refer to page 4-46 for details.

## FUEL INJECTOR REMOVAL

- Lift and support the fuel tank with a proper stay. (☞ 4-48)
- With battery negative cable disconnected, disconnect the injector couplers.
- Remove the fuel delivery pipe assembly. (☞ 4-56)
- Remove the fuel injectors No.1, No.2, No.3 and No.4. (☞ 4-57)

## INSPECTION

Check fuel injector filter for evidence of dirt and contamination. If present, clean and check for presence of dirt in the fuel lines and fuel tank.

## FUEL INJECTOR INSTALLATION

- Apply thin coat of the engine oil to new injector cushion seals and O-rings.
- Install the injector by pushing it straight to the throttle body. Never turn the injector while pushing it. (☞ 4-61)

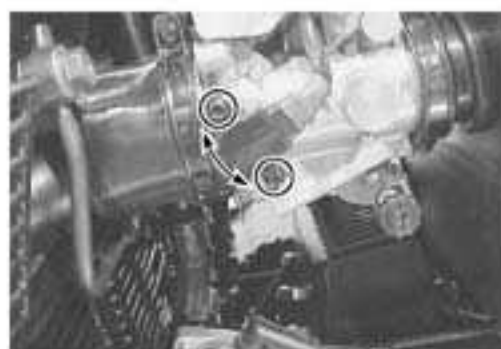
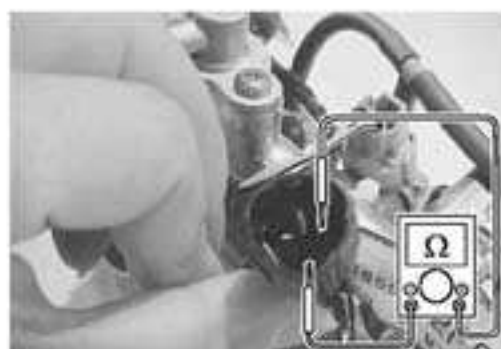
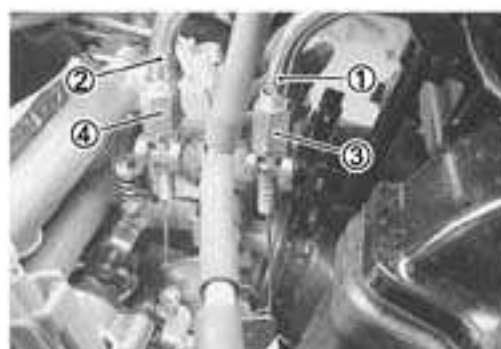



## FAST IDLE INSPECTION

The fast idle system is automatic type.

When the fast idle cam is turned by the secondary throttle valve actuator, the cam pushes the lever on the throttle valve shaft causing the throttle valve to open and raise the engine speed. When the engine has warmed up, depending on the oil temperature and lapsed time, the fast idle is cancelled allowing the engine to resume idle speed.

- \* Fast idle cancellation occurs in 30 seconds at the ambient temperature of 25°C.
- \* Fast idle cancellation occurs in 5 minutes at the ambient temperature of -10°C.

If, under the above conditions, the fast idle cannot be cancelled, the cause may possibly be short-circuit in oil temperature sensor or wiring harness.

### DATA Fast idle rpm

(Standard): 1 500 – 1 700 rpm/Cold engine

(Maximum) : 2 000 rpm/Cold engine

Idle rpm: 1 100 ± 100 rpm/Warmed engine

## FAST IDLE ADJUSTMENT

- Remove the fuel tank (☞4-48)
- Open the secondary throttle valve fully by turning its link with the finger. With the secondary throttle valve held at this position, measure the output voltage of TP sensor. (☞4-36)

DATA TP sensor output voltage: 1.195 V

TOOL 09900-25008: Multi circuit tester

Tester knob indication: Voltage (→)

If the voltage measured is out of specification, loosen the TP sensor screws and adjust the output voltage to specification.

### NOTE:

If fast idle fine adjustment is required or the screw (A) has been removed, the following adjustment will become necessary.

### ADJUSTMENT BY FAST IDLE SCREW

#### CAUTION

The fast idle screw is factory-adjusted at the time of delivery and therefore avoid removing or turning it unless otherwise necessary. Should the adjustment become necessary, perform the following procedures.

- Measure the voltage when the throttle valve is fully closed.

DATA TP sensor output voltage at full closed position: 1.12 V

If the voltage measured is out of specification, move the TP sensor to adjust the voltage to specification.

- Open the secondary throttle valve gradually and just when the STP sensor voltage has become 3.6 V, stop the valve opening and check for variation of the TP sensor output voltage.

DATA TP sensor output voltage variation: 0.035 V at STP sensor output voltage of 3.6 V

If the voltage variation is more than or less than 0.035 V, perform adjustment by the fast idle adjust screw (A).

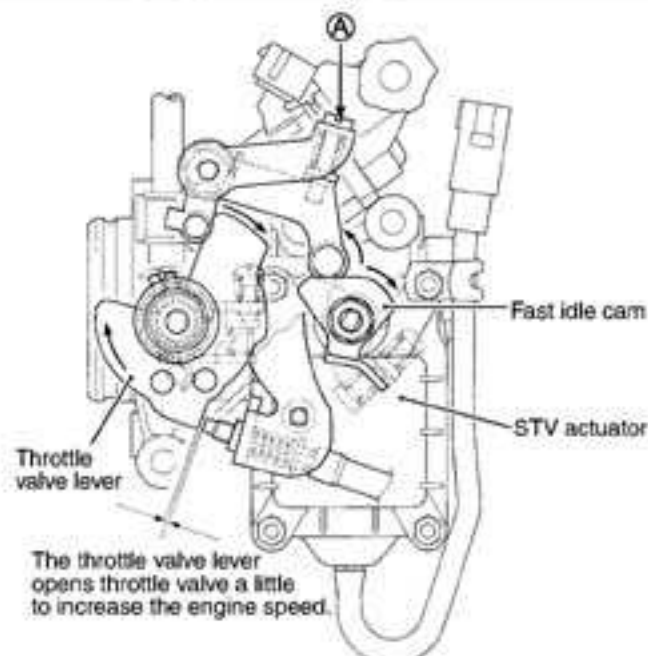

## THROTTLE VALVE SYNCHRONIZATION

Check and adjust the throttle valve synchronization among four cylinders. To synchronize throttle valves, disconnect the IAP sensor's vacuum hoses from the vacuum nipples on the respective throttle bodies and connect the vacuum balancer gauge hoses to each vacuum nipple.

 **09913-13121: Vacuum balancer gauge**

### NOTE:

*Before balancing the throttle valves, calibrate each vacuum balancer gauge.*



## THROTTLE VALVE SYNCHRONIZATION

- Lift and support the fuel tank. ( 4-48)
- Start up the engine and run it in idling condition for warming up.
- Stop the warmed-up engine.
- Disconnect the IAP sensor coupler ① and connect the vacuum balancer gauge hoses to the vacuum nipples respectively.
- Connect a tachometer and start up the engine.
- Bring the engine rpm to 1 100 rpm by the throttle stop screw.
- Check the vacuum of the four cylinders and balance the four throttle valves.

### NOTE:

- \* *During balancing the throttle valves, always set the engine rpm at 1 100 rpm, using throttle stop screw.*
- \* *After balancing the four valves, set the idle rpm to 1 100 rpm.*

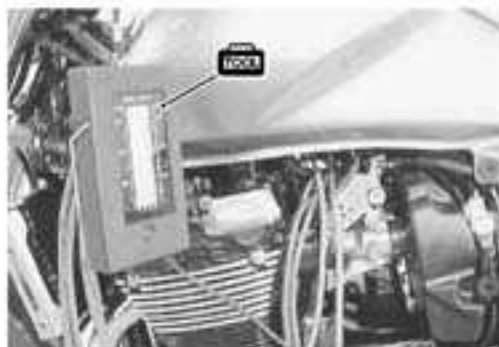

### For vacuum balancer gauge (09913-13121)

The vacuum gauge is positioned approx. 30° from the horizontal level, and in this position the four balls should be within one ball dia. If the difference is larger than one ball, turn the balance adjusting screw on the throttle body and bring the ball to the same level.

A correctly adjusted throttle valve synchronization has the balls in the No. 1 through 4 at the same level.



## THROTTLE CABLE ADJUSTMENT

### NOTE:

*Minor adjustment can be made by the throttle grip side adjuster.*  
( 2-15)

## SENSORS

### IAP SENSOR INSPECTION

The intake air pressure sensor is located at the upper frame between the tubes. (☞ 4-33)

### IAP SENSOR REMOVAL/INSTALLATION

- Lift and support the fuel tank. (☞ 4-48)
- Remove the IAP sensor ① and disconnect the coupler ② and vacuum hose ③.
- Installation is in the reverse order of removal.



### TP SENSOR INSPECTION

The throttle position sensor is installed on the No.1 throttle body. (☞ 4-35)

### TP SENSOR REMOVAL/INSTALLATION

- Lift and support the fuel tank. (☞ 4-48)
- Remove the TP sensor setting screws ① and disconnect its coupler.
- Install the TP sensor to the No.1 throttle body. Refer to page 4-64 for TP sensor setting procedure.



### STP SENSOR INSPECTION

The secondary throttle position sensor is installed on the No. 4 throttle body. (☞ 4-43)

### STP SENSOR REMOVAL/INSTALLATION

- Lift and support the fuel tank. (☞ 4-48)
- Remove the STP sensor setting screws ① and disconnect its coupler.
- Install the STP sensor to the No. 4 throttle body. Refer to page 4-62 for STP sensor setting procedure.

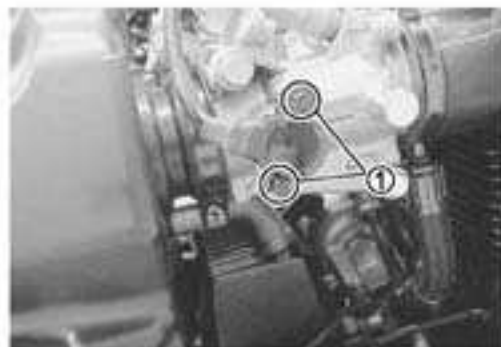

### CKP SENSOR INSPECTION

The signal rotor is mounted on the right end of the crankshaft, and the crankshaft position sensor (Pick-up coil) is installed on the right side of the crankcase. (☞ 4-32)

### CKP SENSOR REMOVAL/INSTALLATION

(☞ 3-15 and -69)



## CMP SENSOR INSPECTION

The signal rotor is installed on the intake camshaft, and the camshaft position sensor (Pick-up coil) is installed on the cylinder head cover. (☞ 4-31)

## CMP SENSOR REMOVAL/INSTALLATION

- Lift and support the fuel tank. (☞ 4-48)
- Disconnect the coupler and remove the CMP sensor. Installation is in the reverse order of removal. (☞ 3-23)



## IAT SENSOR INSPECTION

The intake air temperature sensor is installed at the right side of the air cleaner box. (☞ 4-38)

## IAT SENSOR REMOVAL/INSTALLATION

- Remove the right frame side cover. (☞ 6-3)
- Disconnect the IAT sensor coupler ① and remove the IAT sensor from the air cleaner box.
- Installation is in the reverse order of removal.

**Ⓜ** IAT sensor: 18 N·m (1.8 kgf·m, 13.0 lb-ft)



## EOT SENSOR INSPECTION

The engine oil temperature sensor is installed on the upper crankcase. (☞ 4-37 and 5-11)

## EOT SENSOR REMOVAL/INSTALLATION

(☞ 3-14)

## AP SENSOR INSPECTION

The atmospheric pressure sensor is located at the right side of the air cleaner box. (☞ 4-39)

## AP SENSOR REMOVAL/INSTALLATION

- Remove the right frame side cover. (☞ 6-3)
- Disconnect the coupler ① and remove the AP sensor.
- Installation is in the reverse order of removal.



## TO SENSOR INSPECTION

The tip over sensor is located in ahead of the battery holder. (☞ 4-41)

## TO SENSOR REMOVAL/INSTALLATION

- Remove the right frame side cover. (☞ 6-3)
- Remove the rear brake fluid reservoir bolt.
- Disconnect the coupler ① and remove the TO sensor.
- Installation is in the reverse order of removal.

### NOTE:

When installing the TO sensor, bring the "UPPER" letter on it to the top.





**OIL COOLING AND LUBRICATION SYSTEM****CONTENTS**

<b>OIL COOLING SYSTEM/LUBRICATION SYSTEM .....</b>	<b>5- 2</b>
<b>CYLINDER HEAD OIL COOLING CIRCUIT .....</b>	<b>5- 2</b>
<b>CYLINDER HEAD COOLING SYSTEM CHART .....</b>	<b>5- 3</b>
<b>ENGINE LUBRICATION CIRCUIT .....</b>	<b>5- 4</b>
<b>ENGINE LUBRICATION SYSTEM CHART .....</b>	<b>5- 6</b>
<b>OIL COOLER AND OIL HOSE .....</b>	<b>5- 7</b>
<b>OIL COOLER REMOVAL .....</b>	<b>5- 7</b>
<b>OIL COOLER INSPECTION AND CLEANING .....</b>	<b>5- 7</b>
<b>OIL HOSE/OIL PIPE INSPECTION.....</b>	<b>5- 8</b>
<b>OIL COOLER INSTALLATION .....</b>	<b>5- 8</b>
<b>COOLING FAN .....</b>	<b>5- 8</b>
<b>REMOVAL .....</b>	<b>5- 8</b>
<b>INSPECTION .....</b>	<b>5- 9</b>
<b>INSTALLATION.....</b>	<b>5- 9</b>
<b>COOLING FAN THERMO-SWITCH .....</b>	<b>5- 9</b>
<b>REMOVAL .....</b>	<b>5- 9</b>
<b>INSPECTION .....</b>	<b>5-10</b>
<b>INSTALLATION.....</b>	<b>5-10</b>
<b>OIL TEMPERATURE SENSOR.....</b>	<b>5-11</b>
<b>REMOVAL .....</b>	<b>5-11</b>
<b>INSPECTION .....</b>	<b>5-11</b>
<b>INSTALLATION.....</b>	<b>5-11</b>
<b>OIL PRESSURE .....</b>	<b>5-12</b>
<b>OIL FILTER.....</b>	<b>5-12</b>
<b>OIL STRAINER.....</b>	<b>5-12</b>
<b>OIL JET .....</b>	<b>5-12</b>
<b>OIL PUMP.....</b>	<b>5-12</b>
<b>OIL PRESSURE SWITCH.....</b>	<b>5-12</b>

# OIL COOLING SYSTEM/LUBRICATION SYSTEM

## CYLINDER HEAD OIL COOLING CIRCUIT

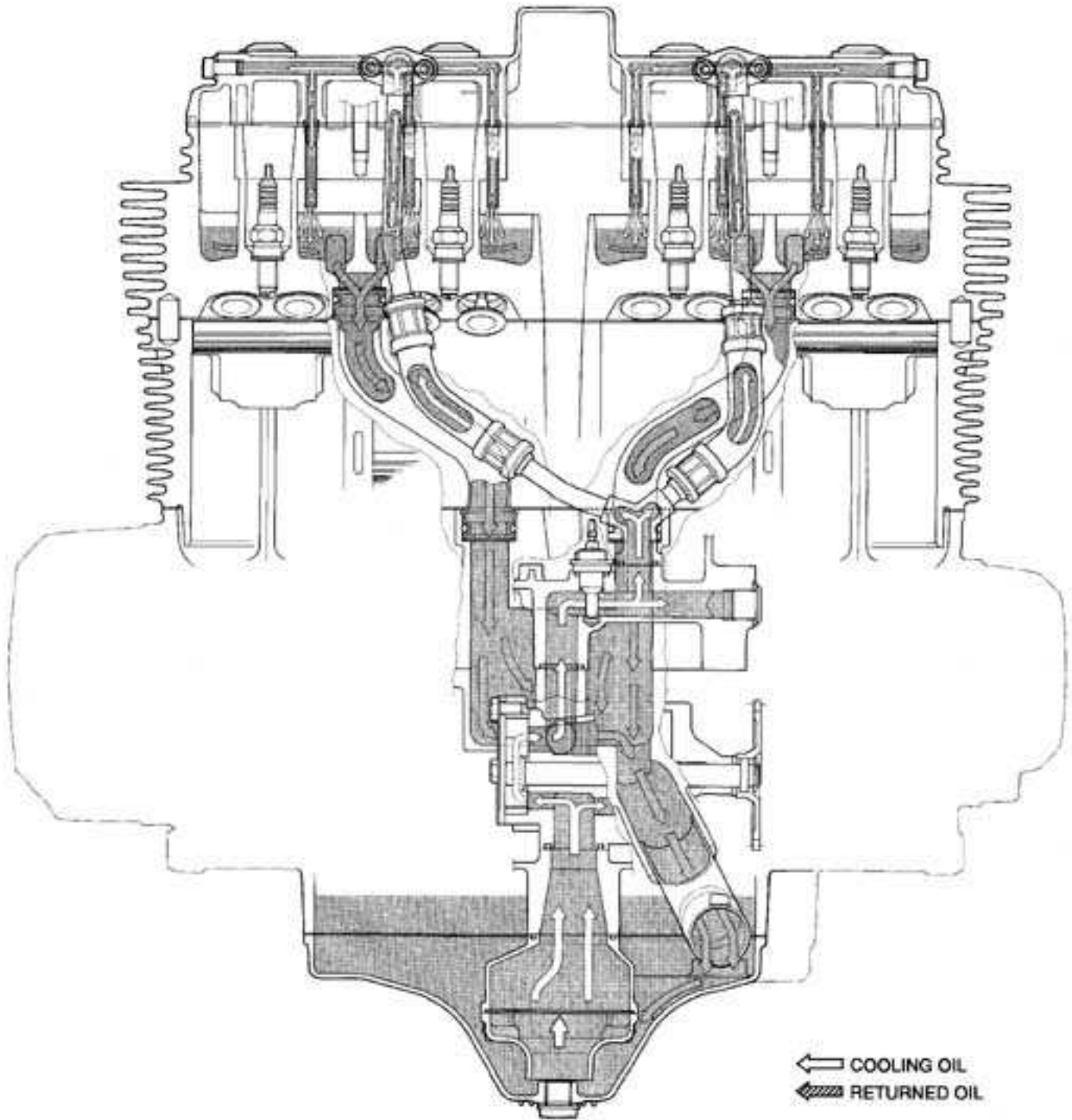



CYLINDER HEAD COOLING SYSTEM CHART

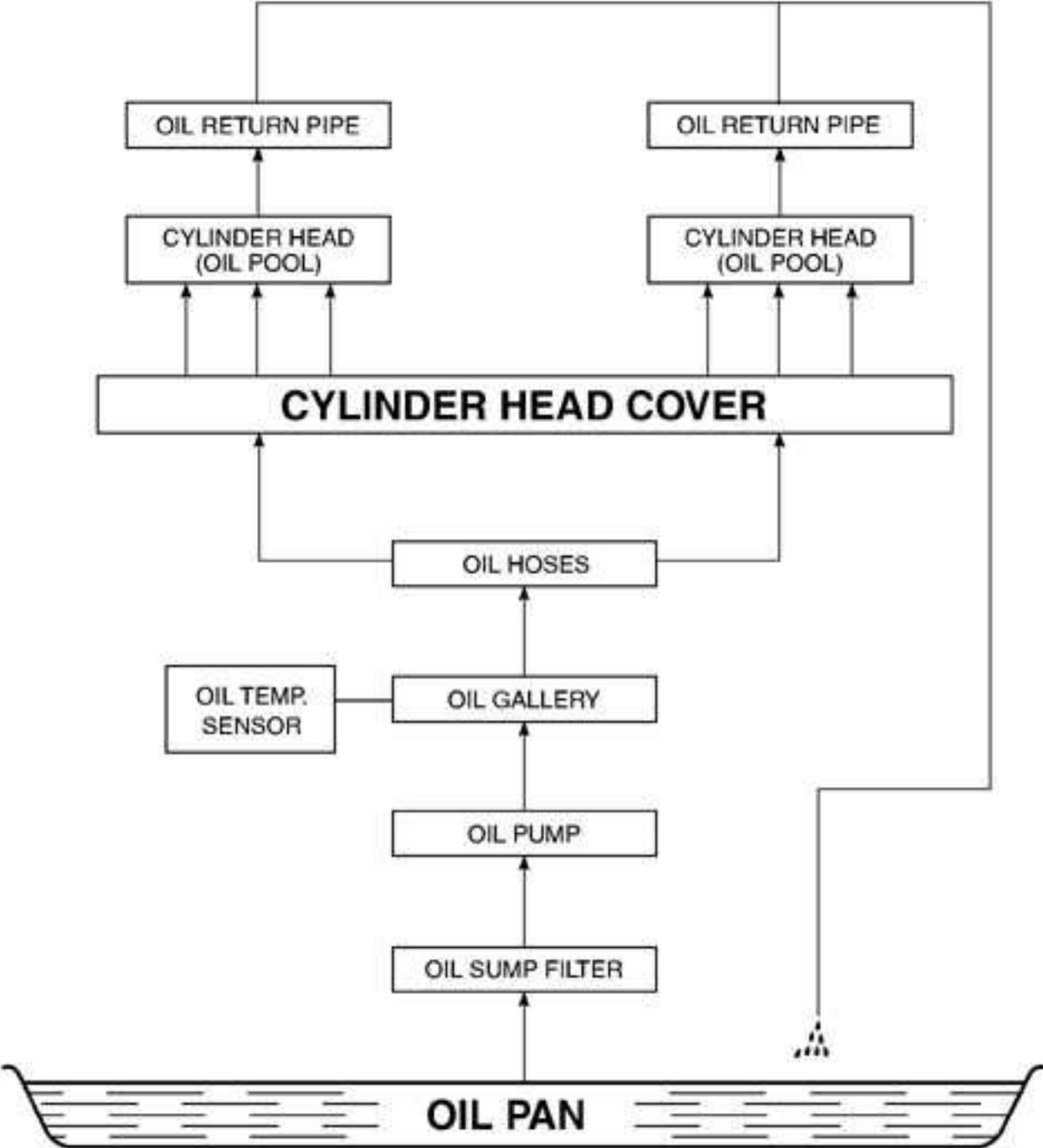

### ENGINE LUBRICATION CIRCUIT

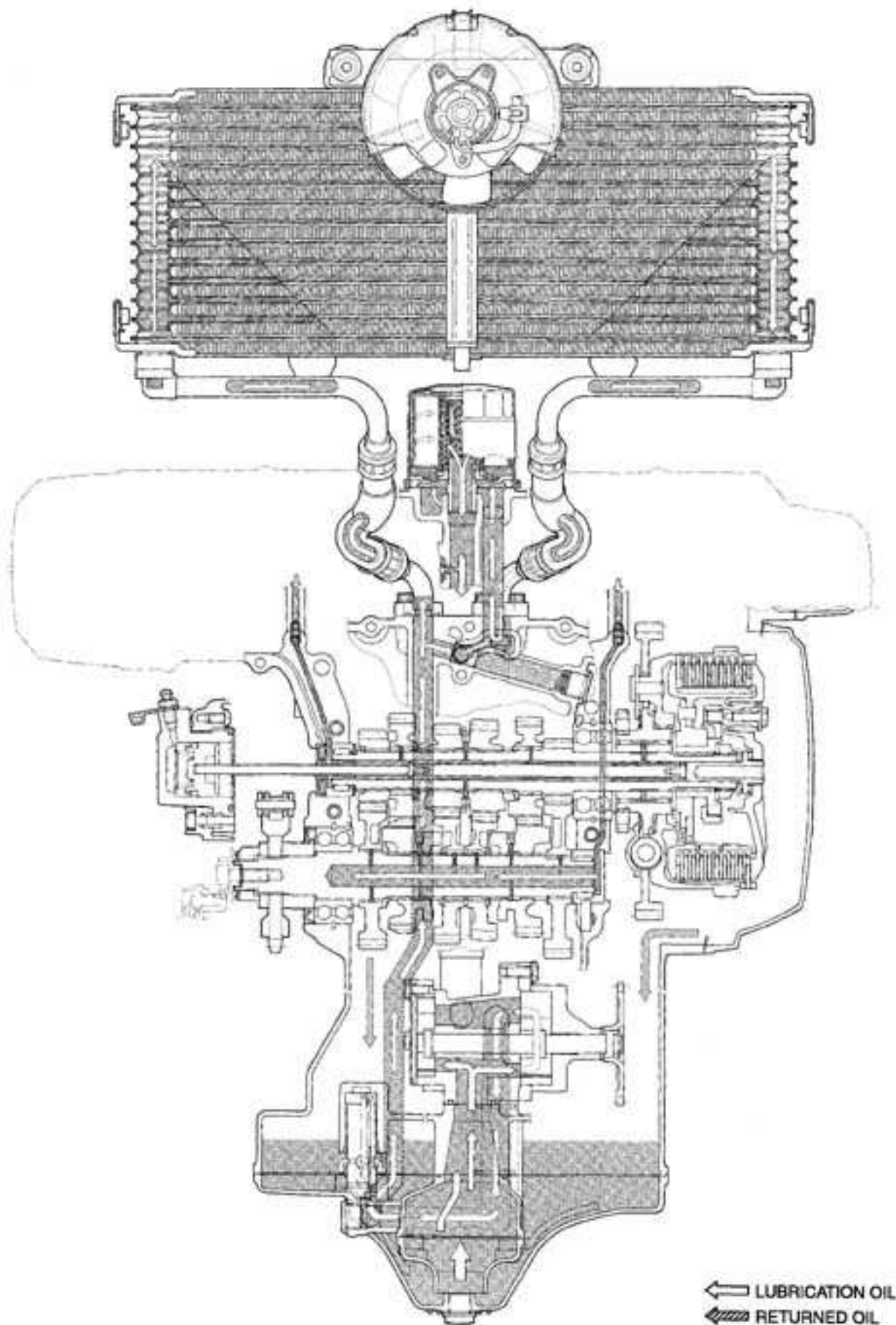

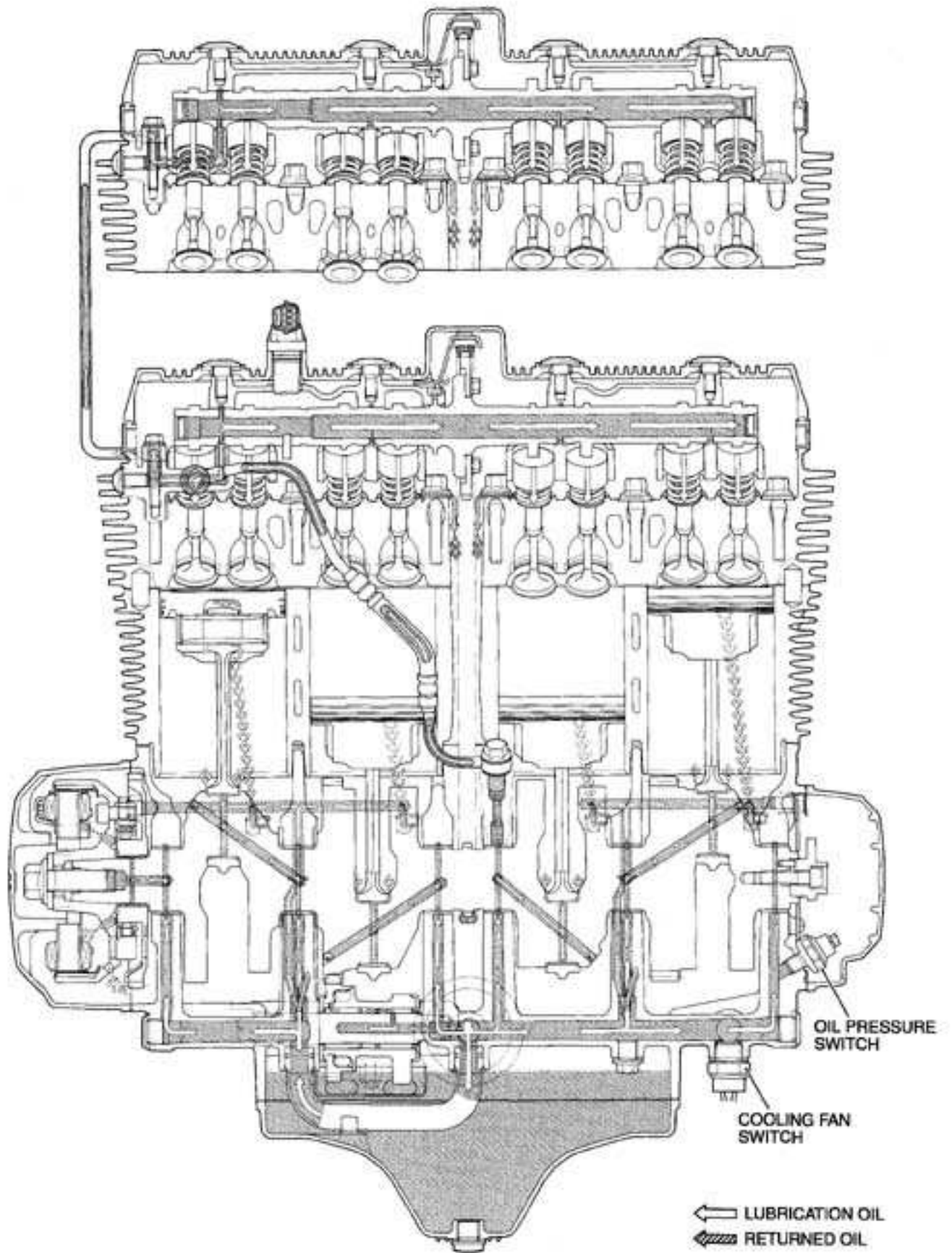

**ENGINE LUBRICATION SYSTEM CHART**

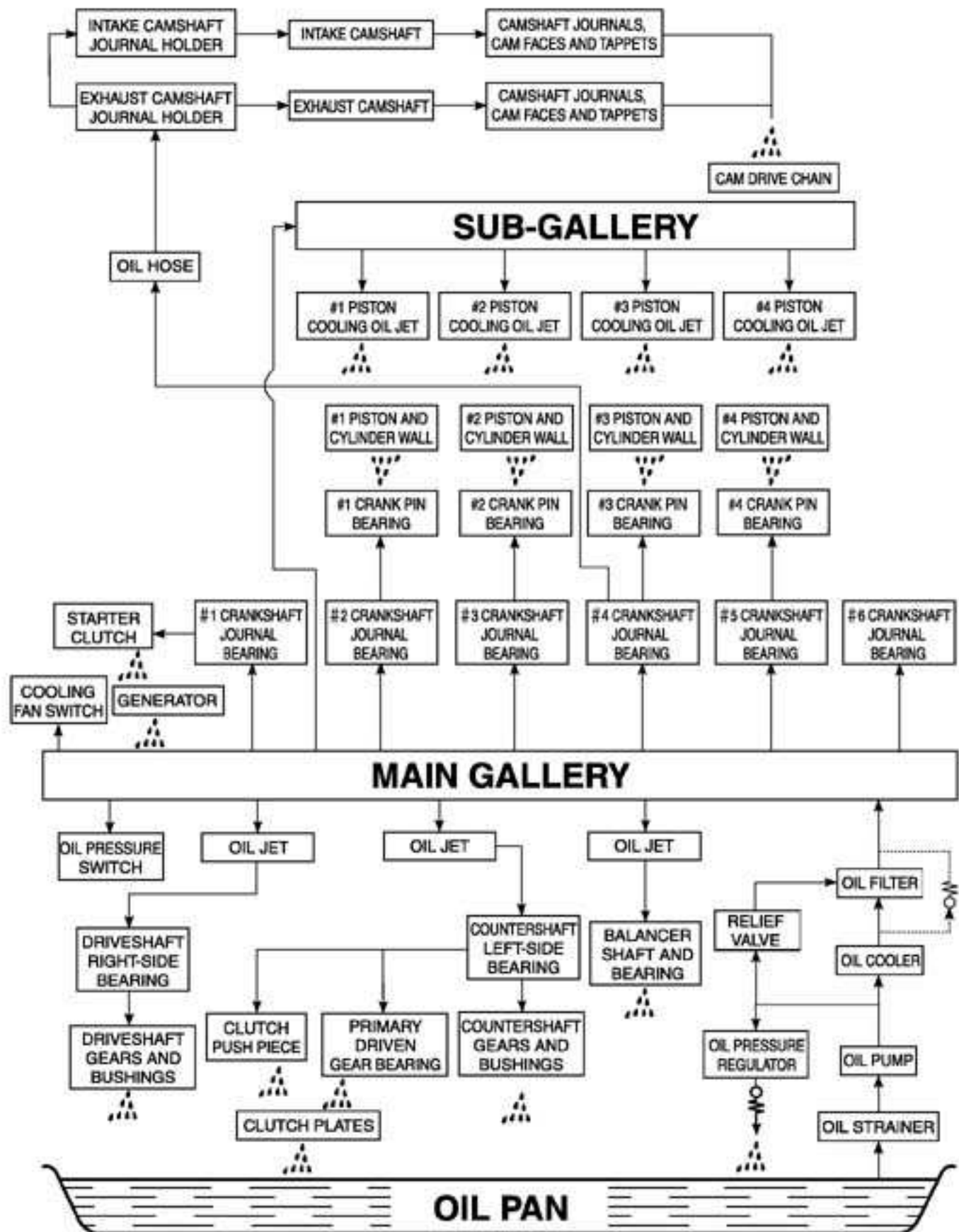

## OIL COOLER AND OIL HOSE

### OIL COOLER REMOVAL

- Drain engine oil. (☞ 2-13)



- Remove the oil cooler hoses.

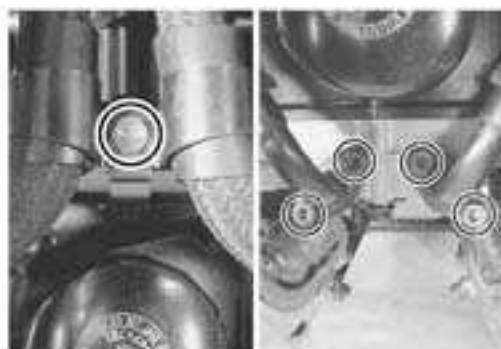

- Disconnect the cooling fan lead wire coupler.
- Remove the oil cooler.



### OIL COOLER INSPECTION AND CLEANING

- Inspect the oil cooler and hose joints for oil leakage. If any defects are found, replace the oil cooler and oil hoses with new ones.
- Road dirt or trash stuck to the fins must be removed.
- Use of compressed air is recommended for this cleaning.
- Fins bent down or dented can be repaired by straightening them with the blade of a small screwdriver.

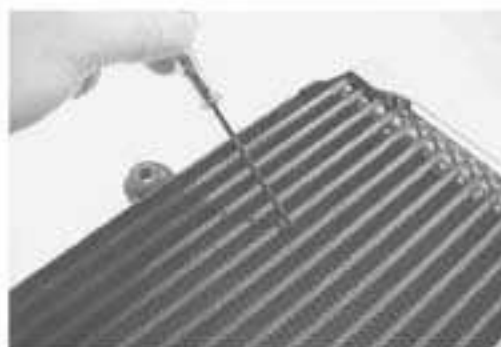
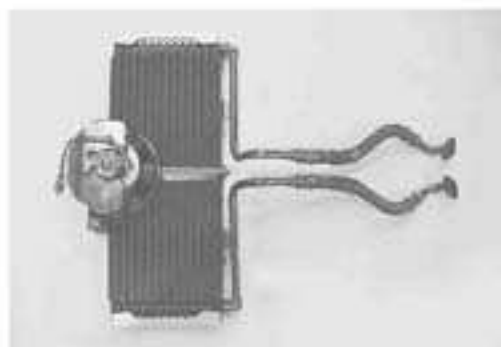

## OIL HOSE/OIL PIPE INSPECTION

- Any oil hose/oil pipe found in a cracked condition or flattened must be replaced.
- Any leakage from the connecting section should be corrected by proper tightening.

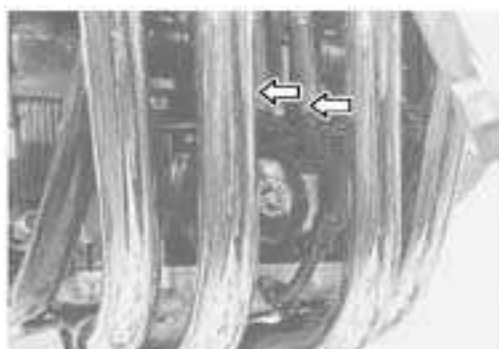

## OIL COOLER INSTALLATION

- Install the oil cooler.
- Use a new O-ring and install the oil hoses.

### CAUTION

Use a new O-ring to prevent engine oil leakage.

 99000-25010: SUZUKI SUPER GREASE "A"

### NOTE:

Apply grease "A" to the O-ring.



- Tighten the oil cooler hose bolts to the specified torque.

 Oil cooler hose bolt: 10 N·m (1.0 kgf·m, 7.3 lb-ft)

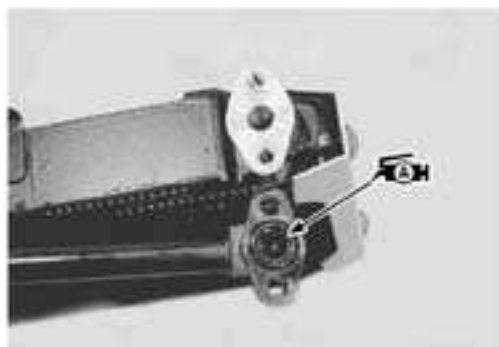
- Pour engine oil. ( 2-13)



## COOLING FAN REMOVAL

- Drain engine oil. ( 2-13)
- Remove the oil cooler. ( 5-7)
- Remove the cooling fan.





## INSPECTION

- Disconnect the cooling fan lead wire coupler.
- Test the cooling fan motor for load current with an ammeter connected as shown in the illustration.



- The voltmeter is for making sure that the battery applies 12 volts to the motor. With the motor with electric motor fan running at full speed, the ammeter should be indicating not more than 5 amperes.
- If the fan motor does not turn, replace the motor assembly with a new one.

### NOTE:

When making above test, it is not necessary to remove the cooling fan.

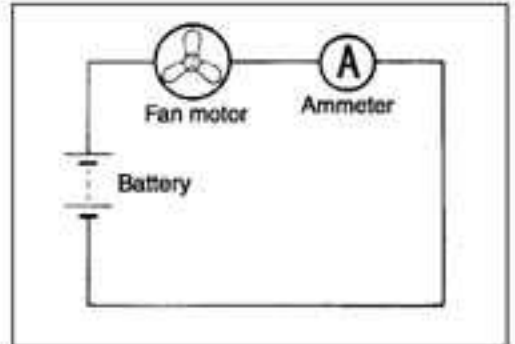

## INSTALLATION

- Install the cooling fan.
- Install the oil cooler. (☞ 5-8)
- Route the oil hoses.
- Pour engine oil. (☞ 2-13)

## COOLING FAN THERMO-SWITCH

### REMOVAL

- Drain engine oil. (☞ 2-13)
- Disconnect the cooling fan thermo-switch lead wire coupler.
- Remove the cooling fan thermo-switch.



## INSPECTION

- Check the thermo-switch closing or opening temperatures by testing it at the bench as shown in the figure. Connect the thermo-switch to a circuit tester and place it in the oil contained in a pan, which is placed on a stove.
- Heat the oil to raise its temperature slowly, and read the column thermometer when the switch closes or opens.

 09900-25008: Multi circuit tester set

 Tester knob indication: Continuity test (•||)

**DATA** Cooling fan thermo-switch operating temperature

Standard (OFF→ON): Approx. 120°C (248°F)

(ON→OFF): Approx. 108°C (226°F)

### CAUTION

- Take special care when handling the thermo-switch. It may cause damage if it gets a sharp impact.
- Do not contact the cooling fan thermo-switch ① and the column thermometer ② with a pan.

## INSTALLATION

- Install the new gasket washer ①.
- Tighten the cooling fan thermo-switch to the specified torque.

 Cooling fan thermo-switch: 17 N·m  
(1.7 kgf·m, 12.5 lb-ft)

- Pour engine oil. (☞2-13)

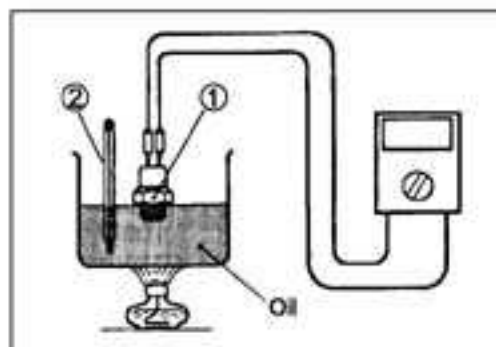

## OIL TEMPERATURE SENSOR

### REMOVAL

- Remove the right frame side cover. (☞6-3)
- Disconnect the oil temperature sensor lead wire coupler.
- Remove the oil temperature sensor.



### INSPECTION

- Check the oil temperature sensor by testing it at the bench as shown in the figure. Connect the temperature sensor ① to a circuit tester and place it in the oil contained in a pan, which is placed on a stove.
- Heat the oil to raise its temperature slowly and read the column thermometer ② and the ohmmeter.

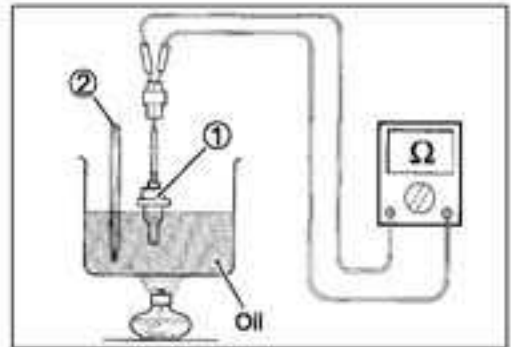

- If the temperature sensor ohmic value does not change in the proportion indicated, replace it with a new one.

#### DATA Temperature sensor specification

Temperature	Standard resistance
20°C ( 68°F)	Approx. 61.3 kΩ
50°C (122°F)	Approx. 17.8 kΩ
80°C (176°F)	Approx. 6.2 kΩ
100°C (212°F)	Approx. 3.4 kΩ
110°C (230°F)	Approx. 2.5 kΩ

If the resistance noted to show infinity or too much different resistance value, replace the temperature sensor with a new one.

#### CAUTION

- Take special care when handling the temperature-sensor. It may cause damage if it gets a sharp impact.
- Do not contact the oil temperature sensor ① and the column thermometer ② with a pan.

### INSTALLATION

- Install the new O-ring.
- Tighten the oil temperature sensor retainer to the specified torque.

 Oil temperature sensor: 10 N·m (1.0 kgf·m, 7.3 lb-ft)

#### CAUTION

Take special care when handling the temperature sensor. It may cause damage if it gets a sharp impact.

- Install the right frame side cover. (☞6-3)

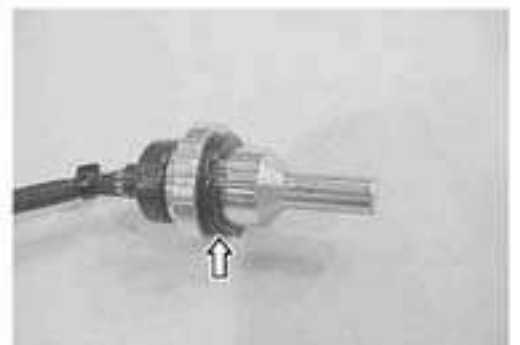

## OIL PRESSURE

(☞2-28)

## OIL FILTER

(☞2-13, 2-14)

## OIL STRAINER

(☞3-19, 3-62)

## OIL PRESSURE REGULATOR

(☞3-19)



## OIL JET

(☞3-54)



## OIL PUMP

(☞3-20, 3-56)

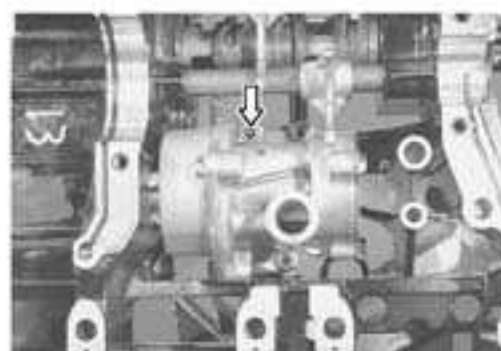

## OIL PRESSURE SWITCH

(☞3-15, 3-69, 7-25, 7-30)



# CHASSIS

## CONTENTS

<b>EXTERIOR PARTS</b> .....	6- 2
<b>CONSTRUCTION</b> .....	6- 2
<b>REMOVAL</b> .....	6- 3
<b>REMOUNTING</b> .....	6- 4
<b>FASTENER REMOVAL AND REINSTALLATION</b> .....	6- 5
<b>FRONT WHEEL</b> .....	6- 6
<b>CONSTRUCTION</b> .....	6- 6
<b>REMOVAL</b> .....	6- 7
<b>INSPECTION AND DISASSEMBLY</b> .....	6- 7
<b>REASSEMBLY AND REMOUNTING</b> .....	6- 9
<b>FRONT FORK</b> .....	6-12
<b>CONSTRUCTION</b> .....	6-12
<b>REMOVAL AND DISASSEMBLY</b> .....	6-13
<b>INSPECTION</b> .....	6-16
<b>REASSEMBLY AND REMOUNTING</b> .....	6-17
<b>SUSPENSION SETTING</b> .....	6-22
<b>STEERING AND HANDLEBARS</b> .....	6-23
<b>CONSTRUCTION</b> .....	6-23
<b>REMOVAL AND DISASSEMBLY</b> .....	6-24
<b>INSPECTION AND DISASSEMBLY</b> .....	6-27
<b>REASSEMBLY AND REMOUNTING</b> .....	6-28
<b>STEERING TENSION ADJUSTMENT</b> .....	6-31
<b>REAR WHEEL</b> .....	6-32
<b>CONSTRUCTION</b> .....	6-32
<b>REMOVAL</b> .....	6-33
<b>INSPECTION AND DISASSEMBLY</b> .....	6-34
<b>REASSEMBLY AND REMOUNTING</b> .....	6-36
<b>REAR SHOCK ABSORBER</b> .....	6-40
<b>CONSTRUCTION</b> .....	6-40
<b>REMOVAL</b> .....	6-41
<b>INSPECTION</b> .....	6-42
<b>REAR SHOCK ABSORBER SCRAPPING PROCEDURE</b> .....	6-42
<b>REMOUNTING</b> .....	6-42
<b>SUSPENSION SETTING</b> .....	6-43
<b>REAR SWINGARM</b> .....	6-44
<b>CONSTRUCTION</b> .....	6-44
<b>REMOVAL</b> .....	6-45
<b>INSPECTION AND DISASSEMBLY</b> .....	6-46
<b>REASSEMBLY</b> .....	6-47
<b>REMOUNTING</b> .....	6-48
<b>FINAL INSPECTION AND ADJUSTMENT</b> .....	6-48

<b>FRONT BRAKE</b> .....	6-49
<b>CONSTRUCTION</b> .....	6-49
<b>BRAKE PAD REPLACEMENT</b> .....	6-50
<b>BRAKE FLUID REPLACEMENT</b> .....	6-50
<b>CALIPER REMOVAL AND DISASSEMBLY</b> .....	6-51
<b>CALIPER INSPECTION</b> .....	6-52
<b>CALIPER REASSEMBLY AND REMOUNTING</b> .....	6-52
<b>BRAKE DISC INSPECTION</b> .....	6-53
<b>MASTER CYLINDER REMOVAL AND DISASSEMBLY</b> .....	6-54
<b>MASTER CYLINDER INSPECTION</b> .....	6-55
<b>MASTER CYLINDER REASSEMBLY AND REMOUNTING</b> .....	6-55
<b>REAR BRAKE</b> .....	6-57
<b>CONSTRUCTION</b> .....	6-57
<b>BRAKE PAD REPLACEMENT</b> .....	6-58
<b>BRAKE FLUID REPLACEMENT</b> .....	6-58
<b>CALIPER REMOVAL AND DISASSEMBLY</b> .....	6-59
<b>CALIPER INSPECTION</b> .....	6-60
<b>CALIPER REASSEMBLY AND REMOUNTING</b> .....	6-60
<b>MASTER CYLINDER REMOVAL AND DISASSEMBLY</b> .....	6-61
<b>MASTER CYLINDER INSPECTION</b> .....	6-62
<b>MASTER CYLINDER REASSEMBLY AND REMOUNTING</b> .....	6-62
<b>CLUTCH RELEASE CYLINDER AND MASTER CYLINDER</b> .....	6-64
<b>CONSTRUCTION</b> .....	6-64
<b>CLUTCH FLUID REPLACEMENT</b> .....	6-65
<b>CLUTCH RELEASE CYLINDER REMOVAL AND DISASSEMBLY</b> ..	6-65
<b>CLUTCH RELEASE CYLINDER INSPECTION</b> .....	6-66
<b>CLUTCH RELEASE CYLINDER REASSEMBLY AND</b> <b>REMOUNTING</b> .....	6-66
<b>CLUTCH MASTER CYLINDER REMOVAL AND DISASSEMBLY</b> ...	6-67
<b>CLUTCH MASTER CYLINDER INSPECTION</b> .....	6-68
<b>CLUTCH MASTER CYLINDER REASSEMBLY AND</b> <b>REMOUNTING</b> .....	6-69
<b>TIRE AND WHEEL</b> .....	6-70
<b>TIRE REMOVAL</b> .....	6-70
<b>INSPECTION</b> .....	6-70
<b>VALVE INSTALLATION</b> .....	6-71
<b>TIRE INSTALLATION</b> .....	6-71

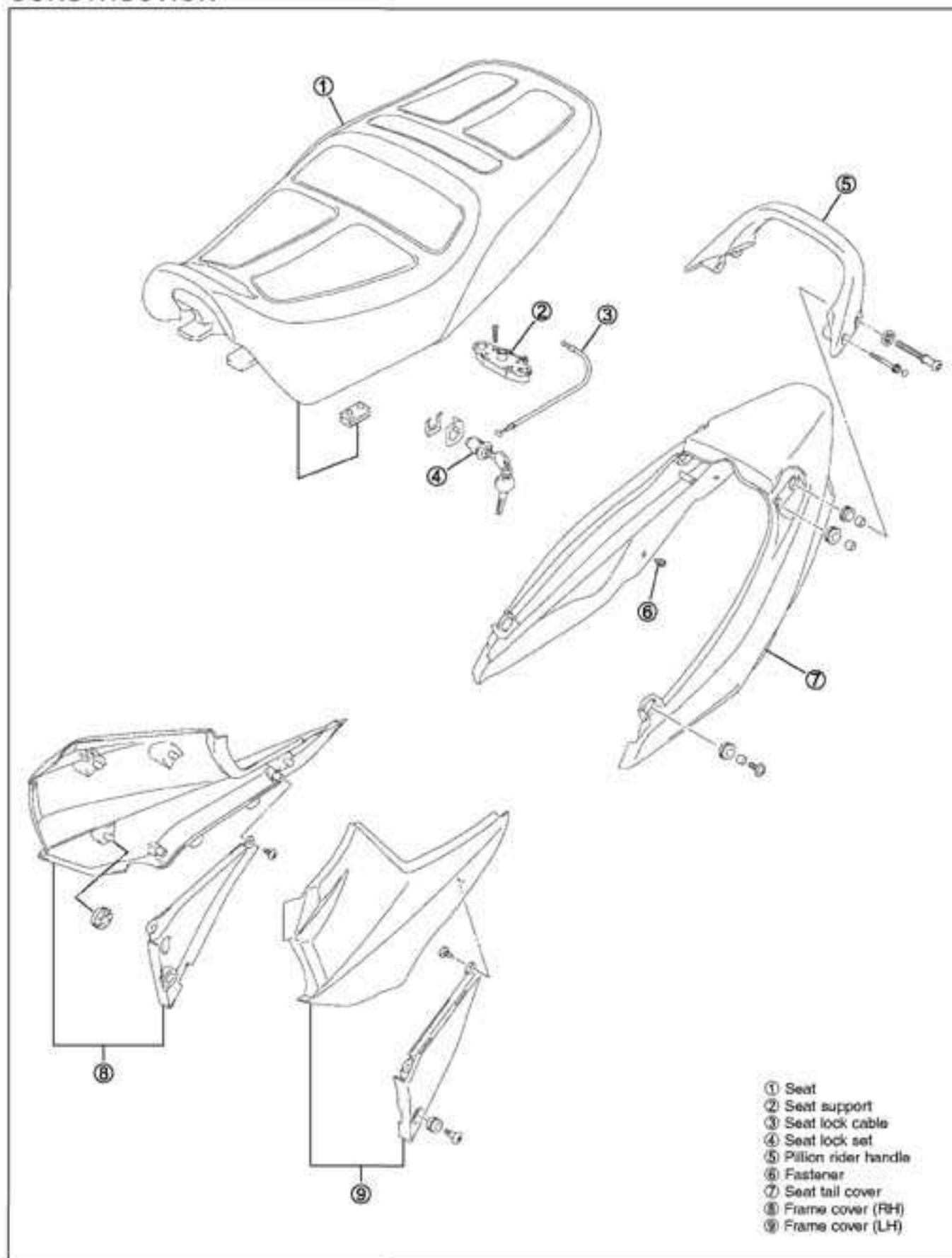

**EXTERIOR PARTS  
CONSTRUCTION**

## REMOVAL

### SEAT

- Remove the seat with the ignition key.



### FRAM COVERS

- Remove the seat. (☞ Above)
- Remove the frame cover mounting screws (left and right sides).
- Remove the frame covers by pulling on the hooked parts.

☆ : hooked part



### PILLION RIDER HANDLE

- Remove the pillion rider handle by removing the pillion rider handle mounting bolts.



### SEAT TAIL COVER

- Remove the seat. (☞ Above)
- Remove the pillion rider handle. (☞ Above)
- Remove the seat tail cover mounting screws.



- Remove the fasteners. (☞ 6-5)



- Disconnect the seat lock cable (A).



- Disconnect the brake light/taillight lead wire coupler.
- Remove the seat tail cover.



## REMountING

- Remount the seat, frame covers, pillion rider handle and seat tail cover in the reverse order of removal.

## FASTENER REMOVAL AND REINSTALLATION

### FASTENER

#### REMOVAL

- Depress the head of fasteners center piece ①.
- Pull out the fastener.

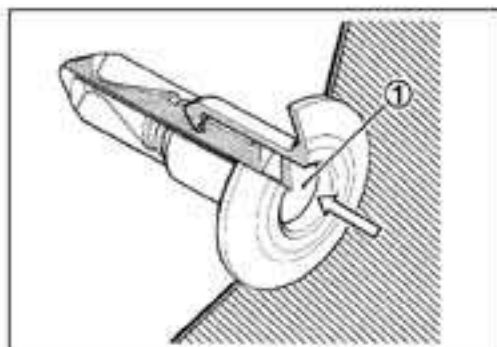

#### INSTALLATION

- Let the center piece stick out toward the head so that the pawls ② close.
- Insert the fastener into the installation hole.

#### NOTE:

*To prevent the pawl ② from damage, insert the fastener all the way into the installation hole.*

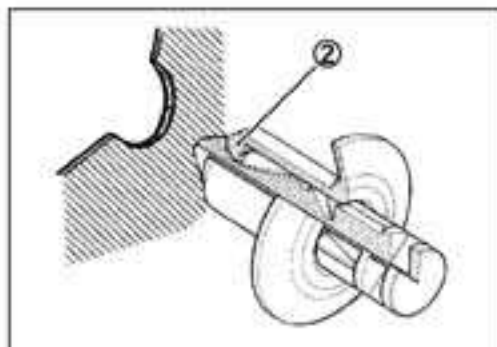

- Push in the head of center piece until it becomes flush with the fastener outside face.

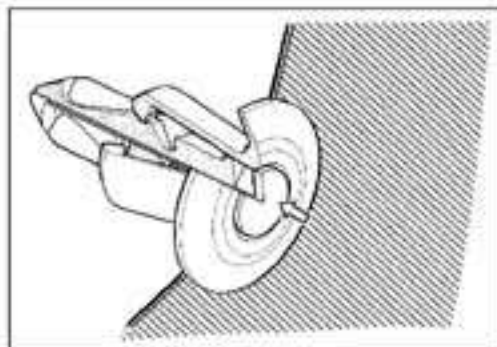

## FRONT WHEEL CONSTRUCTION

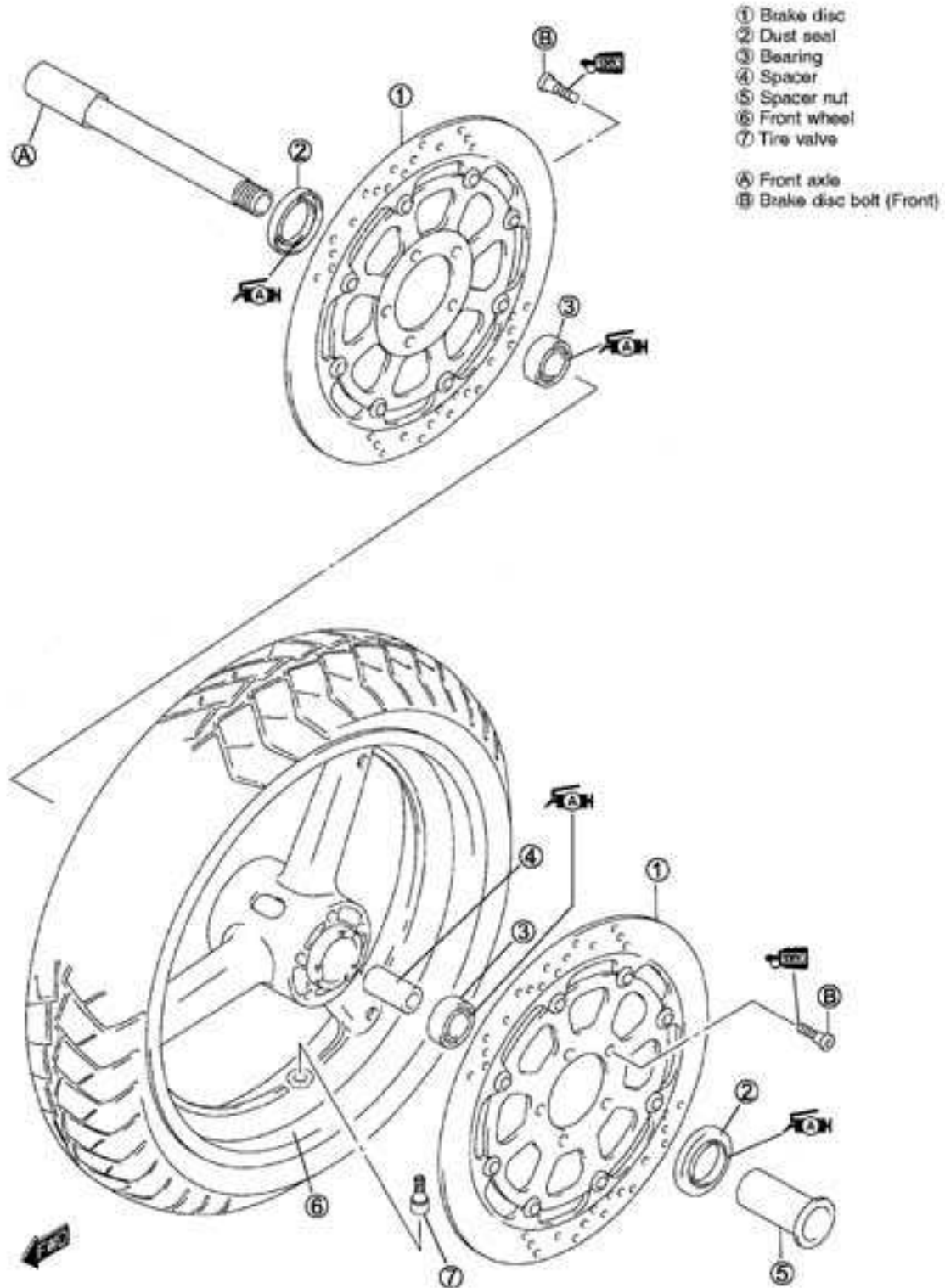

ITEM	N·m	kgf·m	lb·ft
Ⓐ	100	10.0	72.5
Ⓑ	23	2.3	16.5

## REMOVAL

- Remove the brake calipers ①.

### CAUTION

Do not operate the brake lever while removing the calipers.

- Loosen two axle pinch bolts ② on the right front fork leg.
- Loosen the front axle ③.

 09900-18740: Hexagon wrench 24 mm

- Raise the front wheel off the ground and support the motorcycle with a jack or a wooden block.

### CAUTION

Do not work by using side stand. Do not support the motorcycle with exhaust pipe. Make sure that the motorcycle is supported securely.

- Remove the front axle and the front wheel.

### NOTE:

After removing the front wheel, fit the calipers temporarily to the original positions.

- Loosen two axle pinch bolts on the left front fork leg and remove the spacer nut ④.



## INSPECTION AND DISASSEMBLY

### TIRE (☞ 6-70)

- Remove the brake disc.

### BRAKE DISC (☞ 6-53)





- Remove both dust seals by using the oil seal remover.

 09913-50121: Oil seal remover

#### CAUTION

Never reuse the removed dust seals.



#### FRONT AXLE

Using a dial gauge, check the front axle for runout and replace it if the runout exceeds the limit.

 09900-20607: Dial gauge (1/100)  
09900-20701: Magnetic stand  
09900-21304: V-block set (100 mm)

**DATA** Axle shaft runout  
Service Limit: 0.25 mm (0.010 in)

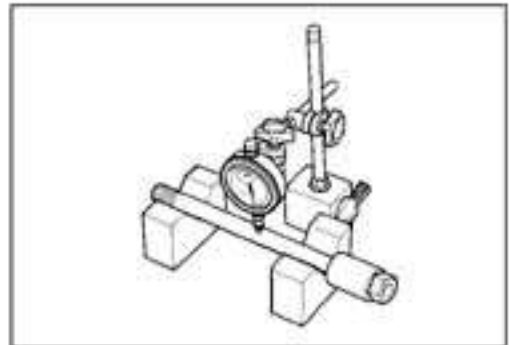

#### WHEEL

Make sure that the wheel runout checked as shown does not exceed the service limit. An excessive runout is usually due to worn or loosened wheel bearings and can be reduced by replacing the bearings. If bearing replacement fails to reduce the runout, replace the wheel.

(Wheel inspection:  6-70)

**DATA** Wheel runout  
Service Limit (Axial and Radial): 2.0 mm (0.08 in)

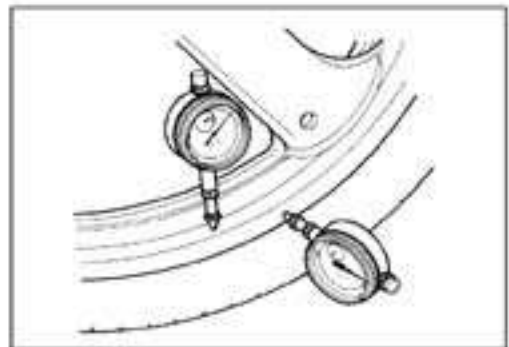

#### WHEEL BEARING

Inspect the play of the wheel bearings by finger while they are in the wheel. Rotate the inner race by finger to inspect for abnormal noise and smooth rotation.

Replace the bearing in the following procedure if there is anything unusual.

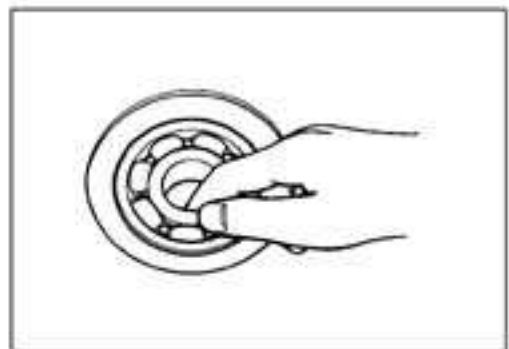

- Remove the wheel bearings by using the special tool.

 09921-20240: Bearing remover set

#### CAUTION

Never reuse the removed bearings.



## REASSEMBLY AND REMOUNTING

Reassemble and remount the front wheel in the reverse order of removal and disassembly. Pay attention to the following points:

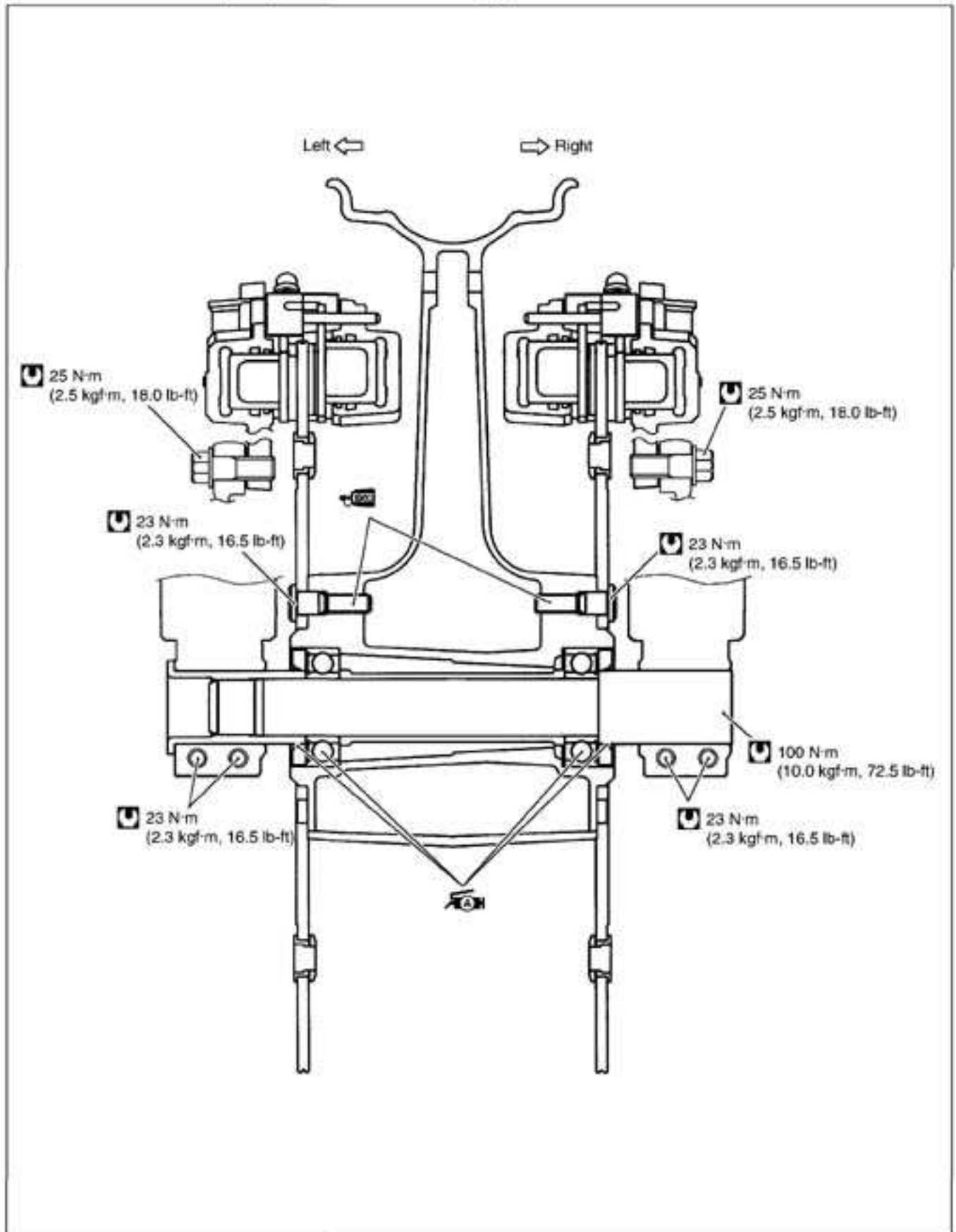

**WHEEL BEARING**

- Apply grease to the wheel bearings.

 99000-25010: SUZUKI SUPER GREASE "A"



- First install the left wheel bearing, then install the right wheel bearing and spacer by using the special tools.

 09941-34513: Bearing/Steering race installer set

**CAUTION**

The sealed cover of the bearing must face outside.

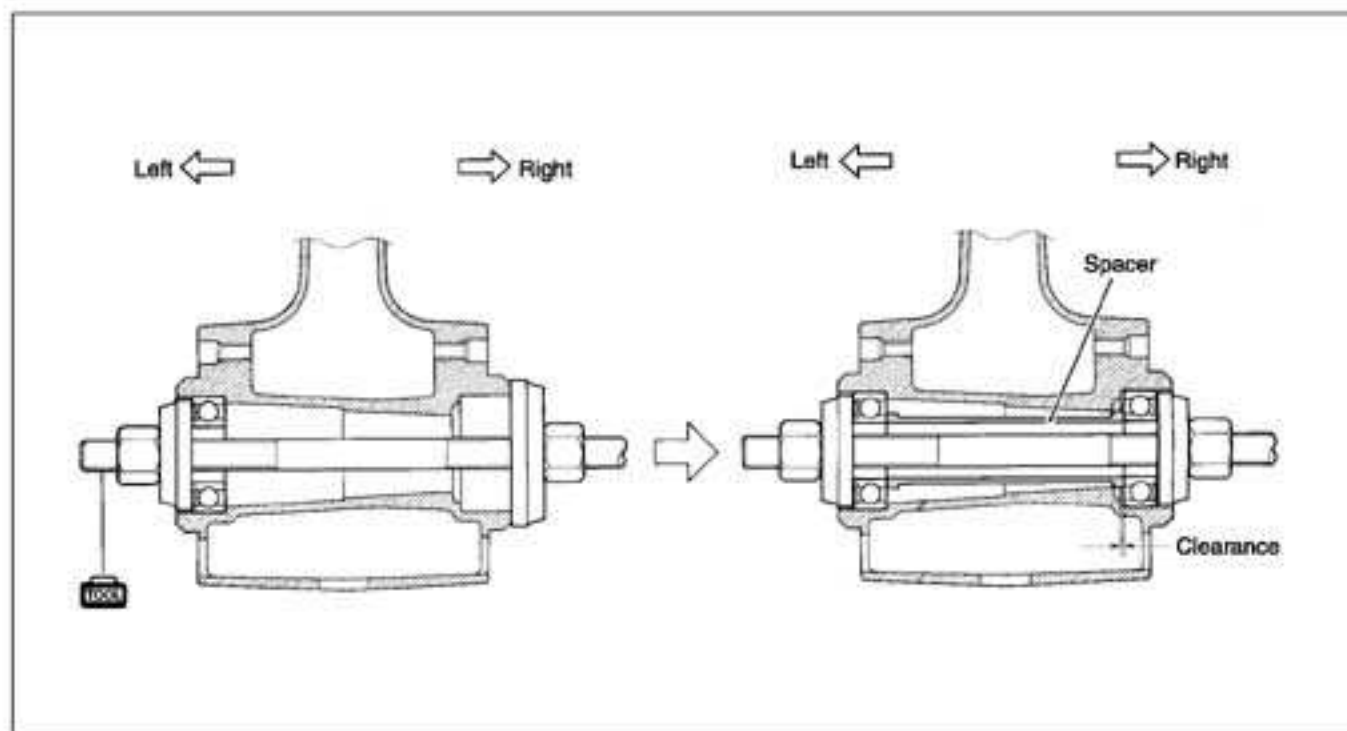
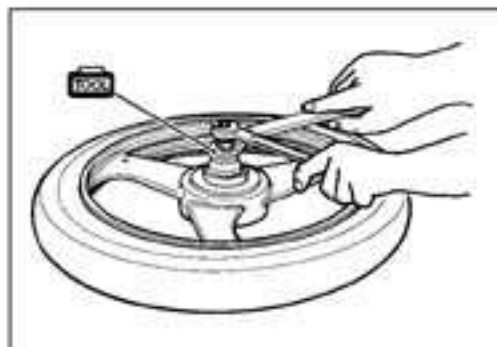
**BRAKE DISC**

Make sure that the brake disc is clean and free of any greasy matter.

- Apply THREAD LOCK SUPER "1360" to the disc mounting bolts and tighten them to the specified torque.

 Brake disc bolt (Front): 23 N·m (2.3 kgf·m, 16.5 lb-ft)

 99000-32130: THREAD LOCK SUPER "1360"



**SPACER NUT**

After touching the flange of spacer nut being contact with the left front fork leg, tighten the two axle pinch bolts on the left front fork leg to the specified torque.

 **Front axle pinch bolt: 23 N·m (2.3 kgf·m, 16.5 lb-ft)**

**WHEEL**

Install the front wheel with the front axle and hand-tighten the front axle temporarily.

**⚠ WARNING**

The directional arrow on the wheel should point to the wheel rotation, when remounting the wheel.

**BRAKE CALIPER**

• Tighten the brake caliper mounting bolts to the specified torque.

 **Front brake caliper mounting bolt: 25 N·m  
(2.5 kgf·m, 18.0 lb-ft)**

**NOTE:**

*Push the pistons all the way into the caliper and remount the calipers.*

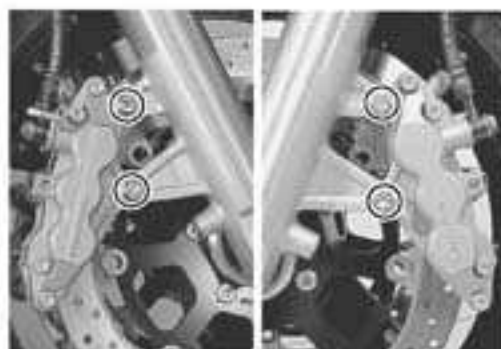
**FRONT AXLE**

• Tighten the front axle to the specified torque.

 **Front axle: 100 N·m (10.0 kgf·m, 72.5 lb-ft)**

**NOTE:**

*Before tightening the two axle pinch bolts on the right front fork leg, move the front fork up and down 4 or 5 times.*

• Tighten two axle pinch bolts on the right front fork leg to the specified torque.

 **Front axle pinch bolt: 23 N·m (2.3 kgf·m, 16.5 lb-ft)**



## FRONT FORK CONSTRUCTION

- ① O-ring  
 ② Washer  
 ③ Spacer  
 ④ Spring  
 ⑤ Inner rod/damper rod (cartridge)  
 ⑥ Inner tube  
 ⑦ Slide metal  
 ⑧ Protector  
 ⑨ Dust seal  
 ⑩ Oil seal stopper ring  
 ⑪ Oil seal  
 ⑫ Oil seal retainer  
 ⑬ Guide metal  
 ⑭ Oil lock piece  
 ⑮ Outer tube  
 ⑯ Gasket
- Ⓐ Front fork cap bolt  
 Ⓑ Inner rod lock nut  
 Ⓒ Front axle pinch bolt  
 Ⓓ Damper rod bolt

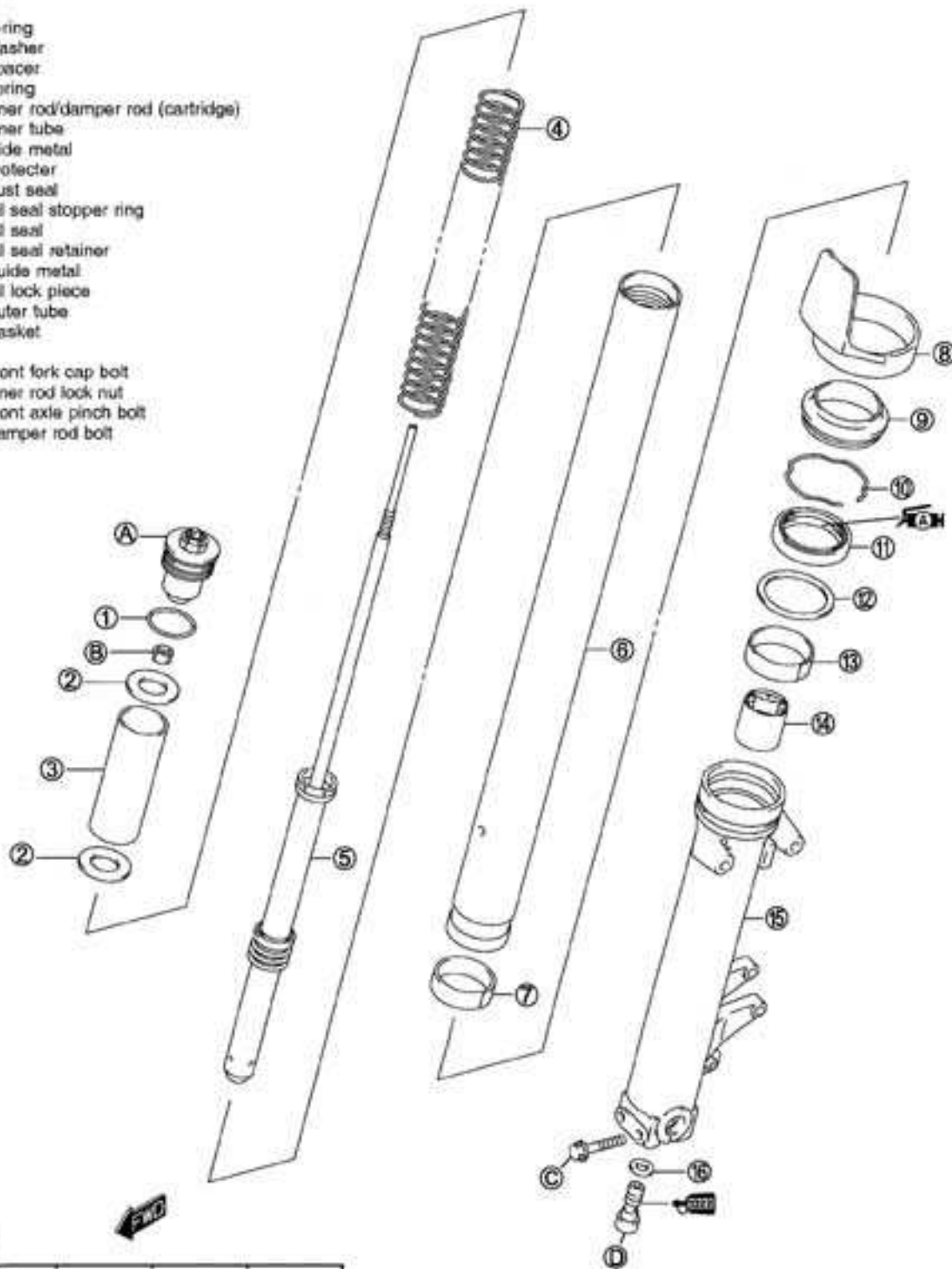

ITEM	N·m	kgf·m	lb·ft
Ⓐ	23	2.3	16.5
Ⓑ	15	1.5	11.0
Ⓒ	23	2.3	16.5
Ⓓ	40	4.0	29.0

## REMOVAL AND DISASSEMBLY

- Remove the front wheel. (☐ 6-7)
- Disconnect the brake hoses.
- Remove the front fender and brake hose guides.



- Loosen the front fork upper clamp bolts ①.

**NOTE:**

*Slightly loosen the front fork cap bolts ② before loosening the lower clamp bolts to facilitate later disassembly.*



- Loosen the front fork lower clamp bolts.

**NOTE:**

*Hold the front fork by the hand to prevent sliding out of the steering stem.*



- Remove the protector ③.





- Loosen and remove the front fork cap bolt.



- Remove the spacer ①, washers ② and spring ③.

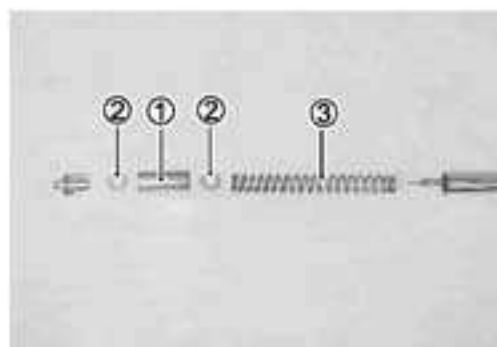

- Remove the adjuster rod.



- Invert the fork and drain the fork oil out of the fork by stroking.
- Hold the fork inverted for a few minutes to drain oil.



- Remove the dust seal.



- Remove the oil seal stopper ring.



- Remove the front axle pinch bolts.



- Remove the damper rod with the front fork assembling tool.

 09940-30250: Front fork assembling tool.

**CAUTION**

Do not disassemble the inner rod/damper rod (cartridge).

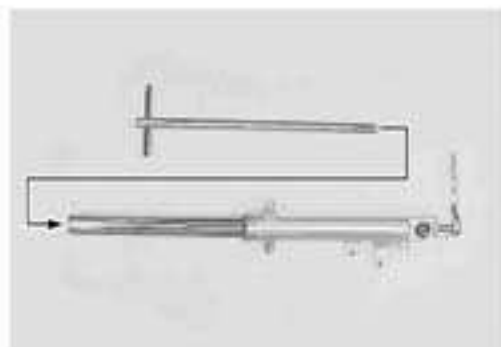

- Drain the fork oil out of inner rod / damper rod (cartridge) by pumping the rod.

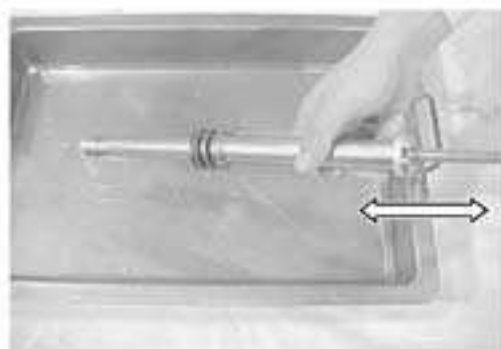

- Pull the inner tube out of the outer tube.

**NOTE:**

*Be careful not to damage the inner tube.*

**CAUTION**

The slide metals, oil seal and dust seal must be replaced with the new ones when reassembling the front fork.



- Remove the following parts.
  - Oil seal
  - Oil seal retainer
  - Guide metal
  - Slide metal
  - Oil lock piece

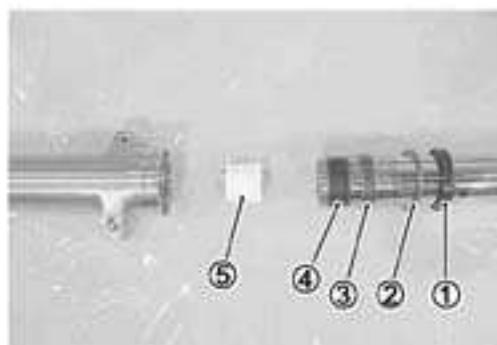

## INSPECTION

### INNER AND OUTER TUBES

- Inspect the inner tube outer surface and the outer tube inner surface for scratches.
- If any defects are found, replace them with the new ones.



### FORK SPRING

- Measure the fork spring free length.
- If it is shorter than the service limit, replace it with a new one.

**DATA** Front fork spring free length  
Service limit : 316.0 mm (12.44 in)

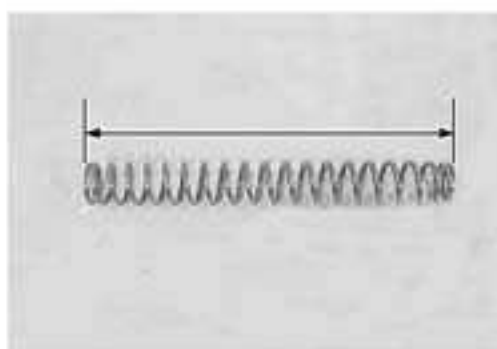

### DAMPER ROD

- Move the inner rod by hand to examine it for smoothness.
- If any defects are found, replace the inner/damper rod (cartridge).



## REASSEMBLY AND REMOUNTING

Reassemble and remount the front fork in the reverse order of removal and disassembly. Pay attention to the following points:

### TUBE METALS AND SEALS

- Hold the inner tube vertically and clean the metal groove and install the guide metal ① by hand as shown.

#### CAUTION

Use special care to prevent damage to the "Teflon" coated surface of the guide metal when mounting it.

- Install the oil lock piece ① into the inner tube.



- Apply fork oil to the oil seal lip lightly before installing it.
- Assemble the following parts as shown.
  - ① Oil seal
  - ② Oil seal retainer
  - ③ Guide metal
  - ④ Dust seal
  - ⑤ Oil seal stopper ring

#### CAUTION

- When installing the oil seal to outer tube, be careful not to damage the oil seal lip.
- Do not use solvents for washing to prevent oil seal damage.
- Apply fork oil to the Anti-friction metals and lip of the oil seal.
- Make sure that the oil seal stopper ring ⑤ has been fitted securely.

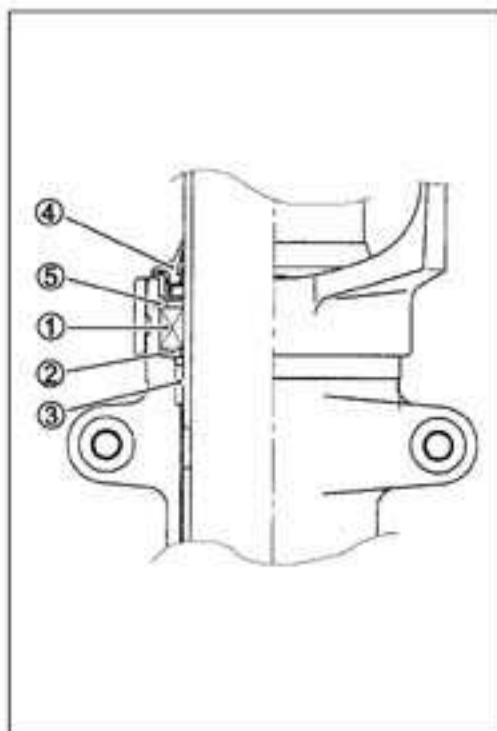

- Insert the inner tube into the outer tube and fit the oil seal and dust seal with the special tool.

 09940-52861: Front fork oil seal installer

#### NOTE:

Stamped mark on the oil seal should face outside.

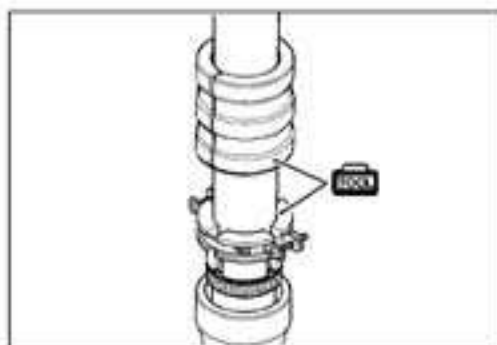

**DAMPER ROD BOLT**

- Insert the inner rod/damper rod (cartridge) into the inner tube.
- Apply **THREAD LOCK SUPER "1322"** to the damper rod bolt and tighten it to the specified torque with the special tool.

 **99000-32110: THREAD LOCK SUPER "1322"**

 **09940-30250: Front fork assembling tool**

 **Damper rod bolt: 40 N·m (4.0 kgf·m, 29.0 lb-ft)**

**CAUTION**

Use a new damper rod bolt gasket to prevent oil leakage.

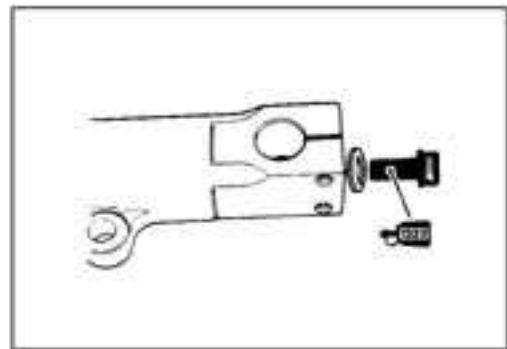
**FORK OIL**

- Place the front fork vertically without spring.
- Compress it fully.
- Pour the specified front fork oil into the front fork up to the top of the inner rod.

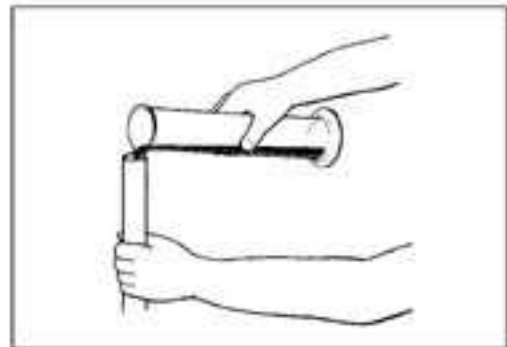

- Move the inner rod slowly more than ten times until no more air bubbles come out from the oil.

 **09940-52841: Inner rod holder**

**NOTE:**

Refill the front fork oil up to the top of the outer tube to find air bubbles while bleeding air.

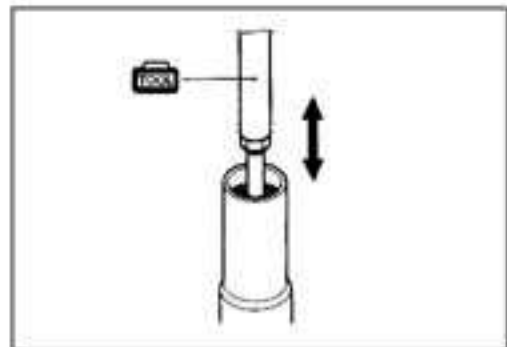

- Move the inner tube up and down several strokes until no more bubbles come out from the oil.
- Keep the front fork vertically and leave it during 5 – 6 minutes.

**NOTE:**

- \* Always keep the oil level over the cartridge top end, or air may enter the cartridge during this procedure.
- \* Take extreme attention to pump out air completely.

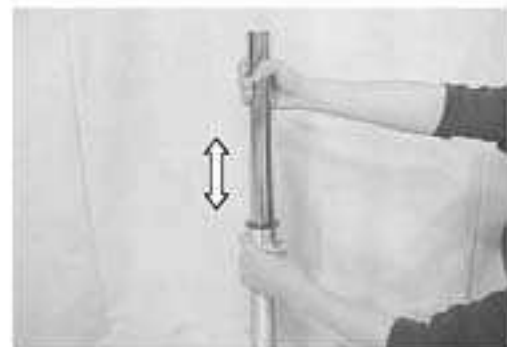

- Install the adjusting rod ①.

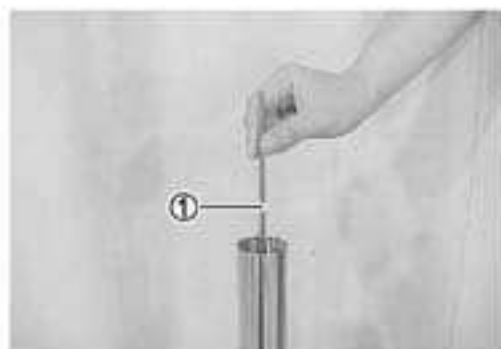

- Hold the front fork vertically and adjust the fork oil level with the special tool.

**NOTE:**

*When adjusting the fork oil level, remove the fork spring and compress the inner tube fully.*

 09943-74111: Front fork oil level gauge

Fork oil level: 108.0 mm (4.25 in)

 99000-99044-L01: SUZUKI FORK OIL L01

Capacity (each leg): 644.0 ml (21.76/22.68 US/Imp oz)

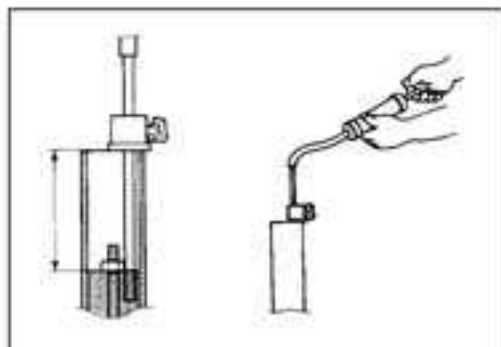

### FORK SPRING

- Pull the inner rod up with the inner rod holder.

 09940-52841: Inner rod holder



- Install the fork spring.

**NOTE:**

*The small end of the fork spring should be at the bottom of the front fork.*

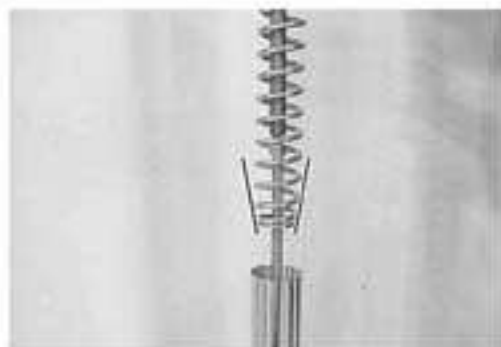



**FRONT FORK CAP BOLT**

- Install the washers ① and spacer ②.

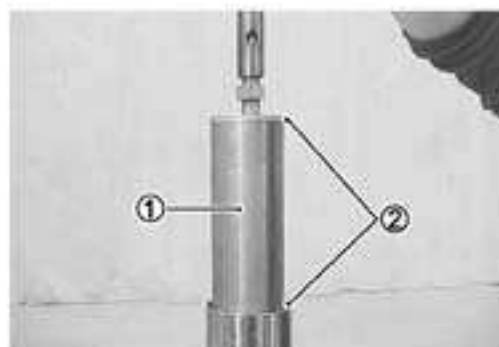

- Adjust the height (A) of the inner rod threads by turning the lock nut (3) as shown.

(A): 11 mm (0.43 in)

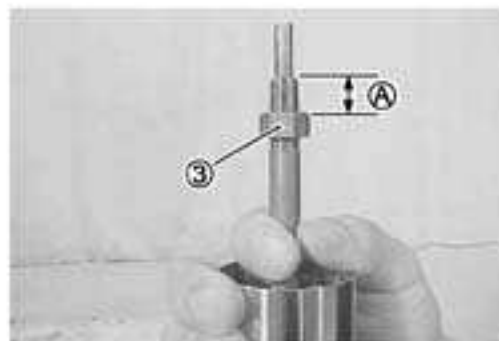

- Tighten the front fork cap bolt to seat at lock nut by hand tightening.
- Hold the front fork cap bolt, tighten the lock nut.

**Inner rod lock nut : 15 N·m (1.5 kgf·m, 1b-ft)**



- Apply fork oil lightly to the O-ring.

**CAUTION**

**Use a new O-ring to prevent oil leakage.**

- Tighten the front fork cap bolt temporarily.



- Install the front fork protector.

**NOTE:**

*Fit the projection of the front fork protector to the depression of the front fork outer tube.*



- Fix the front fork to the front fork lower bracket temporarily as shown.
- Tighten the front fork cap bolt to the specified torque.

 **Front fork cap bolt: 23 N·m (2.3 kgf·m, 16.5 lb-ft)**



- Align the top of the inner tube to the upper surface of the steering stem upper bracket.



- Tighten the front fork upper and lower clamp bolts.

 **Front fork upper clamp bolt: 23 N·m (2.3 kgf·m, 16.5 lb-ft)**

**Front fork lower clamp bolt: 23 N·m (2.3 kgf·m, 16.5 lb-ft)**



- Install the front fender and brake hose guides.
- Install the front wheel. (☞ 6-9)
- Install the front brake calipers. (☞ 6-52)

**NOTE:**

*After install the brake calipers, front brake should be efficient by pumping the front brake lever.*



## SUSPENSION SETTING

After installing the front fork, adjust the spring pre-load and damping force as follows.

### SPRING PRE-LOAD ADJUSTMENT

There are eight grooves on the spring adjuster. Position 1 provides the maximum spring pre-load and position 8 provides the minimum spring pre-load.

**STD position: 5**

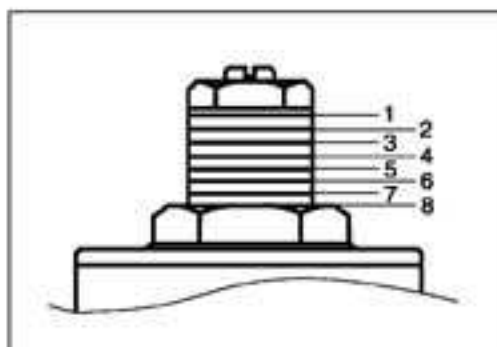

### DAMPING FORCE ADJUSTMENT

#### Rebound damping force

Fully turn the damping force adjuster ① clockwise. It is at stiffest position and turn it out to standard setting position.

**STD position: 8 clicks out from stiffest position**

#### Compression damping force

Fully turn the damping force adjuster ② clockwise. It is at stiffest position and turn it out to standard setting position.

**STD position: 7 clicks out from stiffest position**

#### NOTE:

Make sure to check the 1st click position by last click sound when turning in the adjuster.

#### ⚠ WARNING

Unequal suspension adjustment can cause poor handling and loss of stability. Adjust the right and left front forks to the same settings.

#### CAUTION

Do not turn the adjust screws more than the given position or the adjuster may be damaged.



Rebound side



Compression side

## STEERING AND HANDLEBAR CONSTRUCTION

- ① Handlebars
- ② Steering stem upper bracket
- ③ Dust seal
- ④ Bearing upper
- ⑤ Bearing lower
- ⑥ Steering stem lower bracket
- ⑦ Headlight housing bracket
- ⑧ Headlight housing stay

- Ⓐ Handlebar clamp bolt
- Ⓑ Steering stem head nut
- Ⓒ Handlebar holder nut
- Ⓓ Front fork upper clamp bolt
- Ⓔ Steering stem nut
- Ⓕ Front fork lower clamp bolt

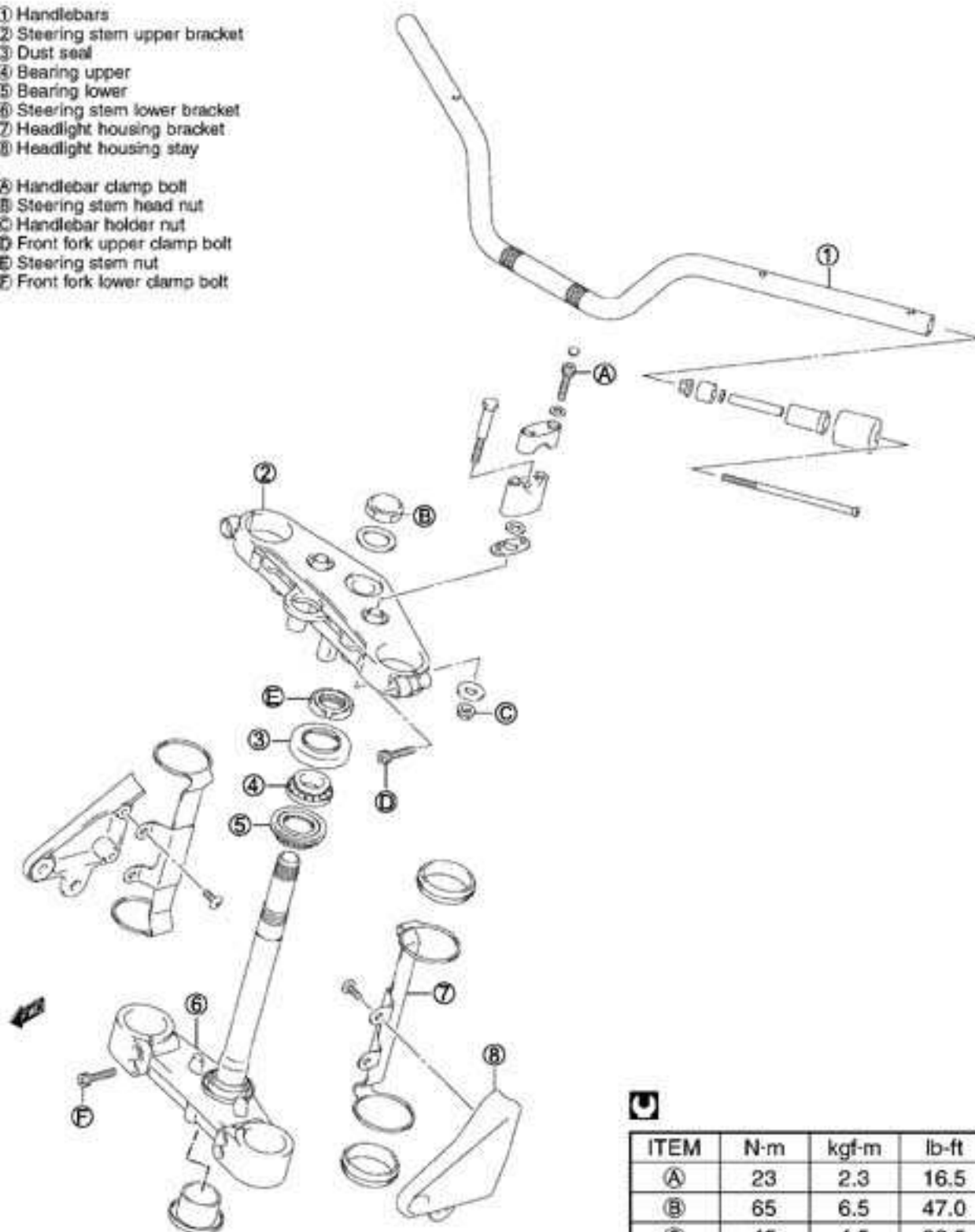

**G**

ITEM	N-m	kgf-m	lb-ft
Ⓐ	23	2.3	16.5
Ⓑ	65	6.5	47.0
Ⓒ	45	4.5	32.5
Ⓓ	23	2.3	16.5
Ⓔ	45	4.5	32.5
Ⓕ	23	2.3	16.5

**REMOVAL AND DISASSEMBLY**

- Remove the front wheel. (☞ 6-7)
  - Remove the front forks. (☞ 6-13)
  - Remove the headlight.
- 
- Disconnect all the lead wire couplers in the headlight housing.
  - Remove the headlight housing bolts.
- 
- Remove the brake hose joint mounting bolt.
  - Remove the headlight housing.
- 
- Remove the headlight housing brackets.
- 
- Remove the speedometer.



- Remove the rear view mirrors.



- Disconnect the front brake light switch lead wire coupler ①.
- Remove the front brake master cylinder along with brake hose and calipers.
- Remove the right handlebar switch box ② and throttle case ③.

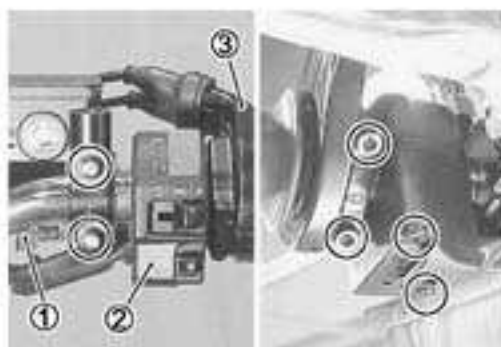

- Remove the handlebar balancers.

**NOTE:**

*The handlebar balancer mounting screws should be slightly loosened.*

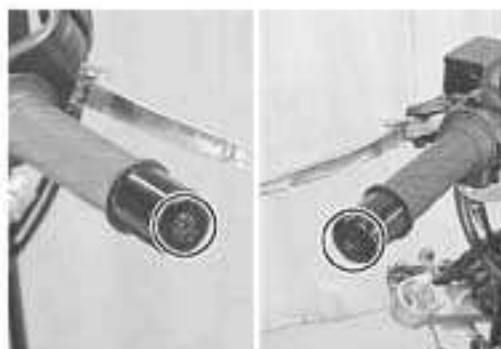

- Disconnect the clutch switch lead wires ④.



- Remove the left handlebar switch box ⑤.
- Remove the clutch master cylinder.

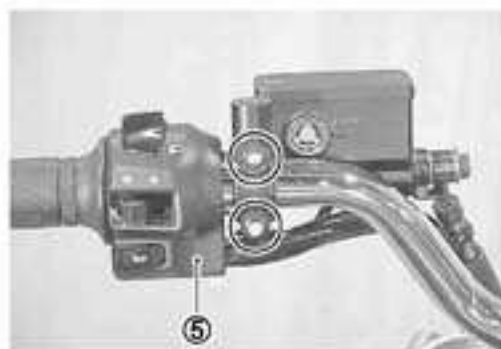



- Loosen the handlebar holder nuts.



- Remove the handlebar clamp bolt caps.
- Remove the handlebar by removing the handlebar clamp bolts.



- Remove the steering stem upper bracket by removing the steering stem head nut.



- Remove the steering stem nut with the steering stem nut wrench.

 09940-14911: Steering stem nut wrench

**NOTE:**

*Hold the steering stem lower bracket to prevent it from falling.*



- Remove the dust seal ①, the steering stem upper bearing ②.
- Remove the steering stem lower bracket.



- Remove the ignition switch. (7-29)

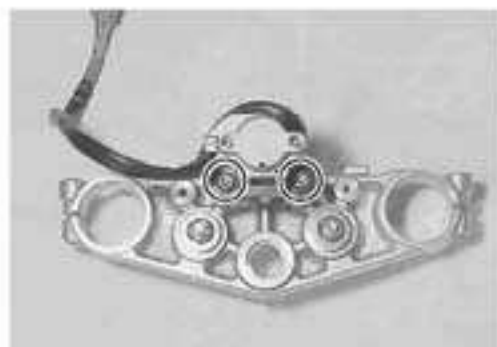

- Remove the handlebar holder.

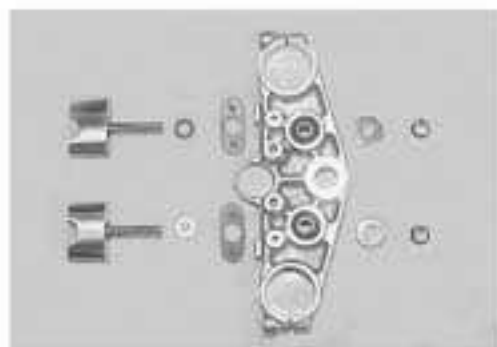

## INSPECTION AND DISASSEMBLY

Inspect the removed parts for the following abnormalities.

- Handlebars distortion
- Race wear and brinelling
- Bearing wear or damage
- Abnormal bearing noise
- Distortion of the steering stem

If any abnormal points are found, replace defective parts with the new ones.



- Remove the steering stem lower bearing inner race using a chisel.

### CAUTION

The removed bearing inner race and dust seal should be replaced with the new ones.

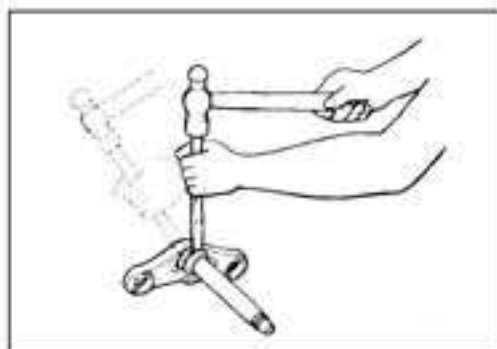

- Drive out the steering stem upper and lower bearing races using the special tools.

 09941-54911: Bearing outer race remover  
09941-74911: Steering bearing installer

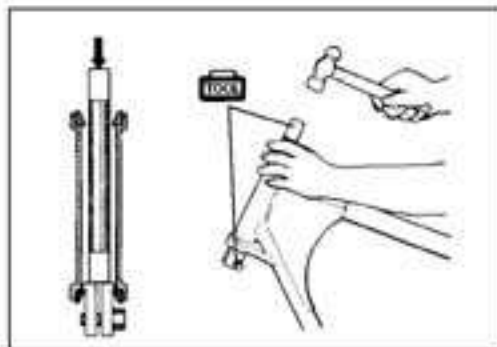

## REASSEMBLY AND REMOUNTING

Reassemble and remount the steering stem in the reverse order of removal and disassembly. Pay attention to the following points:

### OUTER RACES

- Press in the upper and lower outer races using the special tool.

 09941-34513: Steering outer race installer

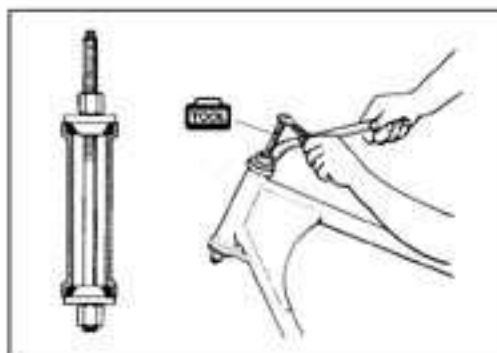

### BEARINGS

- Press in the lower bearing using the special tool.

 09941-74911: Steering bearing installer

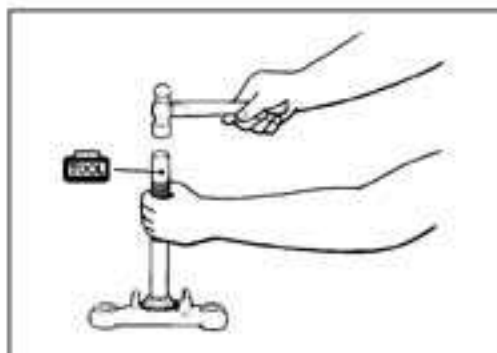

- Apply grease to the bearings and bearing races.
- Install the lower bearing to the steering stem lower bracket.
- Install the upper bearing, bearing inner race and dust seal.

 99000-25010: SUZUKI SUPER GREASE "A"

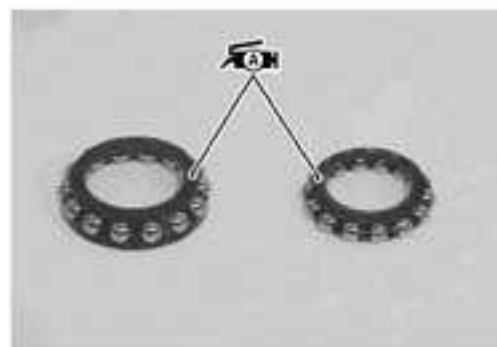

### STEERING STEM

- Tighten the steering stem nut to the specified torque with the steering stem nut wrench.

 09940-14911: Steering stem nut wrench

 Steering stem nut: 45 N·m (4.5 kgf·m, 32.5 lb-ft)



- Turn the steering stem about five or six times to the left and right so that the angular ball bearing will be seated properly.
- Loosen the steering stem nut by  $\frac{1}{4}$  –  $\frac{1}{2}$  turn.

#### NOTE:

*This adjustment will vary from motorcycle to motorcycle.*

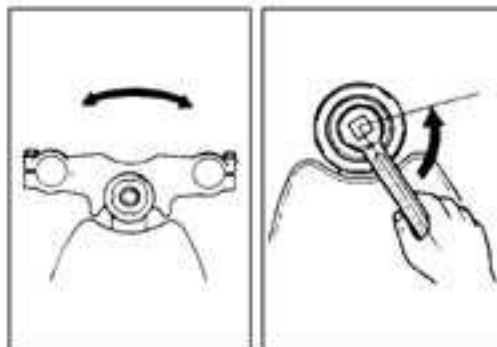

- Install the ignition switch. (☞7-29)
- Install the handlebar holders to the steering stem upper bracket.

**NOTE:**

Tighten the handlebar holder nuts ① lightly.

After installing handlebars, it should be tightened to the specified torque.

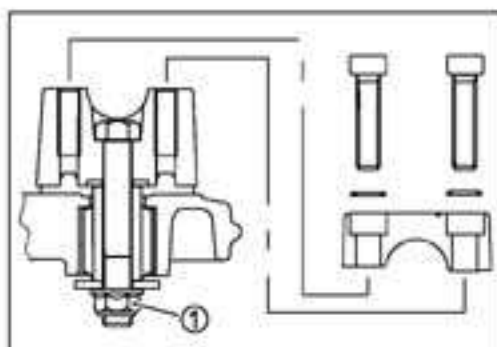

- Install the steering stem upper bracket and tighten the steering stem nut lightly.
- Install the front fork to the steering stem and tighten the lower clamp bolts temporarily.



- Tighten the steering stem head nut to the specified torque.

 **Steering stem head nut: 65 N·m (6.5 kgf·m, 47.0 lb-ft)**

**FRONT FORK**

- Remount the front forks. (☞6-17)

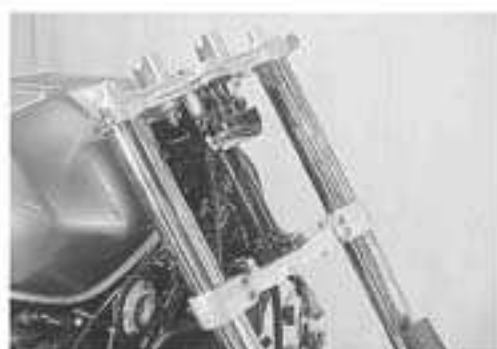
**HANDLEBARS**

- Set the punched mark to the mating surface of the handlebar holder.



- Set the punched mark on the handlebar clamp forward.
- Tighten the handlebar clamp bolts.

 **Handlebar clamp bolt: 23 N·m (2.3 kgf·m, 16.5 lb-ft)**

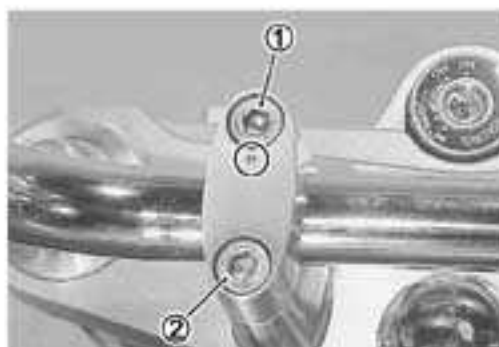





- Tighten the handlebar holder nuts to the specified torque.

 **Handlebar holder nut: 45 N·m (4.5 kgf·m, 32.5 lb-ft)**



#### HANDLEBAR SWITCH BOX

- Install the right handlebar switch box to the handlebars by engaging the stopper  with the handlebar hole .
- Install the front brake master cylinder. ( 6-62)
- (Brake hose routing:  8-22)



- Install the throttle cable case. (Throttle cable routing:  8-20)
- Apply the grease to the throttle cables and their holes.

 **99000-25010: SUZUKI SUPER GREASE "A"**





- Squeeze the brake lever fully and check or adjust the clearance (between the brake lever and throttle cable case) to provide more than 2 mm (0.08 in).
- Adjust the throttle cable play. ( 2-15)



- Install the left handlebar switch box to the handlebars by engaging the stopper ① with the handlebars hole ②.
- Install the clutch master cylinder with the proper clutch hose routing. (Clutch hose routing:  8-19)



- Install the handlebar barancers and the rear view mirrors.
- Install the speedometer, the headlight housing and the headlight.
- Install the front wheel. ( 6-9)
- Adjust the headlight beam. ( 7-28)

## STEERING TENSION ADJUSTMENT

Check the steering movement in the following procedure.

- By supporting the motorcycle with a jack, lift the front wheel until it is off the floor by 20 – 30 mm (0.8 – 1.2 in).
- Check to make sure that the cables and wire harnesses are properly routed.
- With the front wheel in the straight ahead state, hitch the spring scale (special tool) on one handlebar grip end as shown in the figure and read the graduation when the handlebar starts moving. Do the same on the other grip end.

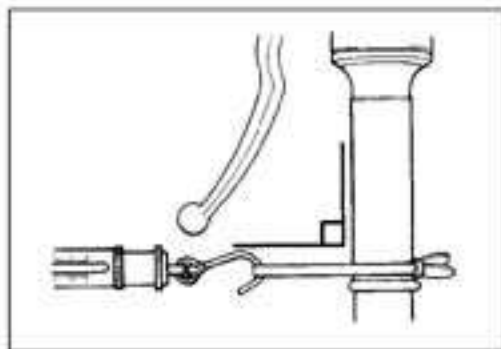

**DATA** Initial force: 200 – 500 grams

**BOX** 09940-92720: Spring scale

- If the initial force read on the scale when the handlebar starts turning is either too heavy or too light, adjust it till it satisfies the specification.
- 1) First, loosen the front fork upper and lower clamp bolts, steering stem head nut and steering stem lock nut, and then adjust the steering stem nut by loosening or tightening it.
  - 2) Tighten the steering stem lock nut, stem head nut and front fork upper and lower clamp bolts to the specified torque and re-check the initial force with the spring scale according to the previously described procedure.
  - 3) If the initial force is found within the specified range, adjustment has been completed.

### NOTE:

Hold the front fork legs, move them back and forth and make sure that the steering is not loose.





## REAR WHEEL CONSTRUCTION

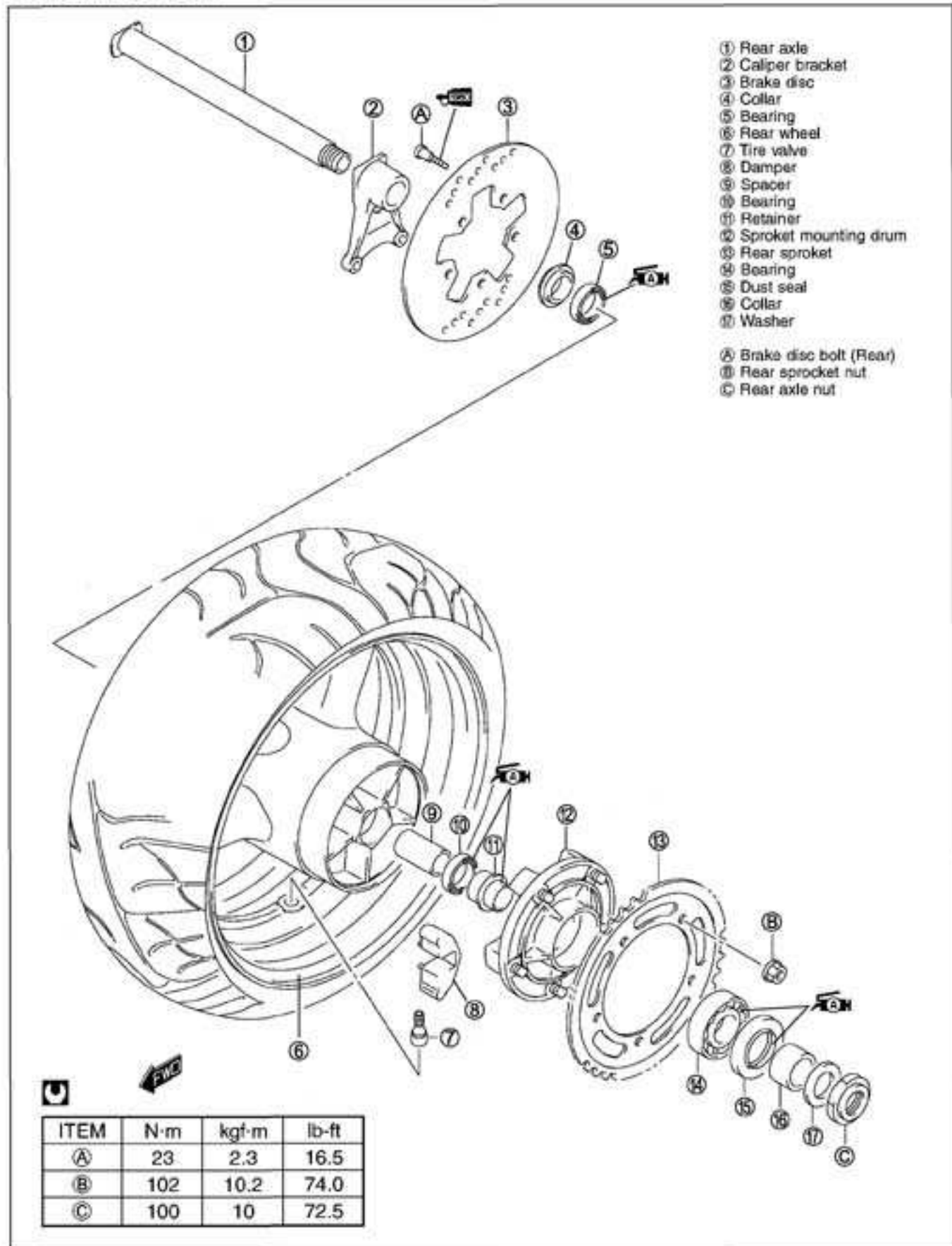

## REMOVAL

- Loosen the rear axle nut ①.
- Raise the rear wheel off the ground and support the motorcycle with the center stand.
- Remove the axle nut and draw out the rear axle.

### CAUTION

**Do not operate the brake pedal while removing the rear wheel.**

- Remove the collar ②.
- Draw out the rear sprocket mounting drum ③ from the wheel hub.

### NOTE:

*Before removing the rear sprocket mounting drum, slightly loosen the rear sprocket nuts.*

- Remove the rear sprocket mounting drum retainer ④.
- Separate the rear sprocket from its mounting drum by removing nuts.

- Remove the dust seal by using special tool.

 09913-50121: Oil seal remover

### CAUTION

**Never reuse the removed dust seal.**

- Remove the brake disc.

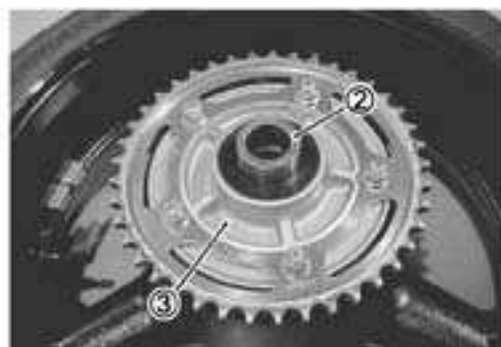

## INSPECTION AND DISASSEMBLY

**TIRE INSPECTION:** ☞ 6-70

**WHEEL INSPECTION:** ☞ 6-7 and 6-70

### REAR AXLE

Using a dial gauge, check the rear axle for runout.  
If the runout exceeds the limit, replace the rear axle.

**DATA** Axle shaft runout: Service Limit: 0.25 mm (0.010 in)

**TOOL** 09900-20607: Dial gauge (1/100 mm)

09900-20701: Magnetic stand

09900-21304: V-block set (100 mm)

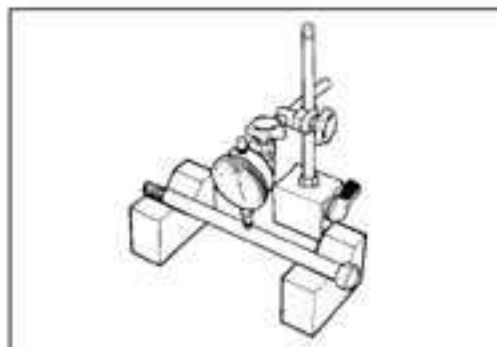

### WHEEL DAMPER

Inspect the dampers for wear and damage.  
Replace the damper if there is anything unusual.

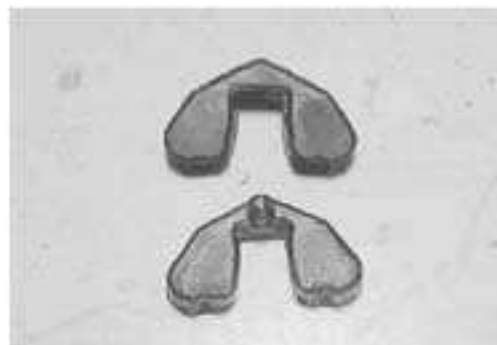

### SPROCKET

Inspect the rear sprocket teeth for wear. If they are worn as shown, replace the engine sprocket, rear sprocket and drive chain as a set.

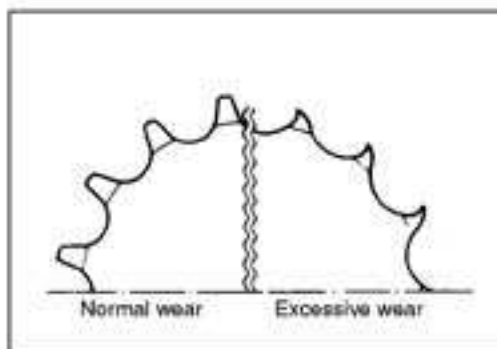

### BEARING

Inspect the play of the wheel and sprocket mounting drum bearings by hand while they are in the wheel and drum. Rotate the inner race by hand to inspect for abnormal noise and smooth rotation. Replace the bearing if there is anything unusual.

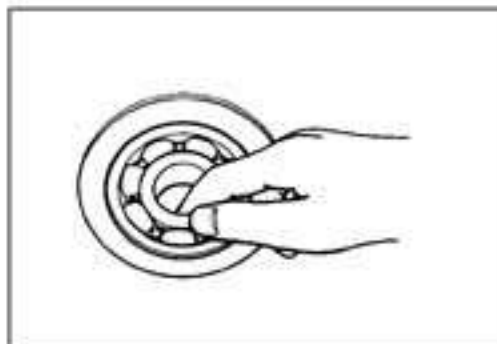

- Remove the sprocket mounting drum bearing and wheel bearings by using the special tool.

 09921-20240: Bearing remover set

**CAUTION**

The removed bearings must be replaced with the new ones.



**REASSEMBLY AND REMOUNTING**

Reassemble and remount the rear wheel in the reverse order of removal and disassembly. Pay attention to the following points:

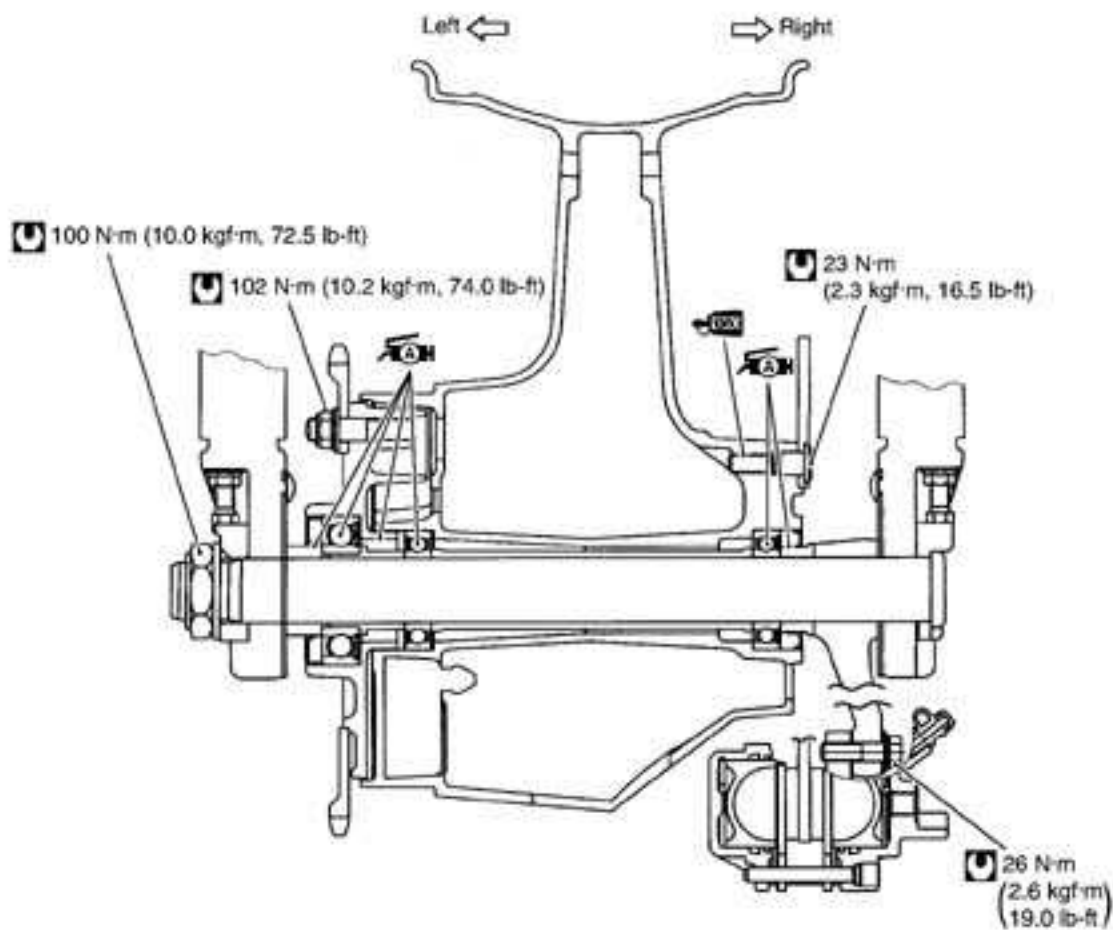

**BEARING**

- Apply grease to the bearings before installing.

 99000-25010: SUZUKI SUPER GREASE "A"



- Install the new bearing to the sprocket mounting drum using the special tool.

 09924-84510: Bearing installer set



- First install the right wheel bearing, then install the left wheel bearing and spacer using the special tool.

 09941-34513: Bearing/Steering race installer set

**CAUTION**

The sealed cover of the bearing must face outside.

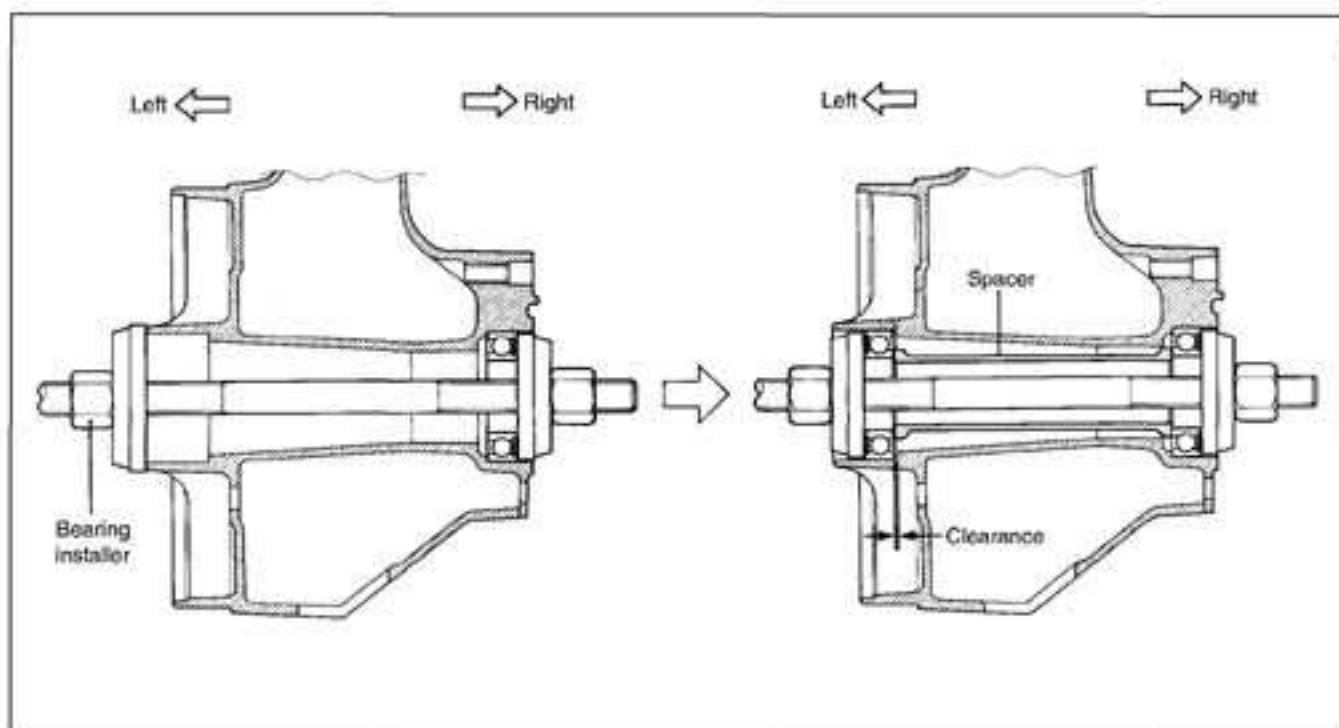



**DUST SEAL**

- Install the new dust seal using proper drift.
- Apply grease to the dust seal lip before assembling rear wheel.

 99000-25010: SUZUKI SUPER GREASE "A"

**BRAKE DISC**

- Apply THREAD LOCK SUPER "1360" to the disc bolts and tighten them to the specified torque.

**NOTE:**

*Make sure that the brake disc is clean and free of any greasy matter.*

 99000-32130: THREAD LOCK SUPER "1360"

 Brake disc bolt: 23 N·m (2.3 kgf·m, 16.5 lb-ft)

**REAR SPROCKET**

- Tighten the sprocket mounting nuts to the specified torque.

 Rear sprocket nut: 102 N·m (10.2 kgf·m, 74.0 lb-ft)

**NOTE:**

*Stamped mark on the sprocket should face outside.*



- Apply grease to the rear sprocket mounting retainer.
- Install the rear sprocket mounting drum retainer.
- Apply grease to the contacting surface between the rear wheel and the sprocket drum.

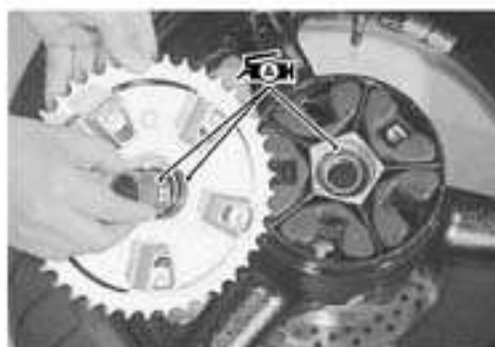

- Install the rear sprocket mounting drum.
- Install the collar.



**REAR AXLE**

- Remount the rear wheel and rear axle, install the washer and rear axle nut.
- Tighten the rear axle nut ① to the specified torque.
- Adjust the chain slack after rear wheel installation. (☞ 2-17)

**🔩 Rear axle nut: 100 N·m (10.0 kgf·m, 72.5 lb-ft)**



## REAR SHOCK ABSORBER CONSTRUCTION

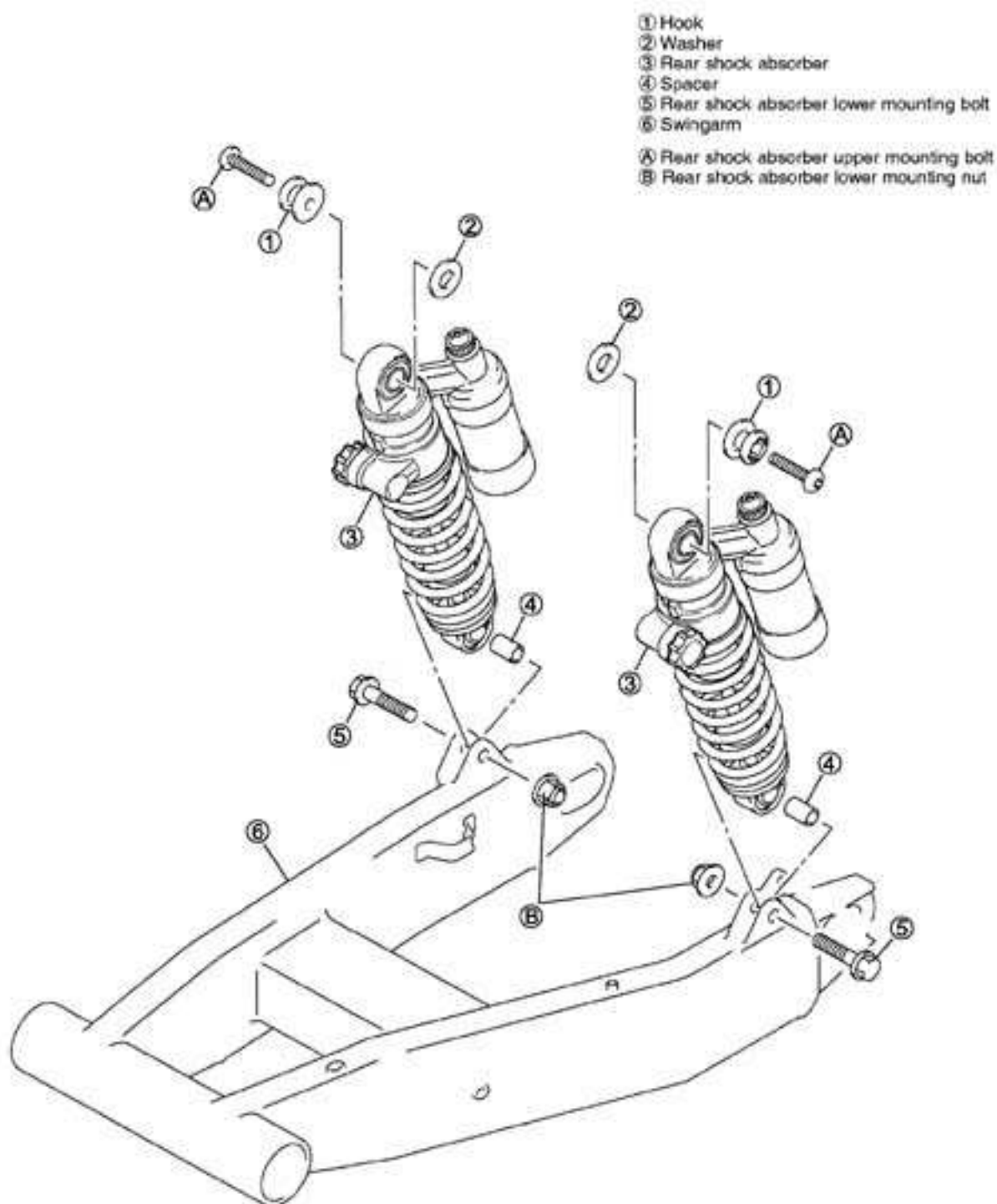

ITEM	N-m	kgf-m	lb-ft
A	23	2.3	16.5
B	34	3.4	24.5

## REMOVAL

- Raise the rear wheel off the ground and support the motorcycle with the center stand.
- Remove the left muffler. (☐ 3-4)



- Remove the rear shock absorber upper mounting bolt.



- Loosen the rear shock absorber lower mounting bolt.



- Dismount the rear shock absorber's upper side from the frame.



- Remove the rear shock absorbers by removing the lower bolts.



## INSPECTION

Inspect the shock absorber body and bushing for damage and oil leakage.

If any defects are found, replace the shock absorber with a new one.

### CAUTION

Do not attempt to disassemble the rear shock absorber unit. It is unserviceable.

## REAR SHOCK ABSORBER SCRAPPING PROCEDURE

### ⚠ WARNING

- Handle the rear shock absorber with caution since a high pressure nitrogen gas is contained.
- Avoid incineration, exposure to high pressure or overhauling.
- In the case of scrapping the rear shock absorber, evacuate gas in the following procedures. In the case of scrapping the rear shock absorber, evacuate gas in the following procedures.

### REAR SHOCK ABSORBER GAS EVACUATION

- Remove the valve cover ①.
- Remove the valve cap ②, evacuate gas by depressing the valve.

### ⚠ WARNING

Keep your face away from the valve hole.

## REMountING

Remount the rear shock absorbers in the reverse order of removal. Pay attention to the following points:

- Install the rear shock absorber and tighten the rear shock absorber upper/lower mounting bolts and nuts.

**🔩** Rear shock absorber mounting lower bolt:  
34 N·m (3.4 kgf·m, 24.5 lb-ft)

**🔩** Rear shock absorber mounting upper bolt:  
23 N·m (2.3 kgf·m, 16.5 lb-ft)

- Install the left muffler. (🔧3-10)

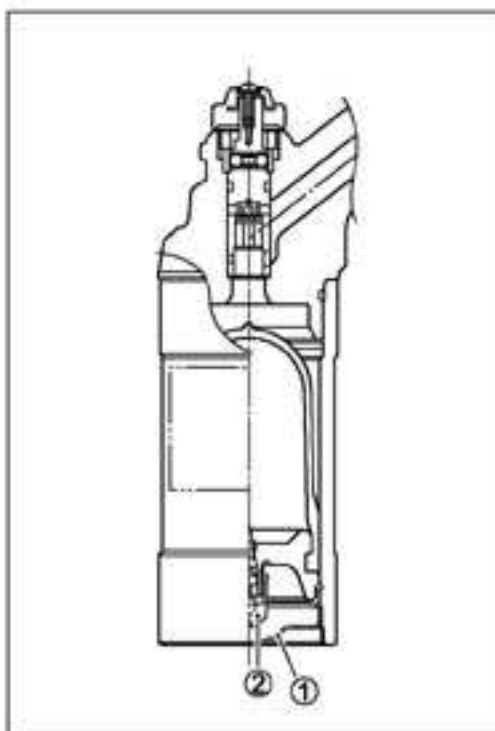

## SUSPENSION SETTING

After installing the rear suspension, adjust the spring pre-load and damping force as follows.

### SPRING PRE-LOAD ADJUSTMENT

Position "1" provides the softest spring pre-load.

Position "5" provides the stiffest spring pre-load.

**STD position: "1.5"**

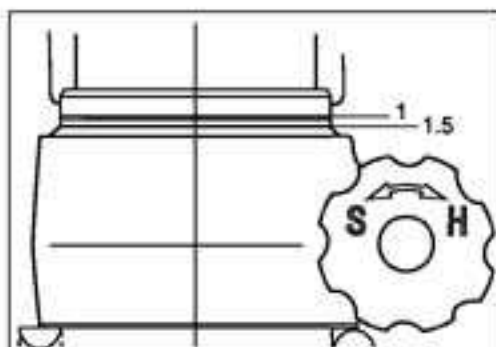

STD position

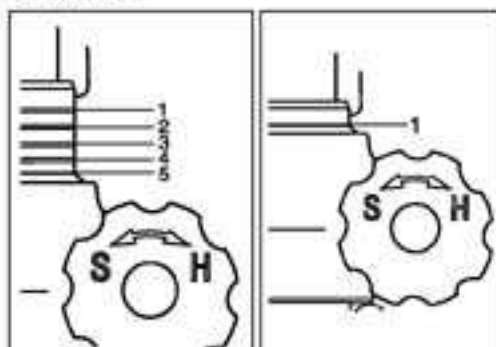

Stiffest position

Softest position

### DAMPING FORCE ADJUSTMENT

The rebound and compression damping force can be individually adjusted by turning the respective adjusters.

#### Compression side

Position "1" provides the softest rebound damping force.

Position "4" provides the stiffest rebound damping force.

**STD position: Position "2"**



Compression side

#### Rebound side

Position "I" provides the softest rebound damping force.

Position "IIII" provides the stiffest rebound damping force.

**STD position: "II"**

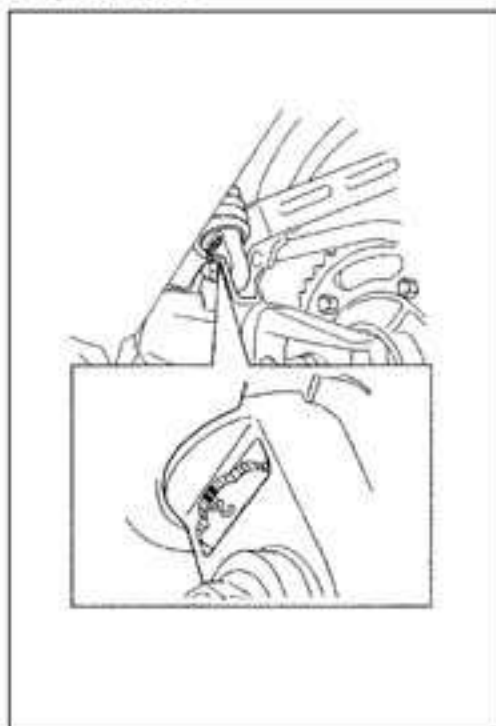

Rebound side

### CAUTION

Be sure that the damping adjusters are firmly located in a detent, and not between positions.

### WARNING

Be sure to adjust the spring pre-load and damping force on the both suspensions equally.

## REAR SWINGARM CONSTRUCTION

- ① Swingarm
- ② Bearing
- ③ Spacer
- ④ Chain buffer
- ⑤ Dust seal
- ⑥ Washer
- ⑦ Bearing spacer
- ⑧ Pivot shaft
- Ⓐ Swingarm pivot nut

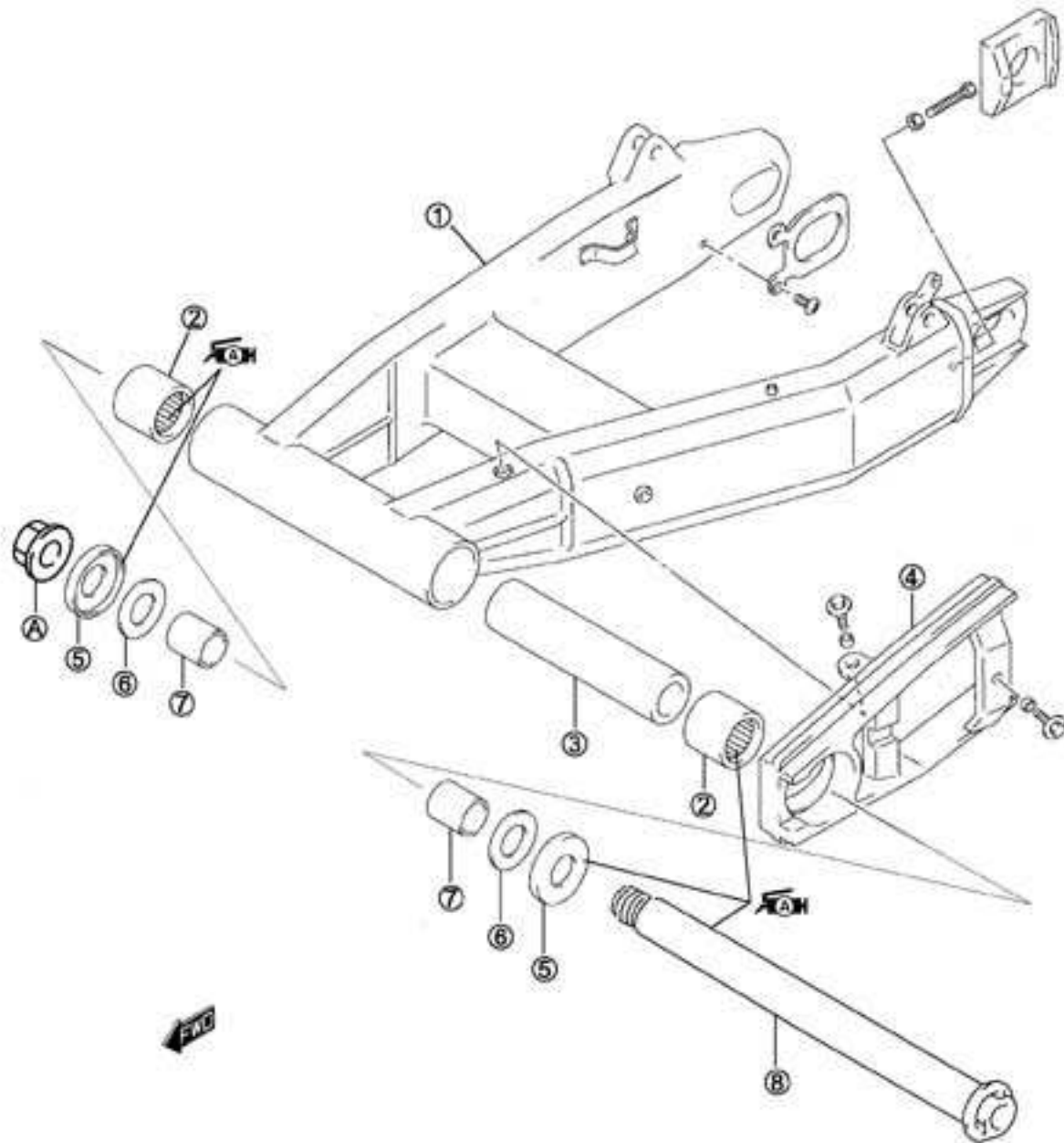

ITEM	N-m	kgf-m	lb-ft
Ⓐ	120	12.0	87.0



## REMOVAL

- Raise the rear wheel off the ground and support the motorcycle with the center stand.
- Remove the rear wheel. (☞ 6-33)
- Remove the rear shock absorbers. (☞ 6-41)
- Remove the rear brake hose guide ①.



- Remove the touque link.
- Remove the rear brake hose union bolt at the rear brake caliper.

### CAUTION

Completely wipe off any brake fluid adhering to any part of motorcycle. The fluid reacts chemically with paint, plastics, rubber materials and so on.



- Remove the pivot shaft cap.
- Remove the swingarm by removing the pivot shaft.



- Remove the chain case.

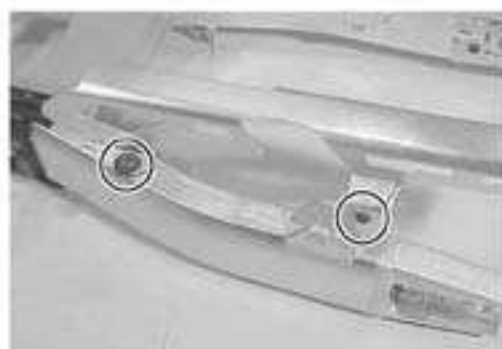

## INSPECTION AND DISASSEMBLY

### DUST SEAL AND SPACER

- Remove the dust seals ①, washers ② and spacers ③ from swingarm.
- Inspect the spacers for any flaws or other damage. If any defects are found, replace the spacers with the new ones.

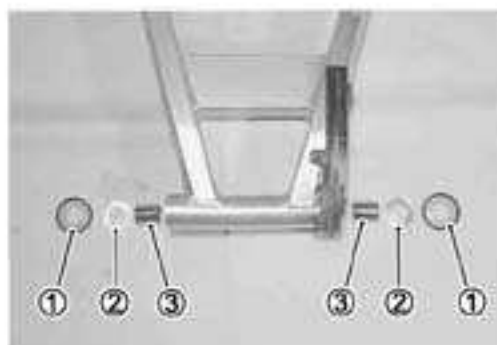

### CHAIN BUFFER

- Remove the chain buffer.
- Inspect the chain buffer for wear and damage. If any defects are found, replace the chain buffer with a new one.



### SWINGARM BEARING

Insert the spacer into bearing and check the play when moving the spacer up and down.

If excessive play is noted, replace the bearing with a new one.



- Remove the swingarm bearing and spacer with the special tools.

**TOOL** 09941-64511: Bearing remover  
09930-30102: Sliding shaft

### CAUTION

Never reuse the removed bearings.

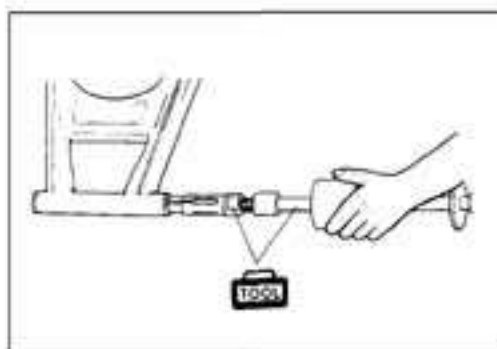

### SWINGARM PIVOT SHAFT

Using a dial gauge, check the pivot shaft runout and replace it if the runout exceeds the limit.

**TOOL** 09900-20607: Dial gauge (1/100 mm, 10 mm)  
09900-20701: Magnetic stand  
09900-21304: V-block (100 mm)

**DATA** Swingarm pivot shaft runout:  
Service limit: 0.3 mm (0.01 in)

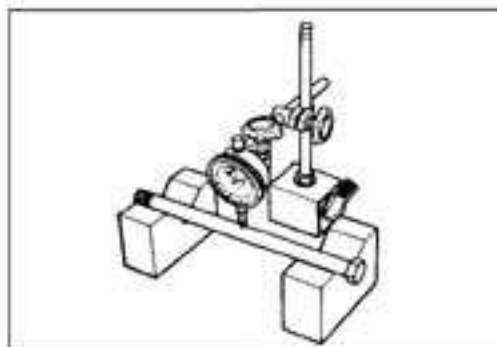

## REASSEMBLY

Reassemble the swingarm in the reverse order of disassembly and removal.

Pay attention to the following points:

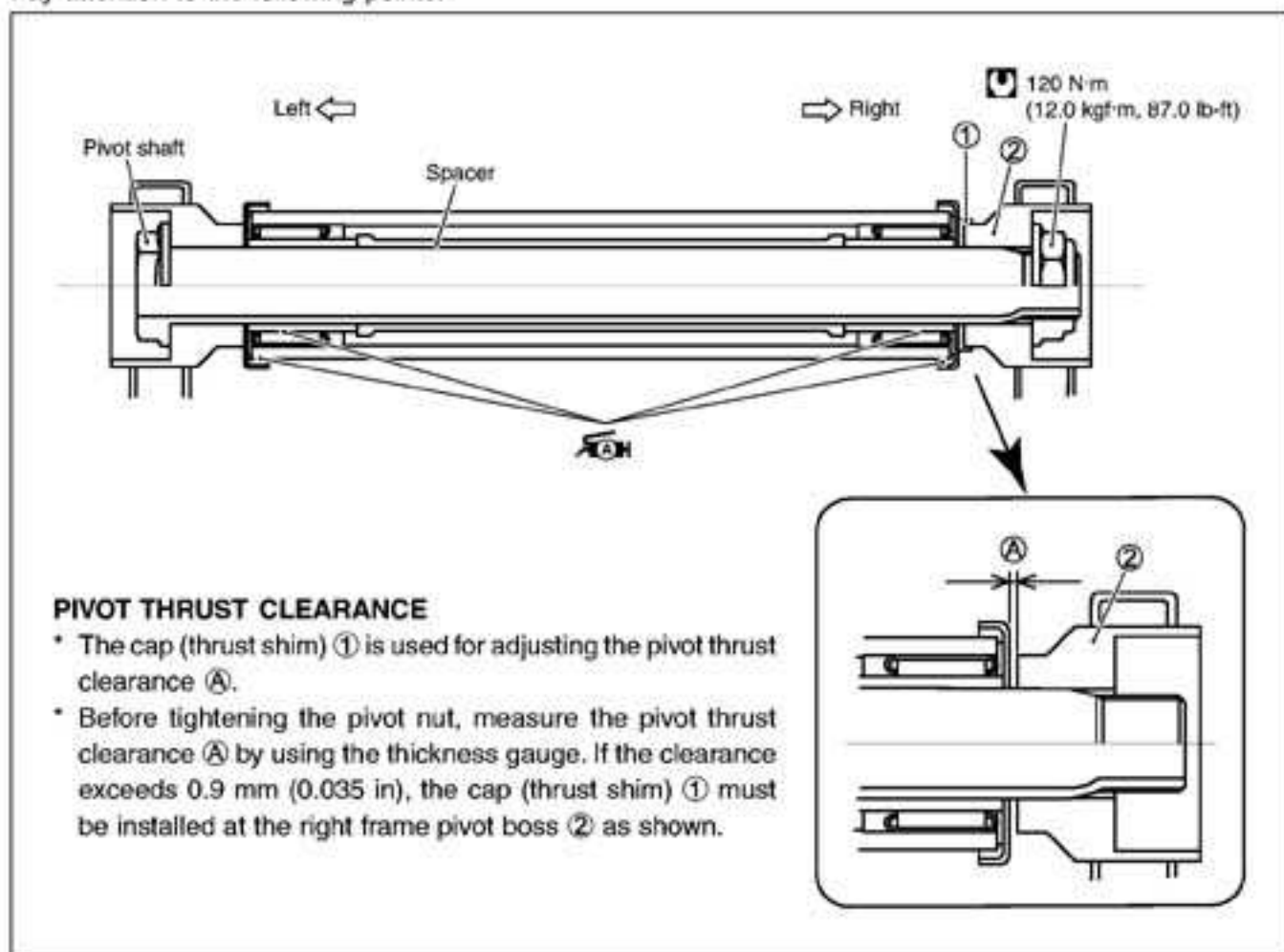

## SWINGARM BEARING

- Install the bearings and spacer into the swingarm pivot by using the special tool.

 09941-34513: Steering race installer



- Apply grease to the bearings and spacers and dust seals.
- Install the bearings, spacers, washers and dust seals.

 99000-25010: SUZUKI SUPER GREASE "A"

- Install the chain buffer to the swingarm.
- Install the chain case to the swingarm.



## REMountING

Remount the swingarm in the reverse order of disassembly and removal, and pay attention to the following points:

### SWINGARM



- Insert the swingarm pivot shaft and tighten it to the specified torque.

 **Swingarm pivot nut: 120 N·m (12.0 kgf·m, 87.0 lb-ft)**

- Install the pivot shaft caps.

- Install the touque link.

 **Touque link bolt/nut: 28 N·m (2.8 kgf·m, 20.5 lb-ft)**

- Install the rear shock absorbers. ( 6-42)
- Install the rear brake hose guide. ( 6-36)
- Install the rear wheel. ( 6-36)

- Install the rear brake hose with the proper brake hose routing. (Rear brake hose routing:  8-23)

 **Brake hose union bolt: 23 N·m (2.3 kgf·m, 16.5 lb-ft)**



### CAUTION

Bleed air from the brake system. ( 2-22)



## FINAL INSPECTION AND ADJUSTMENT

After installing the rear suspension and wheel, the following adjustments are required before driving.

- Drive chain:  2-17
- Tire pressure:  6-72
- Chassis bolts and nuts:  2-25

## FRONT BRAKE CONSTRUCTION

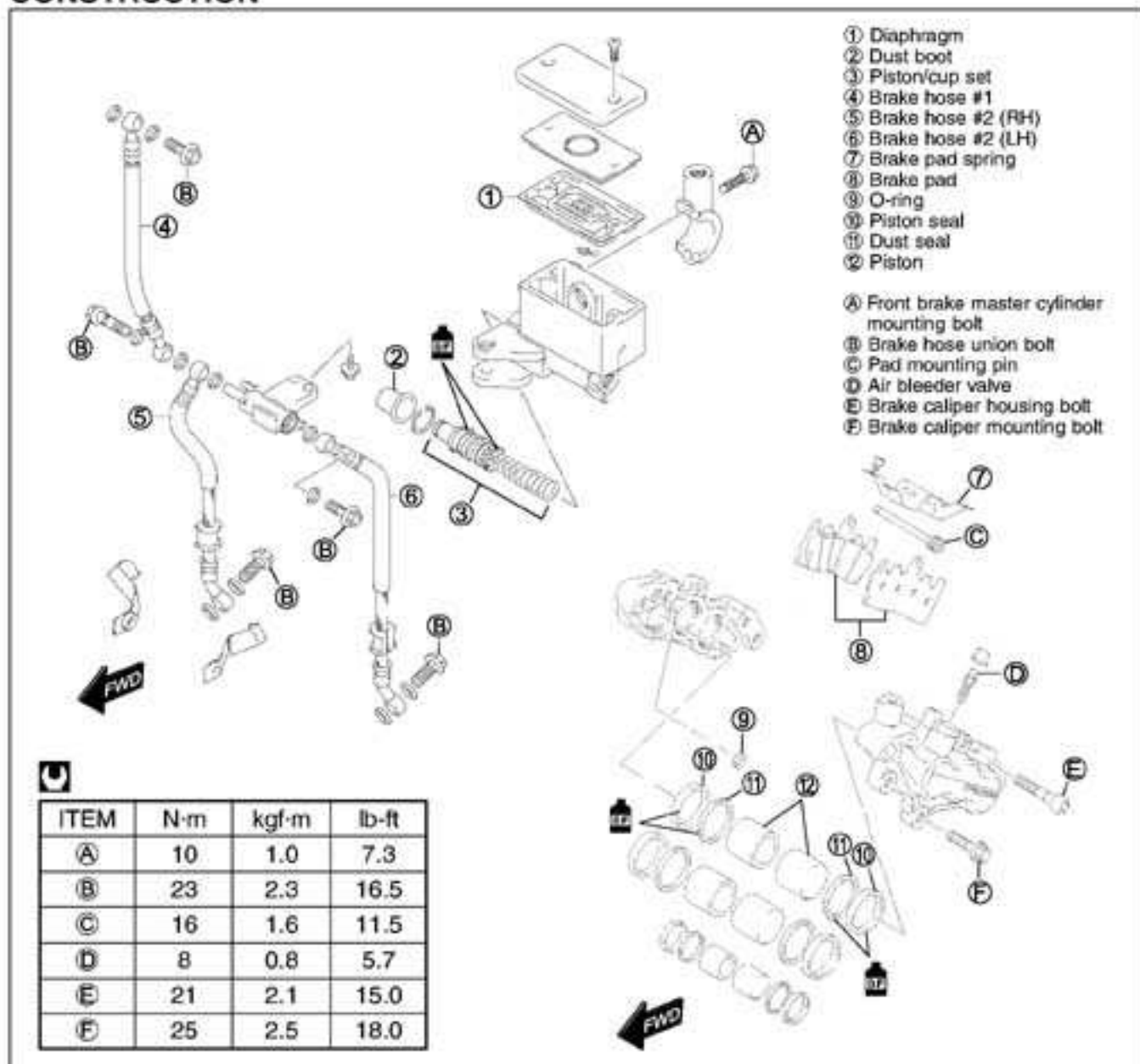

### ▲ WARNING

- This brake system is filled with an ethylene glycol-based DOT 4 brake fluid. Do not use mix different types of fluid such as silicone-based or petroleum-based.
- Do not use any brake fluid taken from old, used or unsealed containers. Never reuse brake fluid left over from the last servicing or stored for long periods.
- When storing the brake fluid, seal the container completely and keep away from children.
- When replenishing brake fluid, take care not to get dust into fluid.
- When washing brake components, use fresh brake fluid. Never use cleaning solvent.
- A contaminated brake disc or brake pad reduces braking performance. Discard contaminated pads and clean the disc with high quality brake cleaner or neutral detergent.

### CAUTION

Handle brake fluid with care: the fluid reacts chemically with paint, plastics, rubber materials etc. and will damage them severely.

## BRAKE PAD REPLACEMENT

- Remove the pad spring ①.
- Remove the brake pads by removing the pad mounting pin ②.

### CAUTION

- Do not operate the brake lever while dismantling the pads.
- Replace the brake pads as a set, otherwise braking performance will be adversely affected.

- Clean up the caliper especially around the caliper pistons.
- Install the new brake pads so the brake disc is positioned between the pads.

 Pad mounting pin: 16 N·m (1.6 kgf·m, 11.5 lb-ft)

### NOTE:

After replacing the brake pads, pump the brake lever few times to check for proper brake operation and then check the brake fluid level.

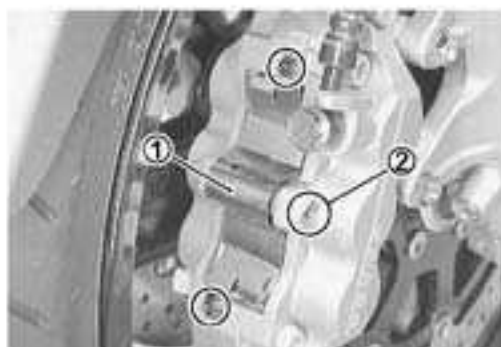

## BRAKE FLUID REPLACEMENT

- Place the motorcycle on a level surface and keep the handlebars straight.
- Remove the brake fluid reservoir cap and diaphragm.
- Suck up the old brake fluid as much as possible.
- Fill the reservoir with the new brake fluid.



- Connect a clear hose to the caliper air bleeder valve and insert the other end of hose into a receptacle.
- Loosen the air bleeder valve and pump the brake lever until old brake fluid flows out of the bleeder system.
- Close the caliper air bleeder valve and disconnect a clear hose. Fill the reservoir with the new fluid to the upper mark of the reservoir.



 Specification and Classification: DOT 4

### CAUTION

Bleed air from the brake system. (2-21)





## CALIPER REMOVAL AND DISASSEMBLY

- Drain the brake fluid. (☞ 6-50)
- Remove the brake pads. (☞ 6-50)
- Disconnect the brake hoses by removing the brake hose union bolts.

### NOTE:

Place a rag underneath the union bolt on the brake caliper to catch any spilt brake fluid.

- Remove the brake calipers by removing the caliper mounting bolts.

### NOTE:

Slightly loosen the caliper housing bolts before removing the caliper mounting bolts to facilitate later disassembly.

### CAUTION

Never reuse the brake fluid left over from previous servicing and stored for long periods of time.

### ▲ WARNING

Brake fluid, if it leaks, will interfere with safe running and discolor painted surfaces. Check the brake hose and hose joints for cracks and fluid leakage.

- Separate the caliper halves to remove the caliper housing bolts.

- Remove the O-ring.

### CAUTION

Replace the O-ring with a new one.

- Place a rag over the pistons to prevent them from popping out and then force out the pistons using compressed air.

### CAUTION

Do not use high pressure air to prevent piston damage.





- Remove the dust seals and piston seals.

**CAUTION**

Never reuse the removed dust seals and piston seals to prevent fluid leakage.

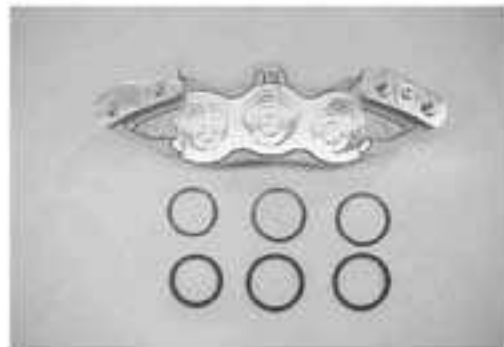
**CALIPER INSPECTION****BRAKE CALIPER**

Inspect the brake caliper cylinder wall for nicks, scratches or other damage.

**BRAKE CALIPER PISTON**

Inspect the brake caliper piston surface for any scratches or other damage.

**CALIPER REASSEMBLY AND REMOUNTING**

Reassemble the caliper in the reverse order of removal and disassembly. Pay attention to the following points:

- Wash the caliper bores and pistons with specified brake fluid. Particularly wash the dust seal grooves and piston seal grooves.

 Specification and Classification: DOT 4

**CAUTION**

- Wash the caliper components with fresh brake fluid before reassembly. Never use cleaning solvent or gasoline to wash them.
- Do not wipe the brake fluid off after washing the components with a rag.
- When washing the components, use the specified brake fluid. Never use different types of fluid or cleaning solvent such as gasoline, kerosine or the others.
- Replace the piston seals and dust seals with the new ones when reassembly. Apply the brake fluid to both seals when installing them.

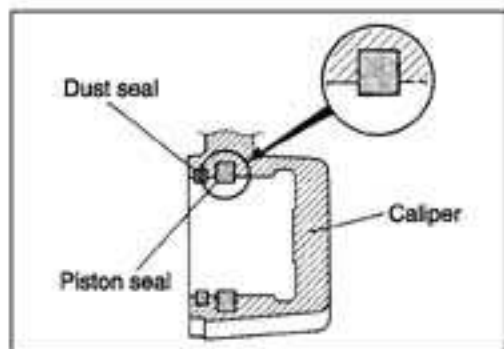
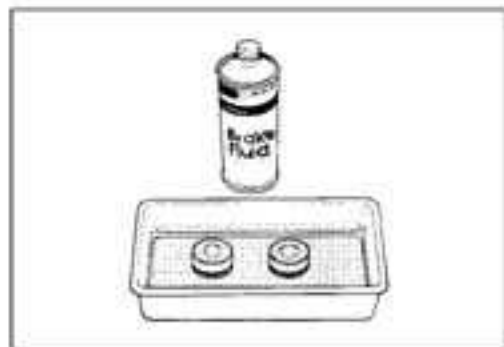
**PISTON SEAL**

- Install the piston seals as shown in the illustration.
- Install the pistons to the caliper halves.

**O-ring**

- Install the new O-ring and reassemble caliper halves.

**CAUTION**

Replace the O-ring with a new one.

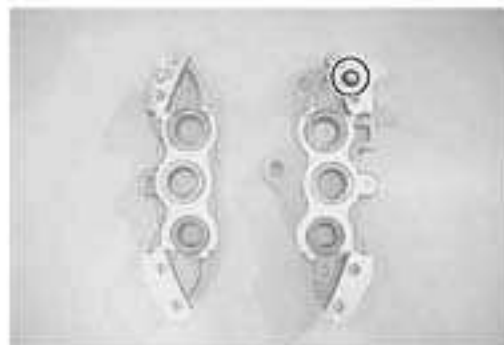

- Tighten each bolt to the specified torque.  
(Front brake hose routing:  8-22)

-  **Front brake caliper housing bolt ①:**  
21 N·m (2.1 kgf·m, 15.0 lb-ft)
- Front brake caliper mounting bolt ②:**  
25 N·m (2.5 kgf·m, 18.0 lb-ft)
- Front brake hose union bolt ③:**  
23 N·m (2.3 kgf·m, 16.5 lb-ft)

- Install the brake pads. ( 6-50)

**NOTE:**

Before remounting the caliper, push the piston all the way into the caliper.

**CAUTION**

- The seal washers should be replaced by the new ones to prevent fluid leakage.
- Bleed air from the system after reassembling the caliper. ( 2-21)

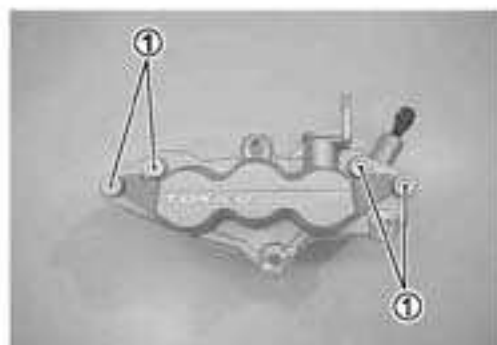

## BRAKE DISC INSPECTION

Visually check the brake disc for damage or cracks.  
Measure the thickness with a micrometer.

Replace the disc if the thickness is less than the service limit or if damage is found.

**DATA** Front disc thickness: Service Limit: 4.5 mm (0.18 in)

 09900-20205: Micrometer (0–25 mm)

- Remove the brake calipers. ( 6-51)

Measure the runout with a dial gauge.

Replace the disc if the runout exceeds the service limit.

**DATA** Front disc runout: Service Limit: 0.30 mm (0.012 in)

 09900-20607: Dial gauge (1/100 mm)  
09900-20701: Magnetic stand

- Brake disc removal ( 6-7)
- Brake disc installation ( 6-9)

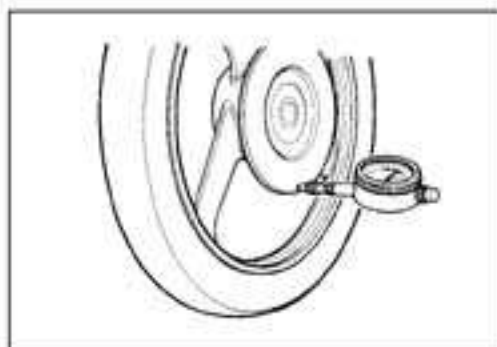
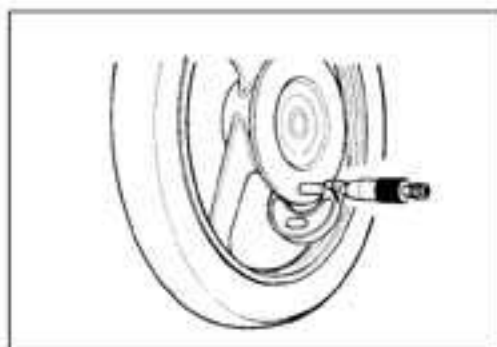

## MASTER CYLINDER REMOVAL AND DISASSEMBLY

- Drain the brake fluid. (6-50)
- Remove the rear view mirror.
- Disconnect the front brake light switch lead wire coupler ①.



- Place a rag underneath the union bolt on the master cylinder to catch any spilt brake fluid. Remove the brake hose union bolt and disconnect the brake hose.



### CAUTION

Immediately and completely wipe off any brake fluid contacting any part of the motorcycle. The fluid reacts chemically with paint, plastics and rubber materials, etc. and will damage them severely.

- Remove the master cylinder by removing the master cylinder mounting bolts.



- Remove the brake lever ② and brake switch ③.



- Pull out the dust boot ④ and remove the circlip ⑤.

 09900-06108: Snap ring pliers

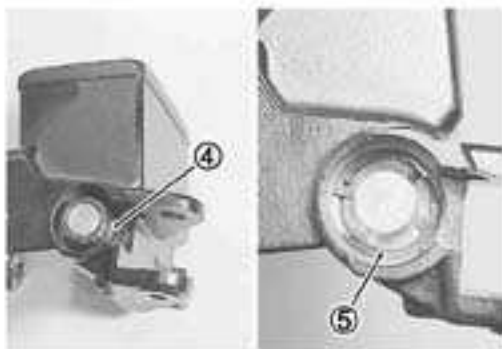

- Remove the piston/secondary cup, primary cup and return spring.
  - ① Piston
  - ② Secondary cup
  - ③ Primary cup
  - ④ Return spring

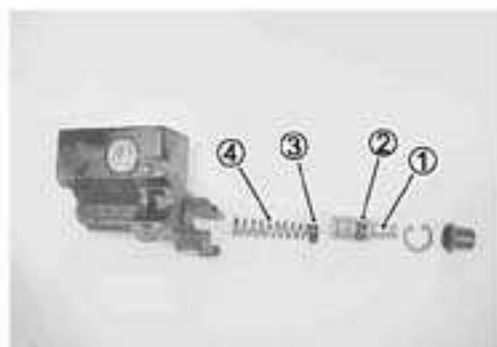

## MASTER CYLINDER INSPECTION

Inspect the master cylinder bore for any scratches or other damage.

Inspect the piston surface for any scratches or other damage.

Inspect the primary cup, secondary cup and dust seal for wear or damage.

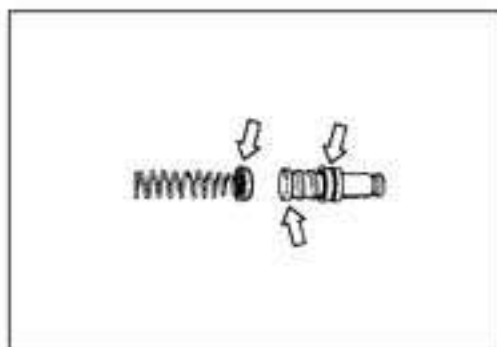

## MASTER CYLINDER REASSEMBLY AND REMOUNTING

Reassemble the master cylinder in the reverse order of removal and disassembly. Pay attention to the following points:

### CAUTION

- Wash the master cylinder components with fresh brake fluid before reassembly. Never use cleaning solvent or gasoline to wash them.
- Do not wipe the components with a rag.
- Apply brake fluid to the cylinder bore and all the component to be inserted into the bore.



 Specification and Classification: DOT 4

- Apply brake fluid to the piston and cups.
- Install the following parts to the master cylinder.
  - ① Dust boot
  - ② Circlip
  - ③ Secondary cup
  - ④ Piston
  - ⑤ Primary cup
  - ⑥ Return spring

 09900-06108: Snap ring pliers

- When remounting the brake master cylinder onto the handlebar, align the master cylinder holder's mating surface **A** with punched mark **B** on the handlebars and tighten the upper clamp bolt first as shown.

 Front brake master cylinder mounting bolt: 10 N·m  
(1.0 kgf·m, 7.3 lb-ft)

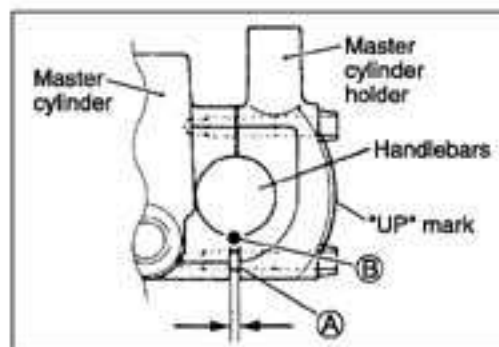
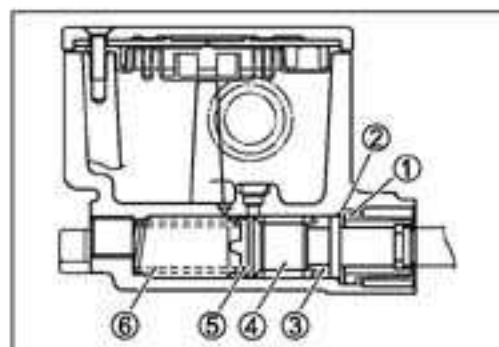

- Tighten the union bolt.  
(Brake hose routing:  8-22)

 Brake hose union bolt: 23 N·m (2.3 kgf·m, 16.5 lb-ft)

#### CAUTION

- The seal washers should be replaced by the new ones to prevent fluid leakage.
- Bleed air from the system after reassembling the master cylinder. ( 2-21)



#### INSPECTION AFTER REASSEMBLY

- Front brake:  2-19

## REAR BRAKE CONSTRUCTION

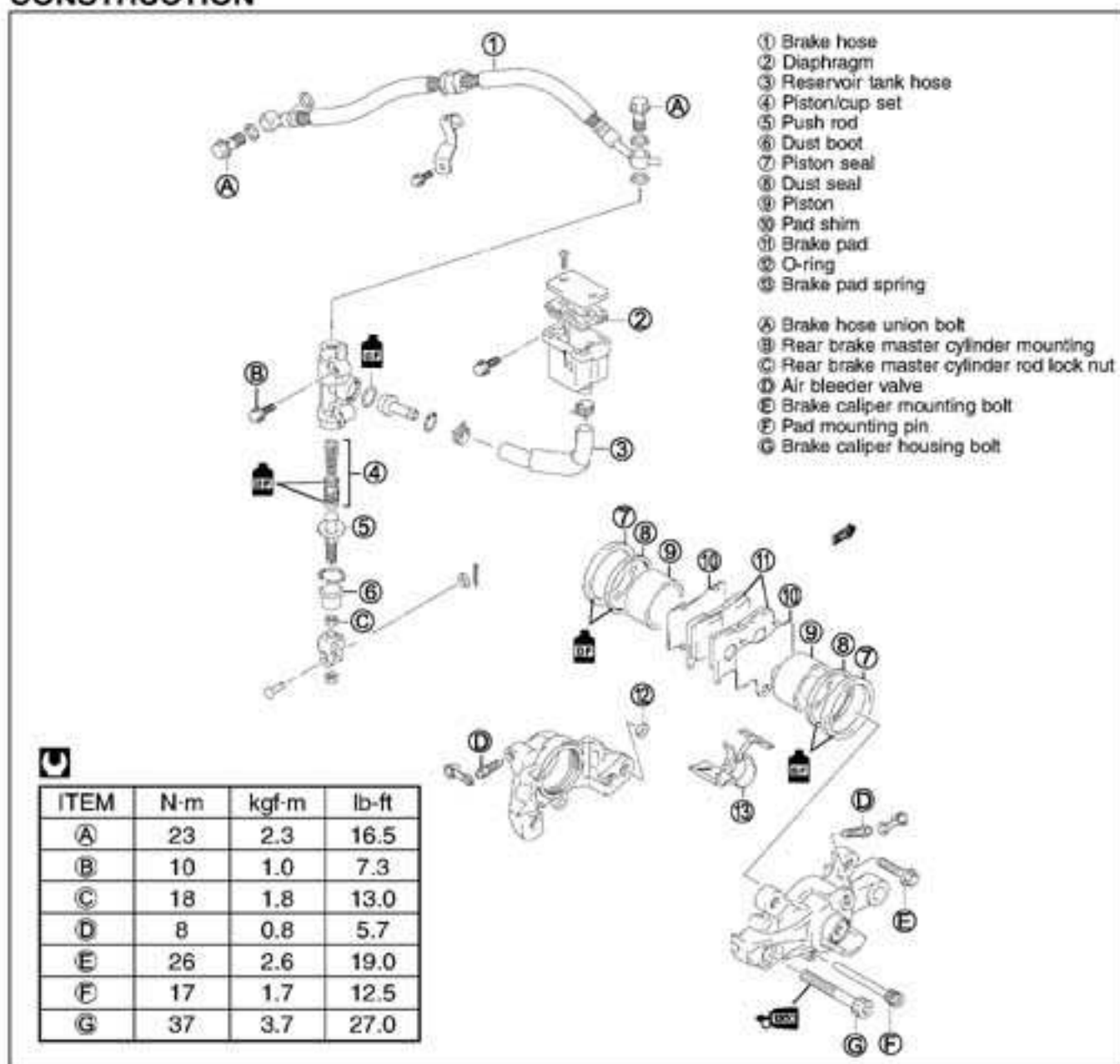

### ⚠ WARNING

- This brake system is filled with an ethylene glycol-based DOT 4 brake fluid. Do not use or mix different types of fluid such as silicone-based or petroleum-based.
- Do not use any brake fluid taken from old, used or unsealed containers. Never reuse brake fluid left over from the last servicing or stored for long periods.
- When storing the brake fluid, seal the container completely and keep away from children.
- When replenishing brake fluid, take care not to get dust into fluid.
- When washing brake components, use fresh brake fluid. Never use cleaning solvent.
- A contaminated brake disc or brake pad reduces braking performance. Discard contaminated pads and clean the disc with high quality brake cleaner or neutral detergent.

### ⚠ CAUTION

Handle brake fluid with care: the fluid reacts chemically with paint, plastics, rubber materials etc. and will damage them severely.

## BRAKE PAD REPLACEMENT

- Remove the pad mounting pin ①.
- Remove the brake pad spring ②.



- Remove the brake pads along with the pad shims.

### CAUTION

- Do not operate the brake pedal while dismantling the pads.
- Replace the brake pads as a set, otherwise braking performance will be adversely affected.



- Clean up the caliper especially around the caliper pistons.

- Install the new brake pads and shims ③ so the brake disc is positioned between the pads.

 Pad mounting pin: 17 N·m (1.7 kgf·m, 12.5 lb-ft)

### NOTE:

After replacing the brake pads, pump the brake pedal few times to operate the brake correctly and then check the brake fluid level.

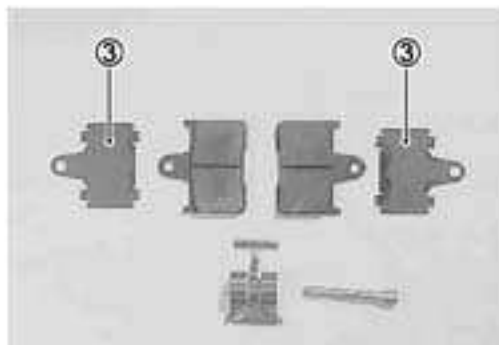

## BRAKE FLUID REPLACEMENT

- Remove the right frame cover. (☞6-3)
- Remove the brake fluid reservoir cap.
- Replace the brake fluid in the same manner as the front brake. (☞6-50)

 Specification and Classification: DOT 4

### CAUTION

Bleed air from the brake system. (☞2-22)





## CALIPER REMOVAL AND DISASSEMBLY

- Drain the brake fluid. (☞ 6-58)
- Remove the brake pads. (☞ 6-58)
- Disconnect the brake hose by removing the brake hose union bolt.

### CAUTION

Never reuse the brake fluid left over from previous servicing and stored for long periods.

### ▲ WARNING

Brake fluid, if it leaks, will interfere with safe running and discolor painted surfaces. Check the brake hose and hose joints for cracks and fluid leakage.

- Remove torque link bolt ① and the brake caliper mounting bolts ②.

### NOTE:

Slightly loosen the caliper housing bolts ③ to facilitate later disassembly before removing the caliper mounting bolts.

- Remove the caliper housing bolts ③.
- Separate the caliper halves.
- Remove the O-ring ④.

### CAUTION

Replace the O-ring with a new one.

- Place a rag over the piston to prevent it from popping out and then force out the pistons using compressed air.

### CAUTION

Do not use high pressure air to prevent piston damage.

- Remove the dust seals and piston seals.

### CAUTION

Do not reuse the dust seals and piston seals to prevent fluid leakage.

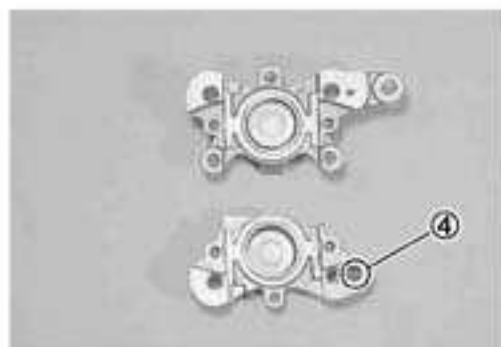
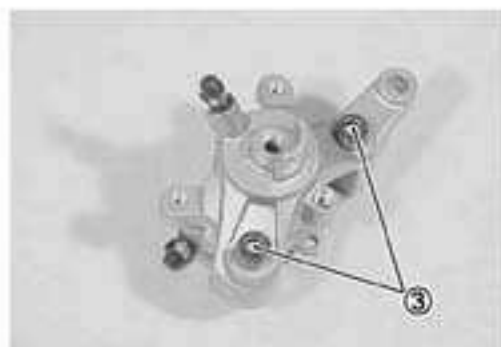

## CALIPER INSPECTION

CALIPER INSPECTION:  6-52

BRAKE DISC INSPECTION:  6-53

### DATA Service Limit

Rear disc thickness: 5.0 mm (0.20 in)

Rear disc runout: 0.30 mm (0.012 in)

## CALIPER REASSEMBLY AND REMOUNTING

Reassemble and remount the caliper in the reverse order of removal and disassembly. Pay attention to the following points:

### CAUTION

- Wash the caliper components with fresh brake fluid before reassembly. Never use cleaning solvent or gasoline to wash them.
- Apply brake fluid to the caliper bore and piston to be inserted into the bore.

 Specification and Classification: DOT 4

### PISTON SEAL

- Install the piston seals as shown in the right illustration.
- Install the pistons to the caliper halves.

### O-ring

- Install the new O-ring  and reassemble caliper halves.

### CAUTION

Replace the O-ring with a new one.

- Apply THREAD LOCK SUPER "1360" to the caliper housing bolts and tighten them to the specified torque.

 99000-32130: THREAD LOCK SUPER "1360"

 Rear brake caliper housing bolt: 37 N·m  
(3.7kgf·m, 27.0 lb-ft)

### NOTE:

Completely clean up the thread of the caliper housing and housing bolts, before applying THREAD LOCK.

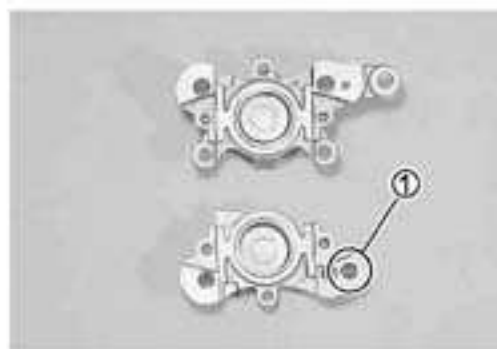
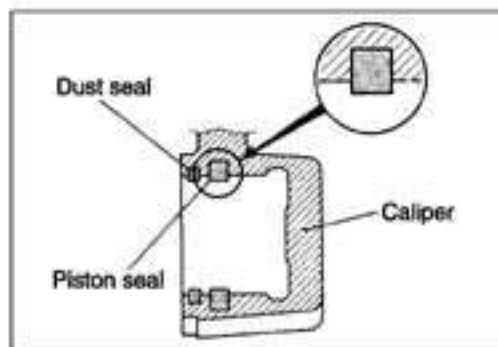
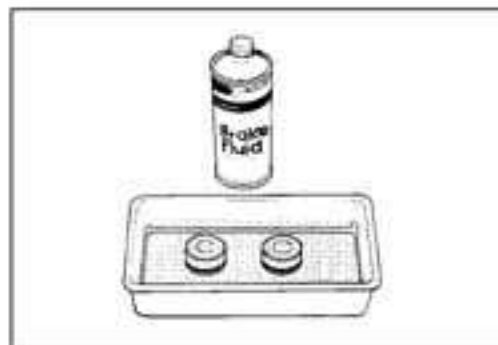

- Install the caliper to the caliper bracket and tighten each bolt to the specified torque.

- 🔧 **Rear brake caliper mounting bolt ①: 26 N·m  
(2.6 N·m, 19.0 lb-ft)**  
 Rear torque link nut ②: 34 N·m (3.4 kgf·m, 24.5 lb-ft)

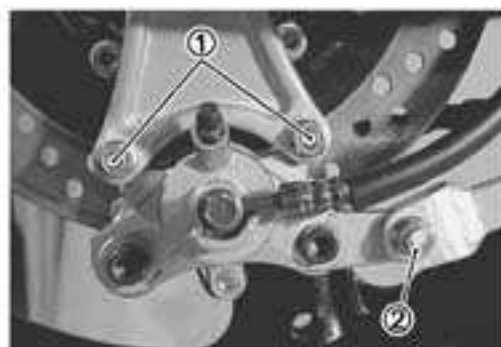

- Connect the rear brake hose to the rear brake caliper.
- Tighten the brake hose union bolt with the brake hose union pipe touching to the stopper of caliper.  
(Rear brake hose routing:  8-23)

- 🔧 **Brake hose union bolt: 23 N·m (2.3 kgf·m, 16.5 lb-ft)**

#### CAUTION

- The seal washers should be replaced by the new ones to prevent fluid leakage.
- Bleed air from the system after reassembling the caliper. ( 2-22)



## MASTER CYLINDER REMOVAL AND DISASSEMBLY

- Drain the brake fluid. ( 6-58)
- Remove the brake fluid reservoir tank mounting bolt ①.



- Place a rag underneath the union bolt on the master cylinder to catch spilled drops of brake fluid. Remove the union bolt ② and disconnect the brake hose.
- Disconnect the reservoir tank hose.

#### CAUTION

**Immediately and completely wipe off any brake fluid contacting any parts of the motorcycle. The fluid reacts chemically with paint, plastic and rubber materials, etc. and will damage them severely.**

- Loosen the lock nut ③.
- Remove the master cylinder mounting bolts ④.
- Remove the master cylinder by turning the master cylinder rod ⑤.

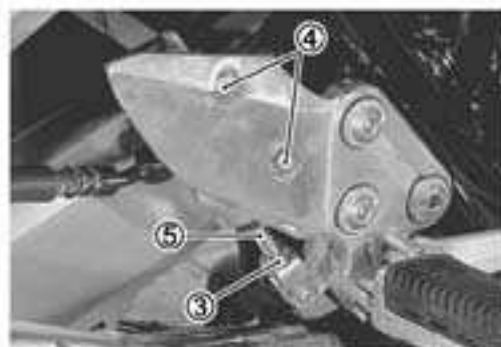

- Remove the reservoir cap and diaphragm.
- Remove the connector (6) by removing the circlip (7).
- Remove the O-ring (8).

 09900-06108: Snap ring pliers

#### CAUTION

Replace the O-ring with a new one.

- Pull out the dust seal (9), then remove the circlip (10) with the special tool.

 09900-06108: Snap ring pliers

- Remove the push rod, piston/primary cup and spring.

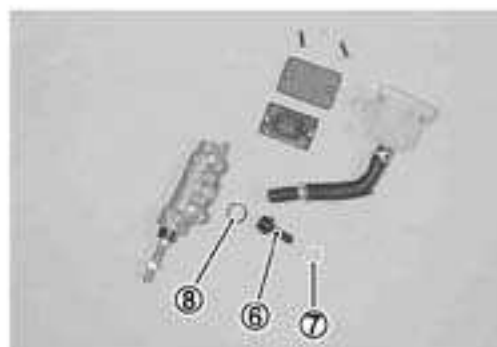

## MASTER CYLINDER INSPECTION

### CYLINDER, PISTON AND CUP SET

Inspect the cylinder bore wall for any scratches or other damage.  
Inspect the cup set and each rubber part for damage.

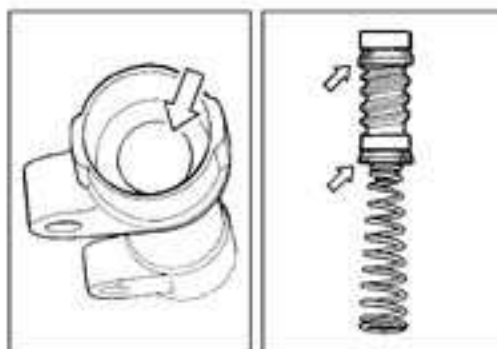

## MASTER CYLINDER REASSEMBLY AND REMOUNTING

Reassemble and remount the master cylinder in the reverse order of removal and disassembly. Pay attention to the following points:

#### CAUTION

- Wash the master cylinder components with fresh brake fluid before reassembly. Never use cleaning solvent or gasoline to wash them.
- Do not wipe the components with a rag.
- Apply brake fluid to the cylinder bore and all the component to be inserted into the bore.



 Specification and Classification: DOT 4

- Apply brake fluid to the piston/cup set.
- Install the following parts.
  - ① Piston/primary cup
  - ② Push rod
  - ③ Circlip
  - ④ Dust boot
- Apply the SUZUKI MOLY PASTE to the push rod.

 99000-25140: SUZUKI MOLY PASTE

 09900-06108: Snap ring pliers

- Install the master cylinder.
- Tighten the lock nut ②.

-  Rear master cylinder mounting bolt ①:  
10 N·m (1.0 kgf·m, 7.3 lb-ft)
- Rear master cylinder rod lock nut ②:  
18 N·m (1.8 kgf·m, 13.0 lb-ft)

- Connect the brake hose to the master cylinder.  
(Rear brake hose routing:  8-23)
- Tighten the brake hose union bolt ③ to the specified torque.

 Brake hose union bolt ③: 23 N·m (2.3 kgf·m, 16.5 lb-ft)

- Install the reservoir tank and reservoir tank hose.  
(Rear brake hose routing :  8-23)

#### CAUTION

- The seal washers should be replaced by the new ones to prevent fluid leakage.
- Bleed air from the system after reassembling the master cylinder. ( 2-22)

- Adjust the brake pedal height. ( 2-20)

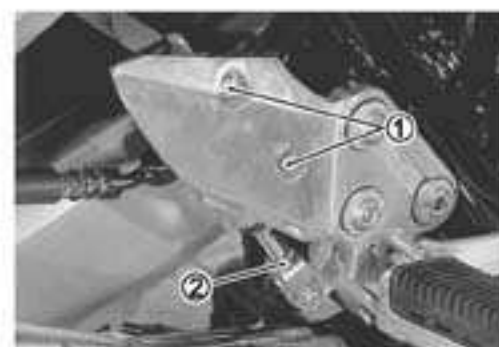
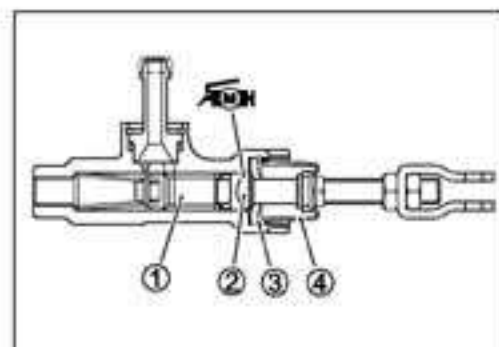

#### INSPECTION AFTER REASSEMBLY

Rear brake:  2-19

## CLUTCH RELEASE CYLINDER AND MASTER CYLINDER CONSTRUCTION

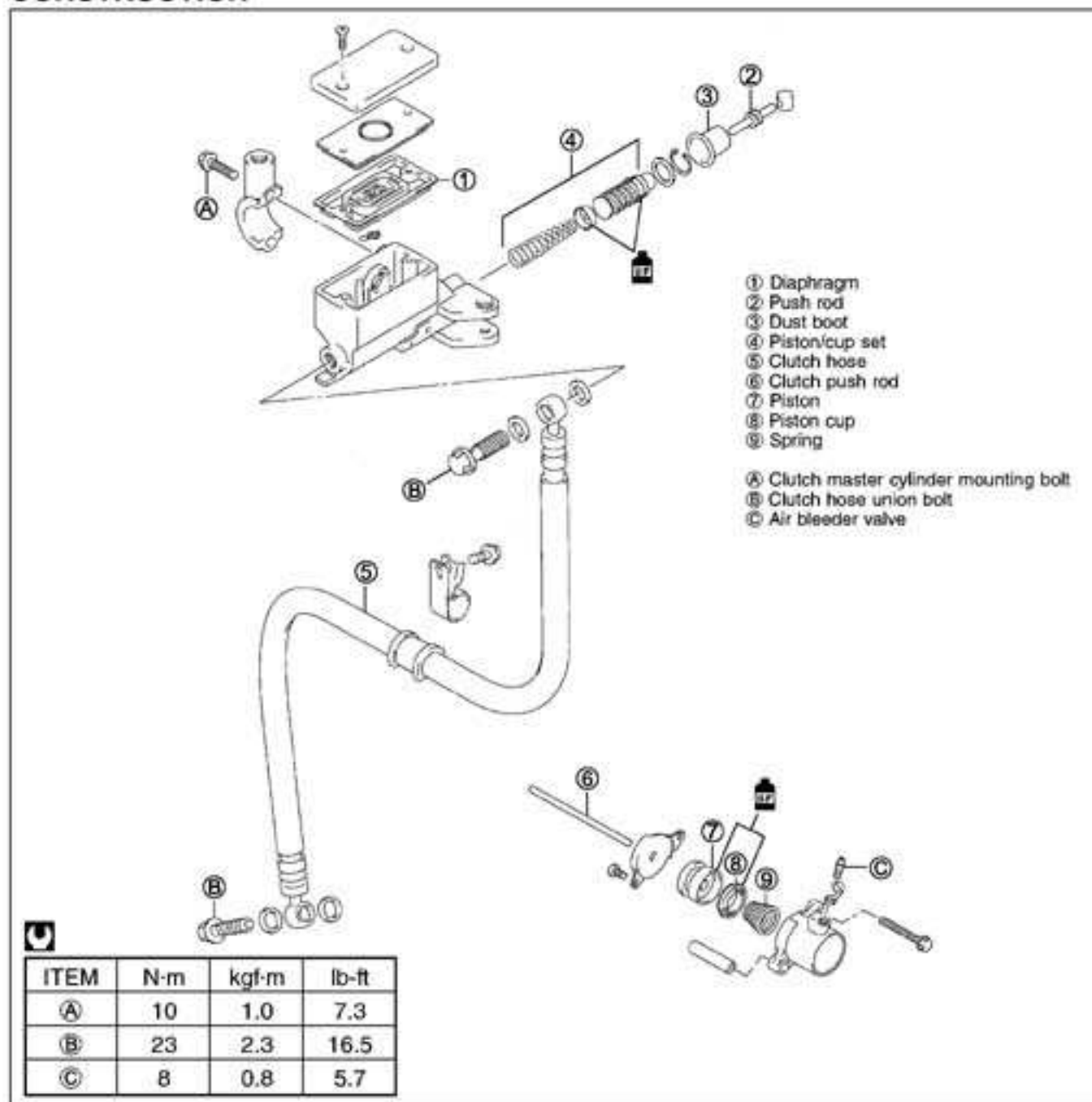

### ⚠ WARNING

- This clutch system is filled with an ethylene glycol-based DOT 4 brake fluid. Do not use or mix different types of fluid such as silicone-based or petroleum-based.
- Do not use any brake fluid taken from old, used or unsealed containers. Never reuse brake fluid left over from the last servicing or stored for long periods.
- When storing the brake fluid, seal the container completely and keep away from children.
- When replenishing brake fluid, take care not to get dust into fluid.
- When washing brake components, use fresh brake fluid. Never use cleaning solvent.

### CAUTION

Handle brake fluid with care: the fluid reacts chemically with paint, plastics, rubber materials etc. and will damage them severely.



## CLUTCH FLUID REPLACEMENT

- Place the motorcycle on a level surface and keep the handlebars straight.
- Remove the engine sprocket cover. (☞3-6)
- Remove the master cylinder reservoir cap and diaphragm.
- Suck up the old clutch fluid as much as possible from the reservoir tank.
- Fill the reservoir with the new clutch fluid.

### Specification and Classification: DOT 4

- Connect a clear hose to the clutch release cylinder air bleeder valve and insert the other end of hose into a receptacle.
- Loosen the air bleeder valve and pump the clutch lever until old clutch fluid flows out of the bleeder system.
- Close the clutch release cylinder air bleeder valve, and disconnect a clear hose. Fill the reservoir with fresh brake fluid to the upper level.

### CAUTION

**Bleed air in the clutch fluid system. (☞2-17)**

- Install the engine sprocket cover. (☞3-9)



## CLUTCH RELEASE CYLINDER REMOVAL AND DISASSEMBLY

- Drain the clutch fluid. (☞above)
- Disconnect the clutch hose by removing the union bolt ①.

### NOTE:

*Completely wipe off any clutch fluid adhering to any part of motorcycle.*

*The fluid reacts chemically with paint, plastics, rubber materials, etc.*

- Remove the air bleeder valve ②.
- Remove the clutch release cylinder housing ③.
- Remove the clutch release cylinder by removing the bolts ④ and screws ⑤.

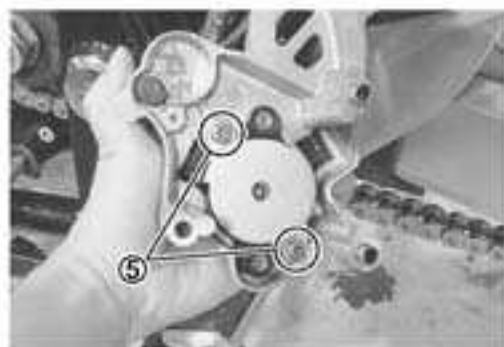
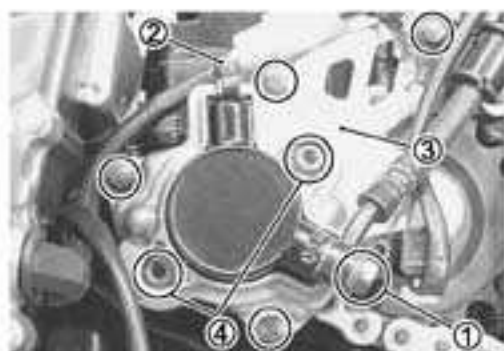



- Place a rag over the piston to prevent it from popping out. Force out the piston by using compressed air.

**CAUTION**

Do not use high pressure air to prevent piston damage.

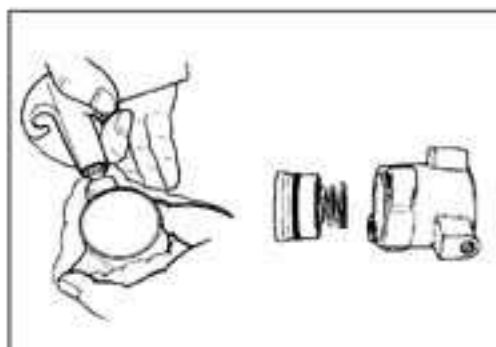
**CLUTCH RELEASE CYLINDER INSPECTION**

Inspect the clutch release cylinder bore wall for nicks, scratches or other damage. Inspect the oil seal for damage and wear. Inspect the piston surface for any scratches or other damage.

**CLUTCH RELEASE CYLINDER REASSEMBLY AND REMOUNTING**

Reassemble the clutch release cylinder in the reverse order of disassembly and by taking the following steps:

**CAUTION**

- Wash the clutch cylinder components with fresh brake fluid before reassembly. Never use cleaning solvent or gasoline to wash them.
- Do not wipe the components with a rag.
- Apply brake fluid to the cylinder bore and piston to be inserted into the bore.

**Specification and Classification: DOT 4**

- ① Clutch release cylinder retainer
- ② Piston
- ③ Piston cup
- ④ Spring
- ⑤ Air bleeder valve
- ⑥ Bleeder cap
- ⑦ Clutch release cylinder body
- ⑧ Push rod

- Apply grease to the clutch push rod ⑧.

 99000-25010: SUZUKI SUPER GREASE "A"

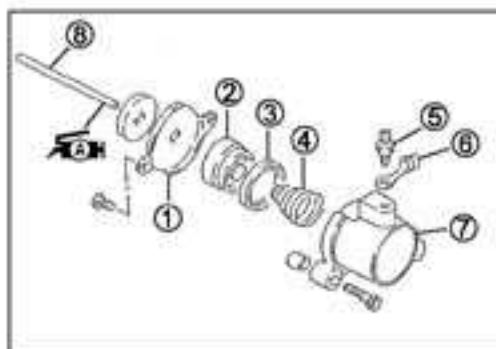

- Tighten each bolts to the specified torque.

- **Clutch hose union bolt ①: 23 N·m (2.3 kgf·m, 16.5 lb-ft)**  
**Air bleeder valve ②: 8.0 N·m (0.8 kgf·m, 6.0 lb-ft)**

#### CAUTION

- The seal washers should be replaced by the new ones to prevent fluid leakage.
- Bleed air from the system after reassembling the release cylinder. (☞2-17)



## CLUTCH MASTER CYLINDER REMOVAL AND DISASSEMBLY

- Drain the clutch fluid. (☞6-65)
- Disconnect the clutch lever position switch lead wires.
- Place a rag underneath the union bolt on the master cylinder to catch spilled drops of brake fluid. Remove the union bolt and disconnect the clutch hose from the master cylinder.

#### CAUTION

Completely wipe off any brake fluid adhering to any parts of motorcycle. The fluid reacts chemically with paint, plastics, rubber materials, etc. and will damage them severely.

- Remove the clutch master cylinder.



- Remove the clutch lever ① and clutch lever position switch.

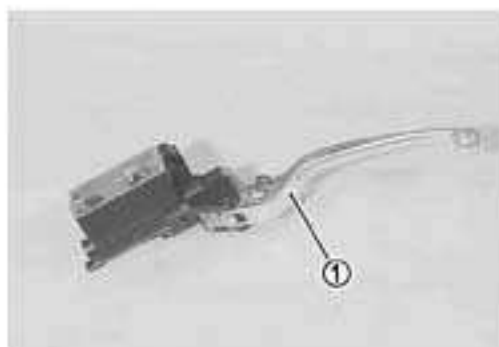

- Remove the boot ② and push rod ③.
- Remove the circlip ④ with snap ring pliers.

 09900-06108: Snap ring pliers

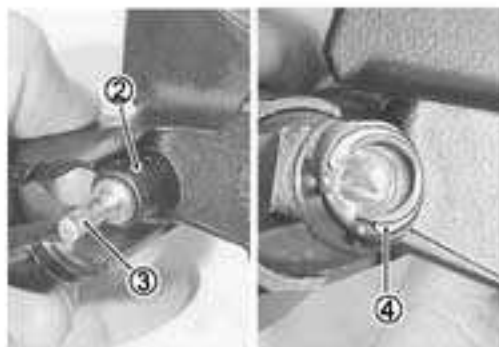

- Remove the piston/cup set
  - ⑤ Secondary cup
  - ⑥ Piston
  - ⑦ Primary cup
  - ⑧ Spring

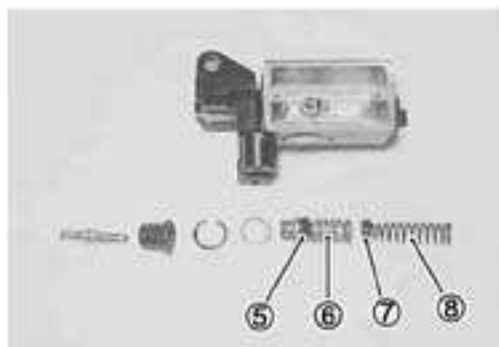

## CLUTCH MASTER CYLINDER INSPECTION

Inspect the master cylinder bore for any scratches or other damage.

Inspect the piston surface for any scratches or other damage.

Inspect the primary cup, secondary cup and dust seal for wear or damage.

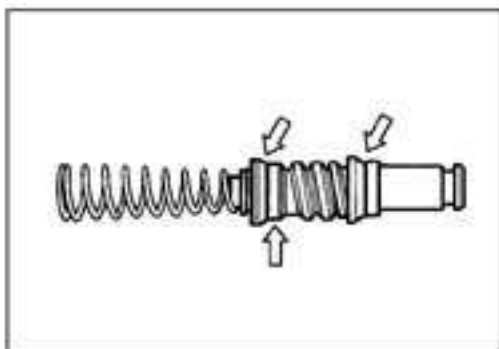

## CLUTCH MASTER CYLINDER REASSEMBLY AND REMOUNTING

Reassemble the master cylinder in the reverse order of removal and disassembly. Pay attention to the following points:

### CAUTION

- Wash the master cylinder components with fresh brake fluid before reassembly. Never use cleaning solvent or gasoline to wash them.
- Do not wipe the components with a rag.
- Apply brake fluid to the cylinder bore and all the component to be inserted into the bore.

### Specification and Classification: DOT 4

- Apply brake fluid to the piston/cup set and install them to the clutch master cylinder.
  - ① Spring
  - ② Primary cup
  - ③ Piston
  - ④ Secondary cup
  - ⑤ Stopper plate
  - ⑥ Circlip
  - ⑦ Dust boot
  - ⑧ Push rod

- Apply SUZUKI MOLY PASTE to the push rod.
- Install the push rod and dust boot.

### 99000-25140: SUZUKI MOLY PASTE

- When remounting the master cylinder on the handlebars, align the master cylinder holder's mating surface (A) with punched mark (B) on the handlebars and tighten the upper clamp bolt first as shown.

### Clutch master cylinder mounting bolt:

10 N·m (1.0 kgf·m, 7.3 lb-ft)

Clutch master cylinder union bolt: 23 N·m

(2.3 kgf·m, 16.5 lb-ft)

- Connect the clutch lever position switch lead wire.

### CAUTION

- The seal washers should be replaced by the new ones to prevent fluid leakage.
- Bleed air from the system after reassembling the master cylinder. (2-17)

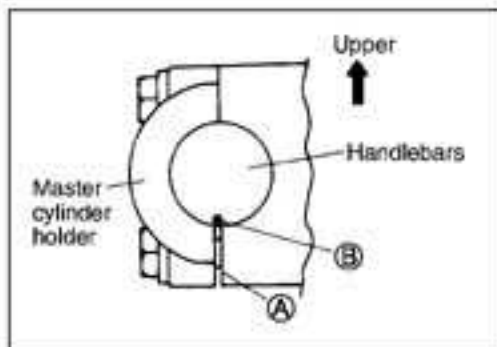
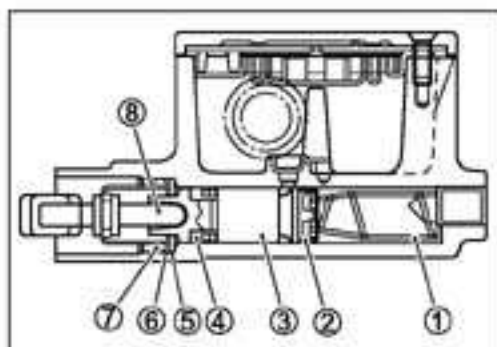

## TIRE AND WHEEL

### TIRE REMOVAL

The most critical factor of a tubeless tire is the seal between the wheel rim and the tire bead. For this reason, it is recommended to use a tire changer that can satisfy this sealing requirement and can make the operation efficient as well as functional.

For operating procedures, refer to the instructions supplied by the tire changer manufacturer.

#### NOTE:

*When removing the tire in the case of repair or inspection, mark the tire with a chalk to indicate the tire position relative to the valve position.*

*Even though the tire is refitted to the original position after repairing a puncture, the tire may have to be balanced again since such a repair can cause imbalance.*

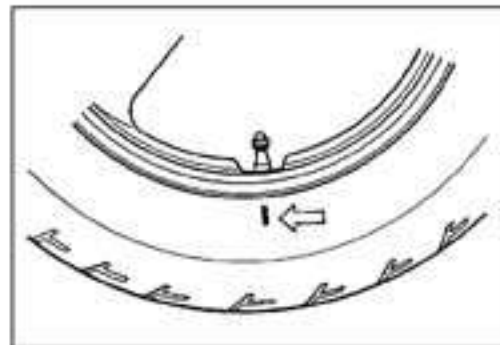

### INSPECTION

#### WHEEL

Wipe the wheel clean and check for the following:

- \* Distortion and crack
- \* Any flaws and scratches at the bead seating area.
- \* Wheel rim runout (☞ 6-7)



#### TIRE

Tire must be checked for the following points:

- \* Nick and rupture on side wall
- \* Tire tread depth (☞ 2-22)
- \* Tread separation
- \* Abnormal, uneven wear on tread
- \* Surface damage on bead
- \* Localized tread wear due to skidding (Flat spot)
- \* Abnormal condition of inner liner

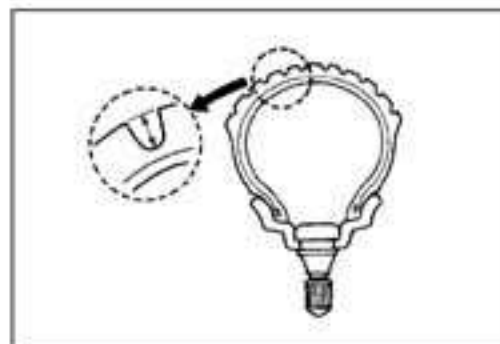

**VALVE**

- Inspect the valve after the tire is removed from the rim. Replace the valve with a new one if the seal rubber is peeling or has damage.
- Inspect the valve core. If the seal has abnormal deformation, replace the valve with a new one.

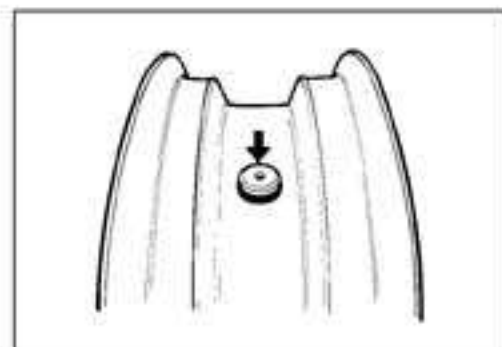
**VALVE INSTALLATION**

- Any dust or rust around the valve hole must be cleaned off. Then install the valve in the rim.

**NOTE:**

To properly install the valve into the valve hole, apply a special tire lubricant or neutral soapy liquid to the valve.

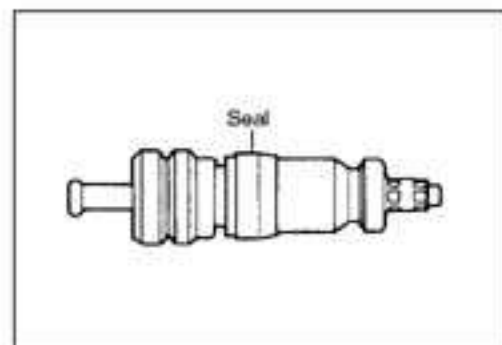
**CAUTION**

Be careful not to damage the lip of valve.

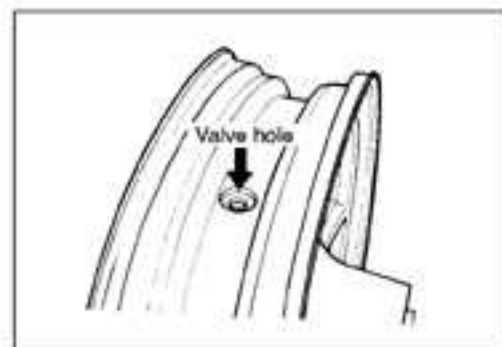
**TIRE INSTALLATION**

- Apply tire lubricant to the tire bead.
- When installing the tire onto the wheel, observe the following points.

**CAUTION**

- Do not reuse the valve which has been once removed.
- Never use oil, grease or gasoline on the tire bead in place of tire lubricant.

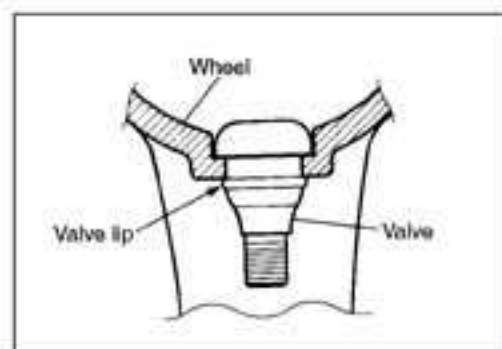

- When installing the tire, the arrow ① on the side wall should point to the direction of wheel rotation.
- Align the chalk mark put on the tire at the time of removal with the valve position.

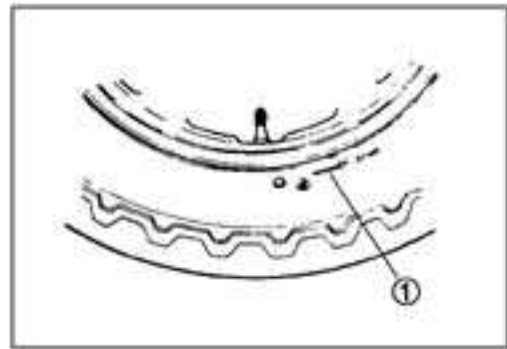

- For installation procedure of tire onto the wheel, follow the instructions given by the tire changer manufacturer.
- Bounce the tire several times while rotating. This makes the tire bead expand outward to contact the wheel, thereby facilitating air inflation.
- Inflate the tire.

#### ⚠ WARNING

- Do not inflate the tire to more than 400 kPa (4.0kgf/cm<sup>2</sup>). If inflated beyond this limit, the tire can burst and possibly cause injury. Do not stand directly over the tire while inflating.
- In the case of preset pressure air inflator, pay special care for the set pressure adjustment.

- In this condition, check the "rim line" cast on the tire side walls. The line must be equidistant from the wheel rim all around. If the distance between the rim line and wheel rim varies, this indicates that the bead is not properly seated. If this is the case, deflate the tire completely and unseat the bead for both sides. Coat the bead with lubricant and fit the tire again.
- When the bead has been fitted properly, adjust the pressure to specification.
- As necessary, adjust the tire balance.

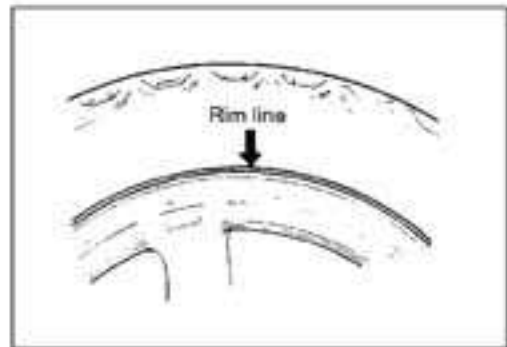

#### CAUTION

Do not run with a repaired tire at a high speed.

#### DATA Tire pressure

- Solo riding: Front: 250 kPa (2.50 kgf/cm<sup>2</sup>, 36 psi)  
 Rear: 250 kPa (2.50 kgf/cm<sup>2</sup>, 36 psi)
- Dual riding: Front: 250 kPa (2.50 kgf/cm<sup>2</sup>, 36 psi)  
 Rear: 290 kPa (2.90 kgf/cm<sup>2</sup>, 42 psi)



**ELECTRICAL SYSTEM****CONTENTS**

<b>CAUTIONS IN SERVICING .....</b>	<b>7- 2</b>
<b>LOCATION OF ELECTRICAL COMPONENTS .....</b>	<b>7- 4</b>
<b>CHARGING SYSTEM .....</b>	<b>7- 6</b>
<b>TROUBLESHOOTING .....</b>	<b>7- 6</b>
<b>INSPECTION .....</b>	<b>7- 7</b>
<b>STARTER SYSTEM AND SIDE-STAND/IGNITION</b>	
<b>INTERLOCK SYSTEM .....</b>	<b>7-11</b>
<b>TROUBLESHOOTING .....</b>	<b>7-11</b>
<b>STARTER MOTOR REMOVAL AND DISASSEMBLY .....</b>	<b>7-12</b>
<b>STARTER MOTOR INSPECTION .....</b>	<b>7-13</b>
<b>STARTER MOTOR REASSEMBLY .....</b>	<b>7-13</b>
<b>STARTER RELAY INSPECTION .....</b>	<b>7-14</b>
<b>SIDE-STAND/IGNITION INTERLOCK SYSTEM PARTS</b>	
<b>INSPECTION .....</b>	<b>7-15</b>
<b>IGNITION SYSTEM .....</b>	<b>7-18</b>
<b>TROUBLESHOOTING .....</b>	<b>7-18</b>
<b>INSPECTION .....</b>	<b>7-20</b>
<b>COMBINATION METER .....</b>	<b>7-23</b>
<b>REMOVAL AND DISASSEMBLY .....</b>	<b>7-23</b>
<b>INSPECTION .....</b>	<b>7-24</b>
<b>LAMPS .....</b>	<b>7-28</b>
<b>RELAYS .....</b>	<b>7-29</b>
<b>SWITCHES .....</b>	<b>7-29</b>
<b>BATTERY .....</b>	<b>7-31</b>
<b>SPECIFICATIONS .....</b>	<b>7-31</b>
<b>INITIAL CHARGING .....</b>	<b>7-31</b>
<b>SERVICING .....</b>	<b>7-32</b>
<b>RECHARGING OPERATION .....</b>	<b>7-33</b>

## CAUTIONS IN SERVICING

### CONNECTOR

- When connecting a connector, be sure to push it in until a click is felt.
- Inspect the connector for corrosion, contamination and breakage in its cover.

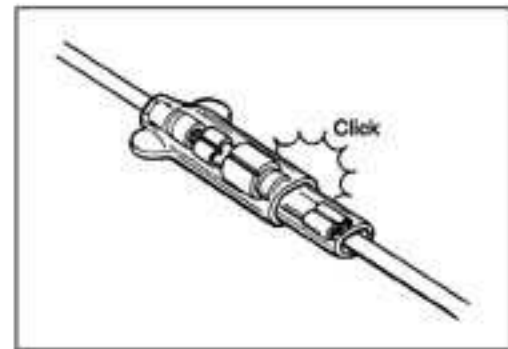

### COUPLER

- With a lock type coupler, be sure to release the lock before disconnecting it and push it in fully till the lock works when connecting it.
- When disconnecting the coupler, be sure to hold the coupler itself and do not pull the lead wires.
- Inspect each terminal on the coupler for being loose or bent.
- Inspect each terminal for corrosion and contamination.

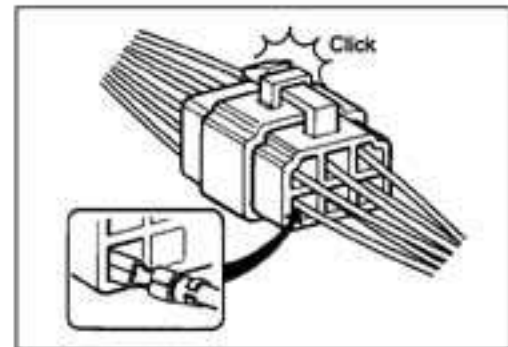

### CLAMP

- Clamp the wire harness at such positions as indicated in "WIRE HARNESS ROUTING". (☞ 8-16 to 8-18)
- Bend the clamp properly so that the wire harness is clamped securely.
- In clamping the wire harness, use care not to allow it to hang down.
- Do not use wire or any other substitute for the band type clamp.

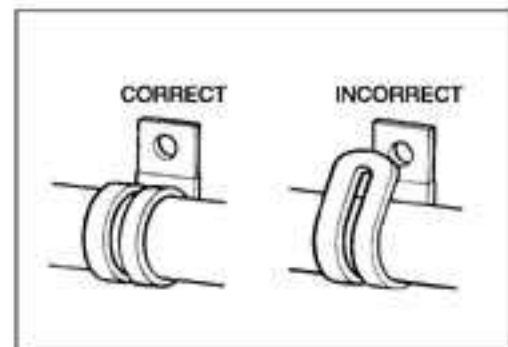

### FUSE

- When a fuse blows, always investigate the cause, correct it and then replace the fuse.
- Do not use a fuse of a different capacity.
- Do not use wire or any other substitute for the fuse.

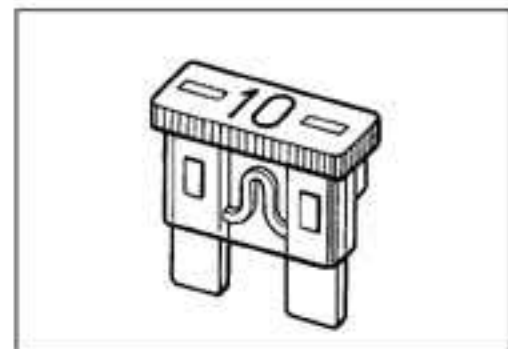

### SEMI-CONDUCTOR EQUIPPED PART

- Be careful not to drop the part with a semi-conductor built in such as a ECM.
- When inspecting this part, follow inspection instruction strictly. Neglecting proper procedure may cause damage to this part.

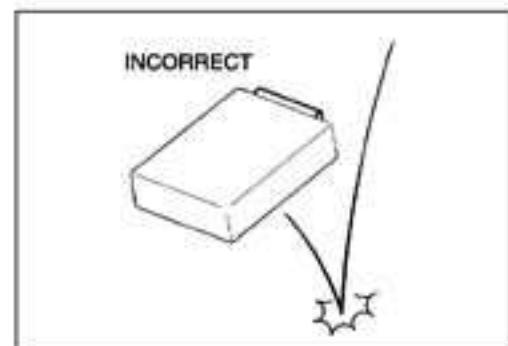

## BATTERY

- The MF battery used in this motorcycle does not require maintenance (e.g., electrolyte level inspection, distilled water replenishment).
- During normal charging, no hydrogen gas is produced. However, if the battery is overcharged, hydrogen gas may be produced. Therefore, be sure there are no fire or spark sources (e.g., short circuit) nearby when charging the battery.
- Be sure to recharge the battery in a well-ventilated and open area.
- Note that the charging system for the MF battery is different from that of a conventional battery. Do not replace the MF battery with a conventional battery.

## CONNECTING THE BATTERY

- When disconnecting terminals from the battery for disassembly or servicing, be sure to disconnect the  $\ominus$  battery lead wire, first.
- When connecting the battery lead wires, be sure to connect the  $\oplus$  battery lead wire, first.
- If the terminal is corroded, remove the battery, pour warm water over it and clean it with a wire brush.
- After connecting the battery, apply a light coat of grease to the battery terminals.
- Install the cover over the  $\oplus$  battery terminal.

## WIRING PROCEDURE

- Properly route the wire harness according to the "WIRE ROUTING" section. (8-16 to 8-18)

## USING THE MULTI CIRCUIT TESTER

- Properly use the multi circuit tester  $\oplus$  and  $\ominus$  probes. Improper use can cause damage to the motorcycle and tester.
- If the voltage and current values are not known, begin measuring in the highest range.
- When measuring the resistance, make sure that no voltage is applied. If voltage is applied, the tester will be damaged.
- After using the tester, be sure to turn the switch to the OFF position.

### CAUTION

Before using the multi circuit tester, read its instruction manual.

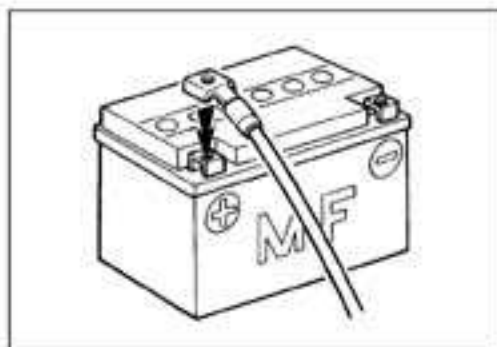
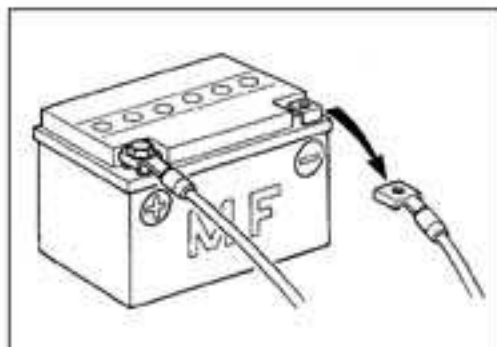

## LOCATION OF ELECTRICAL COMPONENTS

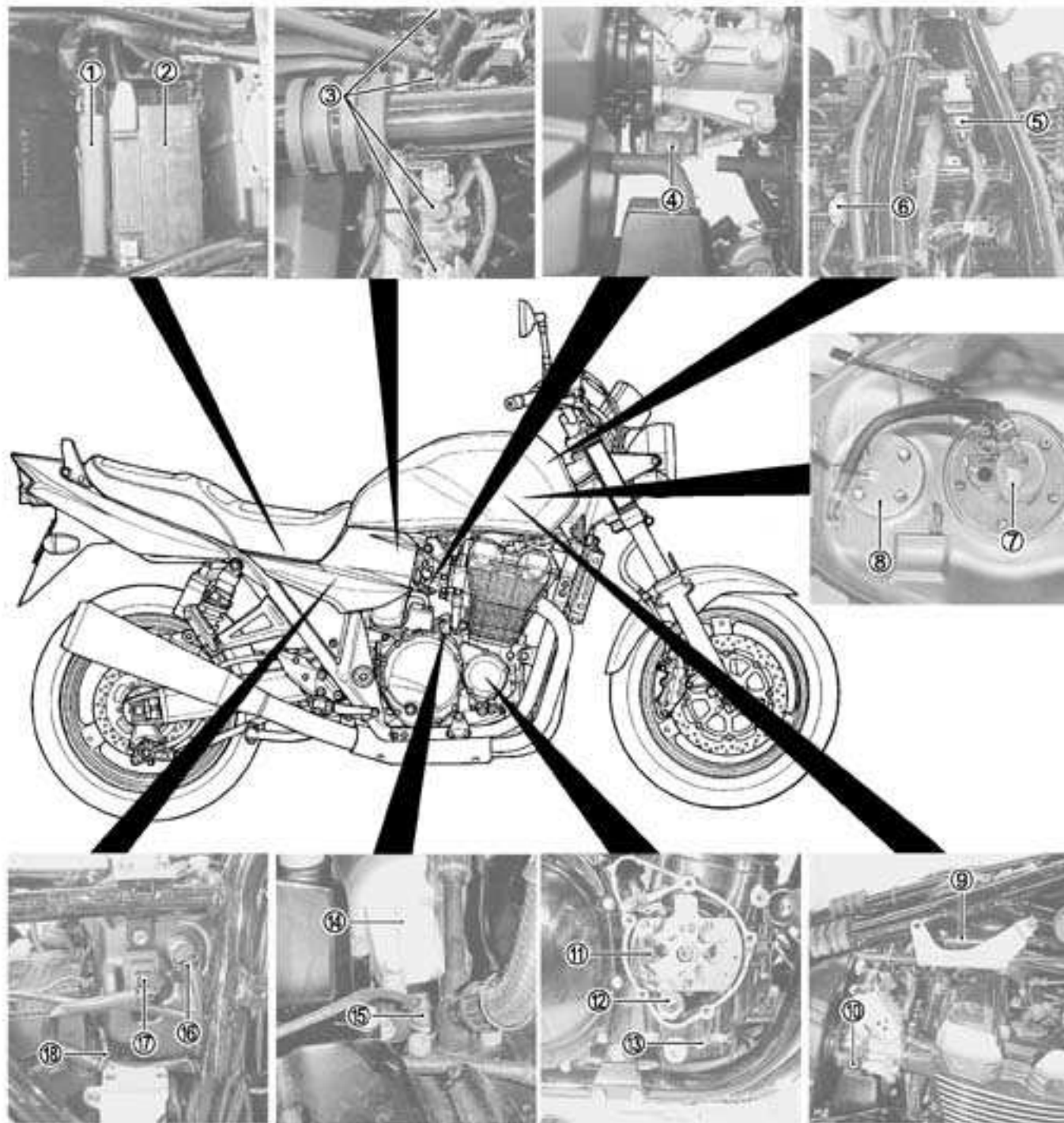

① ECM (Engine Control Module)

② Battery

③ Fuel injector (☞4-46)

④ Actuator (☞4-42)

⑤ Intake air pressure sensor (☞4-33)

⑥ Cam position sensor (☞4-31)

⑦ Fuel pump (☞4-50)

⑧ Fuel level gauge

⑨ Ignition coil (No. 2 & 3)

⑩ Secondary throttle position sensor (☞4-43)

⑪ CKP sensor

⑫ Oil pressure switch

⑬ Fan motor switch (☞5-10)

⑭ Starter motor

⑮ Oil temp. sensor (☞5-11)

⑯ Intake air temp. sensor (☞4-38)

⑰ Air pressure sensor (☞4-39)

⑱ Tip over sensor (☞4-41)

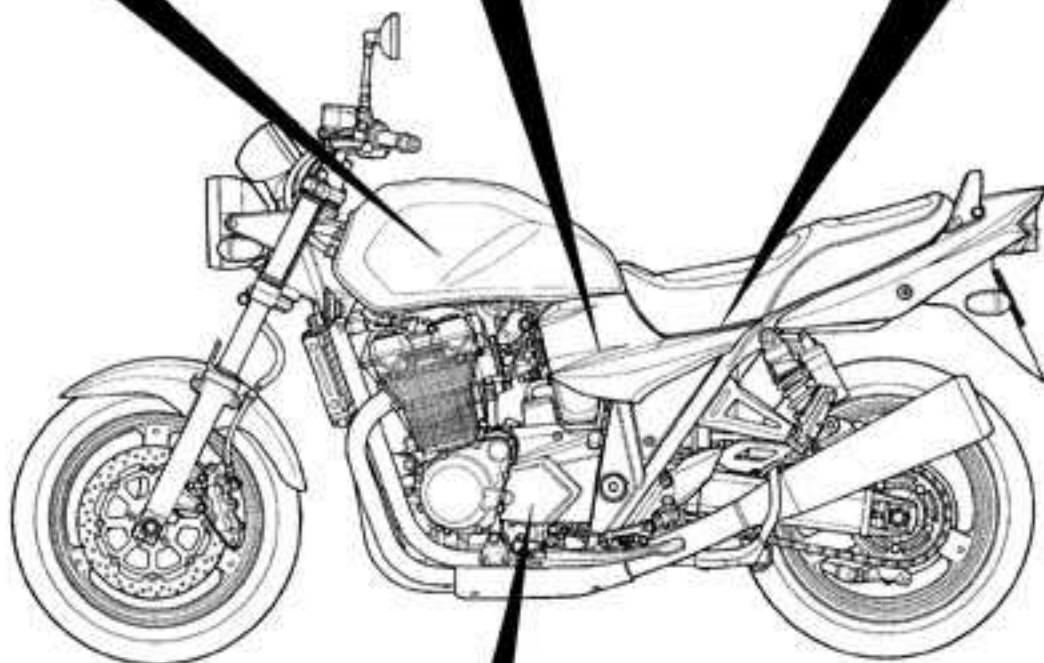
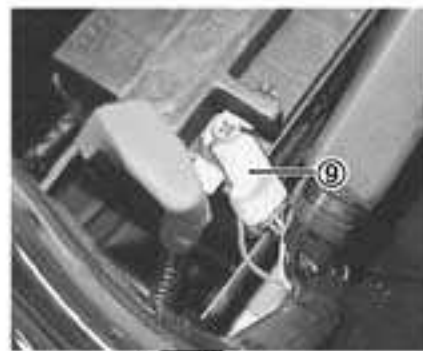
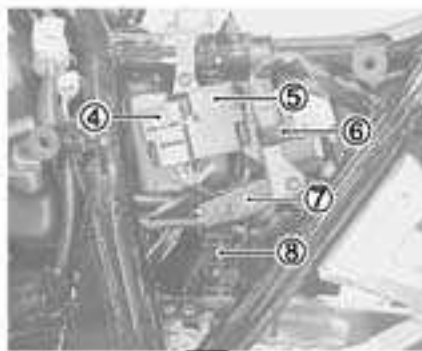
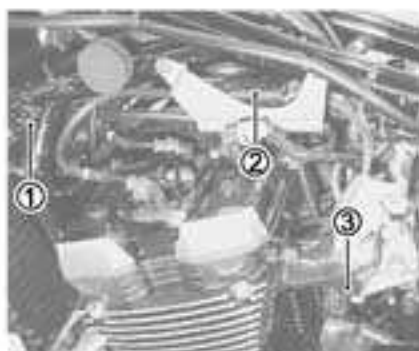

- ① Cooling fan
- ② Ignition coil (No. 1 & 4)
- ③ Throttle position sensor
- ④ Fuse box
- ⑤ Side-stand/turn signal relay
- ⑥ Starter relay
- ⑦ Fuel pump relay
- ⑧ Regulator/rectifier
- ⑨ Mode selection switch coupler

- ⑩ Generator
- ⑪ Side-stand switch
- ⑫ Gear position switch
- ⑬ Speedometer sensor

## CHARGING SYSTEM

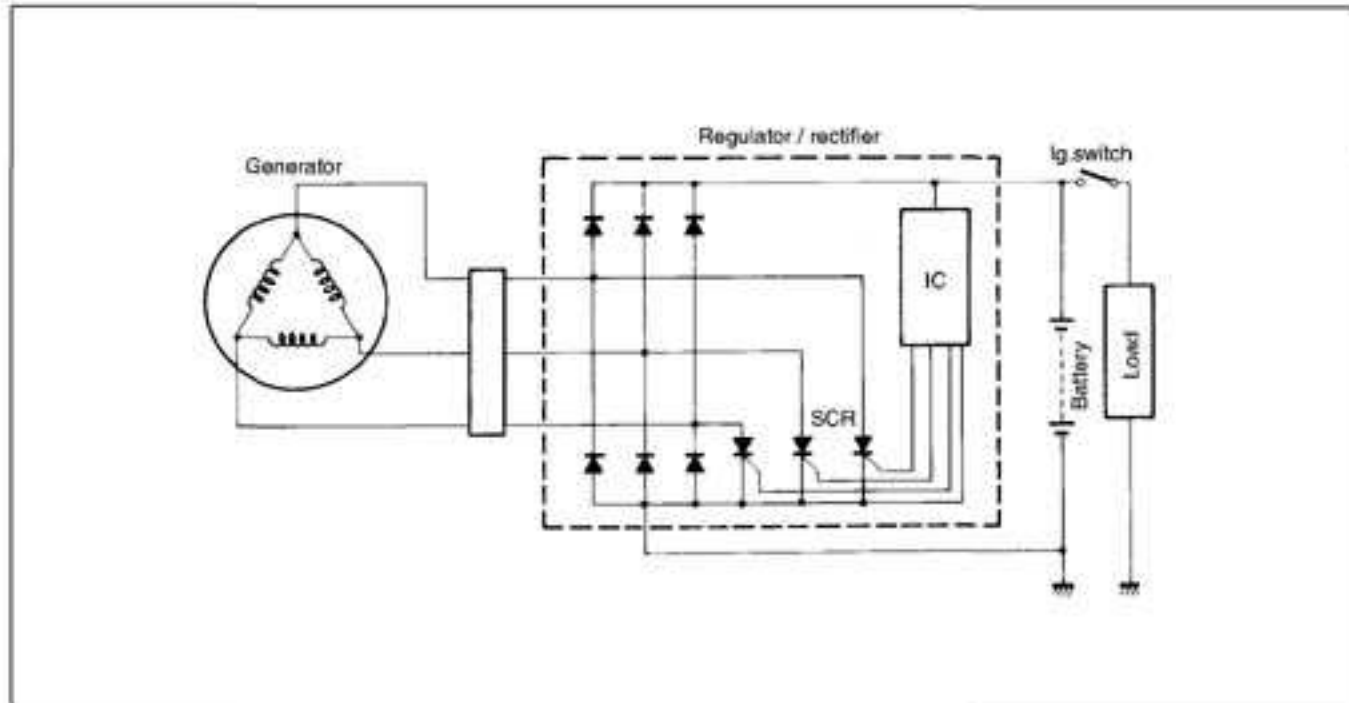

## TROUBLESHOOTING

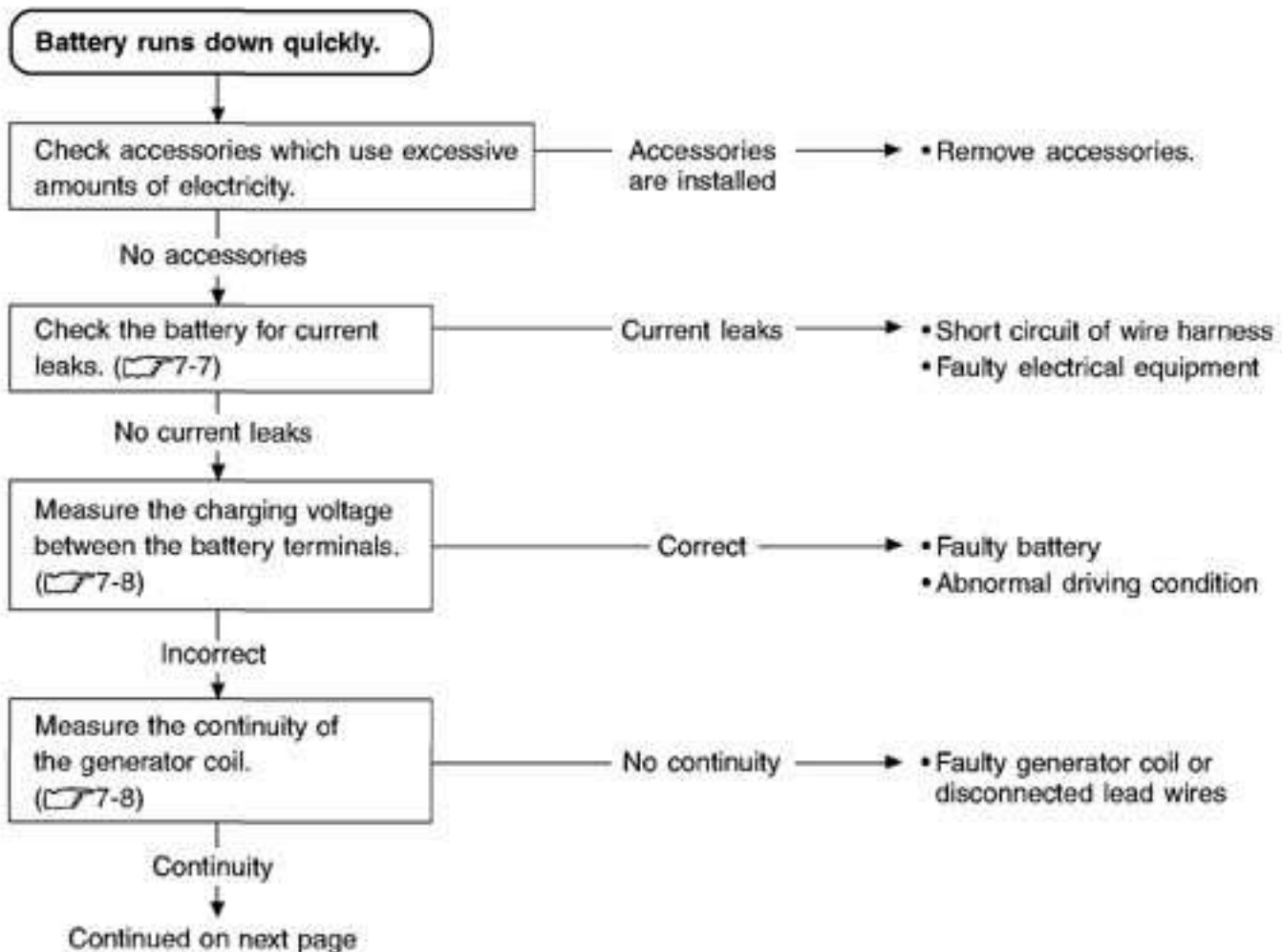



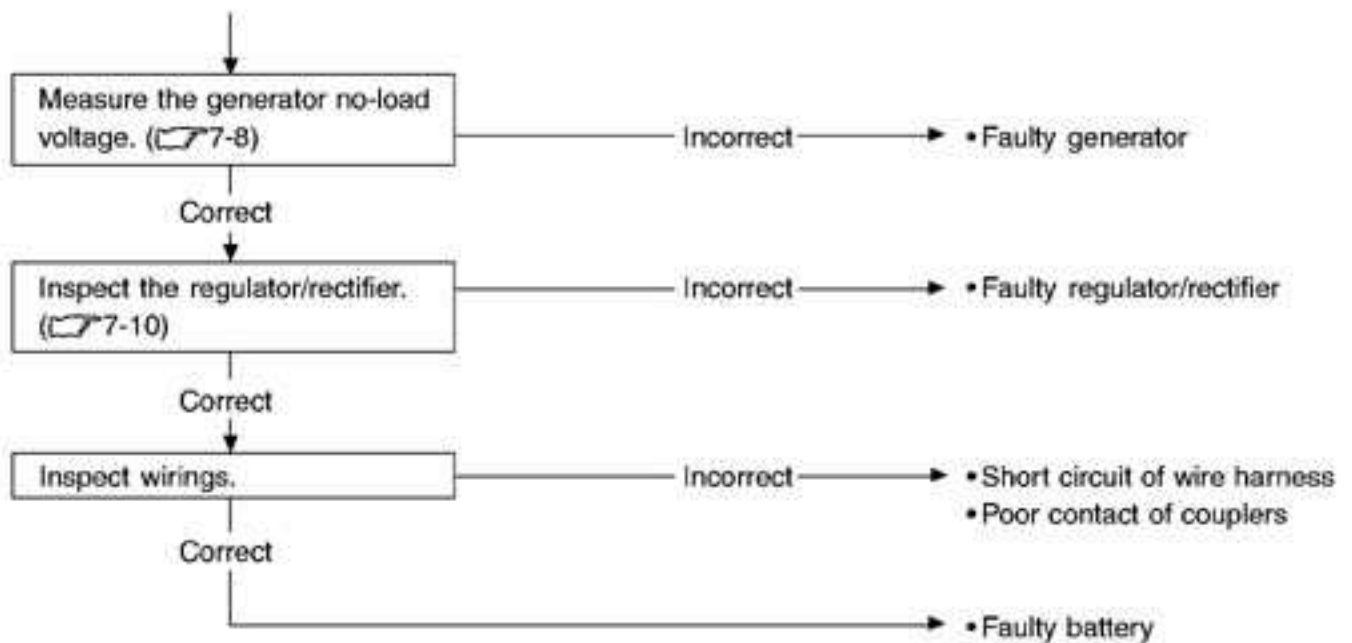

### Others

Battery overcharge	<ul style="list-style-type: none"> <li>Faulty regulator/rectifier</li> <li>Faulty battery</li> <li>Poor contact of generator lead wire coupler</li> </ul>
--------------------	---

## INSPECTION

### BATTERY CURRENT LEAKAGE

- Remove the seat. (6-3)
- Remove the tray.
- Turn the ignition switch to the OFF position.
- Disconnect the battery  $\ominus$  lead wire.

Measure the current between  $\ominus$  battery terminal and the  $\ominus$  battery lead wire using the multi circuit tester. If the reading exceeds the specified value, leakage is evident.

**TOOL** 09900-25008: Multi circuit tester set

**DATA** Battery current (leak): Under 3 mA

**TESTER** Tester knob indication: Current (---, 20 mA)

### CAUTION

- Because the current leak might be large, turn the tester to high range first to avoid tester damage.
- Do not turn the ignition switch to the "ON" position when measuring current.

When checking to find the excessive current leakage, remove the couplers and connectors, one by one, checking each part.

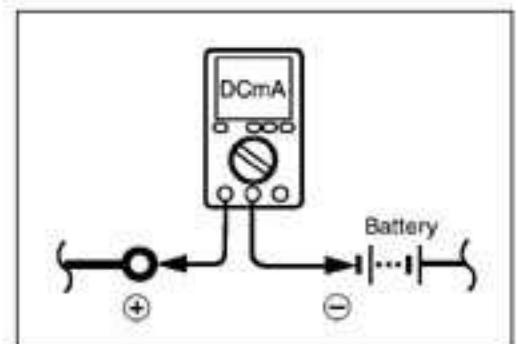



**REGULATED VOLTAGE**

- Remove the seat. (☞6-3)
- Remove the tray.
- Start the engine and keep it running at 5 000 r/min. with lighting switch turned ON (except for E-24) and dimmer switch turned HI position.

Measure the DC voltage between the ⊕ and ⊖ battery terminals using the multi circuit tester. If the voltage is not within the specified value, inspect the generator and regulator/rectifier. (☞7-8 and 7-10)

**NOTE:**

When making this test, be sure that the battery is in fully-charged condition.

 09900-25008: Multi circuit tester set

 Tester knob indication: Voltage (V)

**DATA** Charging output (Regulated voltage):  
14.0 – 15.5 V at 5 000 r/min.

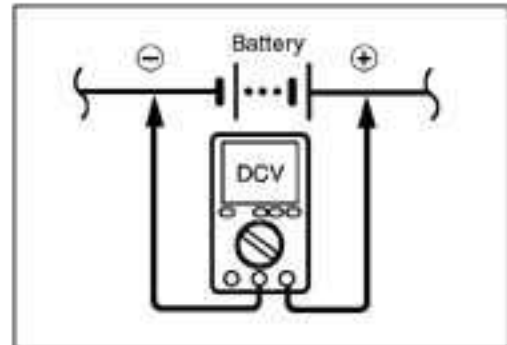
**GENERATOR COIL RESISTANCE**

- Remove the engine sprocket outer cover.
- Disconnect the generator coupler.

Measure the resistance between the three lead wires.

If the resistance is not specified value, replace the stator with a new one. Also, check that the generator core is insulated.

 09900-25008: Multi circuit tester set

 Tester knob indication: Resistance (Ω)

**DATA** Generator coil resistance: 0.2 – 1.0 Ω (Yellow – Yellow)  
∞ Ω (Yellow – Ground)

**NOTE:**

When making above test, it is not necessary to remove the generator.

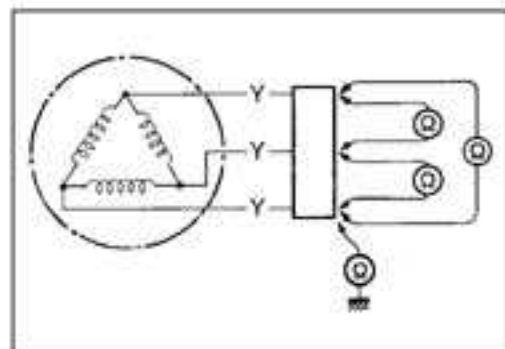
**GENERATOR NO-LOAD PERFORMANCE**

- Start the engine and keep it running at 5 000 r/min.
- Using the multi circuit tester, measure the voltage between three lead wires.
- If the tester reads under the specified value, replace the generator with a new one.

 09900-25008: Multi circuit tester set

 Tester knob indication: Voltage (V)

**DATA** Generator no-load performance:  
More than 60 V at 5 000 r/min (When engine is cold)

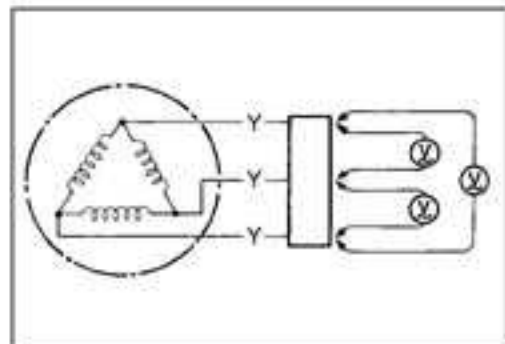

**REGULATOR/RECTIFIER**

- Remove the seat. (6-3)
- Remove the tray.
- Remove the battery.

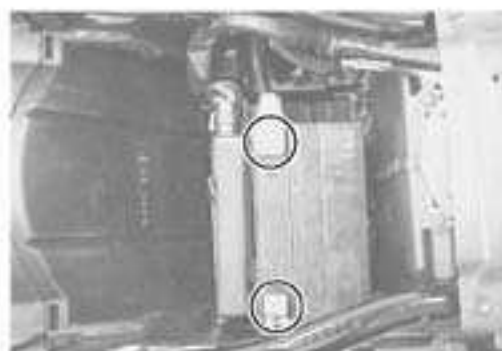

- Disconnect the seat lock cable ① and brake light/taillight coupler ②.

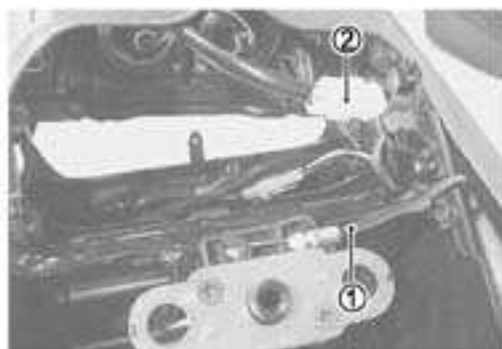

- Remove the pillion rider gripe ③ and seat tail cover ④.

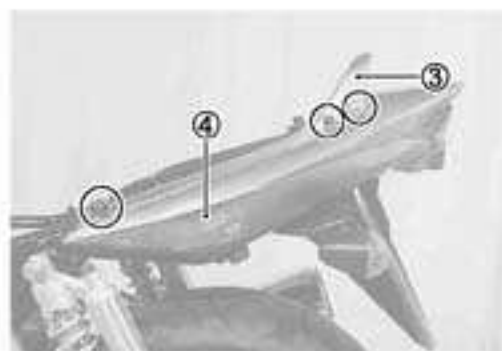

- Disconnect the rear turn signal light couplers (right and left).



- Remove the rear fender mounting bolts.



- Move the rear fender backward.
- Remove the regulator/rectifier.



Measure the voltage between the terminals using the multi circuit tester as indicated in the table below. If the voltage is not within the specified value, replace the regulator/rectifier with a new one.

 09900-25008: Multi circuit tester set

 Tester knob indication: Diode test (↔)

Unit: V

Probe of tester to:	⊕ Probe of tester to:					
	A	B	C	D	E	F
A		*	0.4 - 0.7	0.3 - 0.6	0.3 - 0.6	0.3 - 0.6
B	*		*	*	*	*
C	*	*		*	*	*
D	*	*	0.3 - 0.6		*	*
E	*	*	0.3 - 0.6	*		*
F	*	*	0.3 - 0.6	*	*	

\* More than 1.4 V (tester's battery voltage)

**NOTE:**

If the tester reads under 1.4 V when the tester probes are not connected, replace the battery of multi circuit tester.

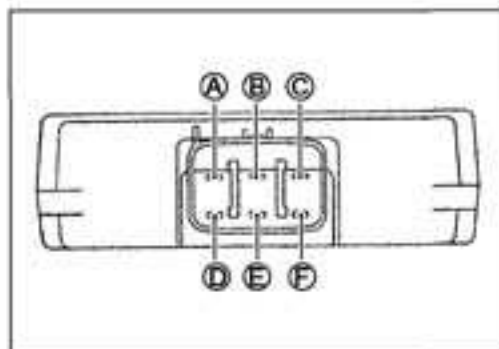

## STARTER SYSTEM AND SIDE-STAND/IGNITION INTERLOCK SYSTEM

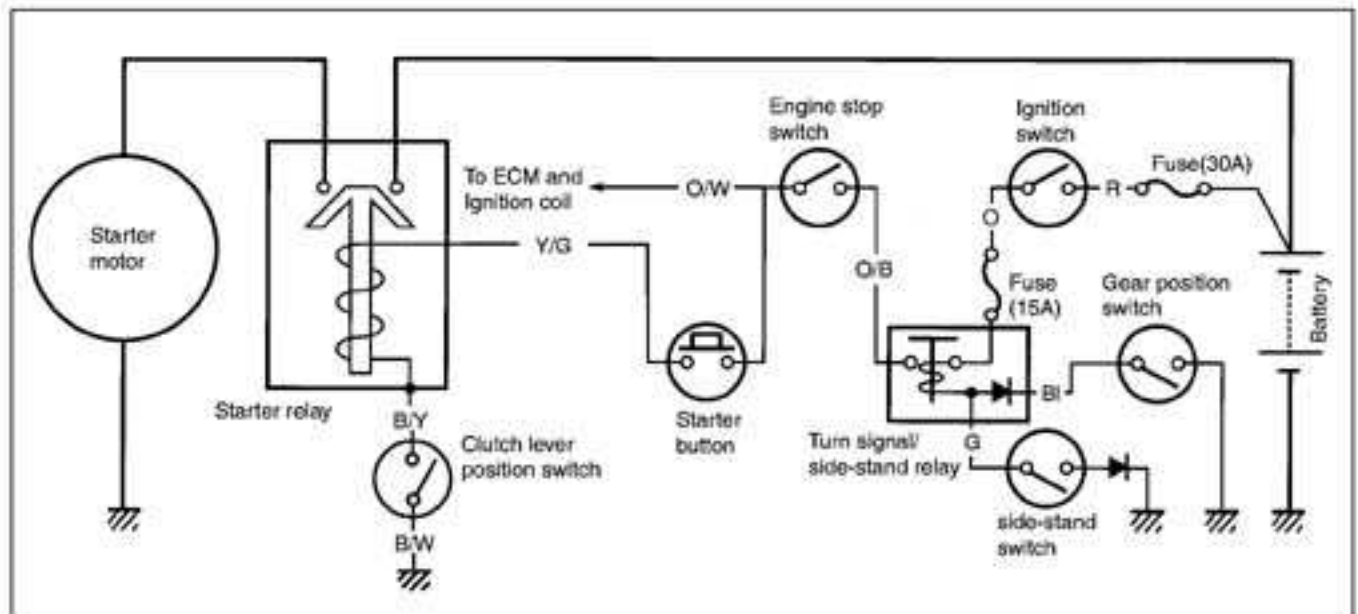

### TROUBLESHOOTING

#### Starter motor will not run.

The transmission is in neutral. Grasp the clutch lever, turn on the ignition switch with the engine stop switch in the "RUN" position and listen for a click from the starter relay when the starter button is pushed.

No click

Measure the starter relay voltage at the starter relay connectors (between Y/G  $\oplus$  and B/Y  $\ominus$ ) when the starter button is pushed.

Voltage

Continued on next page

Clicks

Check if the starter motor runs when its terminal is connected to the battery  $\oplus$  terminal (Do not use thin "wire" because a large amount of current flows)

Runs

Does not run

• Faulty starter motor

• Faulty starter relay  
• Loose or disconnected starter motor lead wire

• Faulty ignition switch  
• Faulty engine stop switch  
• Faulty clutch lever position switch  
• Faulty gear position switch  
• Faulty turn signal/side-stand relay  
• Faulty starter button  
• Poor contact of connector  
• Open circuit in wire harness

No voltage

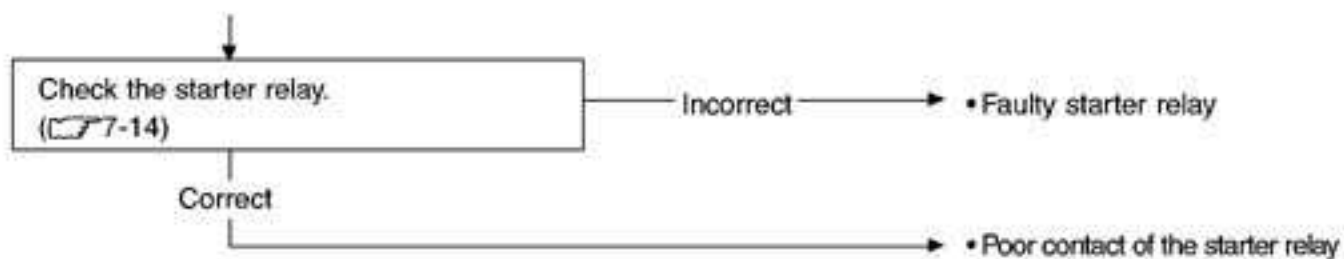

The starter motor runs when the transmission is in neutral, but does not run when the transmission is in any position other than neutral, with the side-stand up.

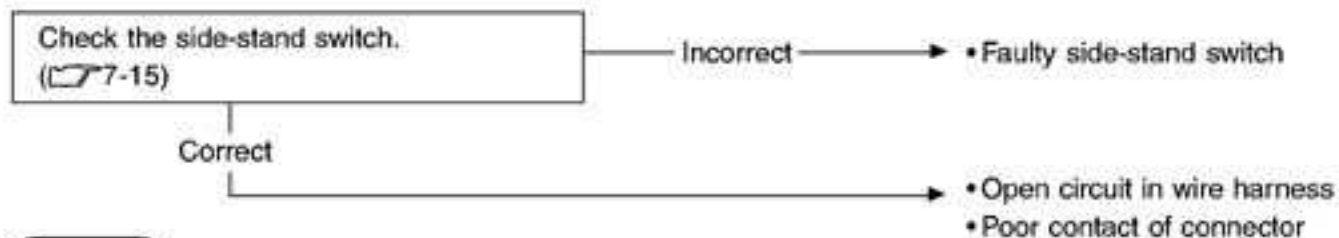

### Others

Engine does not turn though the starter motor runs.

- Faulty starter clutch

## STARTER MOTOR REMOVAL AND DISASSEMBLY

- Remove the oil hose connector ① from the crankcase.
- Disconnect the starter motor lead wire ②.
- Remove the starter motor.

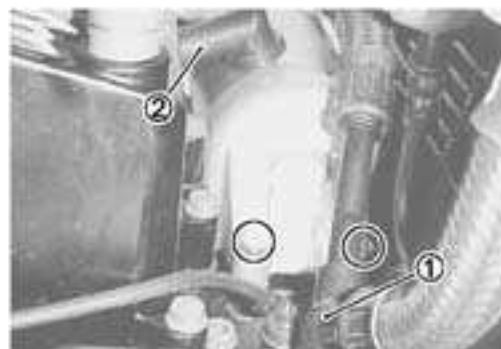

- Disassemble the starter motor as shown in the illustration.

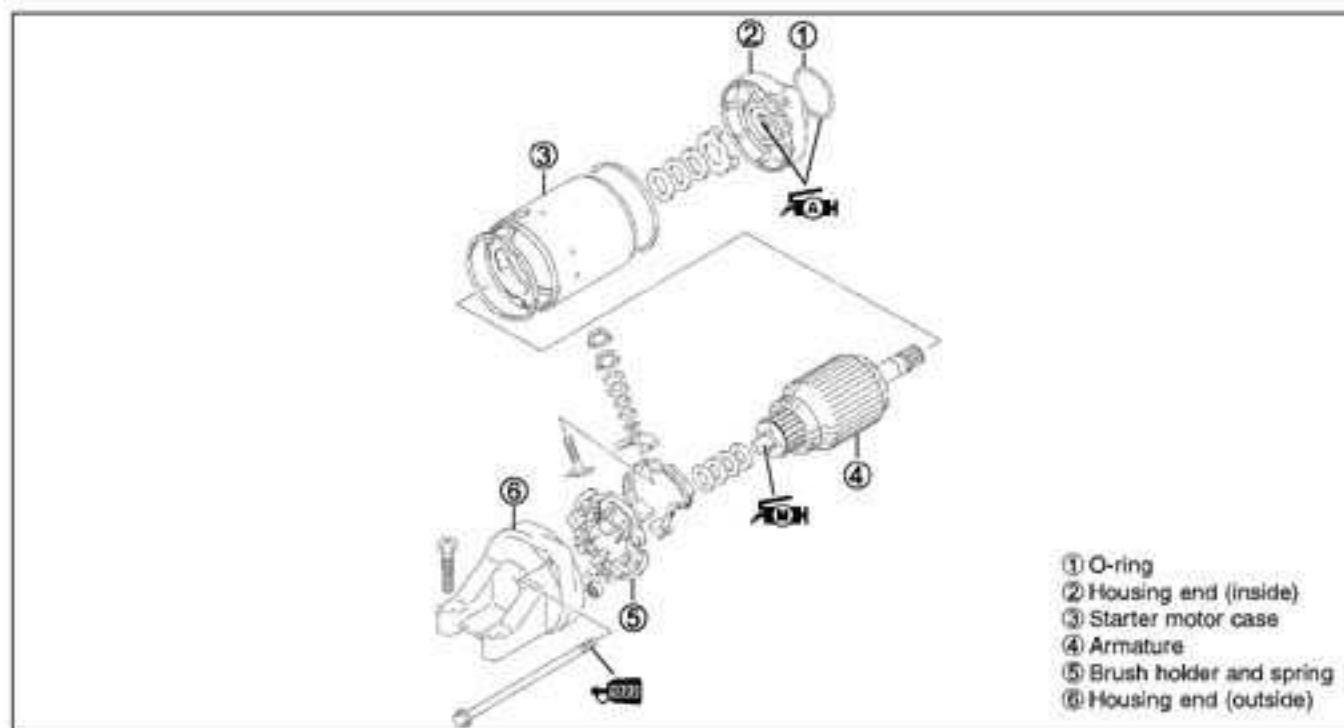

## STARTER MOTOR INSPECTION

### CARBON BRUSH

Inspect the brushes for abnormal wear, cracks, or smoothness in the brush holder.

If any damages are found, replace the brush assembly with a new one.

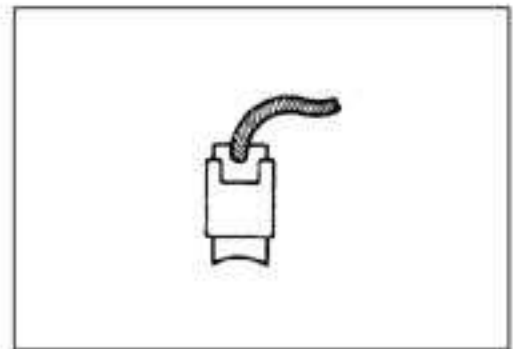

### COMMUTATOR

Inspect the commutator for discoloration, abnormal wear or undercut (A).

If abnormal wear is found, replace the armature with a new one. If the commutator surface is discolored, polish it with #400 sand paper and wipe it using a clean dry cloth.

If there is no undercut, scrape out the insulator (1) with a saw blade.

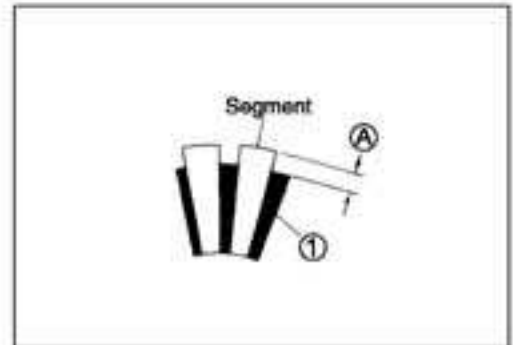

### ARMATURE COIL INSPECTION

Check for continuity between each segment and between each segment and the armature shaft using the multi circuit tester.

If there is no continuity between the segments or there is continuity between the segments and shaft, replace the armature with a new one.

 09900-25008: Multi circuit tester set

 Tester knob indication: Continuity test ()))

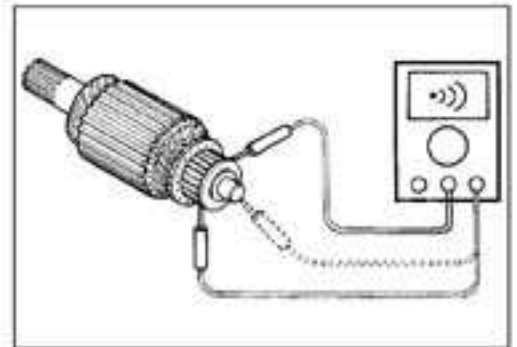

### OIL SEAL INSPECTION

Check the oil seal lip for damage or leakage.

If any damage is found, replace the housing end.



## STARTER MOTOR REASSEMBLY

Reassemble the starter motor in the reverse order of disassembly. Pay attention to the following points:

- Apply grease to the lip of the oil seal.

 99000-25010: SUZUKI SUPER GREASE "A"



- Apply a small quantity of SUZUKI MOLY PASTE to the armature shaft.

 99000-25140: SUZUKI MOLY PASTE

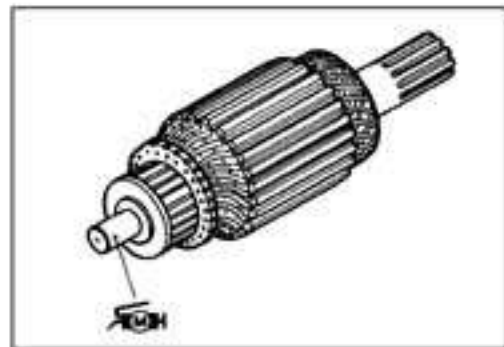

- Apply a small quantity of THREAD LOCK SUPER "1322" to the starter motor housing bolts.

 99000-32110: THREAD LOCK SUPER "1322"

- Apply SUZUKI SUPER GREASE "A" to the O-ring.

 99000-25010: SUZUKI SUPER GREASE "A"

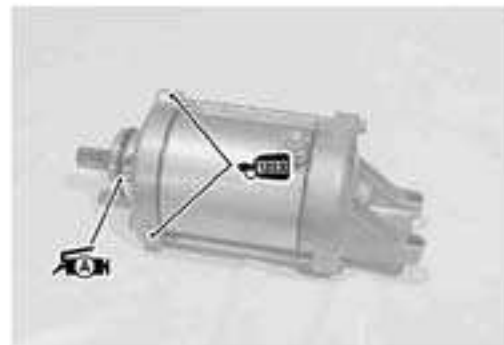

- Tighten the starter motor lead wire mounting nut.

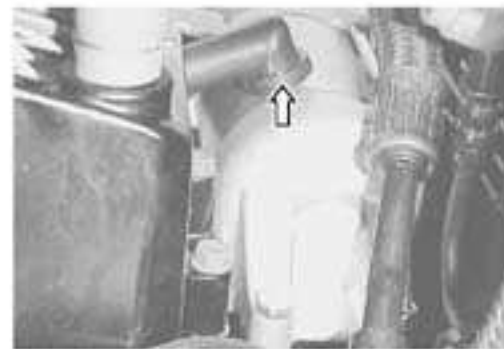

## STARTER RELAY INSPECTION

- Remove the seat. (6-3)
- Remove the left frame cover.
- Disconnect the battery  $\ominus$  lead wire from the battery.
- Remove the starter relay cover.
- Disconnect the starter motor lead wire ①, battery lead wire ② and starter relay coupler ③.
- Remove the starter relay ④.

Apply 12 V to (A) and (B) terminals and check for continuity between the positive and negative terminals using the multi circuit tester. If the starter relay clicks and continuity is found, the relay is ok.

 09900-25008: Multi circuit tester set

 Tester knob indication: Continuity test (•||)

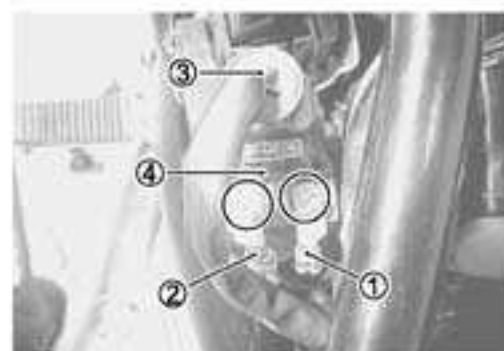

### CAUTION

Do not apply a battery voltage to the starter relay for more than five seconds, since the relay coil may overheat and damaged.

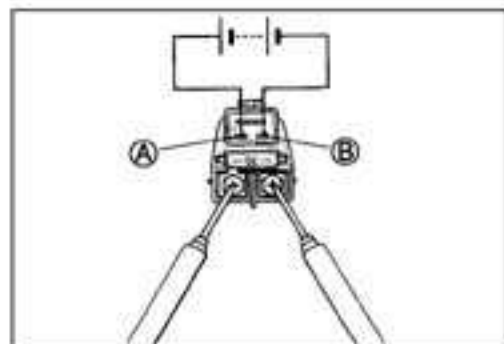



Measure the relay coil resistance between the terminals using the multi circuit tester. If the resistance is not within the specified value, replace the starter relay with a new one.

 09900-25008: Multi circuit tester set

 Tester knob Indication: Resistance ( $\Omega$ )

**DATA** Starter relay resistance: 3 – 5  $\Omega$

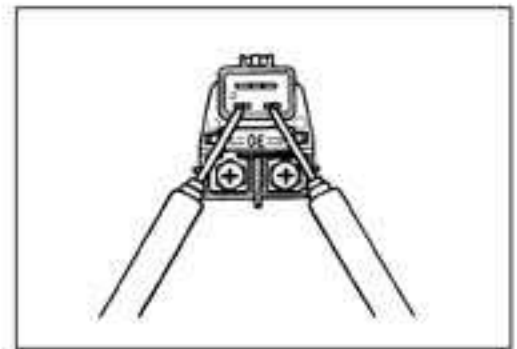

## SIDE STAND/IGNITION INTERLOCK SYSTEM PARTS INSPECTION

Check the interlock system for proper operation. If the interlock system does not operate properly, check each component for damage or abnormalities. If any abnormality is found, replace the component with a new one.

### SIDE-STAND SWITCH

- Remove the left frame cover. ( 6-3)
- Disconnect the side-stand switch coupler and measure the voltage between Green and Black/White lead wires.

 09900-25008: Multi circuit tester set

 Tester knob indication: Diode test ( $\rightarrow\leftarrow$ )

	Green ( $\oplus$ Probe)	Black/White ( $\ominus$ Probe)
ON (Side-stand up)	0.4–0.6 V	
OFF (Side-stand down)	More than 1.4 V (Tester's battery voltage)	

#### NOTE:

If the tester reads under 1.4V when the tester probes are not connected, replace its battery.



**GEAR POSITION SWITCH**

- Remove the left frame cover.
- Disconnect the gear position switch coupler and check the continuity between Blue and Black/White with the transmission in "NEUTRAL".

	Blue	Black/White
ON (Neutral)	○ — ○	○ — ○
OFF (Except neutral)		

**CAUTION**

When disconnecting and connecting the gear position switch coupler, make sure to turn OFF the ignition switch, or electronic parts may get damaged.

- Connect the gear position switch coupler to the wiring harness.
- Turn the ignition switch to "ON" position and side-stand to up-right position.

Measure the voltage between Pink and Black/White lead wires using a multi circuit tester, when shifting the gearshift lever from low to top.

 09900-25008: Multi circuit tester set

 Tester knob indication: Voltage (---)

**DATA** Gear position switch voltage: More than 0.6V  
 (\* Low to top gear position) (Pink – B/W)  
 (\* Except neutral position)

**NOTE:**

- \* When connecting the multi circuit tester, install the copper wire (O.D is below 0.5 mm) to the back side of the lead wire coupler and connect the probes of tester to them.
- \* Use the copper wire, its outer diameter is below 0.5 mm, to prevent the rubber of the water proof coupler from damage.

**TURN SIGNAL/SIDE-STAND RELAY**

The turn signal/side-stand relay is composed of the turn signal relay, and the side-stand relay and diode.

- Remove the left frame cover.
- Remove the turn signal/side-stand relay.

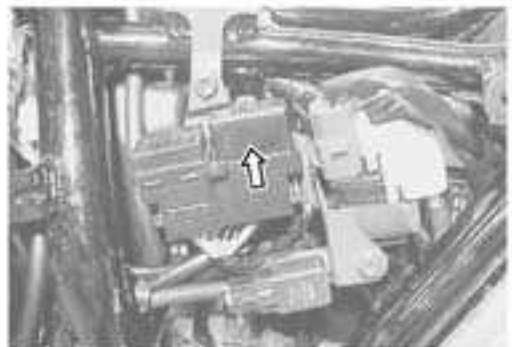

**SIDE-STAND RELAY INSPECTION**

First check the insulation between **D** and **E** terminals with the tester. Then apply 12V to terminals **D** and **C** (+ to **D** and - to **C**) and check the continuity between **D** and **E**. If there is no continuity, replace the turn signal/side-stand relay with a new one.

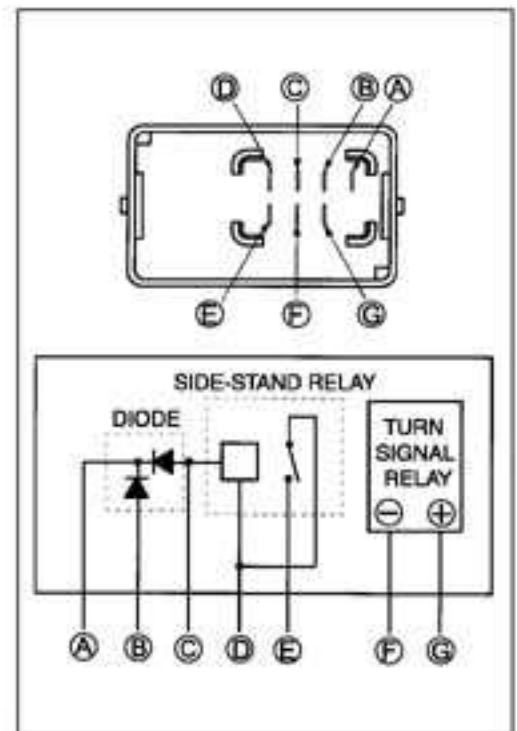
**DIODE INSPECTION**

Measure the voltage between the terminals using the multi circuit tester. Refer to the following table.

Unit: V

⊖ Probe of tester to:	⊕ Probe of tester to:	
	C, B	A
C, B		More than 1.4 V (Tester's battery voltage)
A	0.4-0.6	

 09900-25008: Multi circuit tester set

 Tester knob indication: Diode test (→←)

**NOTE:**

If the multi circuit tester reads under 1.4V when the tester probes are not connected, replace its battery.

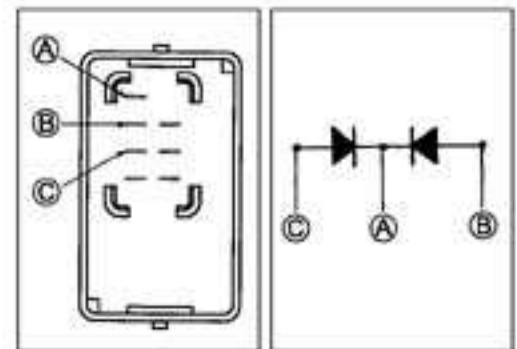

## IGNITION SYSTEM

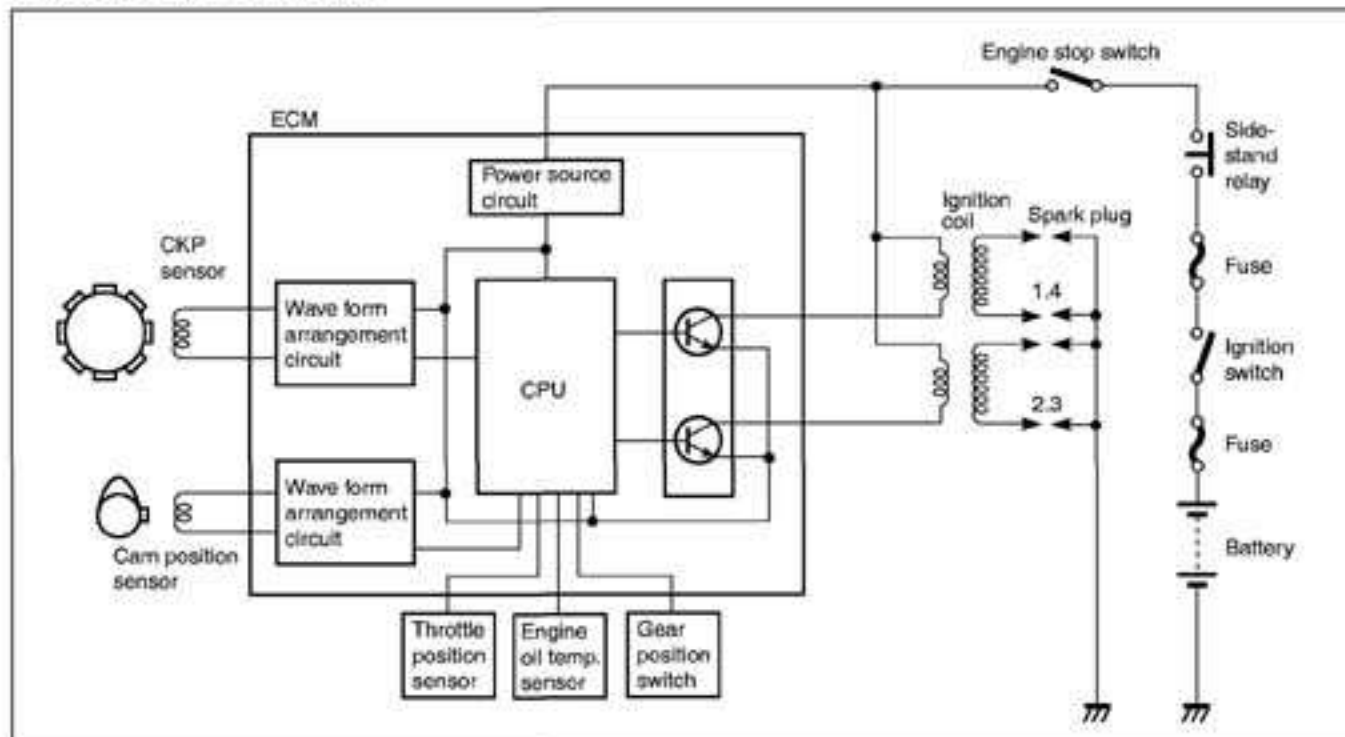
**NOTE:**

The ignition cut-off circuit is incorporated in this ECM to prevent over-running of engine. If engine rpm reaches 9 200 r/min., this circuit cuts off the ignition primary current for all spark plugs.

**CAUTION**

Under no load, the engine can run over 9 200 r/min, even if the ignition cut-off circuit is effective, and it may cause engine damage. Do not run the engine without load over 9 200 r/min at anytime.

## TROUBLESHOOTING

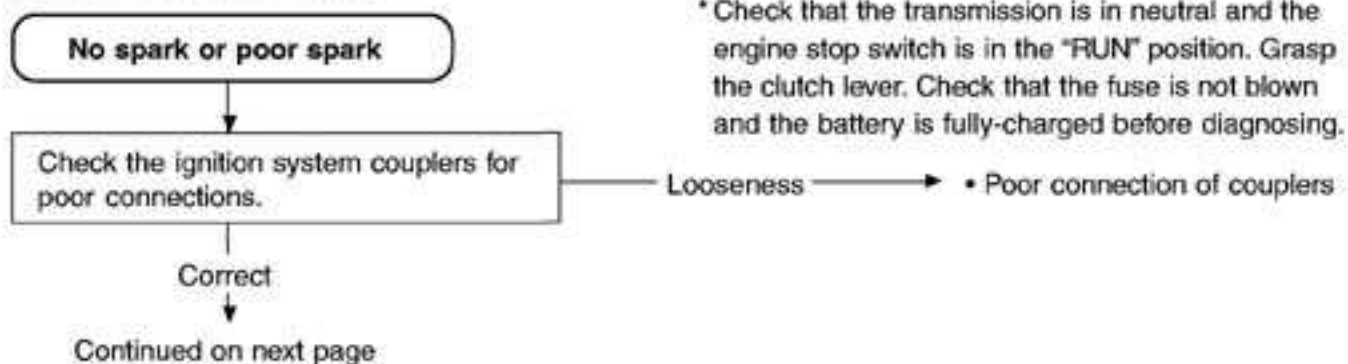

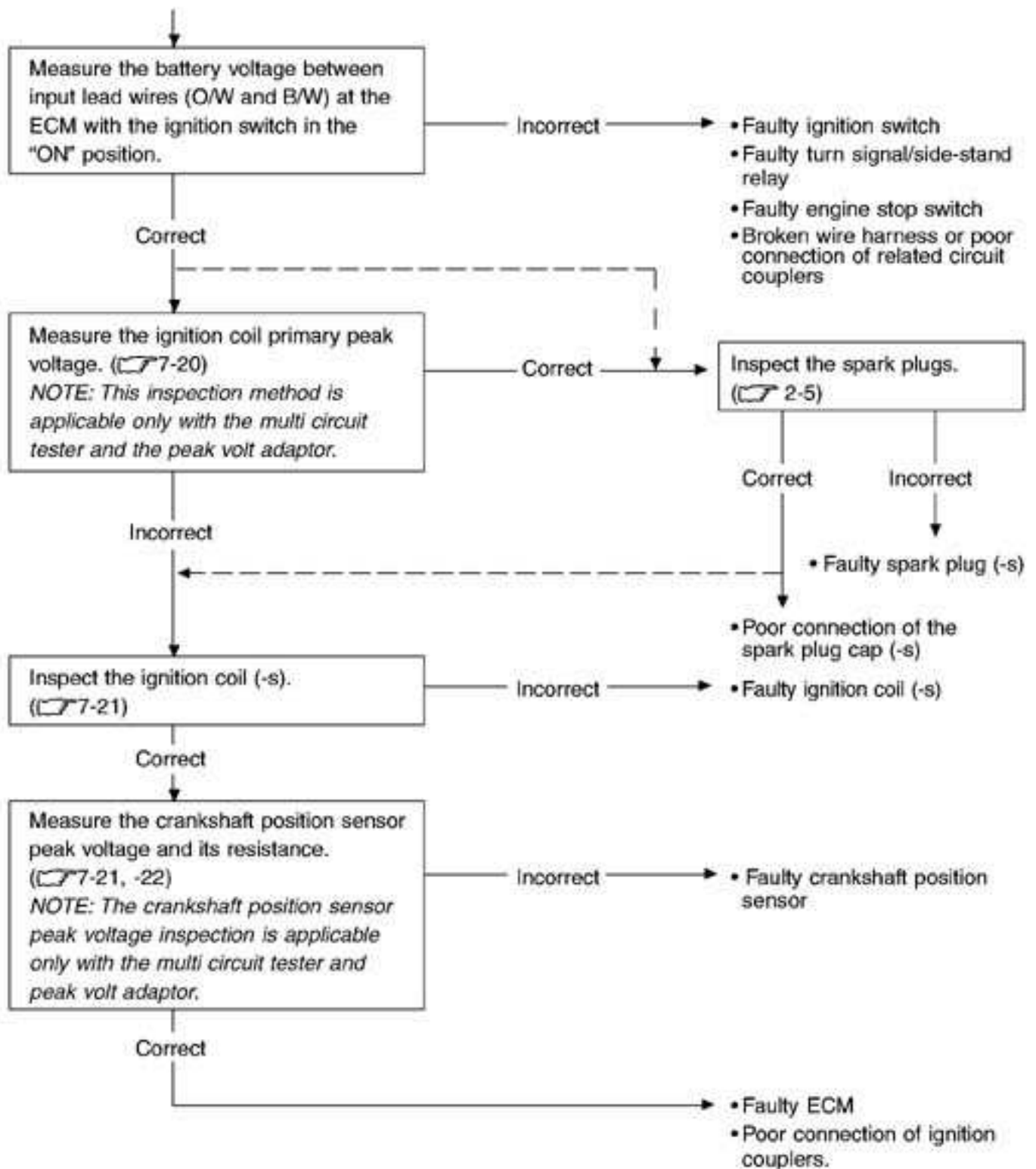

## INSPECTION

### IGNITION COIL PRIMARY PEAK VOLTAGE

- Remove the fuel tank. (☞ 4-48)
- Disconnect the four spark plug caps.
- Connect new four spark plugs to each spark plug cap and ground them to the ignition coil brackets.

#### NOTE:

Make sure that all couplers and spark plugs are connected properly and the battery used is in fully-charged condition.

Measure the No. 1 & 4 and No. 2 & 3 ignition coils primary peak voltage in the following procedure.

- Connect the multi circuit tester with peak voltage adaptor as follows.

- No. 1 & 4 ignition coil: ⊕ Probe: White/Blue  
 ⊖ Probe: Orange/White
- No. 2 & 3 ignition coil: ⊕ Probe: Black  
 ⊖ Probe: Orange/White

#### NOTE:

Do not disconnect the ignition coil primary wire coupler.

 09900-25008: Multi circuit tester set

### CAUTION

**Before using the multi circuit tester and peak volt adaptor, be sure to refer to the appropriate instruction manual.**

- Shift the transmission into the neutral and then turn the ignition switch to the "ON" position.
- Pull the clutch lever.
- Press the starter button and allow the engine to crank for a few seconds, and then measure the ignition coil primary peak voltage.
- Repeat the above procedure a few times and measure the highest ignition coil primary peak voltage.

 Tester knob indication: Voltage (---)

**DATA** Ignition coil primary peak voltage: More than 150 V

### WARNING

**While testing, do not touch the tester probes and spark plugs to prevent receiving an electric shock .**

If the peak voltage is lower than the specified values, inspect the ignition coil. (☞ 7-21)

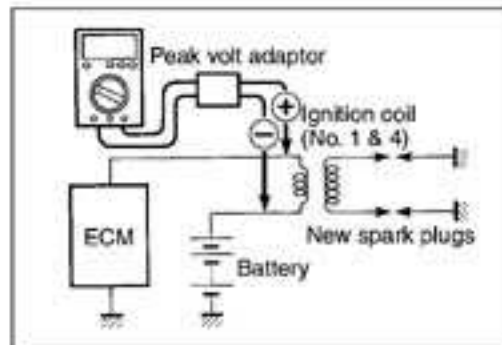

**IGNITION COIL RESISTANCE**

- Remove the fuel tank. (☞ 4-48)
- Disconnect the spark plug caps and coupler, and remove the ignition coil.

Measure the ignition coil resistance in both the primary and secondary windings. If the resistance is not within the standard range, replace the ignition coil with a new one.

**TOOL** 09900-25008: Multi circuit tester set

**TESTER** Tester knob indication: Resistance ( $\Omega$ )

**DATA** Ignition coil resistance

Primary : 2 – 4  $\Omega$  (+ tap – - tap)

Secondary : 25 – 40 k $\Omega$  (Plug cap – Plug cap)

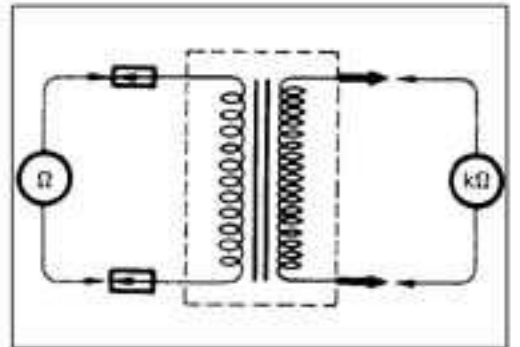
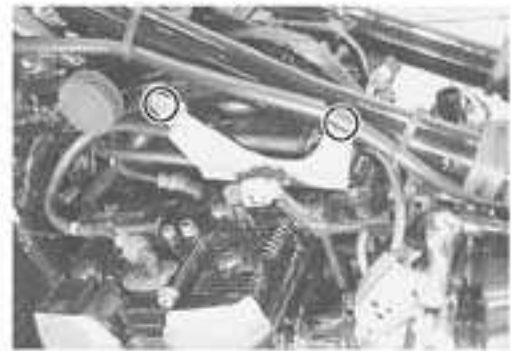
**CKP SENSOR PEAK VOLTAGE**

- Remove the seat. (☞ 6-3)
- Remove the tray.
- Disconnect the ECM coupler.

**NOTE:**

Make sure that all of the couplers are connected properly and the battery used is in fully-charged condition.

Measure the CKP sensor peak voltage in the following procedures.

- Connect the multi circuit tester with peak volt adaptor as follows.

⊕ Probe: White lead wire

⊖ Probe: Black/Brown lead wire

**TOOL** 09900-25008: Multi circuit tester set

**CAUTION**

Before using the multi circuit tester and peak volt adaptor, be sure to refer to the appropriate instruction manual.

- Shift the transmission into the neutral, and then turn the ignition switch to the "ON" position.
- Pull the clutch lever.
- Press the starter button and allow the engine to crank for a few seconds, and then measure the CKP sensor peak voltage.
- Repeat the above procedure a few times and measure the highest peak voltage.

**TESTER** Tester knob indication: Voltage (---)

**DATA** CKP sensor peak voltage: More than 2.7 V

If the peak voltage is lower than the specified values, check the peak voltage at the CKP sensor lead wire coupler.

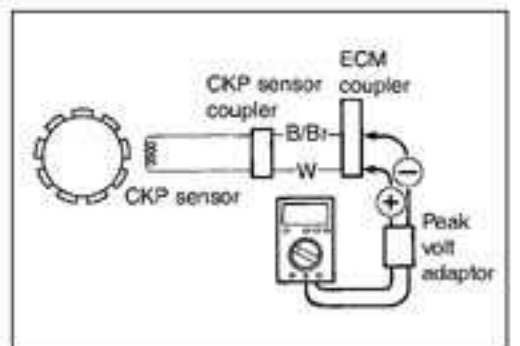
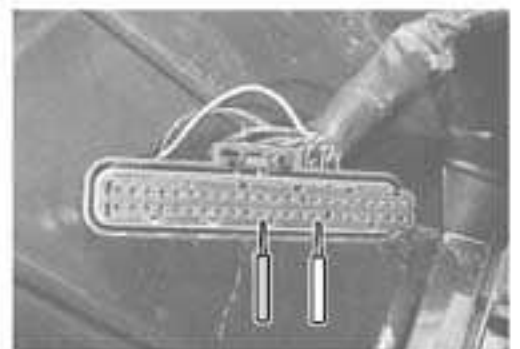
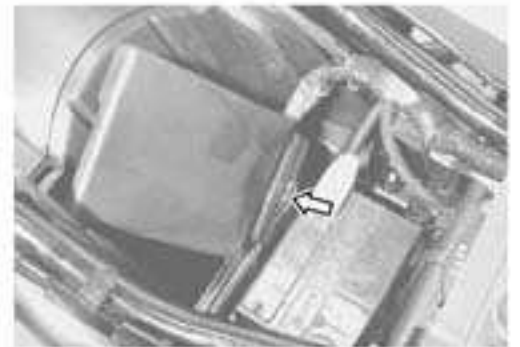



- Remove fuel tank. (☞ 4-48)
- Disconnect the CKP sensor lead wire coupler and connect the multi circuit tester with the peak volt adaptor.
- ⊕ Probe: Yellow lead wire
- ⊖ Probe: Blue lead wire
- Measure the CKP sensor peak voltage at the CKP sensor lead wire coupler in the same manner as on the ECM coupler.

 **Tester knob indication: Voltage (V)**

**DATA CKP sensor peak voltage: More than 2.7 V**

If the peak voltage on the CKP sensor lead wire coupler is ok but on the ECM coupler is out of specification, the wire harness must be replaced. If both peak voltages are out of specification, the CKP sensor must be replaced and re-checked.

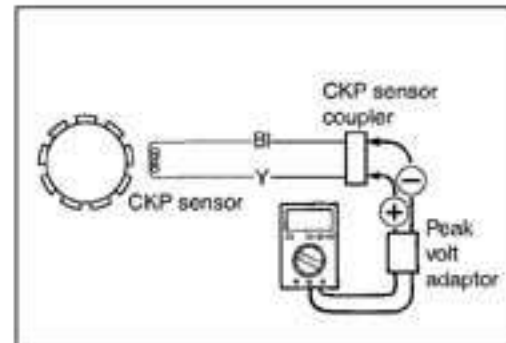

### CKP SENSOR RESISTANCE

Measure the resistance between the lead wires and ground. If the resistance is not specified value, the CKP sensor must be replaced.

 **09900-25008: Multi circuit tester set**

 **Tester knob indication: Resistance (Ω)**

**DATA CKP sensor resistance : 130 – 210 Ω (Yellow – Blue)  
: ∞ Ω (Green – Ground)**

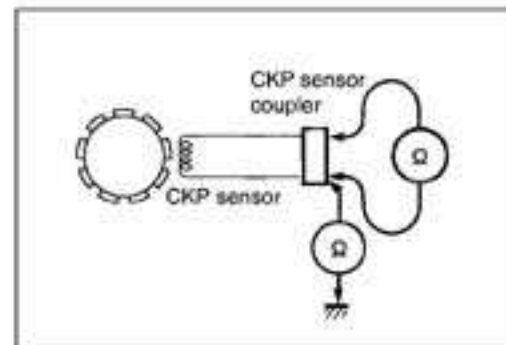

## COMBINATION METER

### REMOVAL AND DISASSEMBLY

- Remove the headlight. (☞6-24)
- Remove the headlight housing.
- Remove the combination meter.

#### CAUTION

When disconnecting and connecting the combination meter coupler, make sure to turn OFF the ignition switch, or electronic parts may get damaged.

- Disassemble the combination meter as follows.

#### CAUTION

Do not attempt to disassemble the combination meter unit ②.

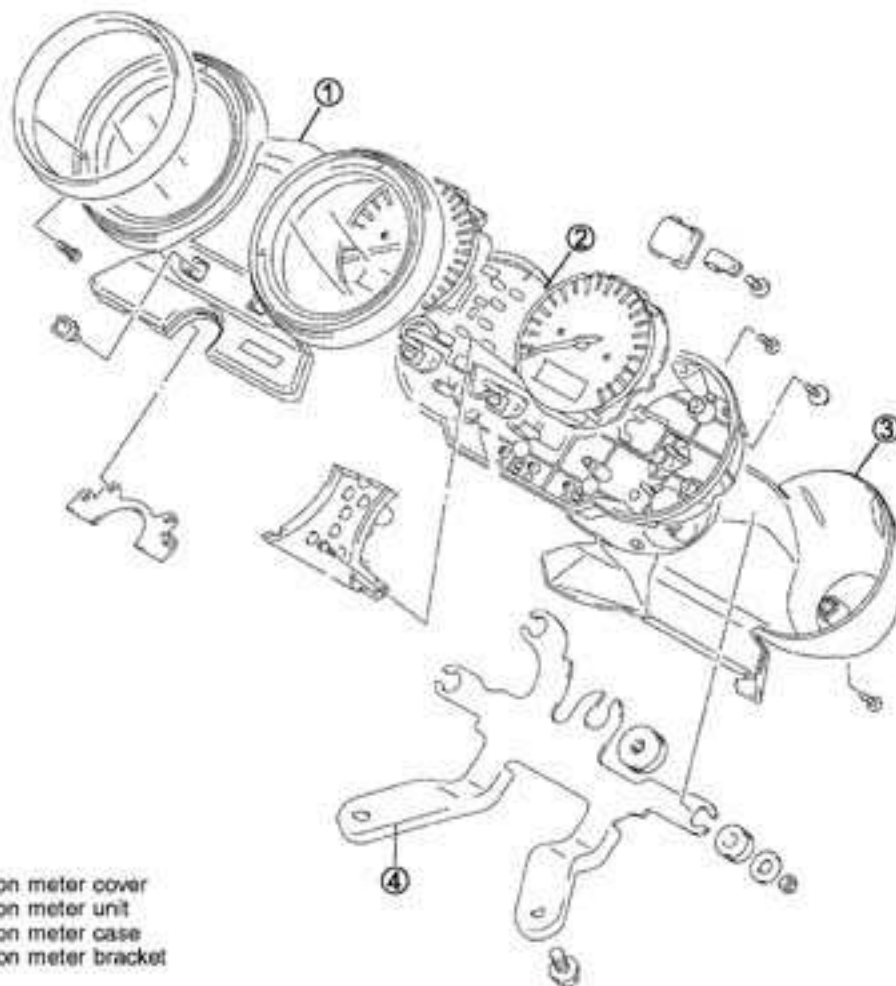

## INSPECTION

### LED (LIGHT EMITTING DIODE)

Check that the LED lights immediately after turning the ignition switch on.

If the LED fails in operation, replace the combination meter unit with a new one after checking its wire harness/coupler.

### STEPPING MOTOR

Check that the pointer calibrates itself immediately after turning the ignition switch on and stops at starting point.

If abnormal condition is found, replace the combination meter unit with a new one after checking its wire harness/coupler.

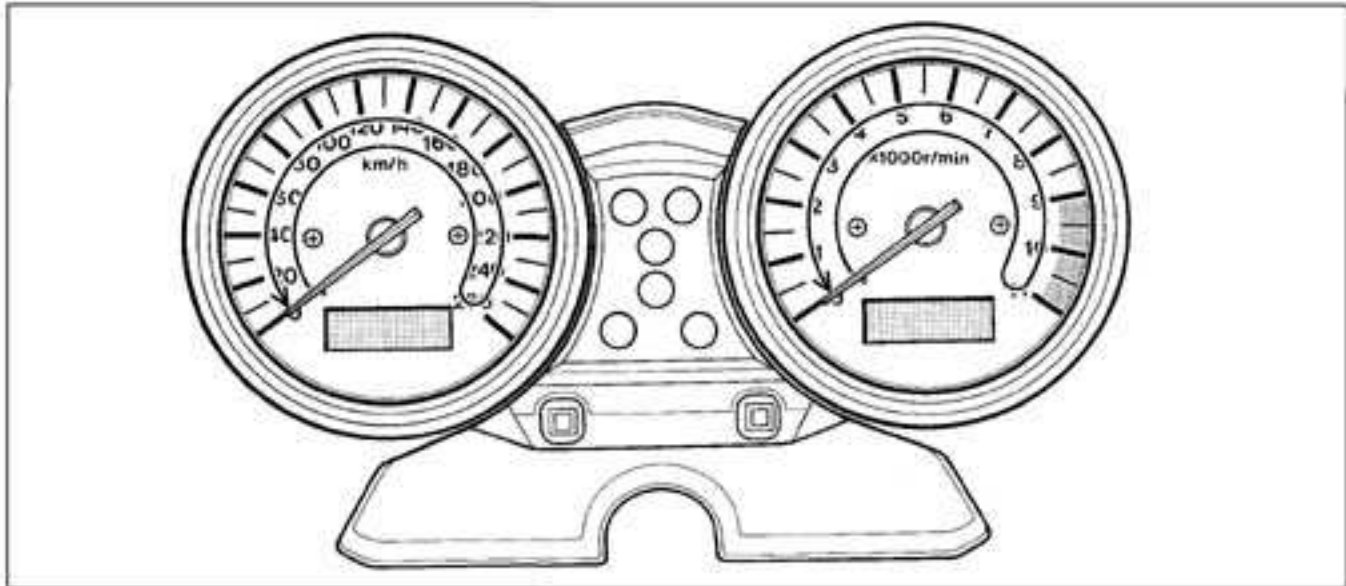

#### NOTE:

The pointer may not return to the proper position even turning the ignition switch on under low temperature condition. In that case, you can reset the pointer to the proper position by following the instruction below:

- 1) With the reset switch (A) pressed, turn the ignition switch on.
  - 2) Release the function switch (A), 3 to 5 seconds after turning the ignition switch on.
  - 3) Press the function switch (A) twice (within 1 second). → Reset
- \* Complete the operation within 10 seconds after the ignition switch has been turned on.

Time	Ignition switch	Adjuster switch (A)
	OFF	PUSH
0	ON	↓
•		
•		
3 sec		↓
•		
5 sec		Release
•		
•		Push
•		Push → Reset
10 sec		

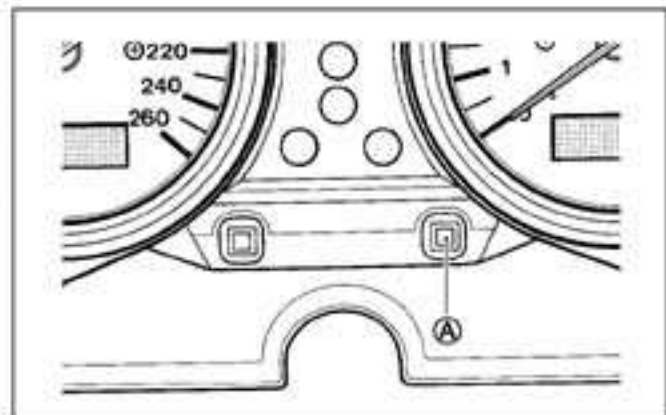

Pointer will return to the starting point right after the completion of the operation. In the case of the pointer not returning to the proper position after doing above, replace the combination meter unit.

**FUEL LEVEL METER**

- Remove the fuel tank. (☞ 4-48)
- Connect each resistor between the Yellow/Black and Black/White lead wires at the wire harness.
- Turn the ignition switch "ON" position and wait for approx. 13 seconds.

Check the display of fuel meter as shown below. If any abnormality is found, replace the combination meter with a new one.

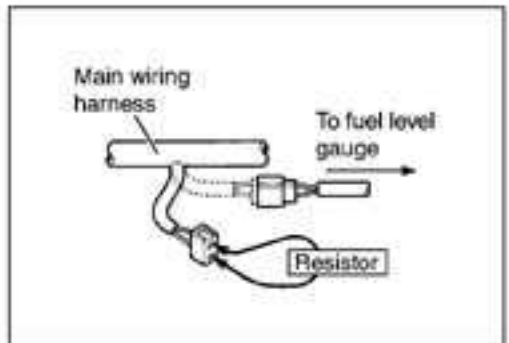

Resistance	More than 90 Ω	76 – 82 Ω	62 – 70 Ω	47 – 56 Ω	31 – 42 Ω	Less than 27 Ω
Fuel level meter						

**OIL PRESSURE INDICATOR****NOTE:**

Before inspecting the oil pressure switch, check if the engine oil level is enough. (☞ 2-13)

- Remove the CKP sensor cover.
- Disconnect the oil pressure switch lead wire from the oil pressure switch.
- Turn the ignition switch "ON" position.

Check if the oil pressure indicator will light, when grounding the lead wire.

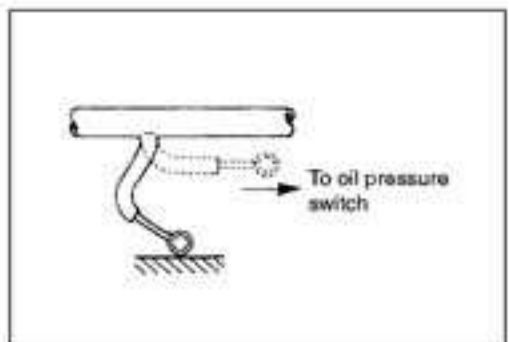
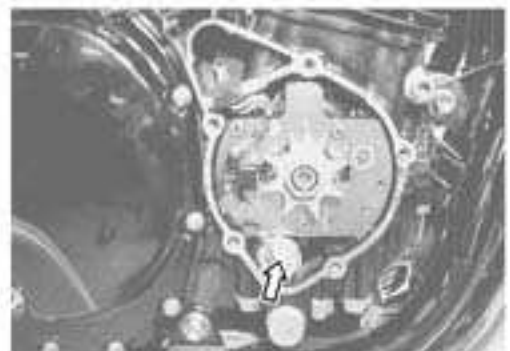

**FUEL LEVEL GAUGE INSPECTION**

- Remove the fuel tank. (☞ 4-48)
- Disconnect the hose ①.
- Remove the fuel level gauge ②.

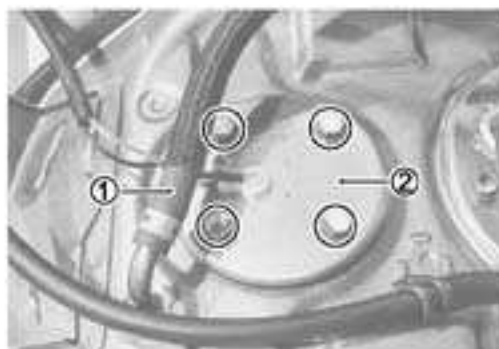

Measure the resistance at each fuel level gauge float position. If the resistance is incorrect, replace the fuel level gauge with a new one.

Float position	Resistance
Ⓐ "F" (Full)	4 – 10 Ω
Ⓑ "E" (Empty)	90 – 100 Ω

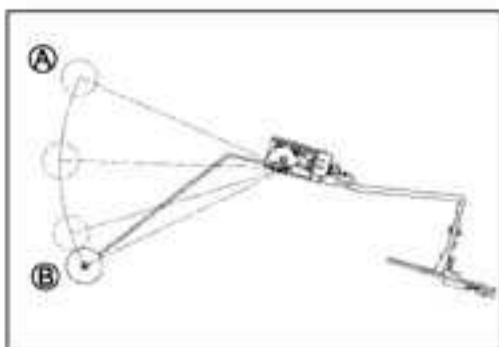

Remount the fuel level gauge in the reverse order of removal. Pay attention to the following points.

- Apply grease to the O-ring.

 99000-25010: SUZUKI SUPER GREASE "A"

**CAUTION**

**Use a new O-ring to prevent fuel leakage.**

- Lightly tighten the fuel level gauge mounting bolts in the ascending order of numbers, and then tighten them to the specified torque in the above manner.

 Fuel level gauge bolt: 10 N·m (1.0 kgf·m, 7.0 lb-ft)

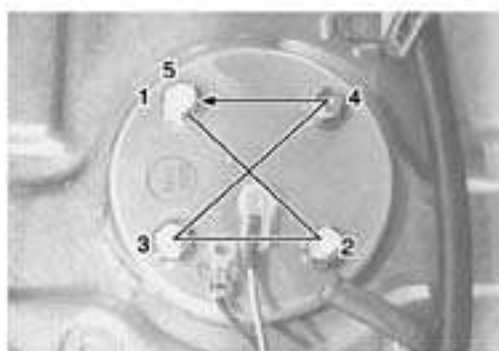

## SPEEDOMETER

If the speedometer, odometer or trip meter does not function properly, inspect the speedometer sensor and connection of couplers. If the speedometer sensor and connection are all right, replace the meter with a new one.

### SPEEDOMETER SENSOR

- Remove the left frame cover. (☞ 6-3)
- Remove the engine sprocket cover.
- Disconnect speedometer sensor coupler.
- Remove the speedometer sensor ① by removing its mounting bolt.
- Connect 12V battery, 10 k $\Omega$  resistor and the multi circuit tester as shown right illustration.

**B/R:** Black with Red tracer

**B/W:** Black with White tracer

**B:** Black

 09900-25008: Multi circuit tester set

 Tester knob indication: Voltage (---)

- Under above condition, if a suitable screwdriver touching the pick-up surface of the speedometer sensor is moved, the tester reading voltage changes (0V→12V or 12V→0V). If the tester reading voltage does not change, replace the speedometer sensor with a new one.

#### NOTE:

The highest tester reading voltage (12V) while testing is same as battery voltage.

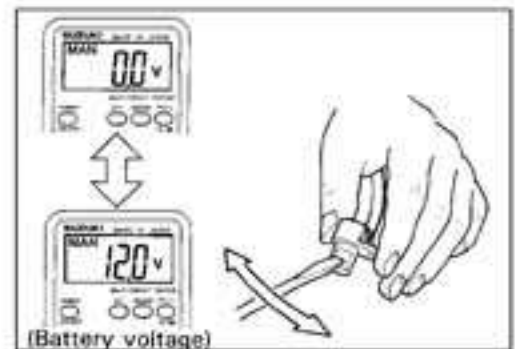
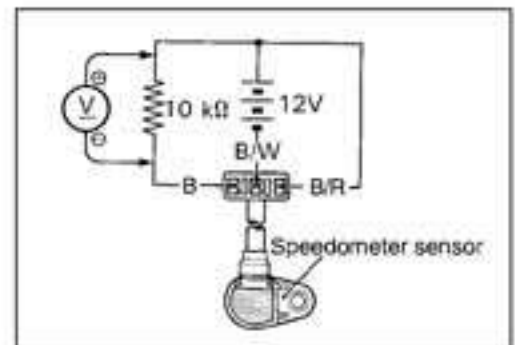
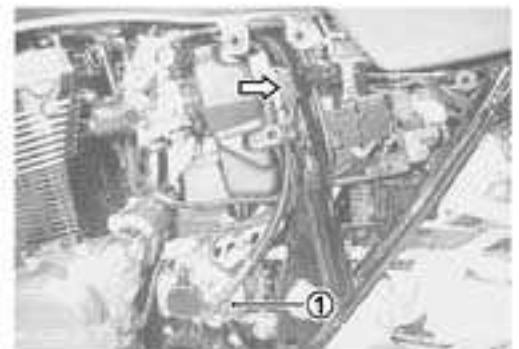

## LAMPS

### HEADLIGHT, BRAKE LIGHT/TAILLIGHT AND TURN SIGNAL LIGHT

#### HEADLIGHT

12 V 60/55 W ..... E-24

12 V 60/55 W + 5 W .. E-02, 19

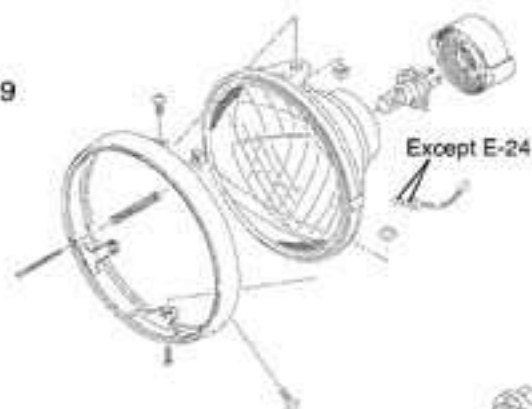

#### BRAKE LIGHT/TAILLIGHT

12 V 21/5 W

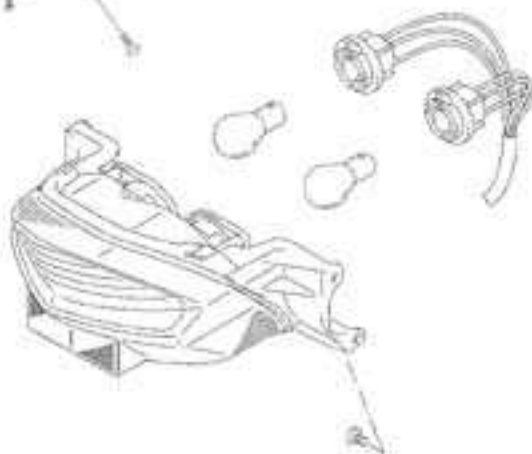

#### TURN SIGNAL LIGHT

12 V 21 W

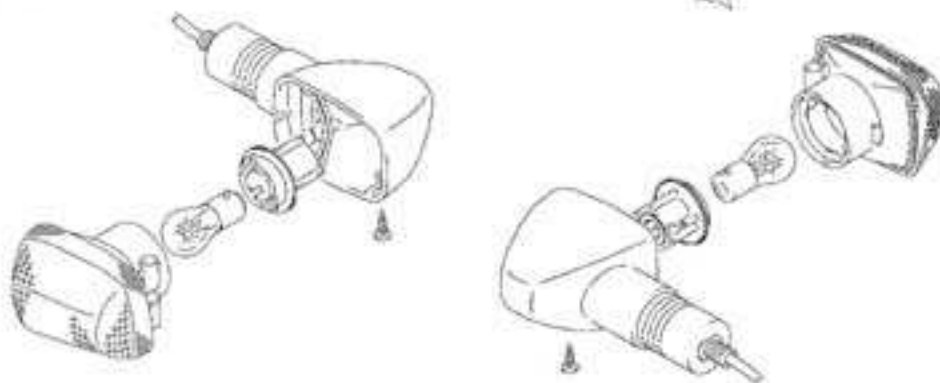

#### CAUTION

If you touch the bulb with your bare hands, clean it with a cloth moistened with alcohol or soapy water to prevent early failure.

#### HEADLIGHT BEAM ADJUSTMENT

- Adjust the headlight beam, both vertical and horizontal.
  - (A): Vertical adjuster
  - (B): Horizontal adjuster





## RELAYS

### TURN SIGNAL/SIDE-STAND RELAY

The turn signal/side-stand relay is composed of the turn signal relay, side-stand relay and diode.

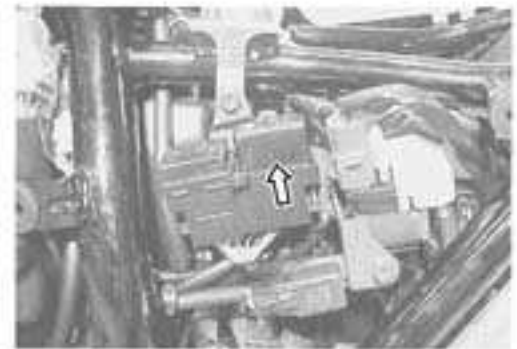

#### INSPECTION

Before removing the turn signal/side-stand relay, check the operation of the turn signal light.

If the turn signal light does not illuminate, inspect the bulb, turn signal switch and circuit connection.

If the bulb, turn signal switch and circuit connection are OK, the turn signal relay may be faulty; therefore, replace the turn signal/side-stand relay with a new one.

#### NOTE:

- \* Make sure that the battery is fully charged.
- \* Refer to the page 7-17 for the side-stand relay and diode inspection.

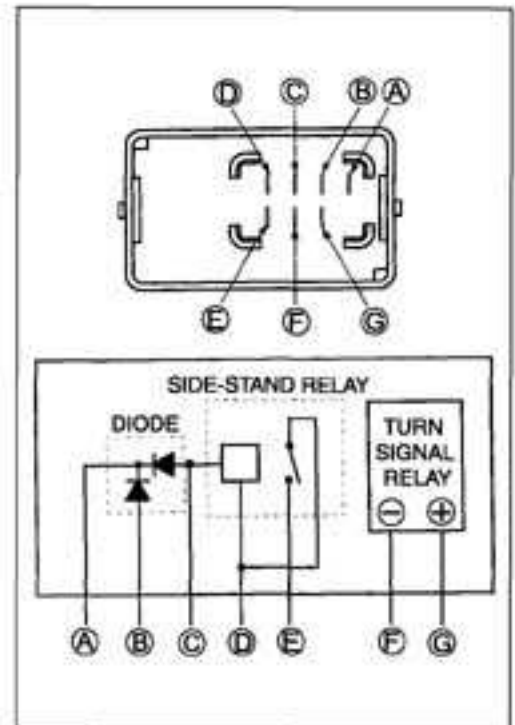

### STARTER RELAY

7-14

### FUEL PUMP RELAY

4-47

## SWITCHES

### IGNITION SWITCH REMOVAL

- Remove the headlight housing. (6-24)
- Remove the ignition switch mounting bolts using the special tools.

09930-11920: Torx bit JT40H  
09930-11940: Bit holder

#### CAUTION

When reusing the ignition switch bolt, clean thread and apply the **THREAD LOCK SUPER "1322"**

99000-32110: **THREAD LOCK SUPER "1322"**



Inspect each switch for continuity with a tester. If any abnormality is found, replace the respective switch assemblies with new ones.

**IGNITION SWITCH**

(For E-24)

Color Position	R	O	O/Y	B/W
ON				
OFF				
LOCK				

(For Others)

Color Position	R	O	O/Y	B/W	Gr	Br
ON						
OFF						
LOCK						
P						

**LIGHTING SWITCH**

(Except for E-24)

Color Position	O/Bl	Gr	O/R	Y/W
OFF (•)				
S (•)				
ON (•)				

**DIMMER SWITCH**

Color Position	W	Y	Y/W
HI (H)			
LO (L)			

**TURN SIGNAL SWITCH**

Color Position	Lg	Lbl	B
L			
PUSH			
R			

**PASSING LIGHT SWITCH**

(Except for E-24)

Color Position	O/R	Y
•		
PUSH		

**ENGINE STOP SWITCH**

Color Position	O/B	O/W
OFF (X)		
RUN (O)		

**STARTER BUTTON**

Color Position	O/W	Y/G
•		
PUSH		

**HORN BUTTON**

Color Position	B/Bl	B/W
•		
PUSH		

**FRONT BRAKE SWITCH**

Color Position	B/R	B
OFF		
ON		

**REAR BRAKE SWITCH**

Color Position	O/G	W/B
OFF		
ON		

**CLUTCH LEVER POSITION SWITCH**

Color Position	B/Y	B/Y
OFF		
ON		

**OIL PRESSURE SWITCH**

Color Position	G/Y	Ground
ON (engine is stopped)		
OFF (engine is running)		

**NOTE:**

Before inspecting the oil pressure switch, check if the engine oil level is enough. (2-13)

**WIRE COLOR**

B : Black      Lbl : Light blue      R : Red  
 Br : Brown      Lg : Light green      Y : Yellow  
 Gr : Gray      O : Orange      W : White

B/Bl : Black with Blue tracer  
 B/W : Black with White tracer  
 B/Y : Black with Yellow tracer  
 B/R : Black with Red tracer  
 G/Y : Green with Yellow tracer  
 O/B : Orange with Black tracer  
 O/Bl : Orange with Blue tracer  
 O/G : Orange with Green tracer  
 O/R : Orange with Red tracer  
 O/W : Orange with White tracer  
 O/Y : Orange with Yellow tracer  
 W/B : White with Black tracer  
 Y/G : Yellow with Green tracer  
 Y/W : Yellow with White tracer

## BATTERY SPECIFICATIONS

Type designation	FTX14-BS
Capacity	12V, 43.2 kC (12 Ah)/10HR

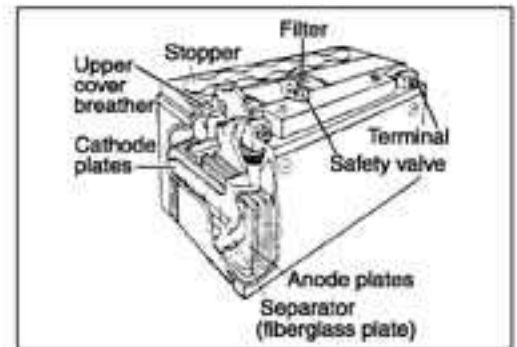

## INITIAL CHARGING

### Filling electrolyte

- Remove the aluminum tape ① sealing the battery electrolyte filler holes.

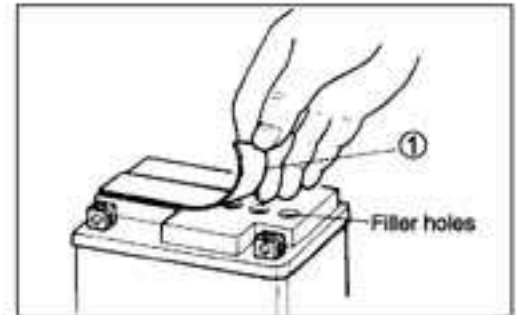

- Remove the caps ②.

### NOTE:

- After filling the electrolyte completely, use the removed cap ② as the sealed caps of battery-filler holes.
- Do not remove or pierce the sealed areas ③ of the electrolyte container.

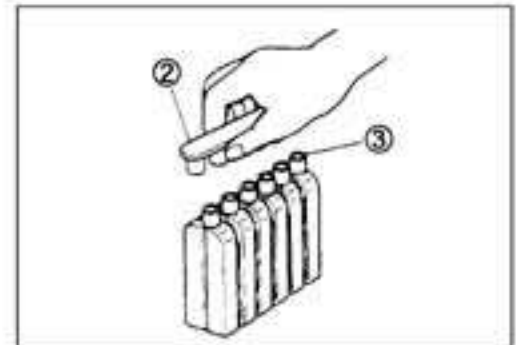

- Insert the nozzles of the electrolyte container into the battery's electrolyte filler holes, holding the container firmly so that it does not fall. Take precaution not to allow any of the fluid to spill.

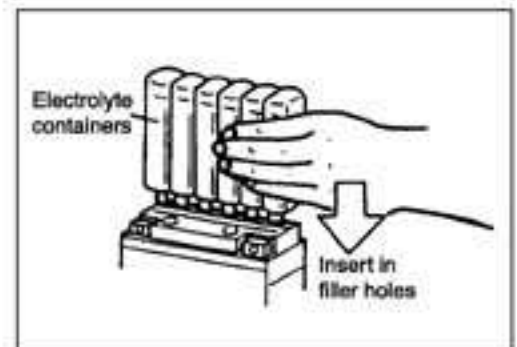

- Make sure air bubbles are coming up each electrolyte container, and leave in this position for about more than 20 minutes.

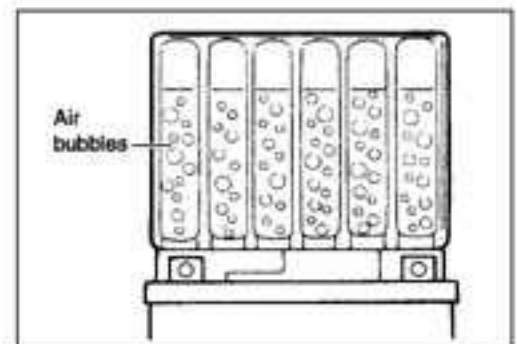

**NOTE:**

If no air bubbles are coming up from a filler port, tap the bottom of the electrolyte container two or three times.

Never remove the container from the battery.

- After confirming that the electrolyte has entered the battery completely, remove the electrolyte containers from the battery. Wait for about 20 minutes.
- Insert the caps into the filler holes, pressing in firmly so that the top of the caps do not protrude above the upper surface of the battery's top cover.

**CAUTION**

- Never use anything except the specified battery.
- Once install the caps to the battery; do not remove the caps.
- Do not tap the caps with a hammer when installing them.

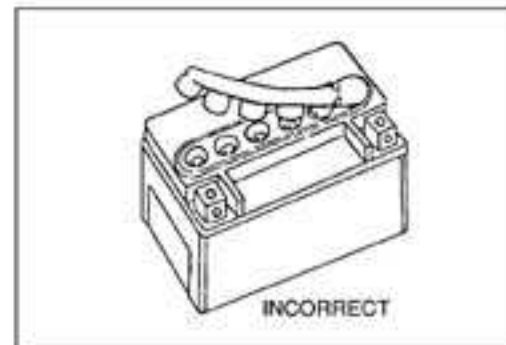
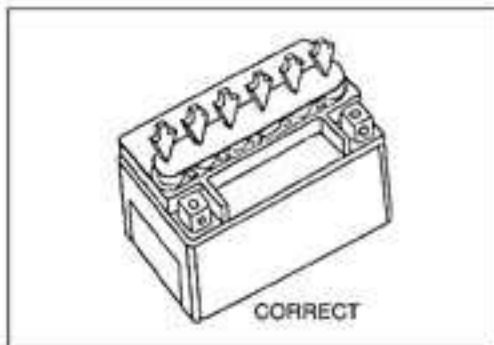
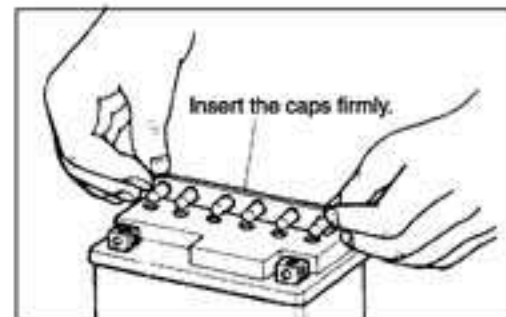
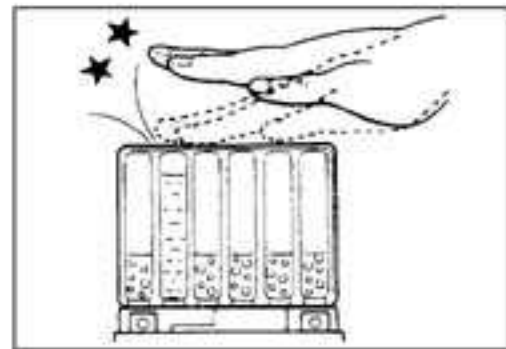

- Using multi circuit tester, measure the battery voltage. The tester should indicate more than 12.5 – 12.6V (DC) as shown in the Fig. If the battery voltage is lower than the specification, charge the battery with a battery charger. (Refer to the recharging operation)

**CAUTION**

Do not remove the caps on the battery top while charging.

**NOTE:**

Initial charging for a new battery is recommended if two years have elapsed since the date of manufacture.

**SERVICING**

Visually inspect the surface of the battery container. If any signs of cracking or electrolyte leakage from the sides of the battery have occurred, replace the battery with a new one. If the battery terminals are found to be coated with rust or an acidic white powdery substance, then this can be cleaned away with sandpaper.

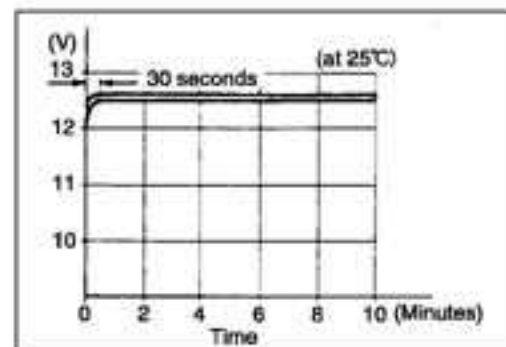

## RECHARGING OPERATION

- Using the multi circuit tester, check the battery voltage. If the voltage reading is less than the 12.0V (DC), recharge the battery with a battery charger.

### CAUTION

- When recharging the battery, remove the battery from the motorcycle.
- Do not remove the caps on the battery top while recharging.

Recharging time: 1.4 A for 5 to 10 hours or 6 A for one hour

### CAUTION

Be careful not to permit the charging current to exceed 6A at any time.

- After recharging, wait for more than 30 minutes and check the battery voltage with a multi circuit tester.
- If the battery voltage is less than the 12.5V, recharge the battery again.
- If battery voltage is still less than 12.5V, after recharging, replace the battery with a new one.
- When the motorcycle is not used for a long period, check the battery every 1 month to prevent the battery discharge.

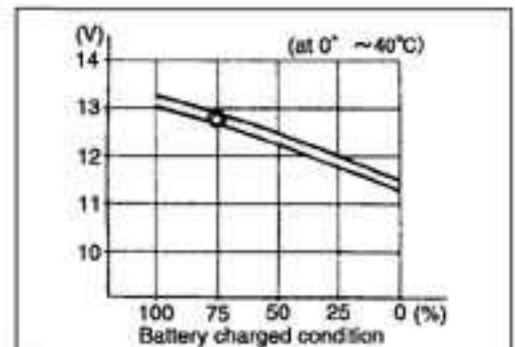
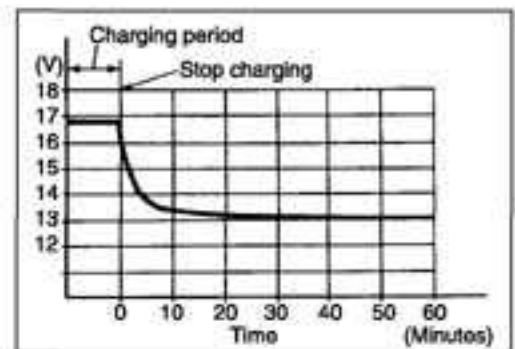

**SERVICING INFORMATION****CONTENTS**

<b>TROUBLESHOOTING .....</b>	<b>8- 2</b>
<b>FI SYSTEM MALFUNCTION CODE AND DEFECTIVE CONDITION .....</b>	<b>8- 2</b>
<b>ENGINE .....</b>	<b>8- 4</b>
<b>COOLING SYSTEM .....</b>	<b>8- 9</b>
<b>CHASSIS.....</b>	<b>8-10</b>
<b>BRAKES .....</b>	<b>8-11</b>
<b>ELECTRICAL .....</b>	<b>8-12</b>
<b>BATTERY .....</b>	<b>8-13</b>
<b>WIRING DIAGRAM .....</b>	<b>8-14</b>
<b>FI SYSTEM WIRING DIAGRAM.....</b>	<b>8-15</b>
<b>WIRE HARNESS, CABLE AND HOSE ROUTING.....</b>	<b>8-16</b>
<b>WIRE HARNESS ROUTING.....</b>	<b>8-16</b>
<b>HIGH-TENSION CORD ROUTING.....</b>	<b>8-17</b>
<b>ENGINE ELECTRICAL PARTS SET-UP .....</b>	<b>8-18</b>
<b>CLUTCH HOSE ROUTING.....</b>	<b>8-19</b>
<b>THROTTLE CABLE ROUTING .....</b>	<b>8-20</b>
<b>FUEL PUMP/FUEL LEVEL GAUGE SET-UP .....</b>	<b>8-21</b>
<b>FRONT BRAKE HOSE ROUTING .....</b>	<b>8-22</b>
<b>REAR BRAKE HOSE ROUTING .....</b>	<b>8-23</b>
<b>SIDE-STAND SET-UP .....</b>	<b>8-24</b>
<b>CENTER STAND SET-UP.....</b>	<b>8-24</b>
<b>SEAT LOCK CABLE ROUTING AND LUGGAGE HOOK SET-UP.....</b>	<b>8-25</b>
<b>BRAKE PEDAL SET-UP.....</b>	<b>8-25</b>
<b>FUEL HOSE ROUTING .....</b>	<b>8-26</b>
<b>FUEL TANK SET-UP .....</b>	<b>8-27</b>
<b>THROTTLE BODY SET-UP .....</b>	<b>8-28</b>
<b>PAIR (AIR SUPPLY) SYSTEM HOSE ROUTING.....</b>	<b>8-29</b>
<b>SPECIAL TOOLS .....</b>	<b>8-30</b>
<b>TIGHTENING TORQUE.....</b>	<b>8-33</b>
<b>SERVICE DATA .....</b>	<b>8-37</b>



## TROUBLESHOOTING

## FI SYSTEM MALFUNCTION CODE AND DEFECTIVE CONDITION

MALFUNCTION CODE	DETECTED ITEM	DETECTED FAILURE CONDITION
		CHECK FOR
c00	NO FAULT	
c11	Camshaft position sensor	The signal does not reach ECM for more than 4 sec. after receiving the starter signal.
		The camshaft position sensor wiring and mechanical parts. (Camshaft position sensor, intake cam pin, wiring/coupler connection)
c12	Crankshaft position sensor	The signal does not reach ECM for more than 3 sec. after receiving the starter signal.
		The crankshaft position sensor wiring and mechanical parts. (Crankshaft position sensor, wiring/coupler connection)
c13	Intake air pressure sensor	The sensor should produce following voltage. ( $0.20\text{ V} \leq \text{sensor voltage} < 4.80\text{ V}$ ) Without the above range, c13 is indicated.
		Intake air pressure sensor, wiring/coupler connection.
c14	Throttle position sensor	The sensor should produce following voltage. ( $0.20\text{ V} \leq \text{sensor voltage} < 4.80\text{ V}$ ) Without the above range, c14 is indicated.
		Throttle position sensor, wiring/coupler connection.
c15	Engine oil temperature sensor	The sensor voltage should be the following. ( $0.26\text{ V} \leq \text{sensor voltage} < 4.77\text{ V}$ ) Without the above range, c15 is indicated.
		Engine oil temperature sensor, wiring/coupler connection.
c21	Intake air temperature sensor	The sensor voltage should be the following. ( $0.17\text{ V} \leq \text{sensor voltage} < 4.60\text{ V}$ ) Without the above range, c21 is indicated.
		Intake air temperature sensor, wiring/coupler connection.
c22	Atmospheric pressure sensor	The sensor voltage should be the following. ( $0.20\text{ V} \leq \text{sensor voltage} < 4.80\text{ V}$ ) Without the above range, c22 is indicated.
		Atm. pressure sensor, wiring/coupler connection.
c23	Tip over sensor	The sensor voltage should be less than the following for more than 4 sec. after ignition switch turns ON. (Sensor voltage $< 3.90\text{ V}$ ) Without the above value, c23 is indicated.
		Tip over sensor, wiring/coupler connection.
c24 or c25	Ignition signal	Crankshaft position sensor (pick-up coil) signal is produced but signal from ignition coil is interrupted continuous by two times or more. In this case, the code c24 or c25 is indicated.
		Ignition coil, wiring/coupler connection, power supply from the battery.



c28	Secondary throttle valve actuator	When no actuator control signal is supplied from ECM or communication signal does not reach ECM or operation voltage does not reach STVA motor, c28 is indicated. STVA can not operate. ----- STVA lead wire/coupler.
c29	Secondary throttle position sensor	The sensor should produce following voltage. ( $0.20\text{ V} \leq \text{sensor voltage} < 4.80\text{ V}$ ) Without the above range, c29 is indicated. ----- Secondary throttle position sensor, wiring/coupler connection.
c31	Gear position signal	Gear position signal voltage should be higher than the following for more than 4 seconds. (Gear position sensor voltage $> 0.60\text{ V}$ ) Without the above value, c31 is indicated. ----- Gear position sensor, wiring/coupler connection. Gearshift cam etc.
c32, c33, c34 or c35	Fuel injector signal	When fuel injection signal stops, the c32, c33, c34 or c35 is indicated. ----- Injector, wiring/coupler connection, power supply to the injector.
c41	Fuel pump relay signal	When no signal is supplied from fuel pump relay, c41 is indicated. ----- Fuel pump relay, connecting lead, power source to fuel pump relay.
c42	Ignition switch signal	Ignition switch signal is not input in the ECM. ----- Ignition switch, lead wire/coupler.



Complaint	Symptom and possible causes	Remedy
<b>Engine idles poorly.</b>	<ol style="list-style-type: none"> <li>1. Out of adjustment valve clearance.</li> <li>2. Poor seating of valves.</li> <li>3. Defective valve guides.</li> <li>4. Worn down camshaft.</li> <li>5. Too wide spark plug gaps.</li> <li>6. Defective ignition coil or plug cap.</li> <li>7. Defective crankshaft position sensor.</li> <li>8. Defective ECM.</li> <li>9. Defective throttle position sensor.</li> <li>10. Defective fuel pump.</li> <li>11. Imbalanced throttle valve.</li> <li>12. Damaged or cracked vacuum hose.</li> </ol>	<p>Adjust.            Replace or repair.            Replace.            Replace.            Adjust or replace.            Replace.            Replace.            Replace.            Replace.            Replace.            Adjust.            Replace.</p>
<b>Engine stalls easily.</b>	<p><b>Incorrect fuel/air mixture</b></p> <ol style="list-style-type: none"> <li>1. Defective intake air pressure sensor or circuit.</li> <li>2. Clogged fuel filter.</li> <li>3. Defective fuel pump.</li> <li>4. Defective fuel pressure regulator.</li> <li>5. Defective engine oil temp. sensor.</li> <li>6. Defective intake air temp. sensor.</li> </ol> <p><b>Improperly working fuel injector</b></p> <ol style="list-style-type: none"> <li>1. Defective fuel injector.</li> <li>2. No injection signal from ECM.</li> <li>3. Open or short circuited wiring connection.</li> <li>4. Defective battery or low battery voltage.</li> </ol> <p><b>Improperly working control circuit or sensors</b></p> <ol style="list-style-type: none"> <li>1. Defective ECM.</li> <li>2. Defective fuel pressure regulator.</li> <li>3. Defective throttle position sensor.</li> <li>4. Defective intake air temp. sensor.</li> <li>5. Defective camshaft position sensor.</li> <li>6. Defective crankshaft position sensor.</li> <li>7. Defective engine oil temp. sensor.</li> <li>8. Defective fuel pump relay.</li> </ol> <p><b>Improperly working engine internal parts</b></p> <ol style="list-style-type: none"> <li>1. Fouled spark plugs.</li> <li>2. Defective crankshaft position sensor or ECM.</li> <li>3. Clogged fuel hose.</li> <li>4. Out of adjustment tappet clearance.</li> </ol>	<p>Repair or replace.            Clean or replace.            Replace.            Replace.            Replace.            Replace.            Replace.            Replace.            Replace.            Replace.            Replace or recharge.            Replace.            Replace.            Replace.            Replace.            Replace.            Replace.            Replace.            Replace.            Replace.            Clean.            Replace.            Clean.            Adjust.</p>

Complaint	Symptom and possible causes	Remedy
<b>Noisy engine.</b>	<p><b>Excessive valve chatter</b></p> <ol style="list-style-type: none"> <li>1. Too large valve clearance.</li> <li>2. Weakened or broken valve springs.</li> <li>3. Worn tappet or cam surface.</li> <li>4. Worn and burnt camshaft journal.</li> </ol> <p><b>Noise seems to come from piston</b></p> <ol style="list-style-type: none"> <li>1. Worn down pistons or cylinders.</li> <li>2. Fouled with carbon combustion chambers.</li> <li>3. Worn piston pins or piston pin bore.</li> <li>4. Worn piston rings or ring grooves.</li> </ol> <p><b>Noise seems to come from timing chain</b></p> <ol style="list-style-type: none"> <li>1. Stretched chain.</li> <li>2. Worn sprockets.</li> <li>3. Not working tension adjuster.</li> </ol> <p><b>Noise seems to come from clutch</b></p> <ol style="list-style-type: none"> <li>1. Worn splines of countershaft or hub.</li> <li>2. Worn teeth of clutch plates.</li> <li>3. Distorted clutch plates, driven and drive.</li> <li>4. Worn clutch release bearing.</li> <li>5. Weakened clutch dampers.</li> </ol> <p><b>Noise seems to come from crankshaft</b></p> <ol style="list-style-type: none"> <li>1. Due to wear rattling bearings.</li> <li>2. Worn and burnt big-end bearings.</li> <li>3. Worn and burnt journal bearings.</li> <li>4. Too large thrust clearance.</li> </ol> <p><b>Noise seems to come from balancer</b></p> <ol style="list-style-type: none"> <li>1. Worn and burnt journal bearings.</li> </ol> <p><b>Noise seems to come from transmission</b></p> <ol style="list-style-type: none"> <li>1. Worn or rubbing gears.</li> <li>2. Worn splines.</li> <li>3. Worn or rubbing primary gears.</li> <li>4. Worn bearings.</li> </ol>	<p>Adjust. Replace. Replace. Replace.</p> <p>Replace. Clean, Replace. Replace.</p> <p>Replace. Replace. Repair or replace.</p> <p>Replace. Replace. Replace. Replace. Replace the primary driven gear.</p> <p>Replace. Replace. Replace. Replace thrust bearing.</p> <p>Replace.</p> <p>Replace. Replace. Replace. Replace.</p>
<b>Engine runs poorly in high speed range.</b>	<p><b>Defective engine internal/electrical parts</b></p> <ol style="list-style-type: none"> <li>1. Weakened valve springs.</li> <li>2. Worn camshafts.</li> <li>3. Valve timing out of adjustment.</li> <li>4. Too narrow spark plug gaps.</li> <li>5. Ignition not advanced sufficiently due to poorly working timing advance circuit.</li> <li>6. Defective ignition coil.</li> <li>7. Defective crankshaft position sensor.</li> <li>8. Defective ECM.</li> <li>9. Clogged air cleaner element.</li> <li>10. Clogged fuel hose, resulting in inadequate fuel supply to injector.</li> <li>11. Defective fuel pump.</li> <li>12. Defective throttle position sensor.</li> <li>13. Defective STP sensor or STV actuator</li> </ol>	<p>Replace. Replace. Adjust. Adjust. Replace ECM.</p> <p>Replace. Replace. Replace. Clean, Clean and prime.</p> <p>Replace. Replace. Replace.</p>

Complaint	Symptom and possible causes	Remedy
<p><b>Engine runs poorly in high speed range.</b></p>	<p><b>Defective air flow system</b></p> <ol style="list-style-type: none"> <li>1. Clogged air cleaner element.</li> <li>2. Defective throttle valve.</li> <li>3. Defective secondary throttle valve.</li> <li>4. Sucking air from throttle body joint.</li> <li>5. Defective ECM.</li> <li>6. Imbalancing throttle valve synchronization.</li> </ol> <p><b>Defective control circuit or sensor</b></p> <ol style="list-style-type: none"> <li>1. Low fuel pressure.</li> <li>2. Defective throttle position sensor.</li> <li>3. Defective intake air temp. sensor.</li> <li>4. Defective camshaft position sensor.</li> <li>5. Defective crankshaft position sensor.</li> <li>6. Defective gear position sensor.</li> <li>7. Defective intake air pressure sensor.</li> <li>8. Defective atmospheric pressure sensor.</li> <li>9. Defective ECM.</li> <li>10. Out of adjustment throttle position sensor.</li> <li>11. Defective STP sensor and/or STV actuator.</li> </ol>	<p>Clean or replace. Adjust or replace. Adjust or replace. Repair or replace. Replace. Adjust.</p> <p>Repair or replace. Replace. Replace. Replace. Replace. Replace. Replace. Replace. Replace. Adjust. Replace.</p>
<p><b>Engine lacks power.</b></p>	<p><b>Defective engine internal/electrical parts</b></p> <ol style="list-style-type: none"> <li>1. Loss of valve clearance.</li> <li>2. Weakened valve springs.</li> <li>3. Out of adjustment valve timing.</li> <li>4. Worn piston rings or cylinders.</li> <li>5. Poor seating of valves.</li> <li>6. Fouled spark plug.</li> <li>7. Incorrect spark plug.</li> <li>8. Clogged injector.</li> <li>9. Out of adjustment throttle position sensor.</li> <li>10. Clogged air cleaner element.</li> <li>11. Imbalancing throttle valve synchronization.</li> <li>12. Sucking air from throttle valve or vacuum hose.</li> <li>13. Too much engine oil.</li> <li>14. Defective fuel pump or ECM.</li> <li>15. Defective crankshaft position sensor and ignition coil.</li> </ol> <p><b>Defective control circuit or sensor</b></p> <ol style="list-style-type: none"> <li>1. Low fuel pressure.</li> <li>2. Defective throttle position sensor.</li> <li>3. Defective intake air temp. sensor.</li> <li>4. Defective camshaft position sensor.</li> <li>5. Defective crankshaft position sensor.</li> <li>6. Defective gear position sensor.</li> <li>7. Defective intake air pressure sensor.</li> <li>8. Defective atmospheric pressure sensor.</li> <li>9. Defective ECM.</li> <li>10. Out of adjustment throttle position sensor.</li> <li>11. Defective STP sensor and/or STV actuator.</li> </ol>	<p>Adjust. Replace. Adjust. Replace. Repair. Clean or replace. Adjust or replace. Clean. Adjust. Clean. Adjust. Retighten or replace. Drain out excess oil. Replace. Replace.</p> <p>Repair or replace. Replace. Replace. Replace. Replace. Replace. Replace. Replace. Replace. Adjust. Replace.</p>

Complaint	Symptom and possible causes	Remedy
<b>Engine overheats.</b>	<p><b>Defective engine internal parts</b></p> <ol style="list-style-type: none"> <li>1. Heavy carbon deposit on piston crowns.</li> <li>2. Not enough oil in the engine.</li> <li>3. Defective oil pump or clogged oil circuit.</li> <li>4. Sucking air from intake pipes.</li> <li>5. Use incorrect engine oil.</li> <li>6. Defective cooling system.</li> </ol> <p><b>Lean fuel/air mixture</b></p> <ol style="list-style-type: none"> <li>1. Short-circuited intake air pressure sensor/lead wire.</li> <li>2. Short-circuited intake air temp. sensor/lead wire.</li> <li>3. Sucking air from intake pipe joint.</li> <li>4. Defective fuel injector.</li> <li>5. Defective engine oil temp. sensor.</li> </ol> <p><b>The other factors</b></p> <ol style="list-style-type: none"> <li>1. Ignition timing is too advanced due to defective timing advance system (engine coolant temp. sensor, gear position sensor, crankshaft position sensor and ECM.)</li> <li>2. Drive chain is too tight.</li> </ol>	<p>Clean. Add oil. Replace or clean. Retighten or replace. Change. See cooling section.</p> <p>Repair or replace.</p> <p>Repair or replace. Clean or replace. Repair or replace. Replace.</p> <p>Replace.</p> <p>Adjust.</p>
<b>Dirty or heavy exhaust smoke.</b>	<ol style="list-style-type: none"> <li>1. Too much engine oil in the engine.</li> <li>2. Worn piston rings or cylinders.</li> <li>3. Worn valve guides.</li> <li>4. Scored or scuffed cylinder walls.</li> <li>5. Worn valves stems.</li> <li>6. Defective stem seal.</li> <li>7. Worn oil ring side rails.</li> </ol>	<p>Check with inspection window drain out excess oil. Replace. Replace. Replace. Replace. Replace. Replace.</p>
<b>Slipping clutch.</b>	<ol style="list-style-type: none"> <li>1. Weakened clutch springs.</li> <li>2. Worn or distorted pressure plate.</li> <li>3. Distorted clutch plates or clutch plate.</li> </ol>	<p>Replace. Replace. Replace.</p>
<b>Dragging clutch.</b>	<ol style="list-style-type: none"> <li>1. Some clutch spring weakened while others are not.</li> <li>2. Distorted pressure plate or clutch plate.</li> </ol>	<p>Replace. Replace.</p>
<b>Transmission will not shift.</b>	<ol style="list-style-type: none"> <li>1. Broken gearshift cam.</li> <li>2. Distorted gearshift forks.</li> <li>3. Worn gearshift pawl.</li> </ol>	<p>Replace. Replace. Replace.</p>
<b>Transmission will not shift back.</b>	<ol style="list-style-type: none"> <li>1. Broken return spring on shift shaft.</li> <li>2. Rubbing or sticky shift shaft.</li> <li>3. Distorted or worn gearshift forks.</li> </ol>	<p>Replace. Repair or replace. Replace.</p>
<b>Transmission jumps out of gear.</b>	<ol style="list-style-type: none"> <li>1. Worn shifting gears on driveshaft or countershaft.</li> <li>2. Distorted or worn gearshift forks.</li> <li>3. Weakened stopper spring on gearshift stopper.</li> <li>4. Worn gearshift cam plate.</li> </ol>	<p>Replace. Replace. Replace. Replace.</p>

**COOLING SYSTEM**

<b>Complaint</b>	<b>Symptom and possible causes</b>	<b>Remedy</b>
<b>Engine overheats.</b>	<ol style="list-style-type: none"> <li>1. Not enough engine oil.</li> <li>2. Clogged with dirt or trashes oil cooler core.</li> <li>3. Faulty cooling fan.</li> <li>4. Defective cooling fan thermo-switch.</li> <li>5. Clogged oil passage.</li> <li>6. Air trapped in the cooling circuit.</li> <li>7. Defective oil pump.</li> <li>8. Use incorrect oil.</li> <li>9. Defective oil relief valve or oil pressure regulator.</li> </ol>	<p>Add oil.</p> <p>Clean.</p> <p>Repair or replace.</p> <p>Replace.</p> <p>Clean.</p> <p>Bleed out air.</p> <p>Replace.</p> <p>Replace.</p> <p>Replace.</p>
<b>Engine overcools.</b>	<ol style="list-style-type: none"> <li>1. Defective cooling fan thermo-switch.</li> <li>2. Extremely cold weather.</li> <li>3. Defective oil relief valve or oil pressure regulator.</li> </ol>	<p>Replace.</p> <p>Put on the oil cooler cover.</p> <p>Replace.</p>



## CHASSIS

Complaint	Symptom and possible causes	Remedy
<b>Heavy steering.</b>	<ol style="list-style-type: none"> <li>1. Overtightened steering stem nut.</li> <li>2. Broken bearing in steering stem.</li> <li>3. Distorted steering stem.</li> <li>4. Not enough pressure in tires.</li> </ol>	Adjust. Replace. Replace. Adjust.
<b>Wobbly handlebars.</b>	<ol style="list-style-type: none"> <li>1. Loss of balance between right and left front forks.</li> <li>2. Distorted front fork.</li> <li>3. Distorted front axle or crooked tire.</li> <li>4. Loose steering stem nut.</li> <li>5. Worn or incorrect tire or wrong tire pressure.</li> <li>6. Worn bearing/race in steering stem.</li> </ol>	Adjust. Repair or replace. Replace. Adjust. Adjust or replace. Replace.
<b>Wobbly front wheel.</b>	<ol style="list-style-type: none"> <li>1. Distorted wheel rim.</li> <li>2. Worn front wheel bearings.</li> <li>3. Defective or incorrect tire. Replace.</li> <li>4. Loose axle or axle pinch bolt.</li> <li>5. Incorrect front fork oil level.</li> </ol>	Replace. Replace.  Retighten. Adjust.
<b>Front suspension too soft.</b>	<ol style="list-style-type: none"> <li>1. Weakened springs.</li> <li>2. Not enough fork oil.</li> <li>3. Wrong weight fork oil.</li> <li>4. Improperly set front fork spring adjuster.</li> <li>5. Improperly set front fork damping force adjuster.</li> </ol>	Replace. Replenish. Replace. Adjust. Adjust.
<b>Front suspension too stiff.</b>	<ol style="list-style-type: none"> <li>1. Too viscous fork oil.</li> <li>2. Too much fork oil.</li> <li>3. Improperly set front fork spring adjuster.</li> <li>4. Improperly set front fork damping force adjuster.</li> <li>5. Bent front axle.</li> </ol>	Replace. Drain excess oil. Adjust. Adjust. Replace.
<b>Noisy front suspension.</b>	<ol style="list-style-type: none"> <li>1. Not enough fork oil.</li> <li>2. Loose bolts on suspension.</li> </ol>	Replenish. Retighten.
<b>Wobbly rear wheel.</b>	<ol style="list-style-type: none"> <li>1. Distorted wheel rim.</li> <li>2. Worn rear wheel bearing or swingarm bearings.</li> <li>3. Defective or incorrect tire. Replace.</li> <li>4. Worn swingarm and rear suspension bearings.</li> <li>5. Loose nuts or bolts on rear suspensions.</li> </ol>	Replace. Replace.  Replace. Retighten.
<b>Rear suspension too soft.</b>	<ol style="list-style-type: none"> <li>1. Weakened spring of shock absorber.</li> <li>2. Leakage oil or gas of shock absorber.</li> <li>3. Improperly set rear spring pre-load adjuster.</li> <li>4. Improperly set damping force adjuster.</li> </ol>	Replace. Replace. Adjust. Adjust.
<b>Rear suspension too stiff.</b>	<ol style="list-style-type: none"> <li>1. Bent shock absorber shaft.</li> <li>2. Bent swingarm.</li> <li>3. Worn swingarm and rear suspension bearings.</li> <li>4. Improperly set rear spring pre-load adjuster.</li> <li>5. Improperly set damping force adjuster.</li> </ol>	Replace. Replace. Replace. Adjust. Adjust.
<b>Noisy rear suspension.</b>	<ol style="list-style-type: none"> <li>1. Loose nuts or bolts on rear suspension.</li> <li>2. Worn swingarm and suspension bearings.</li> </ol>	Retighten. Replace.

## BRAKES

Complaint	Symptom and possible causes	Remedy
<b>Insufficient brake power.</b>	<ol style="list-style-type: none"> <li>1. Leakage of brake fluid from hydraulic system.</li> <li>2. Worn pads.</li> <li>3. Oil adhesion of engaging surface of pads/shoe.</li> <li>4. Worn disc.</li> <li>5. Air in hydraulic system.</li> <li>6. Not enough brake fluid in the reservoir.</li> </ol>	Repair or replace. Replace. Clean disc and pads. Replace. Bleed air. Replenish.
<b>Brake squeaking.</b>	<ol style="list-style-type: none"> <li>1. Carbon adhesion on pad surface.</li> <li>2. Tilted pad.</li> <li>3. Damaged wheel bearing.</li> <li>4. Loosen front-wheel axle or rear-wheel axle.</li> <li>5. Worn pads.</li> <li>6. Foreign material in brake fluid.</li> <li>7. Clogged return port of master cylinder.</li> </ol>	Repair surface with sandpaper. Modify pad fitting or replace. Replace. Tighten to specified torque. Replace. Replace brake fluid. Disassemble and clean master cylinder.
<b>Excessive brake lever stroke.</b>	<ol style="list-style-type: none"> <li>1. Air in hydraulic system.</li> <li>2. Insufficient brake fluid.</li> <li>3. Improper quality of brake fluid.</li> </ol>	Bleed air. Replenish fluid to specified level; bleed air. Replace with correct fluid.
<b>Leakage of brake fluid</b>	<ol style="list-style-type: none"> <li>1. Insufficient tightening of connection joints.</li> <li>2. Cracked hose.</li> <li>3. Worn piston and/or cup.</li> </ol>	Tighten to specified torque. Replace. Replace piston and/or cup.
<b>Brake drags.</b>	<ol style="list-style-type: none"> <li>1. Rusty part.</li> <li>2. Insufficient brake lever or brake pedal pivot lubrication.</li> </ol>	Clean and lubricate. Lubricate.

## ELECTRICAL

Complaint	Symptom and possible causes	Remedy
<b>No sparking or poor sparking.</b>	<ol style="list-style-type: none"> <li>1. Defective ignition coil or plug cap or camshaft position sensor.</li> <li>2. Defective spark plugs.</li> <li>3. Defective crankshaft position sensor.</li> <li>4. Defective ECM.</li> <li>5. Defective tip over sensor.</li> <li>6. Open-circuited wiring connections.</li> </ol>	<p>Replace.</p> <p>Replace.</p> <p>Replace.</p> <p>Replace.</p> <p>Replace.</p> <p>Check and repair.</p>
<b>Spark plug soon become fouled with carbon.</b>	<ol style="list-style-type: none"> <li>1. Mixture too rich.</li> <li>2. Idling speed set too high.</li> <li>3. Incorrect gasoline.</li> <li>4. Dirty element in air cleaner.</li> <li>5. Too cold spark plugs.</li> </ol>	<p>Inspect FI system.</p> <p>Adjust fast idle or throttle stop screw.</p> <p>Change.</p> <p>Clean or replace.</p> <p>Replace with hot type plugs.</p>
<b>Spark plugs become fouled too soon.</b>	<ol style="list-style-type: none"> <li>1. Worn piston rings.</li> <li>2. Worn piston or cylinders.</li> <li>3. Excessive clearance of valve stems in valve guides.</li> <li>4. Worn stem oil seal.</li> </ol>	<p>Replace.</p> <p>Replace.</p> <p>Replace.</p> <p>Replace.</p>
<b>Spark plug electrodes overheat or burn.</b>	<ol style="list-style-type: none"> <li>1. Too hot spark plugs.</li> <li>2. Loose spark plugs.</li> <li>3. Too lean mixture.</li> </ol>	<p>Replace with cold type plugs.</p> <p>Retighten.</p> <p>Inspect FI system.</p>
<b>Generator does not charge.</b>	<ol style="list-style-type: none"> <li>1. Open or short lead wires, or loose lead connections.</li> <li>2. Shorted, grounded or open generator coils.</li> <li>3. Shorted or punctured regulator/rectifiers.</li> </ol>	<p>Repair or replace or retighten.</p> <p>Replace.</p> <p>Replace.</p>
<b>Generator does charge, but charging rate is below the specification.</b>	<ol style="list-style-type: none"> <li>1. Lead wires tend to get shorted or open-circuited or loosely connected at terminals.</li> <li>2. Grounded or open-circuited stator coils or generator.</li> <li>3. Defective regulator/rectifier.</li> <li>4. Defective cell plates in the battery.</li> </ol>	<p>Repair or retighten.</p> <p>Replace.</p> <p>Replace.</p> <p>Replace the battery.</p>
<b>Generator overcharges.</b>	<ol style="list-style-type: none"> <li>1. Internal short-circuit in the battery.</li> <li>2. Damaged or defective regulator/rectifier.</li> <li>3. Poorly grounded regulator/rectifier.</li> </ol>	<p>Replace the battery.</p> <p>Replace.</p> <p>Repair, replace, or connect properly.</p>
<b>Unstable charging.</b>	<ol style="list-style-type: none"> <li>1. Lead wire insulation frayed due to vibration, resulting in intermittent shorting.</li> <li>2. Internally shorted generator.</li> <li>3. Defective regulator/rectifier.</li> </ol>	<p>Repair or replace.</p> <p>Replace.</p> <p>Replace.</p>
<b>Starter button is not effective.</b>	<ol style="list-style-type: none"> <li>1. Run down battery.</li> <li>2. Defective switch contacts.</li> <li>3. Not seating properly brushes on commutator in starter motor.</li> <li>4. Defective starter relay/starter interlock switch.</li> <li>5. Defective main fuse.</li> </ol>	<p>Repair or replace.</p> <p>Replace.</p> <p>Repair or replace.</p> <p>Replace.</p> <p>Replace.</p>

**BATTERY**

Complaint	Symptom and possible causes	Remedy
<b>"Sulfation", acidic white powdery substance or spots on surface of cell plates.</b>	<ol style="list-style-type: none"> <li>1. Cracked battery case.</li> <li>2. Battery has been left in a run-down condition for a long time.</li> </ol>	<p>Replace the battery.</p> <p>Replace the battery.</p>
<b>Battery runs down quickly.</b>	<ol style="list-style-type: none"> <li>1. Not correct the charging system.</li> <li>2. Cell plates have lost much of their active material as a result of overcharging.</li> <li>3. Internal short-circuit in the battery.</li> <li>4. Too low battery voltage.</li> <li>5. Too old battery.</li> </ol>	<p>Check the generator, regulator/rectifier and circuit connections and make necessary adjustments to obtain specified charging operation.</p> <p>Replace the battery, and correct the charging system.</p> <p>Replace the battery.</p> <p>Recharge the battery fully.</p> <p>Replace the battery.</p>
<b>Battery "sulfation".</b>	<ol style="list-style-type: none"> <li>1. Incorrect charging rate. (When not in use batteries should be checked at least once a month to avoid sulfation.)</li> <li>2. The battery was left un used in a cold climate for too long.</li> </ol>	<p>Replace the battery.</p> <p>Replace the battery if badly sulfated.</p>



# FI SYSTEM WIRING DIAGRAM

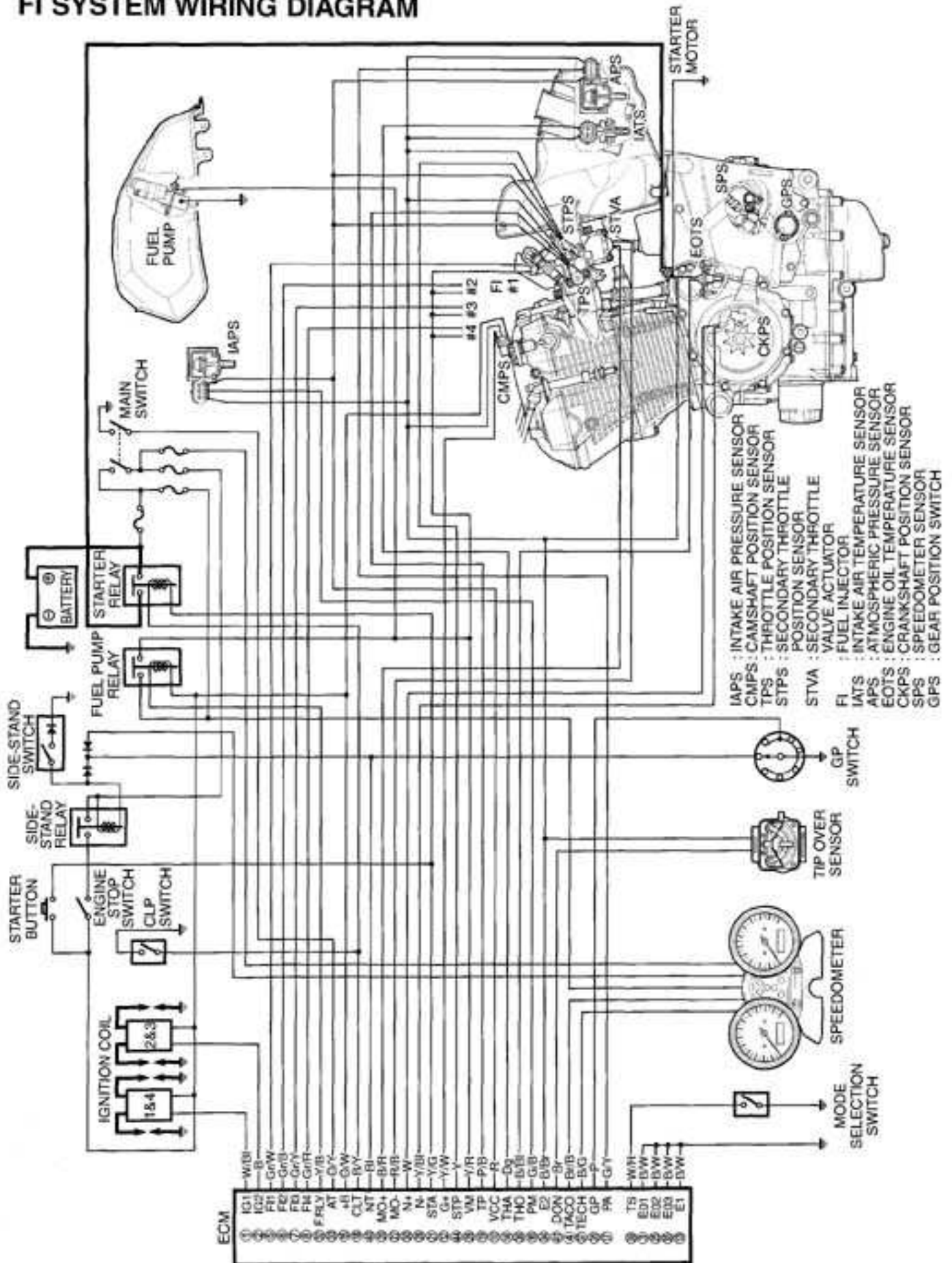

# WIRING HARNESS, CABLE AND HOSE ROUTING

## WIRING HARNESS ROUTING

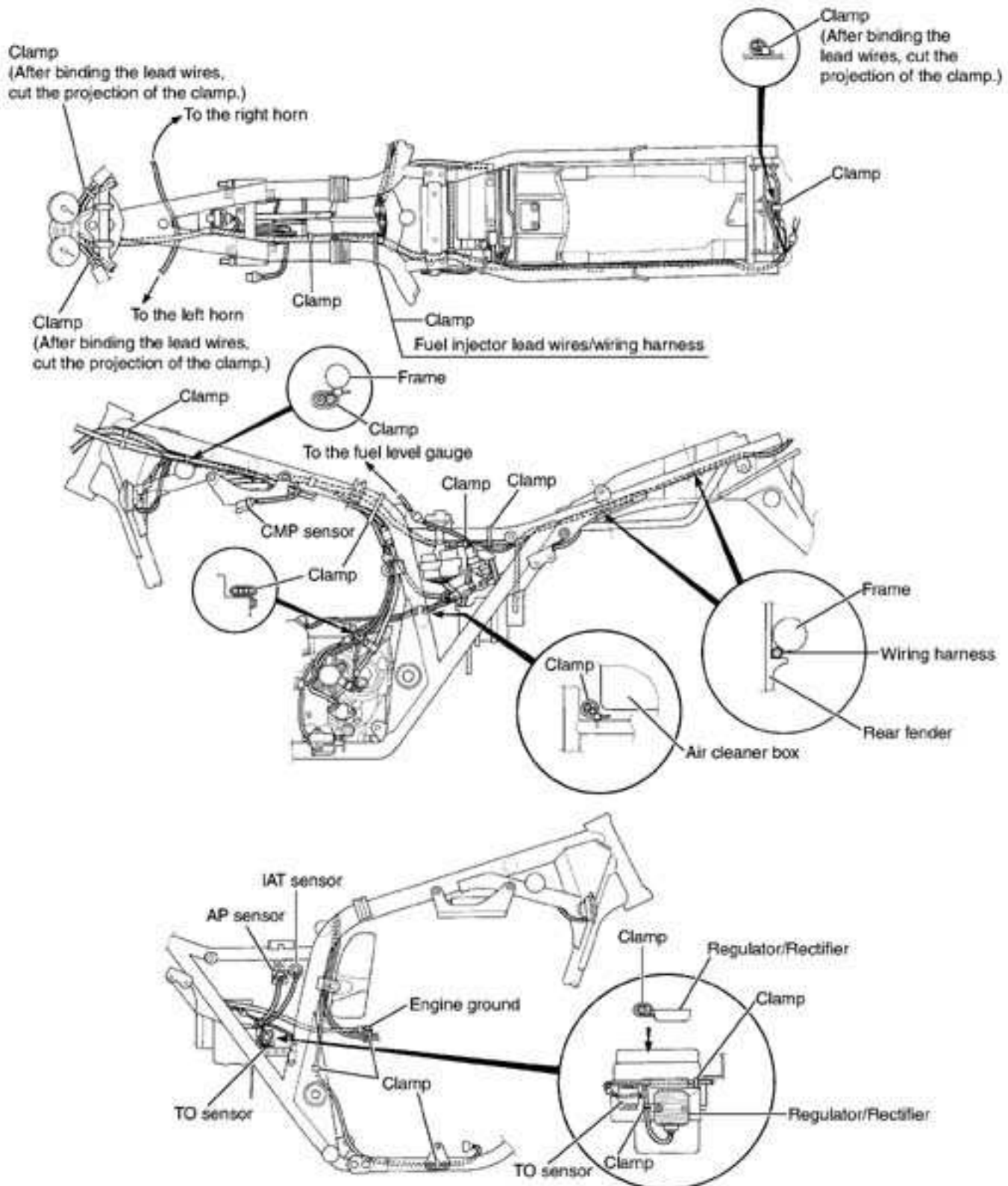



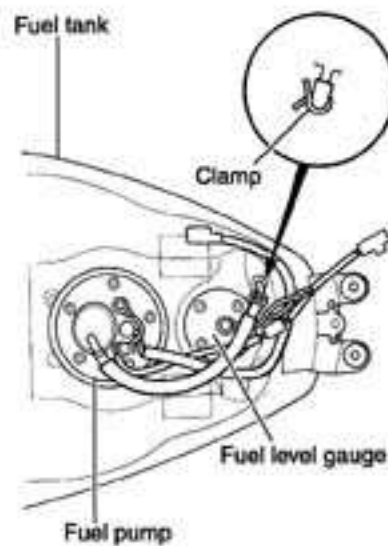
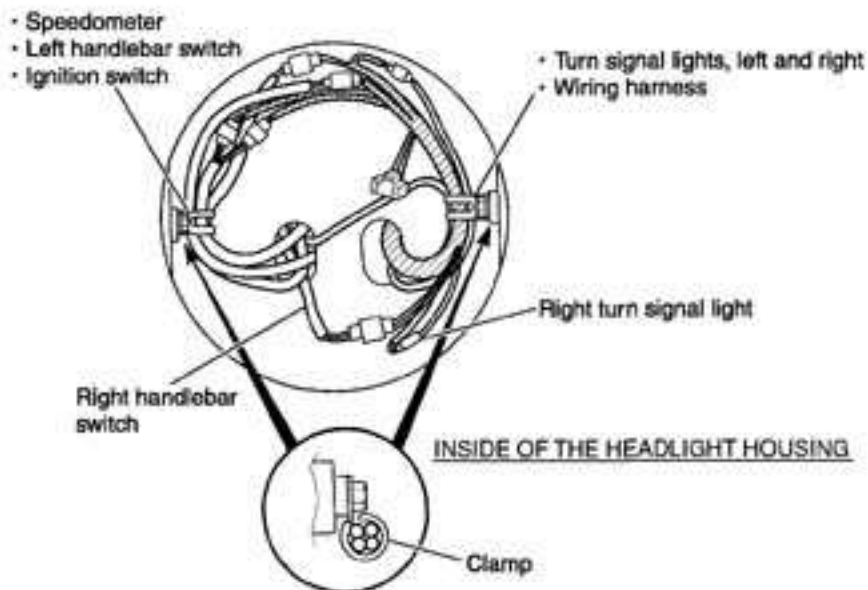

### HIGH-TENSION CORD ROUTING

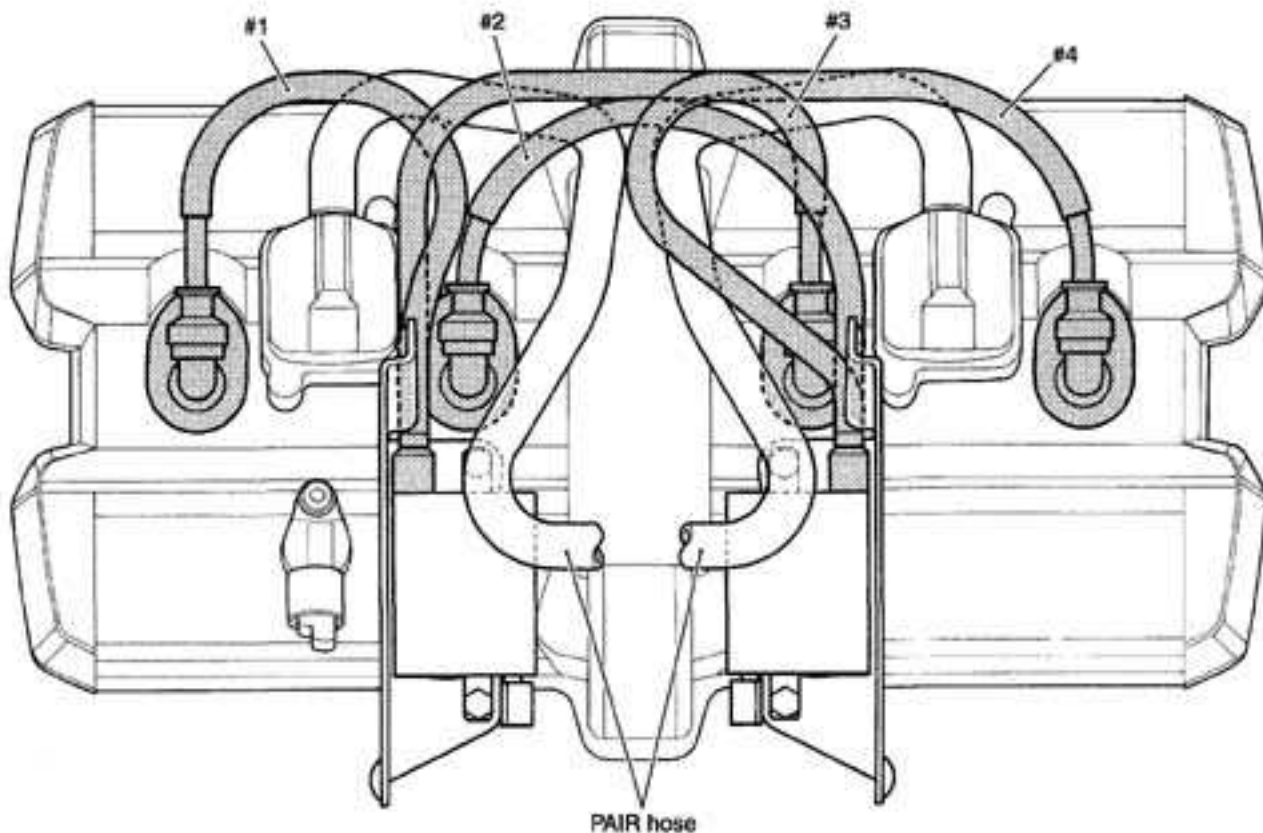

## ENGINE ELECTRICAL PARTS SET-UP

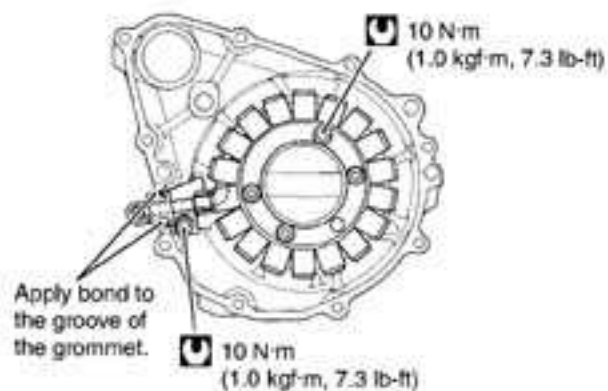
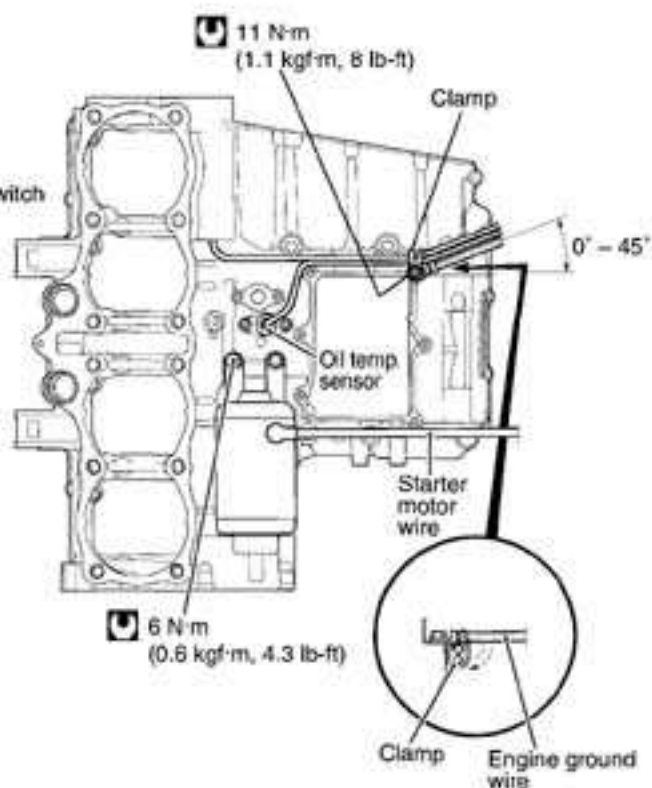
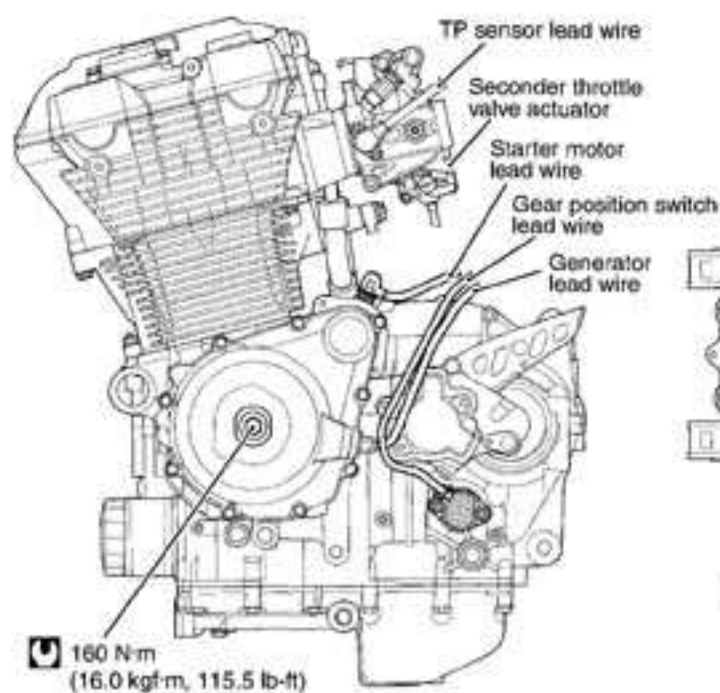
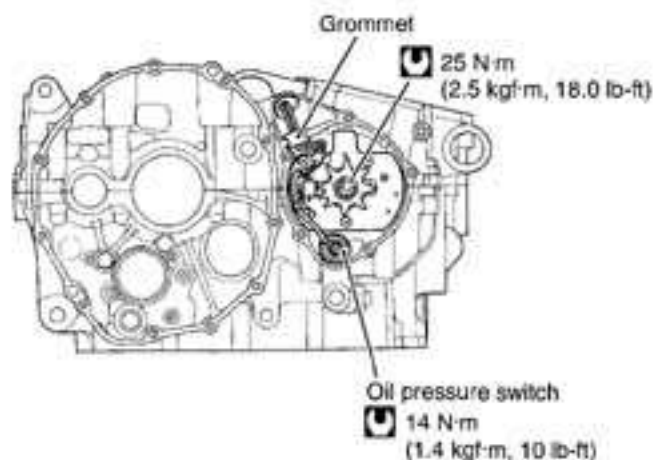
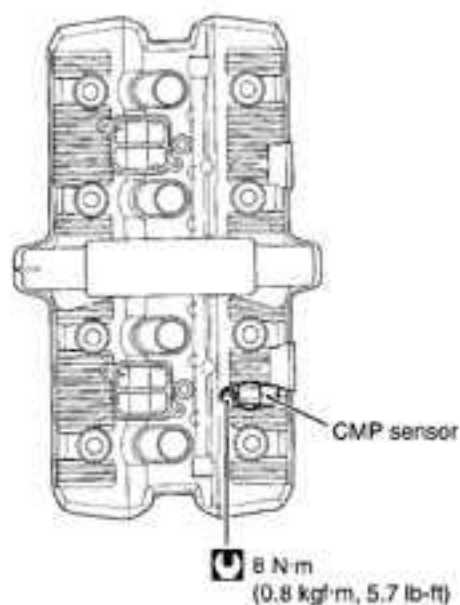

## CLUTCH HOSE ROUTING

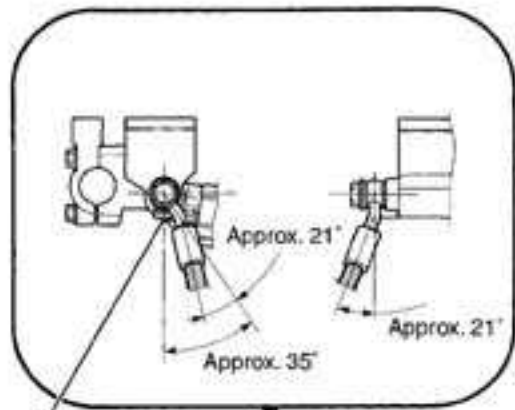

After touching the hose union to the stopper, tighten the union bolt.

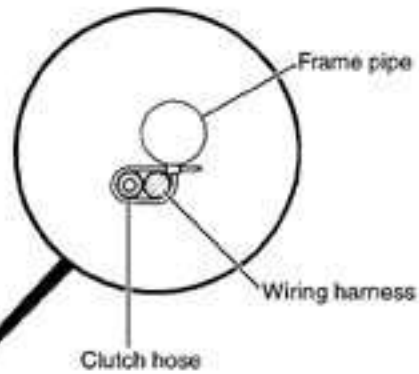

Pass through the clutch hose behind the ignition coil bracket.

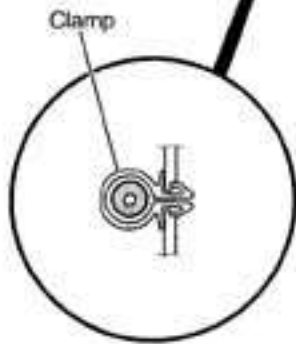

Clamp

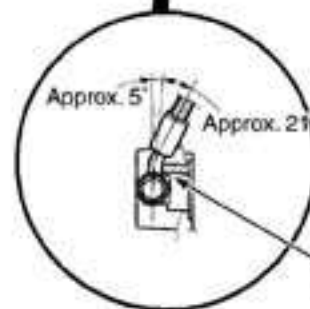

After touching the hose union to the stopper, tighten the union bolt.

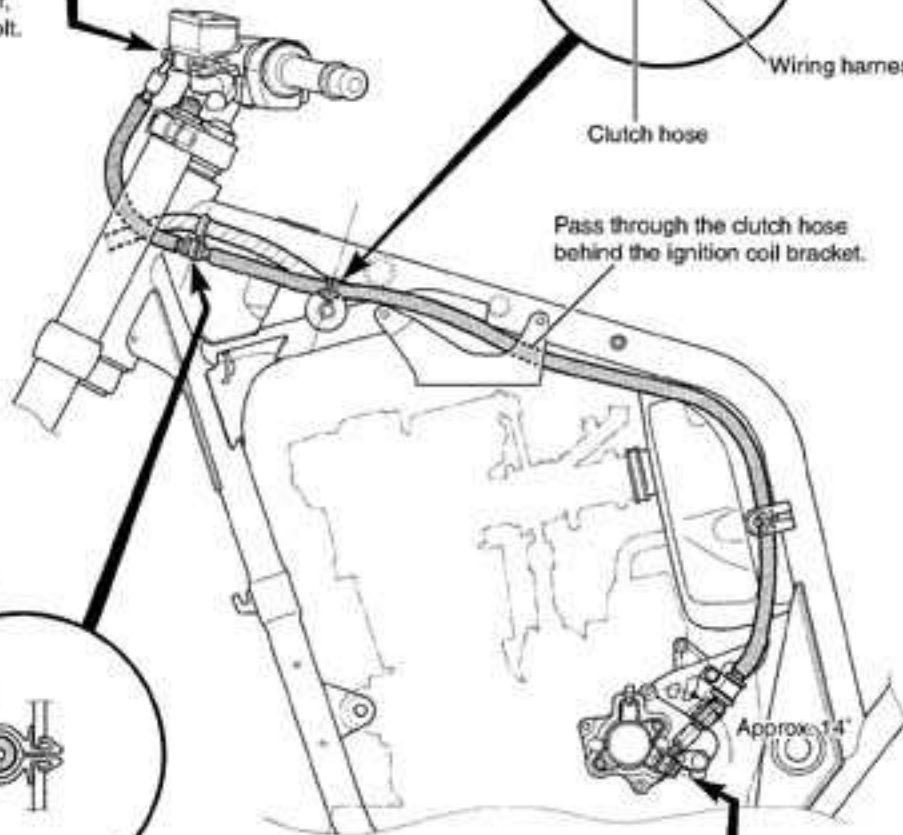

## THROTTLE CABLE ROUTING

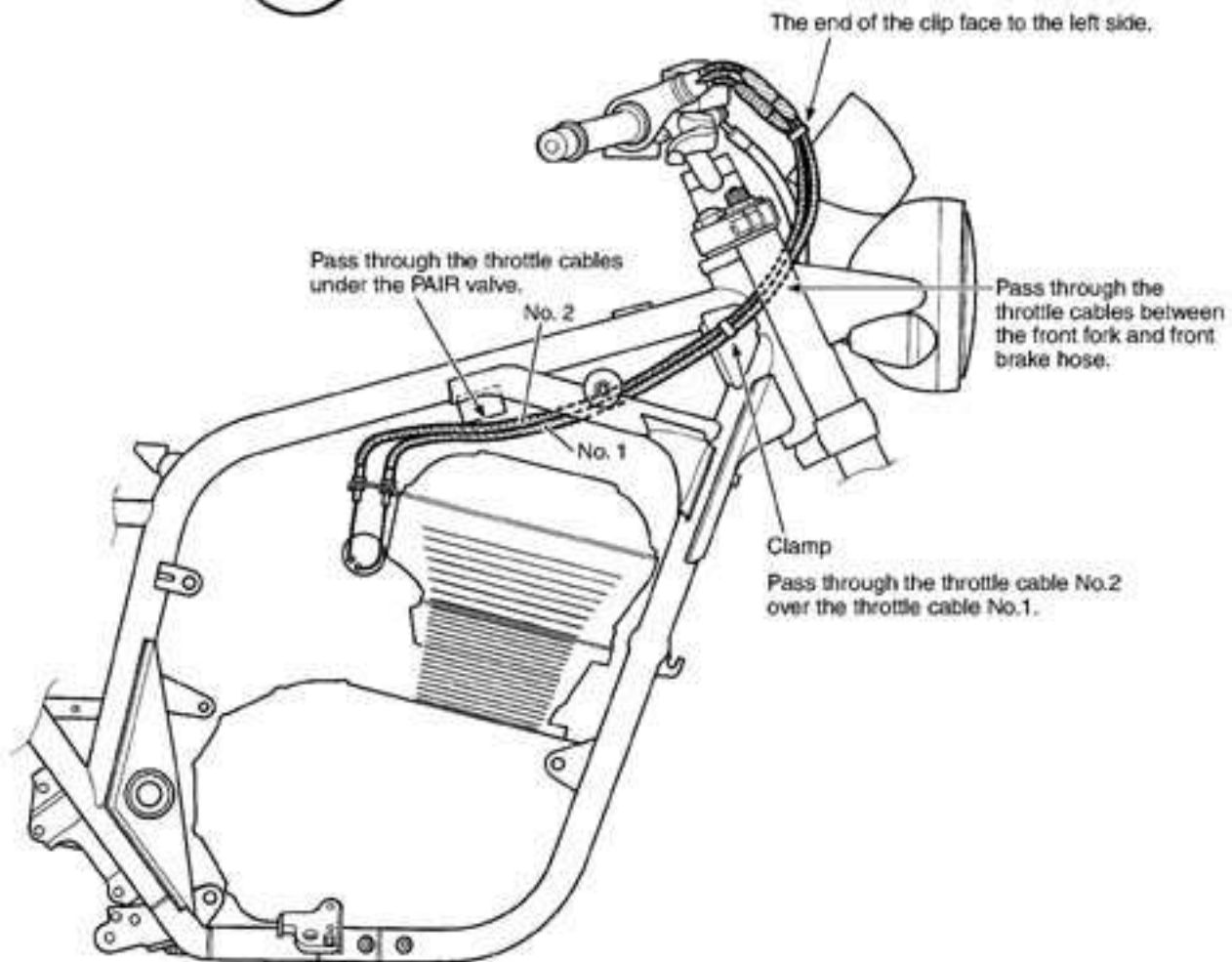
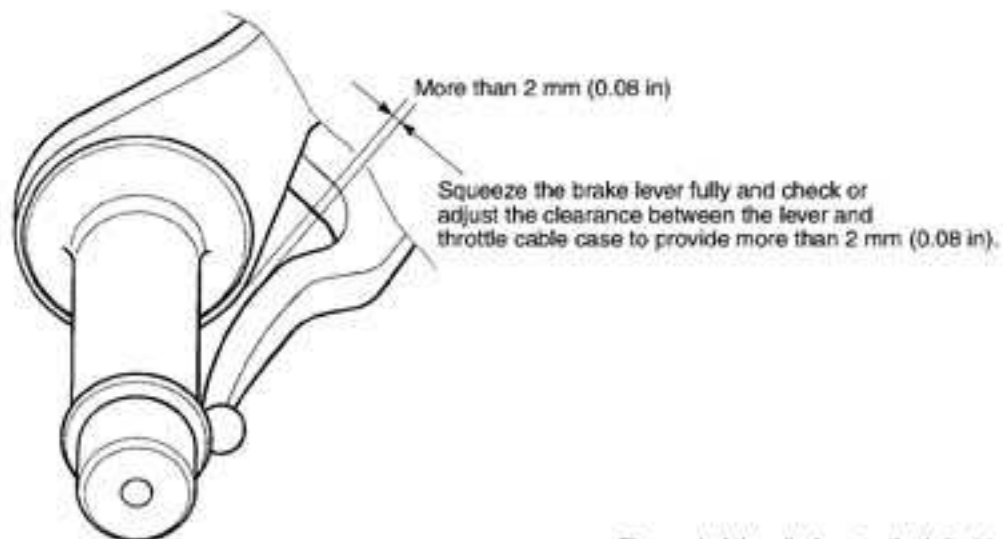

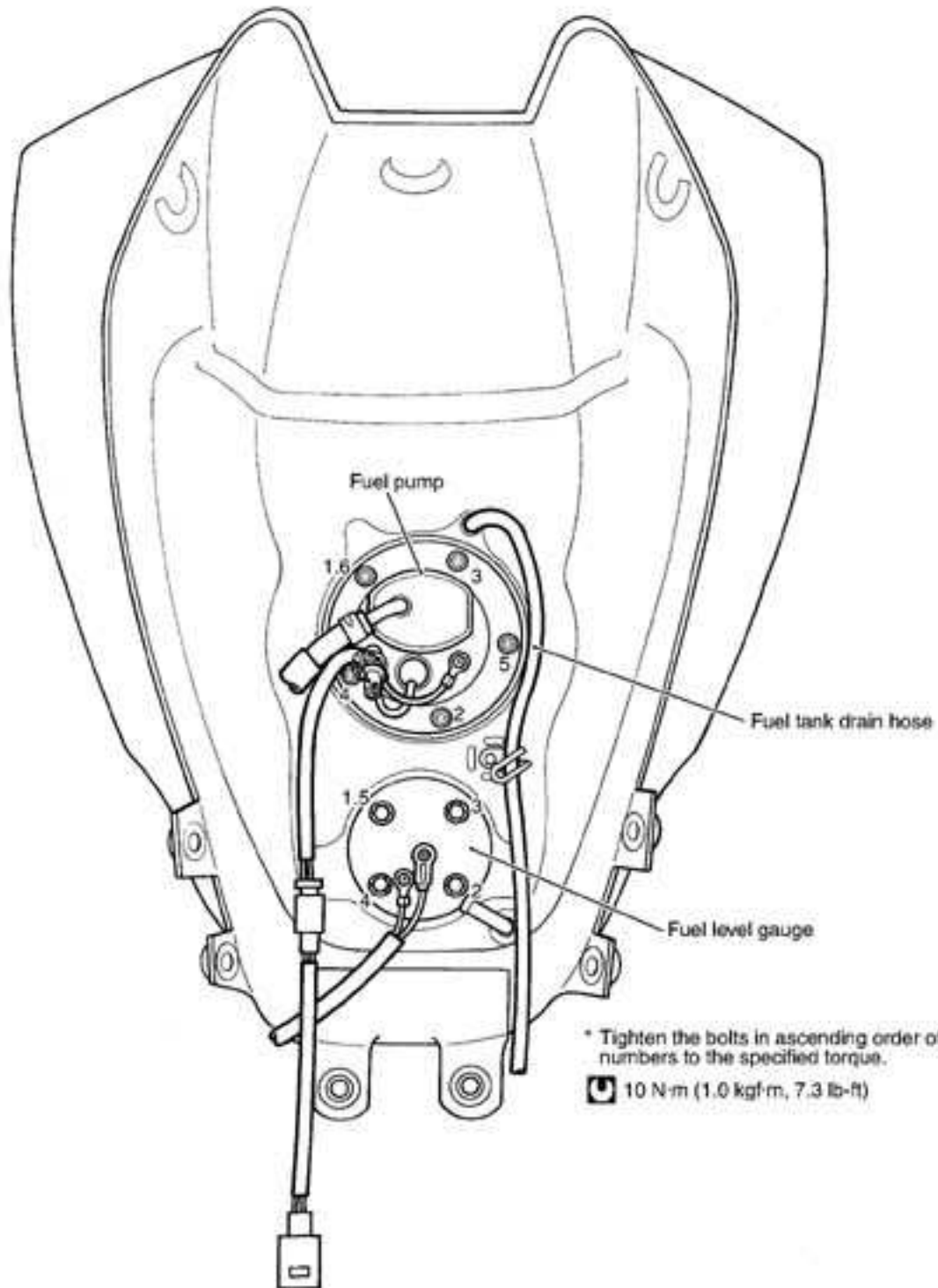
**FUEL PUMP/FUEL LEVEL GAUGE SET-UP**

## FRONT BRAKE HOSE ROUTING

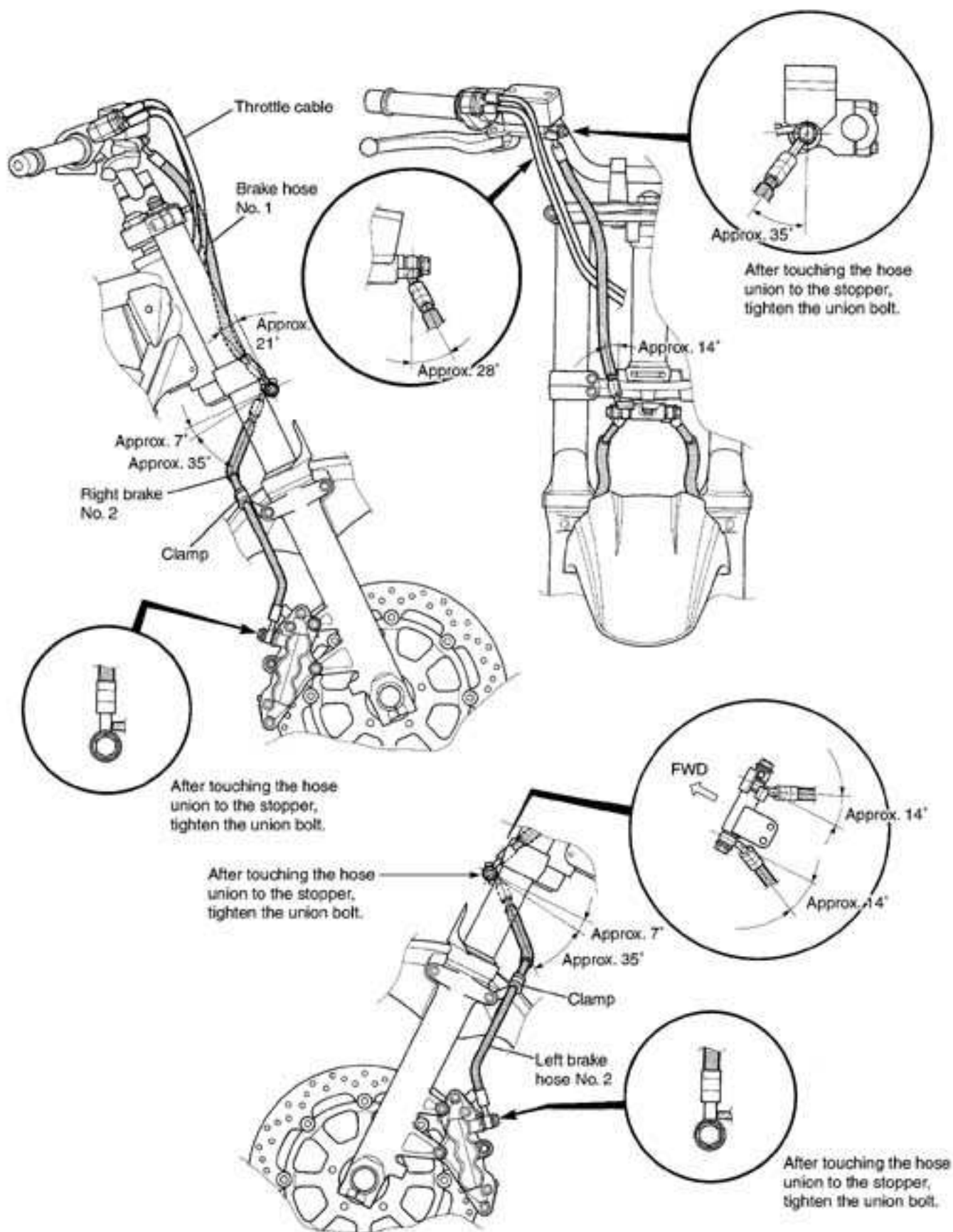

## REAR BRAKE HOSE ROUTING

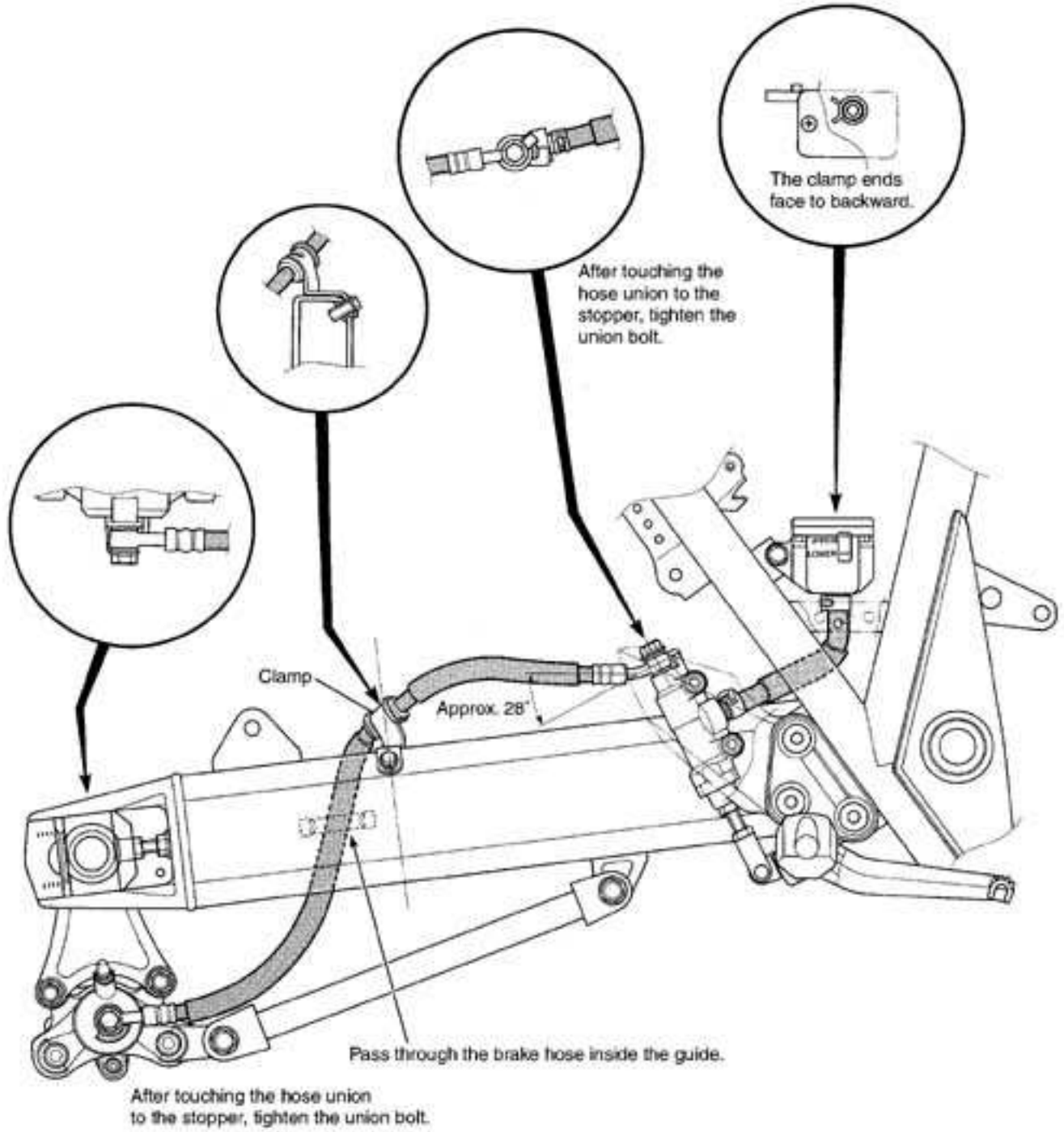



## SIDE-STAND SET-UP

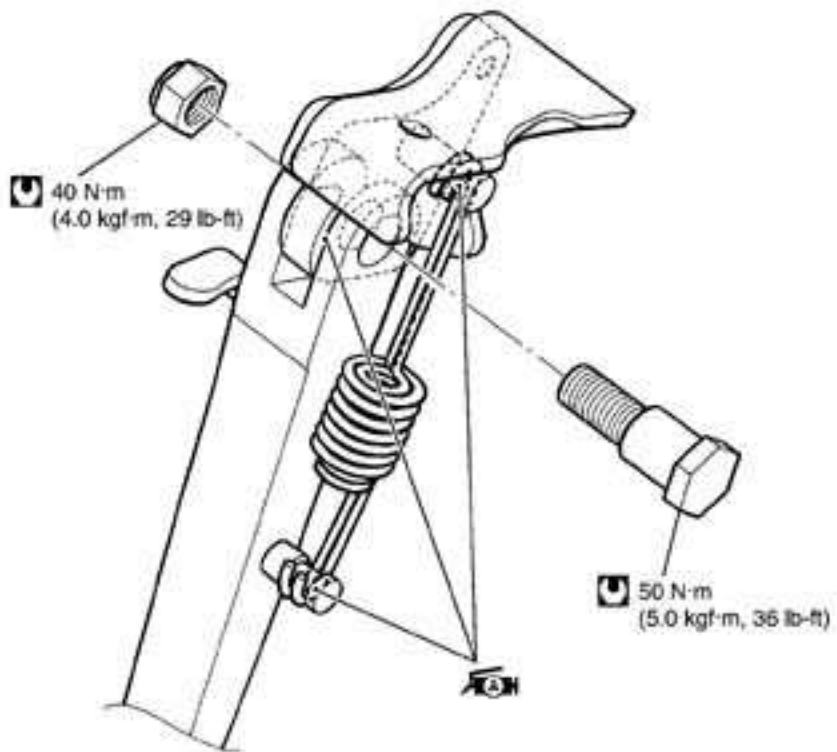

## CENTER STAND SET-UP

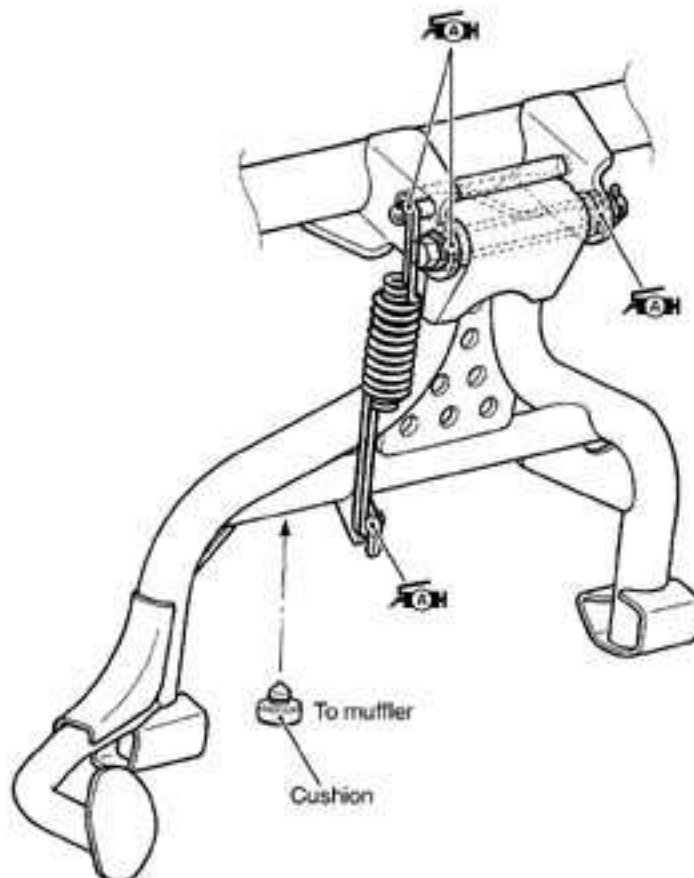

## SEAT LOCK CABLE ROUTING AND LUGGAGE HOOK SET-UP

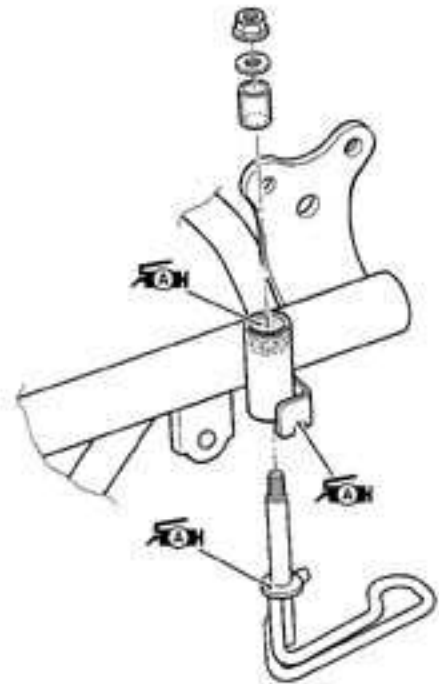
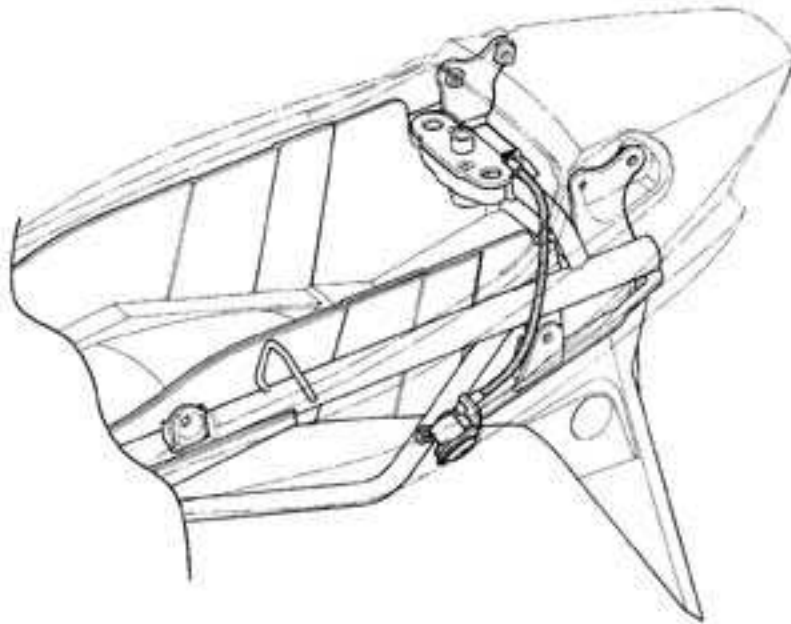

## BRAKE PEDAL SET-UP

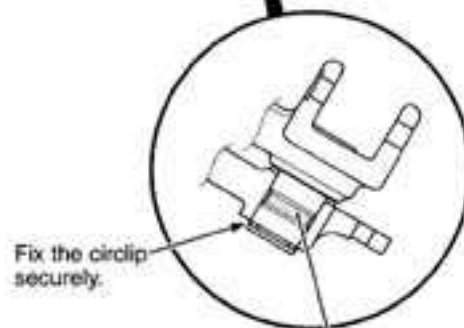
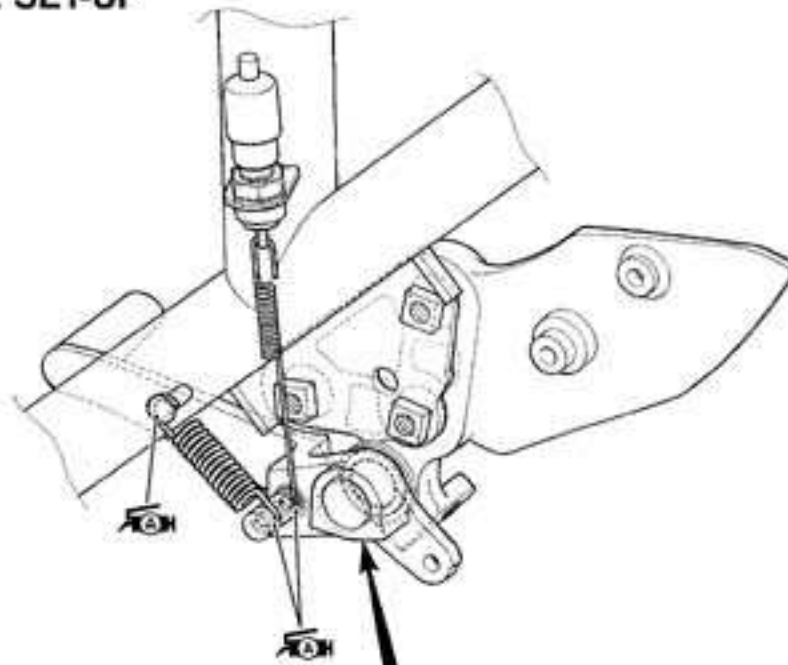

Fix the circlip securely.

Apply grease to the groove.



## FUEL HOSE ROUTING

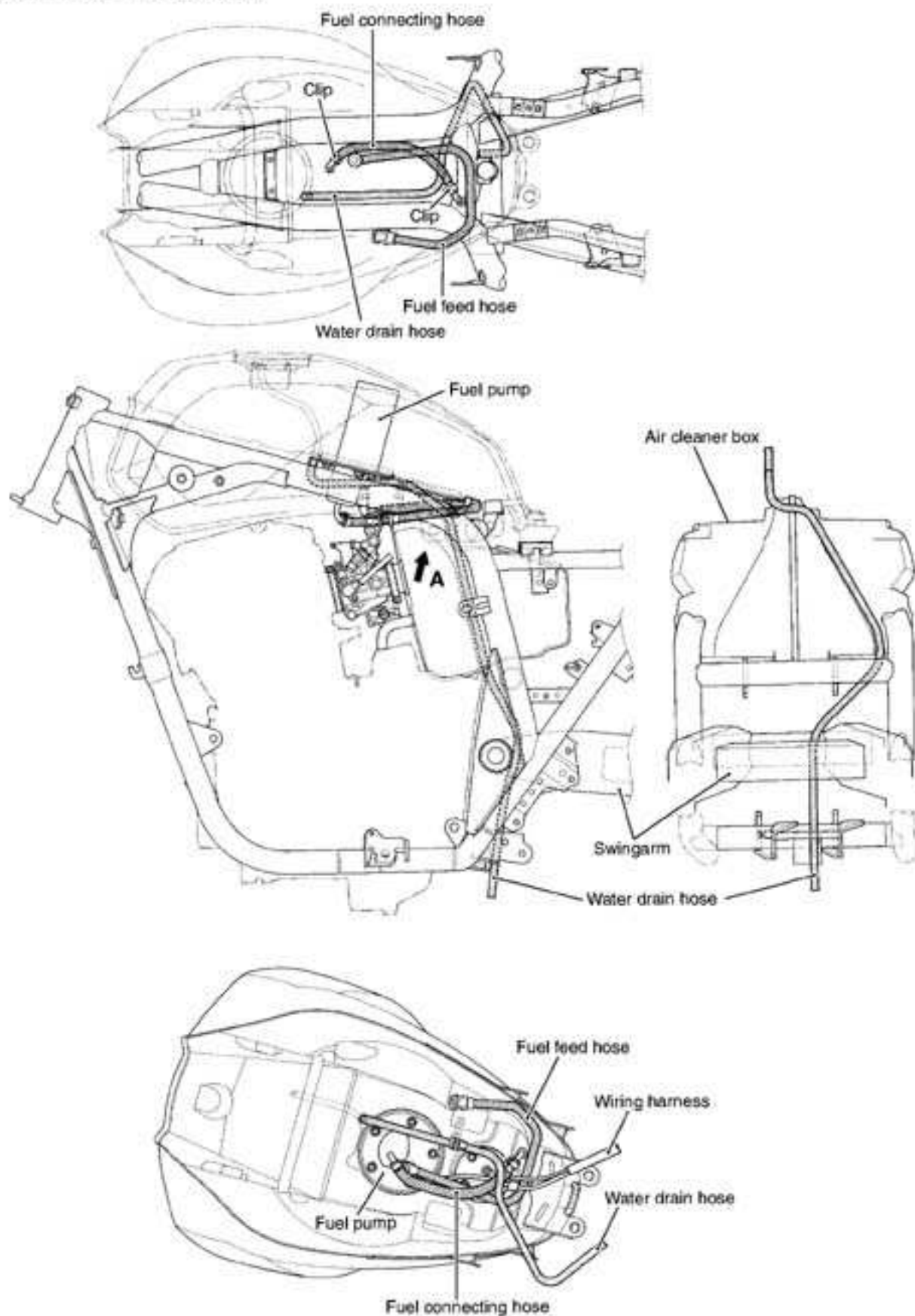

**VIEW OF A**

## FUEL TANK SET-UP

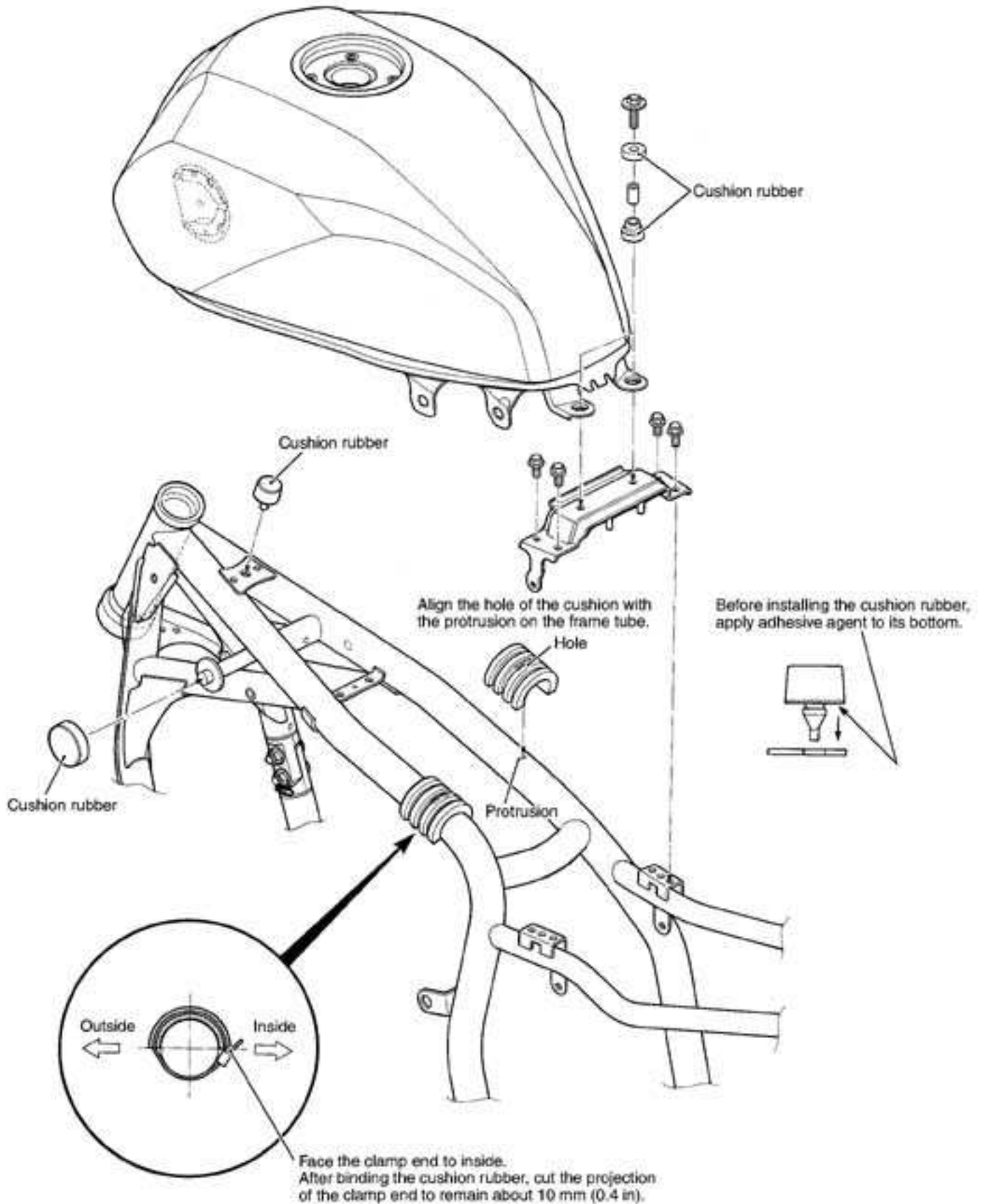

## THROTTLE BODY SET-UP

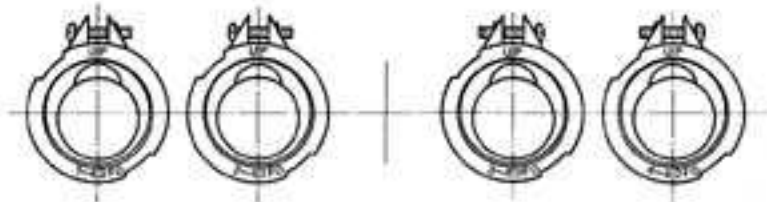

**VIEW OF A**

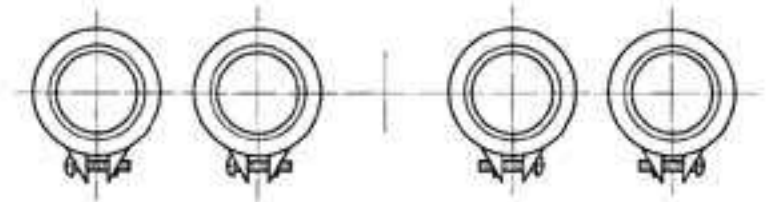

**VIEW OF B**

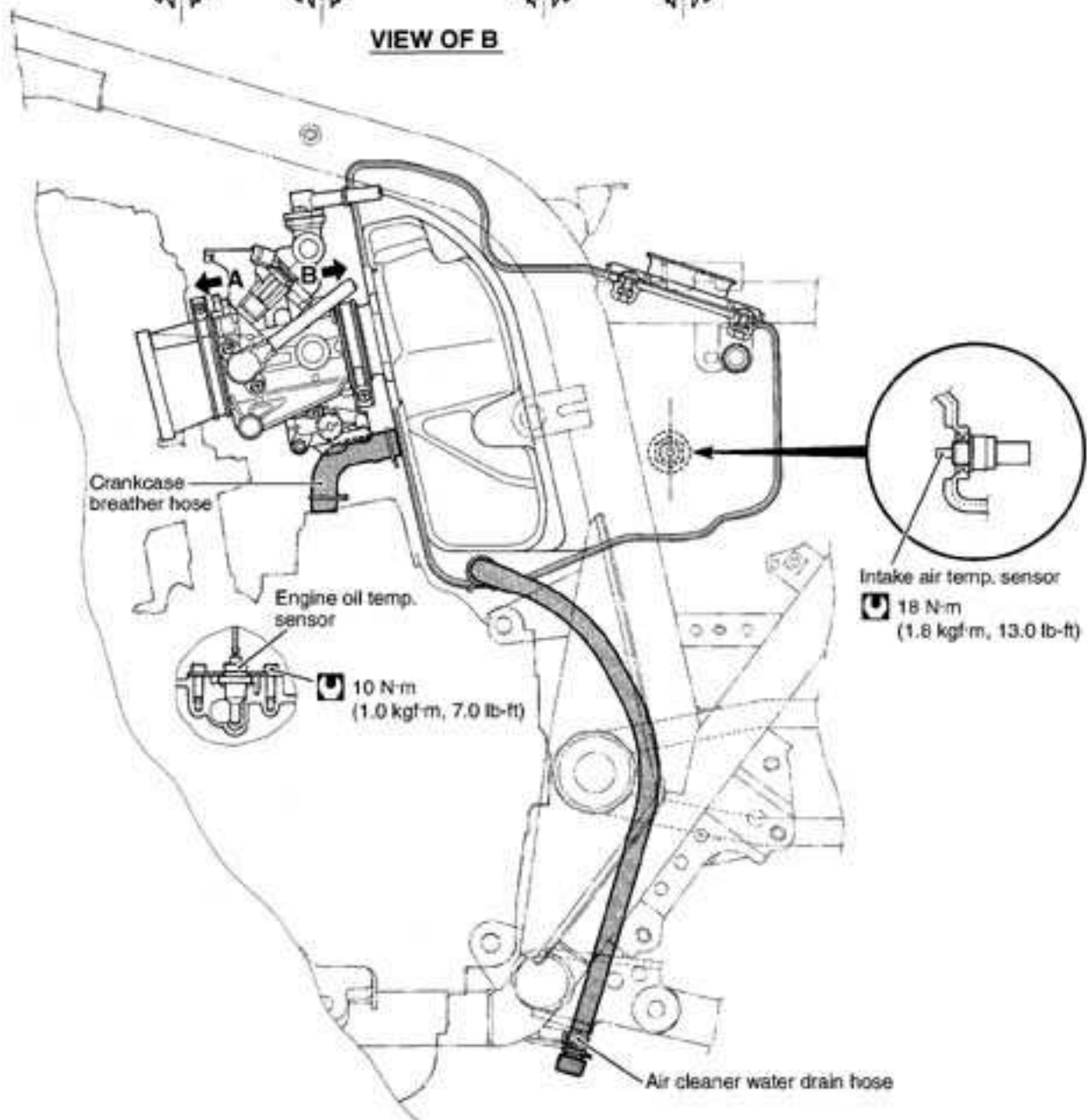



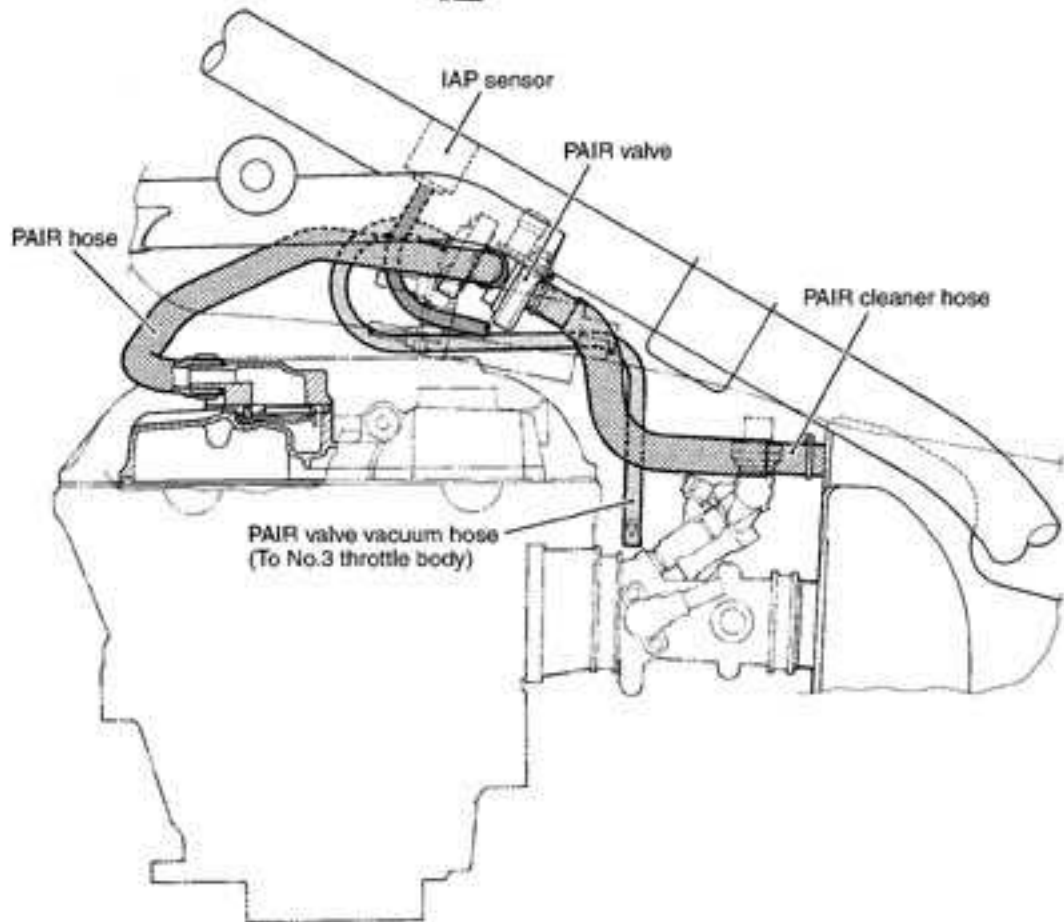
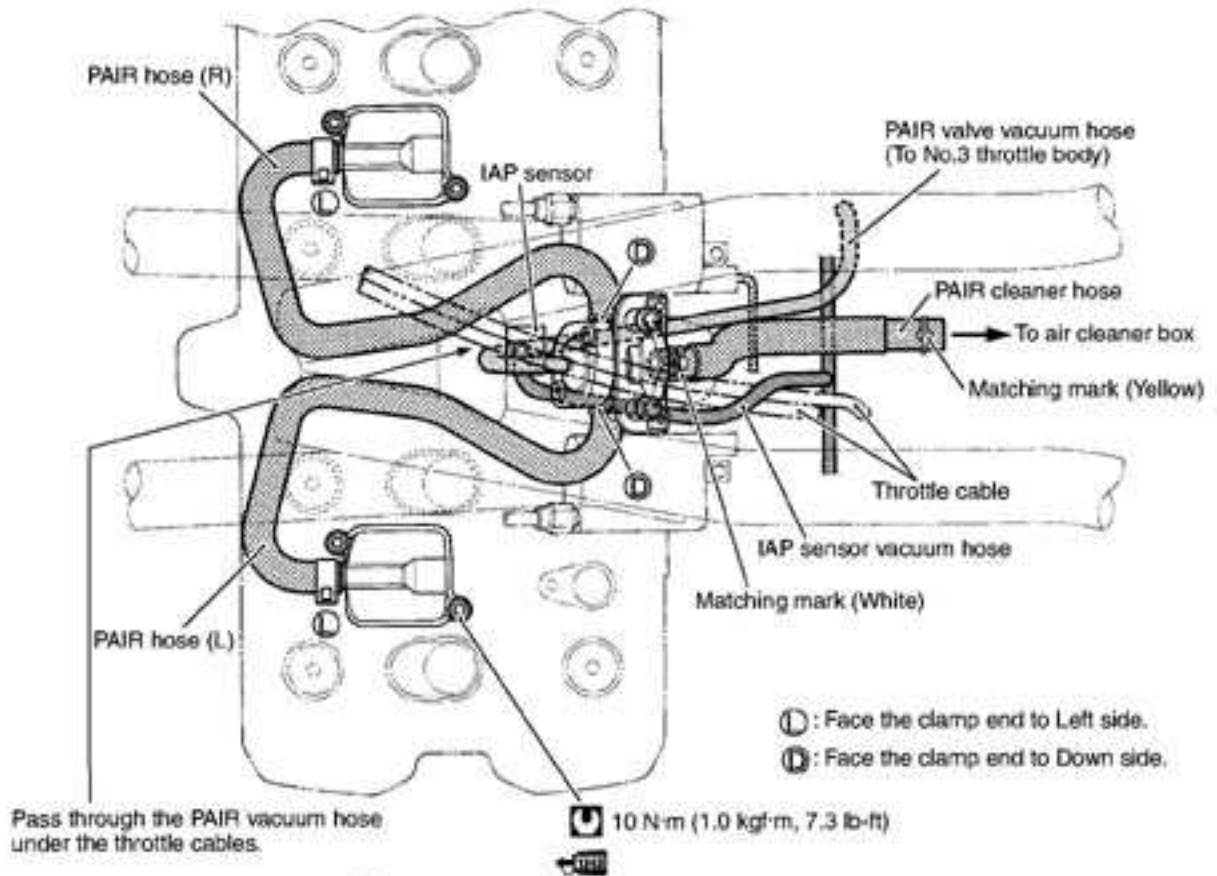















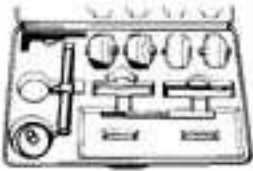





## PAIR (AIR SUPPLY) SYSTEM HOSE ROUTING

















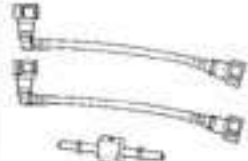

## SPECIAL TOOLS

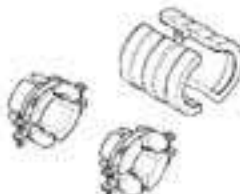
				
09900-06104 Snap ring pliers	09900-06107 Snap ring pliers	09900-06108 Snap ring pliers	09900-18740 Hexagon socket (24 mm)	09900-20101 09900-20102 Vernier calipers
				
09900-20202 Micrometer (25 - 50 mm)	09900-20203 Micrometer (50 - 75 mm)	09900-20204 Micrometer (75 - 100 mm)	09900-20205 Micrometer (0 - 25 mm)	09900-20508 Cylinder gauge set
				
09900-20602 Dial gauge (1/1000 mm, 1 mm)	09900-20605 Dial calipers (1/100 mm, 10 - 34 mm)	09900-20607 Dial gauge (1/100 mm, 10 mm)	09900-20701 Magnetic stand	09900-20803 09900-20806 Thickness gauge
				
09900-20805 Tire depth gauge	09900-21304 V-block (100 mm)	09900-22301 09900-22302 Plastigauge	09900-22401 (10 - 18 mm) 09900-22403 (18 - 35 mm) Small bore gauge	09900-25008 Multi circuit tester set
				
09913-10750 Compression gauge adapter	09913-50121 Oil seal remover	09913-70210 Bearing installer set	09915-40610 Oil filter wrench	09915-64510 Compression gauge



 <p>09915-74520 Oil pressure gauge hose</p>	 <p>09915-74540 Oil pressure gauge adaptor</p>	 <p>09915-77330 Meter (for high pressure)</p>	 <p>09916-10911 Valve lapper set</p>	 <p>09916-14510 Valve spring compressor</p>
 <p>09916-14521 Valve spring compressor attachment</p>	 <p>09916-20610 Valve seat cutter head (N-121)</p>	 <p>09916-20620 Valve seat cutter head (N-122)</p>	 <p>09916-20640 Solid pilot (N-100 -4.5)</p>	 <p>09916-21111 Valve seat cutter set</p>
 <p>09916-33210 Valve guide reamer (4.5 mm)</p>	 <p>09916-34542 Reamer handle</p>	 <p>09916-34561 Valve guide reamer</p>	 <p>09916-43210 Valve guide remover/installer</p>	 <p>09916-74521 Piston ring holder set 09916-74540 Band</p>
 <p>09916-84511 Tweezers</p>	 <p>09917-47010 Vacuum pump gauge</p>	 <p>09920-53740 Clutch sleeve hub holder</p>	 <p>09921-20210 Bearing remover</p>	 <p>09921-20240 Bearing remover set</p>
 <p>09923-73210 Bearing remover</p>	 <p>09923-74510 Bearing remover</p>	 <p>09924-84510 Bearing installer set</p>	 <p>09924-84521 Bearing installer set</p>	 <p>09930-11920 Torx bit JT40H</p>

 <p>09930-11940 Bit holder</p>	 <p>09930-11960 Torx wrench</p>	 <p>09930-30102 Sliding shaft</p>	 <p>09930-30450 Rotor remover</p>	 <p>09930-44530 Generator rotor holder</p>
 <p>09930-82710 Mode selection switch</p>	 <p>09940-14911 Steering stem nut wrench</p>	 <p>09940-30250 Front fork assembling tool</p>	 <p>09940-40211 Fuel pressure gauge adaptor</p>	 <p>09940-40220 Fuel pressure gauge hose attachment</p>
 <p>09940-52841 Front fork inner rod holder</p>	 <p>09940-52861 Front fork oil seal installer</p>	 <p>09940-92720 Spring scale</p>	 <p>09941-34513 Steering race installer</p>	 <p>09941-54911 Bearing outer race remover</p>
 <p>09941-74911 Bearing installer</p>	 <p>09943-74111 Fork oil level gauge</p>	 <p>09944-60210 Wheel bearing remover</p>		

**NOTE:**

When order the special tool, please confirm whether it is available or not.

**TIGHTENING TORQUE****ENGINE**

ITEM	N·m	kgf·m	lb·ft
Exhaust pipe bolt	23	2.3	16.5
Exhaust pipe connecting bolt	20	2.0	14.5
Muffler connecting bolt	24	2.4	17.5
Muffler mounting bolt	23	2.3	16.5
Speed sensor rotor bolt	20	2.0	14.5
Engine sprocket nut	115	11.5	83.0
Cylinder head cover bolt	(M:8)	20	14.5
	(M:7)	14	10.0
Spark plug	11	1.1	8.0
Cam chain guide bolt	10	1.0	7.3
Camshaft journal holder bolt	10	1.0	7.3
Cam chain tension adjuster cap bolt	35	3.5	25.5
Cam chain tension adjuster mounting bolt	10	1.0	7.3
Cylinder head bolt/nut	(M:10) (Initial)	25	18.0
	(Final)	37	27.0
	(M:6)	10	7.3
PAIR reed valve cover bolt	10	1.0	7.3
Clutch cover bolt	11	1.1	8.0
Clutch sleeve hub nut	90	9.0	65.0
Clutch spring set bolt	10	1.0	7.3
Starter clutch bolt	25	2.5	18.0
Generator cover bolt	11	1.1	8.0
Generator rotor bolt	160	16.0	115.5
Generator stator set bolt	10	1.0	7.3
Gearshift cam stopper bolt	10	1.0	7.3
Gearshift cam stopper plate bolt	10	1.0	7.3
Oil pressure switch	14	1.4	10.0
Crankcase bolt	(M:6)	11	8.0
	(M:8)	26	19.0
	(M:9) (Initial)	18	13.0
	(Final)	32	23.0
Oil drain plug	23	2.3	16.5
Cylinder nut	10	1.0	7.3
Cam sprocket bolt	25	2.5	18.0
Oil hose union bolt	(Crankcase - Cylinder head cover)	10	7.3
	(Crankcase - Cylinder head)	20	14.5
CKP sensor rotor bolt	25	2.5	18.0
CKP sensor cover bolt	11	1.1	8.0
Oil gallery plug	(Cylinder head cover)	14	10.0
	(Cylinder head)	20	14.5
	(Main gallery)	35	25.5
	(Sub-gallery)	21	15.0
Oil check valve plug	35	3.5	25.5
Oil pipe bolt	10	1.0	7.3

ITEM	N·m	kgf·m	lb·ft
Balancer lever bolt	10	1.0	7.3
Balancer cover bolt	10	1.0	7.3
Piston cooling oil jet bolt	10	1.0	7.3
Oil pump mounting bolt	10	1.0	7.3
Conrod bearing cap bolt	(Initial)	21	2.1
	(Final)	90° (¼ turn)	
Bearing retainer screw	10	1.0	7.3
Breather cover bolt	10	1.0	7.3
Oil strainer bolt	10	1.0	7.3
Oil pan bolt	11	1.1	8.0
Oil cooler mounting bolt	10	1.0	7.3
Oil cooler hose union bolt	10	1.0	7.3

## FI SYSTEM

ITEM	N·m	kgf·m	lb·ft
Camshaft position sensor mounting bolt	8	0.8	5.7
Intake air temperature sensor	18	1.8	13.0
Fuel delivery pipe mounting screw	5.0	0.5	3.7
Fuel pump mounting bolt	10	1.0	7.3
Throttle body connecting bolt	5.0	0.5	3.7
Actuator motor cover nut	2.0	0.2	1.5
TPS and STPS mounting screw	3.5	0.35	2.5

**CHASSIS**

ITEM	N-m	kgf-m	lb-ft
Steering stem head nut	65	6.5	47.0
Steering stem nut	45	4.5	32.5
Front fork upper clamp bolt	23	2.3	16.5
Front fork lower clamp bolt	23	2.3	16.5
Front fork cap bolt	23	2.3	16.5
Front fork inner rod lock nut	15	1.5	11.0
Front fork damper rod bolt	40	4.0	29.0
Front axle	100	10.0	72.5
Front axle pinch bolt	23	2.3	16.5
Handlebar holder nut	45	4.5	32.5
Handlebar clamp bolt	23	2.3	16.5
Front brake master cylinder mounting bolt	10	1.0	7.3
Front brake caliper mounting bolt	25	2.5	18.0
Front brake caliper housing bolt	21	2.1	15.0
Front brake pad mounting pin	16	1.6	11.5
Brake hose union bolt	23	2.3	16.5
Clutch master cylinder mounting bolt	10	1.0	7.3
Air bleeder valve	8.0	0.8	5.7
Brake disc bolt (Front)	23	2.3	16.5
Brake disc bolt (Rear)	23	2.3	16.5
Rear brake caliper mounting bolt	26	2.6	19.0
Rear brake caliper housing bolt	37	3.7	27.0
Rear brake pad mounting pin	17	1.7	12.5
Rear brake master cylinder mounting bolt	10	1.0	7.3
Rear brake master cylinder rod lock nut	18	1.8	13.0
Front footrest mounting bolt	26	2.6	19.0
Swingarm pivot nut	120	12.0	87.0
Torque link nut (Front)	28	2.8	20.5
Torque link nut (Rear)	34	3.4	24.5
Rear shock absorber mounting bolt (Upper)	23	2.3	16.5
Rear shock absorber mounting bolt/nut (Lower)	34	3.4	24.5
Rear axle nut	100	10.0	72.5
Rear sprocket nut	102	10.2	74.0

## TIGHTENING TORQUE CHART

For other bolts and nuts listed previously, refer to this chart:

Bolt Diameter Ⓐ (mm)	Conventional or "4" marked bolt			"7" marked bolt		
	N·m	kgf·m	lb-ft	N·m	kgf·m	lb-ft
4	1.5	0.15	1.0	2.3	0.23	1.5
5	3	0.3	2.0	4.5	0.45	3.0
6	5.5	0.55	4.0	10	1.0	7.0
8	13	1.3	9.5	23	2.3	16.5
10	29	2.9	21.0	50	5.0	36.0
12	45	4.5	32.5	85	8.5	61.5
14	65	6.5	47.0	135	13.5	97.5
16	105	10.5	76.0	210	21.0	152.0
18	160	16.0	115.5	240	24.0	173.5



Conventional bolt

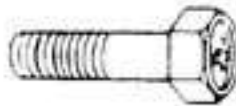

"4" marked bolt

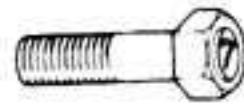

"7" marked bolt

## SERVICE DATA

### VALVE + GUIDE

Unit: mm (in)

ITEM	STD/SPEC.		LIMIT
Valve diam.	IN.	28.5 (1.12)	—
	EX.	25 (0.98)	—
Valve clearance (when cold)	IN.	0.10 – 0.20 (0.004 – 0.008)	—
	EX.	0.20 – 0.30 (0.008 – 0.012)	—
Valve guide to valve stem clearance	IN.	0.010 – 0.037 (0.0004 – 0.0015)	—
	EX.	0.030 – 0.057 (0.0012 – 0.0022)	—
Valve guide I.D.	IN. & EX.	4.500 – 4.512 (0.1772 – 0.1776)	—
Valve stem O.D.	IN.	4.475 – 4.490 (0.1762 – 0.1768)	—
	EX.	4.455 – 4.470 (0.1754 – 0.1760)	—
Valve stem deflection	IN. & EX.	—	0.35 (0.014)
Valve stem runout	IN. & EX.	—	0.05 (0.002)
Valve head thickness	IN. & EX.	—	0.5 (0.02)
Valve seat width	IN. & EX.	0.9 – 1.1 (0.035 – 0.043)	—
Valve head radial runout	IN. & EX.	—	0.03 (0.001)
Valve spring free length	IN. & EX.	INNER	— 38.6 (1.52)
		OUTER	— 40.6 (1.60)
Valve spring tension	IN. & EX.	INNER	4.9 – 5.9 kgf (10.8 – 13.0 lbs) at length 29.9 mm (1.18 in)
		OUTER	13.6 – 15.6 kgf (30.0 – 34.4 lbs) at length 33.4 mm (1.31 in)

## CAMSHAFT + CYLINDER HEAD

Unit: mm (in)

ITEM	STD/SPEC.		LIMIT
Cam height	IN.	35.28 – 35.33 (1.389 – 1.391)	34.98 (1.377)
	EX.	34.18 – 34.22 (1.346 – 1.347)	33.88 (1.334)
Camshaft journal oil clearance	IN. & EX.	0.032 – 0.066 (0.0013 – 0.0026)	0.150 (0.0059)
Camshaft journal holder I.D.	IN. & EX.	24.012 – 24.025 (0.9454 – 0.9459)	—



ITEM	STD/SPEC.		LIMIT
Camshaft journal O.D.	IN. & EX.	23.959 – 23.980 (0.9433 – 0.9441)	—
Camshaft runout	—		0.10 (0.004)
Cam chain pin (at arrow "3")	24th pin		—
Cylinder head distortion	—		0.20 (0.008)

**CYLINDER + PISTON + PISTON RING**

Unit: mm (in)

ITEM	STD/SPEC.			LIMIT
Compression pressure	1 180 kPa (11.8 kgf/cm <sup>2</sup> ) 168 psi			880 kPa (8.8 kgf/cm <sup>2</sup> ) 125 psi
Compression pressure difference	—			200 kPa (2 kgf/cm <sup>2</sup> ) 28 psi
Piston to cylinder clearance	0.015 – 0.025 (0.0006 – 0.0010)			0.120 (0.0047)
Cylinder bore	81.000 – 81.015 (3.1890 – 3.1896)			Nicks or Scratches
Piston diam.	80.980 – 80.995 (3.1881 – 3.1888) Measure at 15 mm (0.6 in) from the skirt end.			80.880 (3.1842)
Cylinder distortion	—			0.20 (0.008)
Piston ring free end gap	1st	N	Approx. 9.5 (0.37)	7.6 (0.30)
	2nd	2N	Approx. 11.0 (0.43)	8.8 (0.35)
Piston ring end gap	1st	N	0.08 – 0.20 (0.003 – 0.008)	0.50 (0.020)
	2nd	2N	0.18 – 0.30 (0.007 – 0.012)	0.50 (0.020)
Piston ring to groove clearance	1st	—		0.180 (0.0071)
	2nd	—		0.150 (0.0059)
Piston ring groove width	1st	1.21 – 1.23 (0.0476 – 0.0484)		—
	2nd	1.01 – 1.03 (0.0398 – 0.0406)		—
	Oil	2.01 – 2.03 (0.0791 – 0.0799)		—
Piston ring thickness	1st	1.175 – 1.190 (0.0463 – 0.0469)		—
	2nd	0.970 – 0.990 (0.0382 – 0.0390)		—
Piston pin bore	18.002 – 18.008 (0.7087 – 0.7090)			18.030 (0.7098)
Piston pin O.D.	17.996 – 18.000 (0.7085 – 0.7087)			17.980 (0.7079)

**CONROD + CRANKSHAFT**

Unit: mm (in)

ITEM	STD/SPEC.		LIMIT
Conrod small end I.D.	18.010 – 18.018 (0.7091 – 0.7094)		18.040 (0.7102)
Conrod big end side clearance	0.10 – 0.20 (0.004 – 0.008)		0.30 (0.012)
Conrod big end width	20.950 – 21.000 (0.8248 – 0.8268)		—
Crank pin width	21.100 – 21.150 (0.8307 – 0.8327)		—
Conrod big end oil clearance	0.032 – 0.056 (0.0013 – 0.0022)		0.080 (0.0031)
Crank pin O.D.	37.976 – 38.000 (1.4951 – 1.4961)		—
Crankshaft journal oil clearance	0.016 – 0.040 (0.0006 – 0.0016)		0.080 (0.0031)
Crankshaft journal O.D.	39.976 – 40.000 (1.5734 – 1.5748)		—
Crankshaft thrust bearing thickness	Right side	2.425 – 2.450 (0.0955 – 0.0965)	—
	Left side	2.430 – 2.585 (0.0957 – 0.1018)	—
Crankshaft thrust clearance	0.055 – 0.110 (0.0022 – 0.0043)		—
Crankshaft runout	—		0.05 (0.002)

**OIL PUMP**

ITEM	STD/SPEC.	LIMIT
Oil pressure (at 60°C, 140°F)	300 – 600 kPa (3.0 – 6.0 kgf/cm <sup>2</sup> , 43 – 85 psi) at 3 000 r/min.	—

**CLUTCH**

Unit: mm (in)

ITEM	STD/SPEC.		LIMIT
Drive plate thickness	No. 1, 2 and 3	3.22 – 3.38 (0.127 – 0.133)	2.92 (0.115)
Drive plate claw width	No. 1, 2 and 3	13.7 – 13.8 (0.5394 – 0.5433)	12.9 (0.5079)
Driven plate distortion	—		0.10 (0.004)
Clutch spring free length	28.96 (1.140)		27.6 (1.087)
Clutch master cylinder bore	14.000 – 14.043 (0.5512 – 0.5529)		—
Clutch master cylinder piston diam.	13.957 – 13.984 (0.5495 – 0.5506)		—
Clutch release cylinder bore	35.700 – 35.762 (1.4055 – 1.4079)		—
Clutch release cylinder piston diam.	35.650 – 35.675 (1.4035 – 1.4045)		—
Clutch fluid type	Brake fluid DOT 4		—

**TRANSMISSION + DRIVE CHAIN**

Unit: mm (in) Except ratio

ITEM		STD/SPEC.	LIMIT
Primary reduction ratio		1.509 (83/55)	—
Final reduction ratio		2.277 (41/18)	—
Gear ratios	Low	2.916 (35/12)	—
	2nd	1.937 (31/16)	—
	3rd	1.526 (29/19)	—
	4th	1.285 (27/21)	—
	5th	1.136 (25/22)	—
	Top	1.000 (24/24)	—
Shift fork to groove clearance		0.10 – 0.30 (0.004 – 0.012)	0.50 (0.020)
Shift fork groove width		5.0 – 5.1 (0.197 – 0.201)	—
Shift fork thickness		4.8 – 4.9 (0.189 – 0.193)	—
Drive chain	Type	RKGB50GSVZ3	—
	Links	116 links	—
	20-pitch length	—	319.4 (12.57)
Drive chain slack (on side-stand)		20 – 30 (0.79 – 1.18)	—
Gearshift lever height		30 – 40 (1.2 – 1.6)	—

**INJECTOR + FUEL PUMP + FUEL PRESSURE REGULATOR**

ITEM	STD/SPEC.	NOTE
Injector resistance	12 – 18 $\Omega$ at 20°C (68°F)	
Fuel pump discharge amount	Approx. 1.2 L (1.3/1.1 US/imp qt) /30 sec.	
Fuel pressure regulator operating set pressure	Approx. 300 kPa (3.0 kgf/cm <sup>2</sup> , 43 psi)	

**FI SENSORS + SECONDARY THROTTLE VALVE ACTUATOR**

ITEM	STD/SPEC.		NOTE
CMP sensor output voltage	More than 3.7 V		
CKP sensor resistance	134 – 202 $\Omega$		
CKP sensor peak voltage	More than 2.7 V		
IAP sensor input voltage	4.5 – 5.5 V		
IAP sensor output voltage	Approx. 2.5 V at idle speed		
TP sensor input voltage	4.5 – 5.5 V		
TP sensor resistance	Closed	Approx. 1.1 k $\Omega$	
	Opened	Approx. 4.3 k $\Omega$	
TP sensor output voltage	Closed	Approx. 1.1 V	
	Opened	Approx. 4.3 V	
EOT sensor input voltage	4.5 – 5.5 V		
EOT sensor resistance	Approx. 61.3 k $\Omega$ at 20°C (68°F)		W – W
IAT sensor input voltage	4.5 – 5.5 V		
IAT sensor resistance	Approx. 2.6 k $\Omega$ at 20°C (68°F)		Terminal – Terminal
AP sensor input voltage	4.5 – 5.5 V		
AP sensor output voltage	Approx. 4.0 V at 100 kPa (760 mmHg)		
TO sensor resistance	60 – 64 k $\Omega$		
TO sensor voltage	Approx. 3.8 V		
GP switch voltage	More than 0.6 V (From 1st to Top)		
Injector voltage	Battery voltage		
Ignition coil primary peak voltage	More than 150 V (When cranking)		
STP sensor input voltage	4.5 – 5.5 V		
STP sensor resistance	Closed	Approx. 0.8 k $\Omega$	
	Opened	Approx. 3.9 k $\Omega$	
STP sensor output voltage	Closed	Approx. 0.8 V	
	Opened	Approx. 4.0 V	
STV actuator resistance	Approx. 4.8 – 7.2 $\Omega$		

## THROTTLE BODY

ITEM	STD/SPEC.
Bore size	34 mm
I.D. No.	42F0
Idle r/min.	1 100 ± 100 r/min.
Fast idle r/min.	1 500 – 1 700 r/min. (When engine is cold)
Throttle cable play	2.0 – 4.0 mm (0.08 – 0.16 in)

## ELECTRICAL

Unit: mm (in)

ITEM		STD/SPEC.	NOTE
Firing order		1-2-4-3	
Spark plug	Type	NGK: CR8EK DENSO: U24ETR	
	Gap	0.6 – 0.7 (0.024 – 0.028)	
Spark performance		Over 8 (0.3) at 1 atm.	
CKP sensor resistance		134 – 202 Ω	
CKP sensor peak voltage		More than 2.7 V	⊕: Y ⊖: Bl
Ignition coil resistance	Primary	2 – 4 Ω	Terminal – Terminal
	Secondary	25 – 40 kΩ	Plug cap – Plug cap
Ignition coil primary peak voltage		More than 150 V	No.1&4 ⊕: W/Bl ⊖: O/W No.2&3 ⊕: B ⊖: O/W
Generator coil resistance		0.2 – 1.0 Ω	
Generator no-load voltage (when engine is cold)		More than 60 V (AC) at 5 000 r/min.	
Regulated voltage		14.0 – 15.5 V at 5 000 r/min.	
Starter relay resistance		3 – 5 Ω	
GP switch voltage		More than 0.6 V (From 1st to top without neutral)	
Battery	Type designation	FTX14-BS	
	Capacity	12 V 43.2 kC (12 Ah)/10 HR	
Fuse size	Headlight	HI	10 A
		LO	10 A
	Signal	15 A	
	Ignition	15 A	
	Meter	10 A	
	Fan	10 A	
	Main	30 A	

**WATTAGE**

ITEM		STD/SPEC.
Headlight	HI	60 W
	LO	55 W
Parking or position light		5 W (Except for E-24)
Brake light/Taillight		21/5 W × 2
Turn signal light		21 W × 4
Speedometer light		LED
Tachometer light		LED
Turn signal indicator light		LED
High beam indicator light		LED
Neutral indicator light		LED
FI indicator light		LED
Oil pressure indicator light		LED

**BRAKE + WHEEL**

Unit: mm (in)

ITEM	STD/SPEC.		LIMIT
Rear brake pedal height	35 – 45 (1.4 – 1.8)		—
Brake disc thickness	Front	4.8 – 5.2 (0.189 – 0.205)	4.5 (0.177)
	Rear	5.3 – 5.7 (0.209 – 0.224)	5.0 (0.197)
Brake disc runout	—		0.30 (0.012)
Master cylinder bore	Front	15.870 – 15.913 (0.6248 – 0.6265)	—
	Rear	12.700 – 12.743 (0.5000 – 0.5017)	—
Master cylinder piston diam.	Front	15.827 – 15.854 (0.6231 – 0.6242)	—
	Rear	12.657 – 12.684 (0.4983 – 0.4994)	—
Brake caliper cylinder bore	Front	Leading	24.000 – 24.076 (0.9449 – 0.9479)
		Trailing	27.000 – 27.076 (1.0630 – 1.0660)
	Rear	38.180 – 38.230 (1.5031 – 1.5051)	
Brake caliper piston diam.	Front	Leading	23.925 – 23.975 (0.9419 – 0.9439)
		Trailing	26.920 – 26.970 (1.0598 – 1.0618)
	Rear	38.115 – 38.148 (1.5006 – 1.5019)	
Brake fluid type	DOT 4		—

ITEM	STD/SPEC.		LIMIT
Wheel rim runout	Axial	—	2.0 (0.08)
	Radial	—	2.0 (0.08)
Wheel rim size	Front	17 × MT 3.50, 17 M/C × MT 3.50	—
	Rear	17 × MT 6.00, 17 M/C × MT 6.00	—
Wheel axle runout	Front	—	0.25 (0.010)
	Rear	—	0.25 (0.010)

**TIRE**

Unit: mm (in)

ITEM	STD/SPEC.		LIMIT
Cold inflation tire pressure (Solo riding)	Front	250 kPa (2.50 kgf/cm <sup>2</sup> , 36 psi)	—
	Rear	250 kPa (2.50 kgf/cm <sup>2</sup> , 36 psi)	—
Cold inflation tire pressure (Dual riding)	Front	250 kPa (2.50 kgf/cm <sup>2</sup> , 36 psi)	—
	Rear	290 kPa (2.90 kgf/cm <sup>2</sup> , 42 psi)	—
Tire size	Front	120/70 ZR17 (58W), 120/70ZR17M/C (58 W)	—
	Rear	190/50 ZR17 (73W), 190/50ZR17M/C (73 W)	—
Tire type	Front	BRIDGESTONE: BT020F F	—
	Rear	BRIDGESTONE: BT020R	—
Tire tread depth (Recommended depth)	Front	—	1.6 (0.06)
	Rear	—	2.0 (0.08)

**SUSPENSION**

Unit: mm (in)

ITEM	STD/SPEC.		LIMIT
Front fork stroke	130 (5.12)		—
Front fork spring free length	322.6 (12.70)		316 (12.44)
Front fork oil level (without spring, outer tube fully compressed)	108 (4.25)		—
Front fork oil type	SUZUKI FORK OIL L01 or an equivalent fork oil		—
Front fork oil capacity (each leg)	644 ml (21.76/22.68 US/Imp oz)		—
Front fork spring adjuster	5th groove from top		—
Front fork damping force adjuster	Rebound	8 clicks out from stiffest position	—
	Compression	7 clicks out from stiffest position	—
Rear shock absorber spring adjuster	1.5		—
Rear shock absorber damping force adjuster	Rebound	II	—
	Compression	2	—



ITEM	STD/SPEC.	LIMIT
Rear wheel travel	123 (4.8)	—
Swingarm pivot shaft runout	—	0.3 (0.01)

**FUEL + OIL**

ITEM	STD/SPEC.		NOTE
Fuel type	Gasoline used should be graded 95 octane or higher. An unleaded gasoline is recommended.		
Fuel tank capacity	including reserve	22 L (5.8/4.8 US/imp gal)	
Engine oil type	SAE 10W/40, API, SF or SG		
Engine oil capacity	Change	4 200 ml (4.4/3.7 US/imp qt)	
	Filter change	4 800 ml (5.1/4.2 US/imp qt)	
	Overhaul	5 700 ml (6.0/5.0 US/imp qt)	

Prepared by

**SUZUKI MOTOR CORPORATION**

Overseas Service Department

March, 2001

Part No. 99500-39220-01E

Printed in Japan