

**Z125**  
**Z125 PRO**

---

**Motorcycle**  
**Service Manual**

---



**Kawasaki**



# Quick Reference Guide

<b>General Information</b>	<b>1</b>
<b>Periodic Maintenance</b>	<b>2</b>
<b>Fuel System (DFI)</b>	<b>3</b>
<b>Engine Top End</b>	<b>4</b>
<b>Clutch</b>	<b>5</b>
<b>Engine Lubrication System</b>	<b>6</b>
<b>Engine Removal/Installation</b>	<b>7</b>
<b>Crankshaft/Transmission</b>	<b>8</b>
<b>Wheels/Tires</b>	<b>9</b>
<b>Final Drive</b>	<b>10</b>
<b>Brakes</b>	<b>11</b>
<b>Suspension</b>	<b>12</b>
<b>Steering</b>	<b>13</b>
<b>Frame</b>	<b>14</b>
<b>Electrical System</b>	<b>15</b>
<b>Appendix</b>	<b>16</b>

This quick reference guide will assist you in locating a desired topic or procedure.

- Bend the pages back to match the black tab of the desired chapter number with the black tab on the edge at each table of contents page.
- Refer to the sectional table of contents for the exact pages to locate the specific topic required.





**Z125**  
**Z125 PRO**

# Motorcycle Service Manual

---

All rights reserved. No parts of this publication may be reproduced, stored in a retrieval system, or transmitted in any form or by any means, electronic mechanical photocopying, recording or otherwise, without the prior written permission of Quality Assurance Division/Motorcycle & Engine Company/Kawasaki Heavy Industries, Ltd., Japan.

No liability can be accepted for any inaccuracies or omissions in this publication, although every possible care has been taken to make it as complete and accurate as possible.

The right is reserved to make changes at any time without prior notice and without incurring an obligation to make such changes to products manufactured previously. See your Motorcycle dealer for the latest information on product improvements incorporated after this publication.

All information contained in this publication is based on the latest product information available at the time of publication. Illustrations and photographs in this publication are intended for reference use only and may not depict actual model component parts.

## LIST OF ABBREVIATIONS

A	ampere(s)	JASO	Japanese Automotive Standards Organization
ABDC	after bottom dead center	KDS	Kawasaki diagnostic system
AC	alternating current	km/h	kilometers per hour
Ah	ampere hour	L	liter(s)
API	American Petroleum Institute	lb	pound(s)
ATDC	after top dead center	LCD	liquid crystal display
BBDC	before bottom dead center	LED	light emitting diode
BDC	bottom dead center	m	meter(s)
BTDC	before top dead center	min	minute(s)
°C	degree(s) celsius	mmHg	millimeters of mercury
cmHg	centimeters of mercury	mph	miles per hour
CPU	central processing unit	N	newton(s)
cu in.	cubic inch(es)	oz	ounce(s)
DC	direct current	Pa	pascal(s)
DFI	digital fuel injection	PS	horsepower
DOT	Department of Transportation	psi	pound(s) per square inch
ECU	electronic control unit	qt	quart(s)
F	farad(s)	r	revolution
°F	degree(s) fahrenheit	rpm	revolution(s) per minute
FI	fuel injection	s	second(s)
ft	foot, feet	SAE	Society of Automotive Engineers
g	gram(s)	SOHC	single overhead camshaft
gal	gallon(s)	TDC	top dead center
h	hour(s)	TIR	total indicator reading
HP	horsepower(s)	V	volt(s)
IC	integrated circuit	W	watt(s)
in.	inch(es)	Ω	ohm(s)
ISC	idle speed control		

## COUNTRY AND AREA CODES

AU	Australia	MY	Malaysia
CA	Canada	PH	Philippines
CAL	California (with Evaporative Emission Control System)	TH	Thailand
ID	Indonesia	US	United States

## EMISSION CONTROL INFORMATION

To protect the environment in which we all live, Kawasaki has incorporated crankcase emission (1) and exhaust emission (2) control systems in compliance with applicable regulations of the United States Environmental Protection Agency and California Air Resources Board. Additionally, Kawasaki has incorporated an evaporative emission control system (3) in compliance with applicable regulations of the California Air Resources Board on vehicles sold in California only.

### 1. Crankcase Emission Control System

This system eliminates the release of crankcase vapors into the atmosphere. Instead, the vapors are routed through an oil separator to the intake side of the engine. While the engine is operating, the vapors are drawn into combustion chamber, where they are burned along with the fuel and air supplied by the fuel injection system.

### 2. Exhaust Emission Control System

This system reduces the amount of pollutants discharged into the atmosphere by the exhaust of this motorcycle. The fuel, ignition, and exhaust systems of this motorcycle have been carefully designed and constructed to ensure an efficient engine with low exhaust pollutant levels.

The exhaust system of this model motorcycle manufactured primarily for sale in California includes a catalytic converter system.

### 3. Evaporative Emission Control System

Vapors caused by fuel evaporation in the fuel system are not vented into the atmosphere. Instead, fuel vapors are routed into the running engine to be burned, or stored in a canister when the engine is stopped.

The Clean Air Act, which is the Federal law covering motor vehicle pollution, contains what is commonly referred to as the Act's "tampering provisions."

"Sec. 203(a) The following acts and the causing thereof are prohibited.

(3)(A) for any person to remove or render inoperative any device or element of design installed on or in a motor vehicle or motor vehicle engine in compliance with regulations under this title prior to its sale and delivery to the ultimate purchaser, or for any manufacturer or dealer knowingly to remove or render inoperative any such device or element of design after such sale and delivery to the ultimate purchaser.

(3)(B) for any person engaged in the business of repairing, servicing, selling, leasing, or trading motor vehicles or motor vehicle engines, or who operates a fleet of motor vehicles knowingly to remove or render inoperative any device or element of design installed on or in a motor vehicle or motor vehicle engine in compliance with regulations under this title following its sale and delivery to the ultimate purchaser..."

### NOTE

○ *The phrase "remove or render inoperative any device or element of design" has been generally interpreted as follows.*

1. *Tampering does not include the temporary removal or rendering inoperative of devices or elements of design in order to perform maintenance.*
2. *Tampering could include.*
  - a. *Maladjustment of vehicle components such that the emission standards are exceeded.*
  - b. *Use of replacement parts or accessories which adversely affect the performance or durability of the motorcycle.*
  - c. *Addition of components or accessories that result in the vehicle exceeding the standards.*
  - d. *Permanently removing, disconnecting, or rendering inoperative any component or element of design of the emission control systems.*

**WE RECOMMEND THAT ALL DEALERS OBSERVE THESE PROVISIONS OF FEDERAL LAW, THE VIOLATION OF WHICH IS PUNISHABLE BY CIVIL PENALTIES NOT EXCEEDING \$10 000 PER VIOLATION.**

## **TAMPERING WITH NOISE CONTROL SYSTEM PROHIBITED**

Federal law prohibits the following acts or the causing thereof. (1) The removal or rendering inoperative by any person other than for purposes of maintenance, repair, or replacement, of any device or element of design incorporated into any new vehicle for the purpose of noise control prior to its sale or delivery to the ultimate purchaser or while it is in use, or (2) the use of the vehicle after such device or element of design has been removed or rendered inoperative by any person.

Among those acts presumed to constitute tampering are the acts listed below.

- Replacement of the original exhaust system or muffler with a component not in compliance with Federal regulations.
- Removal of the muffler(s) or any internal portion of the muffler(s).
- Removal of the air box or air box cover.
- Modifications to the muffler(s) or air intake system by cutting, drilling, or other means if such modifications result in increased noise levels.



# Foreword

This manual is designed primarily for use by trained mechanics in a properly equipped shop. However, it contains enough detail and basic information to make it useful to the owner who desires to perform his own basic maintenance and repair work. A basic knowledge of mechanics, the proper use of tools, and workshop procedures must be understood in order to carry out maintenance and repair satisfactorily. Whenever the owner has insufficient experience or doubts his ability to do the work, all adjustments, maintenance, and repair should be carried out only by qualified mechanics.

In order to perform the work efficiently and to avoid costly mistakes, read the text, thoroughly familiarize yourself with the procedures before starting work, and then do the work carefully in a clean area. Whenever special tools or equipment are specified, do not use makeshift tools or equipment. Precision measurements can only be made if the proper instruments are used, and the use of substitute tools may adversely affect safe operation.

**For the duration of the warranty period,** we recommend that all repairs and scheduled maintenance be performed in accordance with this service manual. Any owner maintenance or repair procedure not performed in accordance with this manual may void the warranty.

To get the longest life out of your vehicle.

- Follow the Periodic Maintenance Chart in the Service Manual.
- Be alert for problems and non-scheduled maintenance.
- Use proper tools and genuine Kawasaki Motorcycle parts. Special tools, gauges, and testers that are necessary when servicing Kawasaki motorcycles are introduced by the Service Manual. Genuine parts provided as spare parts are listed in the Parts Catalog.
- Follow the procedures in this manual carefully. Don't take shortcuts.
- Remember to keep complete records of maintenance and repair with dates and any new parts installed.

---

## How to Use This Manual

---

In this manual, the product is divided into its major systems and these systems make up the manual's chapters. The Quick Reference

Guide shows you all of the product's system and assists in locating their chapters. Each chapter in turn has its own comprehensive Table of Contents.

For example, if you want ignition coil information, use the Quick Reference Guide to locate the Electrical System chapter. Then, use the Table of Contents on the first page of the chapter to find the Ignition Coil section.

Whenever you see symbols, heed their instructions! Always follow safe operating and maintenance practices.

### **DANGER**

**DANGER indicates a hazardous situation which, if not avoided, will result in death or serious injury.**

### **WARNING**

**WARNING indicates a hazardous situation which, if not avoided, could result in death or serious injury.**

### **NOTICE**

**NOTICE is used to address practices not related to personal injury.**

This manual contains four more symbols which will help you distinguish different types of information.

### **NOTE**

○*NOTE indicates information that may help or guide you in the operation or service of the vehicle.*

- Indicates a procedural step or work to be done.
- Indicates a procedural sub-step or how to do the work of the procedural step it follows. It also precedes the text of a NOTE.
- ★ Indicates a conditional step or what action to take based on the results of the test or inspection in the procedural step or sub-step it follows.

In most chapters an exploded view illustration of the system components follows the Table of Contents. In these illustrations you will find the instructions indicating which parts require specified tightening torque, oil, grease or a locking agent during assembly.



# General Information

## Table of Contents

Before Servicing .....	1-2
Model Identification.....	1-7
General Specifications.....	1-10
Unit Conversion Table .....	1-13

# 1-2 GENERAL INFORMATION

## Before Servicing

Before starting to perform an inspection service or carry out a disassembly and reassembly operation on a motorcycle, read the precautions given below. To facilitate actual operations, notes, illustrations, photographs, cautions, and detailed descriptions have been included in each chapter wherever necessary. This section explains the items that require particular attention during the removal and reinstallation or disassembly and reassembly of general parts.

Especially note the following.

### **Battery Ground**

Before completing any service on the motorcycle, disconnect the battery cables from the battery to prevent the engine from accidentally turning over. Disconnect the ground cable (-) first and then the positive (+). When completed with the service, first connect the positive (+) cable to the positive (+) terminal of the battery then the negative (-) cable to the negative terminal.

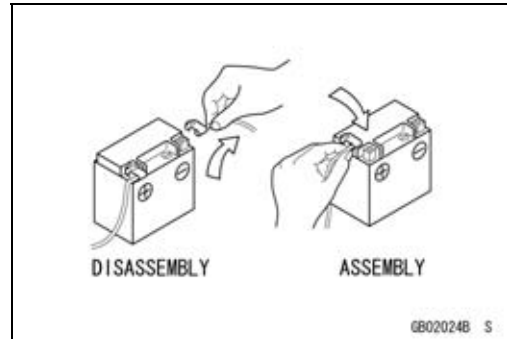

### **Edges of Parts**

Lift large or heavy parts wearing gloves to prevent injury from possible sharp edges on the parts.

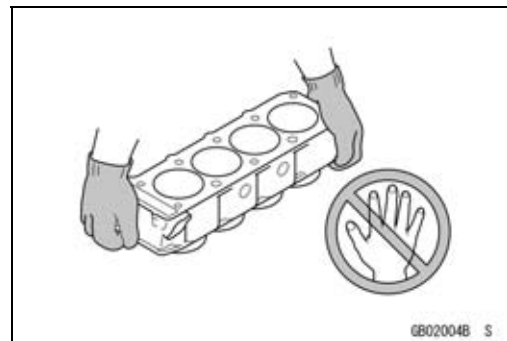

### **Solvent**

Use a high flash-point solvent when cleaning parts. High flash-point solvent should be used according to directions of the solvent manufacturer.

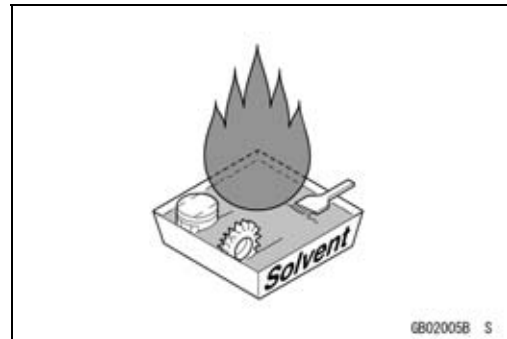

### **Cleaning Vehicle before Disassembly**

Clean the vehicle thoroughly before disassembly. Dirt or other foreign materials entering into sealed areas during vehicle disassembly can cause excessive wear and decrease performance of the vehicle.

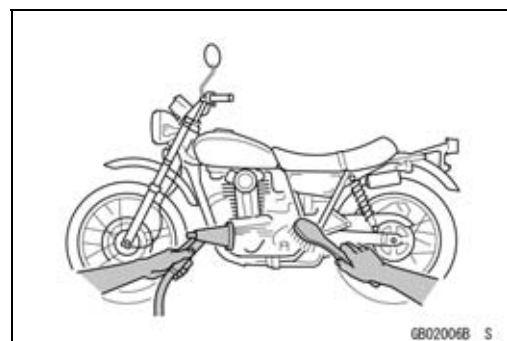

## Before Servicing

### **Arrangement and Cleaning of Removed Parts**

Disassembled parts are easy to confuse. Arrange the parts according to the order the parts were disassembled and clean the parts in order prior to assembly.

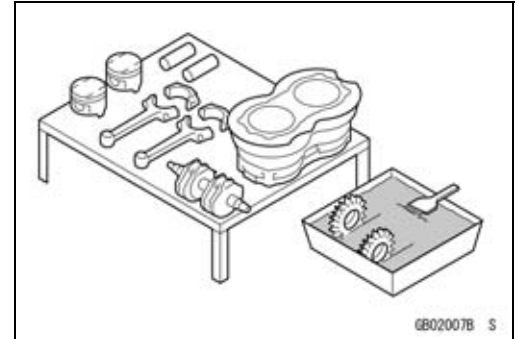

### **Storage of Removed Parts**

After all the parts including subassembly parts have been cleaned, store the parts in a clean area. Put a clean cloth or plastic sheet over the parts to protect from any foreign materials that may collect before re-assembly.

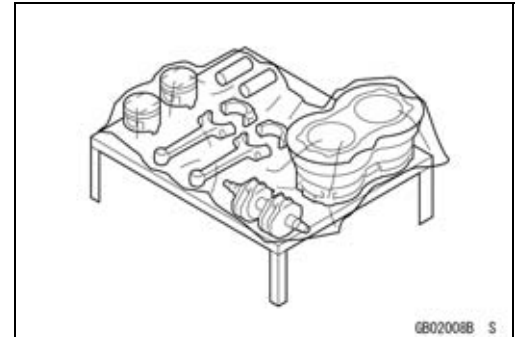

### **Inspection**

Reuse of worn or damaged parts may lead to serious accident. Visually inspect removed parts for corrosion, discoloration, or other damage. Refer to the appropriate sections of this manual for service limits on individual parts. Replace the parts if any damage has been found or if the part is beyond its service limit.

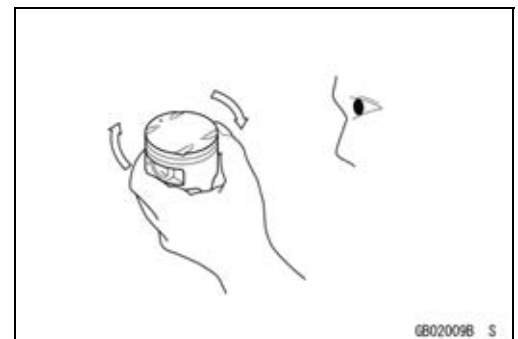

### **Replacement Parts**

Replacement parts must be KAWASAKI genuine or recommended by KAWASAKI. Gaskets, O-rings, oil seals, grease seals, circlips, cotter pins or self-locking nuts must be replaced with new ones whenever disassembled.

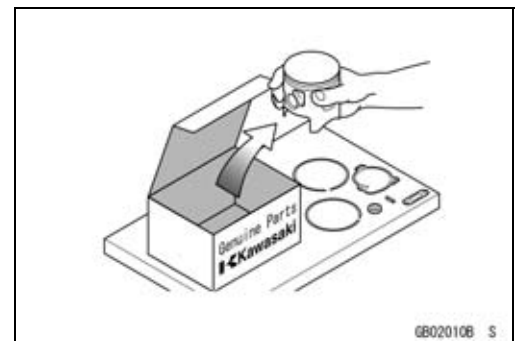

### **Assembly Order**

In most cases assembly order is the reverse of disassembly, however, if assembly order is provided in this Service Manual, follow the procedures given.

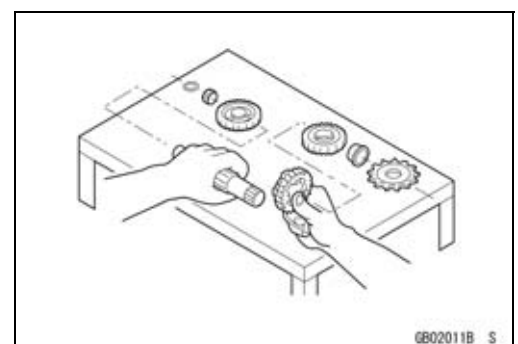

## 1-4 GENERAL INFORMATION

### Before Servicing

#### **Tightening Sequence**

Generally, when installing a part with several bolts, nuts, or screws, start them all in their holes and tighten them to a snug fit. Then tighten them according to the specified sequence to prevent case warpage or deformation which can lead to malfunction. Conversely when loosening the bolts, nuts, or screws, first loosen all of them by about a quarter turn and then remove them. If the specified tightening sequence is not indicated, tighten the fasteners alternating diagonally.

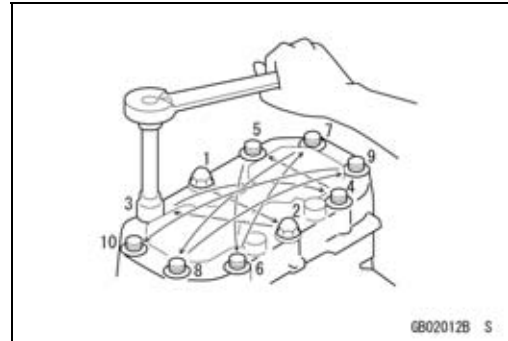

#### **Tightening Torque**

Incorrect torque applied to a bolt, nut, or screw may lead to serious damage. Tighten fasteners to the specified torque using a good quality torque wrench.

All of the tightening torque values are for use with dry, solvent - cleaned threads unless otherwise indicated. If a fastener which should have dry, clean threads gets contaminated with lubricant, etc., applying even the specified torque could damage it.

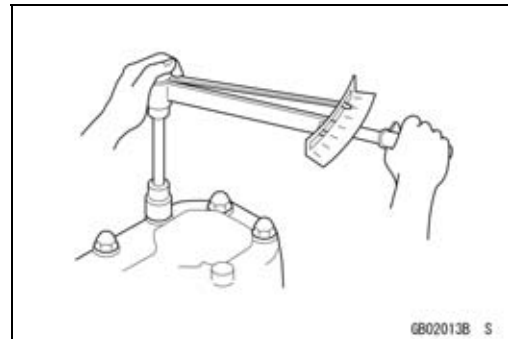

#### **Force**

Use common sense during disassembly and assembly, excessive force can cause expensive or hard to repair damage. When necessary, remove screws that have a non-permanent locking agent applied using an impact driver. Use a plastic-faced mallet whenever tapping is necessary.

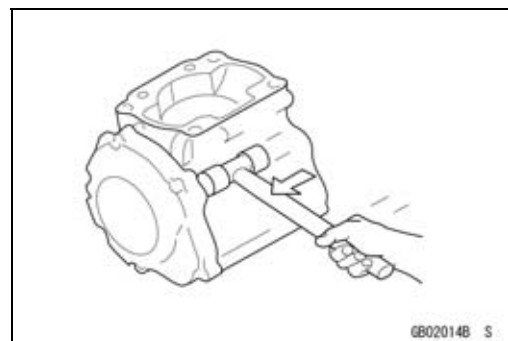

#### **Gasket, O-ring**

Hardening, shrinkage, or damage of both gaskets and O-rings after disassembly can reduce sealing performance. Remove old gaskets and clean the sealing surfaces thoroughly so that no gasket material or other material remains. Install the new gaskets and replace the used O-rings when re-assembling.

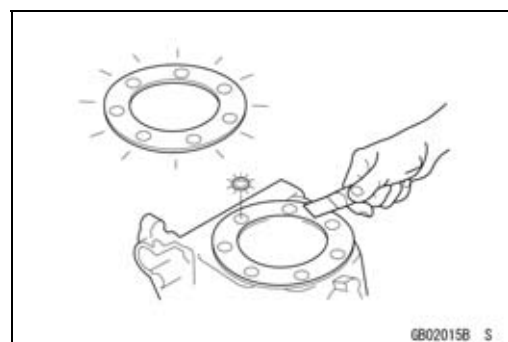

#### **Liquid Gasket, Non-permanent Locking Agent**

For applications that require Liquid Gasket or a Non-permanent Locking Agent, clean the surfaces so that no oil residue remains before applying liquid gasket or non-permanent locking agent. Do not apply them excessively. Excessive application can clog oil passages and cause serious damage.



**Before Servicing**

**Press**

For items such as bearings or oil seals that must be pressed into place, apply small amount of oil to the contact area. Be sure to maintain proper alignment and use smooth movements when installing.

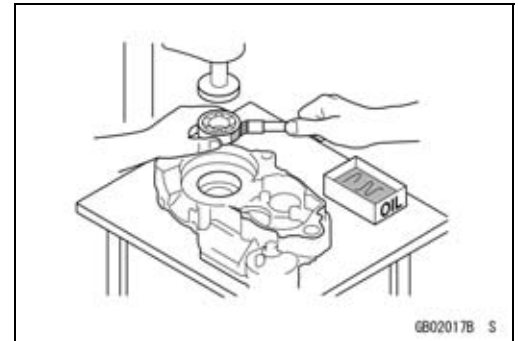

**Ball Bearing and Needle Bearing**

Do not remove pressed ball or needle unless removal is absolutely necessary. Replace with new ones whenever removed. Press bearings with the manufacturer and size marks facing out. Press the bearing into place by putting pressure on the correct bearing race as shown.

Pressing the incorrect race can cause pressure between the inner and outer race and result in bearing damage.

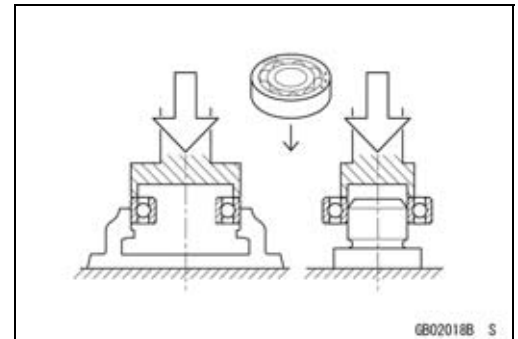

**Oil Seal, Grease Seal**

Do not remove pressed oil or grease seals unless removal is necessary. Replace with new ones whenever removed. Press new oil seals with manufacture and size marks facing out. Make sure the seal is aligned properly when installing.

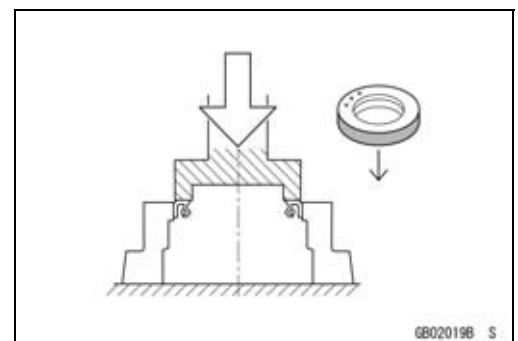

Apply specified grease to the lip of seal before installing the seal.

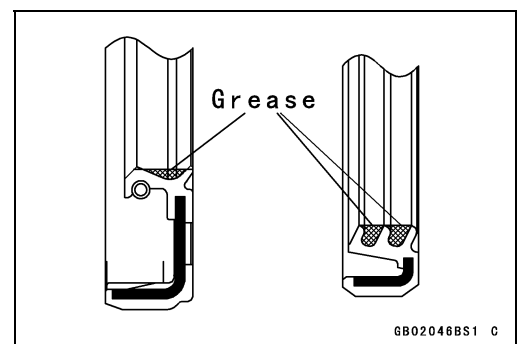

**Circlips, Cotter Pins**

Replace the circlips or cotter pins that were removed with new ones. Take care not to open the clip excessively when installing to prevent deformation.

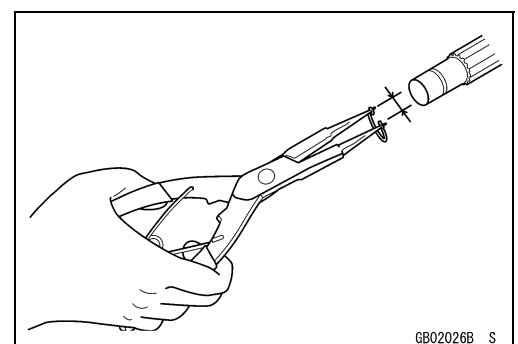

# 1-6 GENERAL INFORMATION

## Before Servicing

### **Lubrication**

It is important to lubricate rotating or sliding parts during assembly to minimize wear during initial operation. Lubrication points are called out throughout this manual, apply the specific oil or grease as specified.

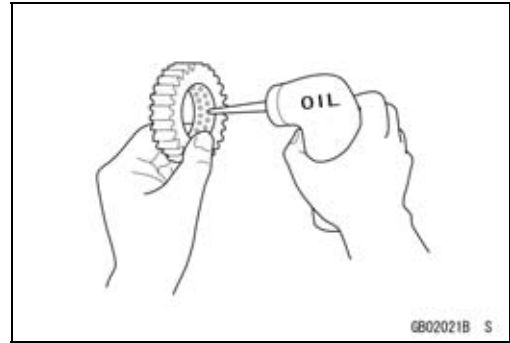

### **Direction of Engine Rotation**

When rotating the crankshaft by hand, the free play amount of rotating direction will affect the adjustment. Rotate the crankshaft to positive direction (clockwise viewed from output side).

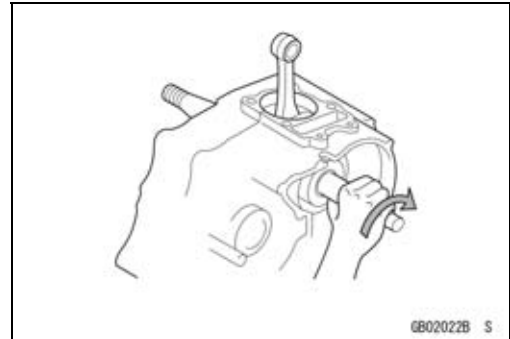

### **Electrical Wires**

A two-color wire is identified first by the primary color and then the stripe color. Unless instructed otherwise, electrical wires must be connected to those of the same color.

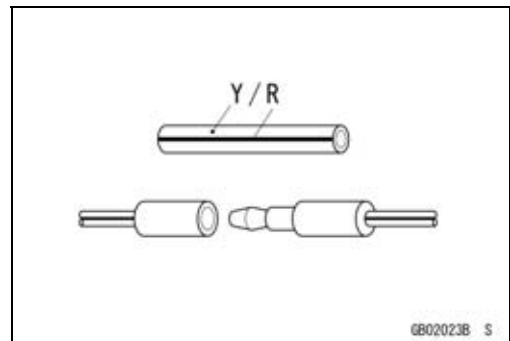

### **Instrument**

Use a meter that has enough accuracy for an accurate measurement. Read the manufacture's instructions thoroughly before using the meter. Incorrect values may lead to improper adjustments.

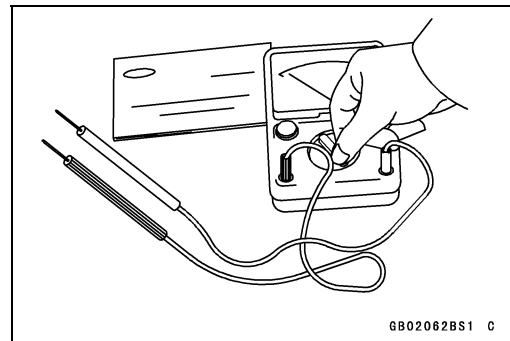



Model Identification

BR125GG Left Side View



BR125GG Right Side View



Frame Number



Engine Number



## 1-8 GENERAL INFORMATION

### Model Identification

BR125HG Left Side View



BR125HG Right Side View



Model Identification

BR125JH Left Side View



BR125JH Right Side View



# 1-10 GENERAL INFORMATION

## General Specifications

Items	BR125GG/HG/JH
<b>Dimensions</b>	
Overall Length	1 700 mm (66.93 in.)
Overall Width:	
BR125G	740 mm (29.1 in.)
BR125H/J	750 mm (29.5 in.)
Overall Height	1 005 mm (39.57 in.)
Wheelbase	1 175 mm (46.26 in.)
Road Clearance	155 mm (6.10 in.)
Seat Height:	
BR125G/H	780 mm (30.7 in.)
BR125J	805 mm (31.7 in.)
Curb Mass:	
BR125H/J	101 kg (223 lb)
Front	48 kg (106 lb)
Rear	53 kg (117 lb)
BR125J	102 kg (225 lb)
Front	48 kg (106 lb)
Rear	54 kg (119 lb)
Fuel Tank Capacity	7.4 L (2.0 US gal.)
<b>Performance</b>	
Minimum Turning Radius:	
BR125G/H	2.1 m (6.9 ft)
BR125J	2.3 m (7.5 ft)
<b>Engine</b>	
Type	4-stroke, SOHC, single-cylinder
Cooling System	Air-cooled
Bore and Stroke	56.0 × 50.6 mm (2.20 × 1.99 in.)
Displacement	125 cm <sup>3</sup> (7.63 cu in.)
Compression Ratio	9.8:1
Maximum Horsepower	(ID, PH) 6.9 kW (9.4 PS) @7 500 r/min (rpm) (TH) 7.0 kW (9.5 PS) @8 000 r/min (rpm) (MY) 7.2 kW (9.8 PS) @8 000 r/min (rpm) (AU) 7.1 kW (9.7 PS) @8 000 r/min (rpm) (US, CA, CAL) – – –
Maximum Torque	(ID, PH, TH) 9.5 N·m (0.97 kgf·m, 7.0 ft·lb) @6 000 r/min (rpm) (MY, AU) 9.6 N·m (0.98 kgf·m, 7.1 ft·lb) @6 000 r/min (rpm) (US, CA, CAL) – – –
Fuel System	FI (Fuel Injection), KEIHIN single barrel $\phi$ 24
Fuel Type:	
Minimum Octane Rating:	
Research Octane Number (RON)	91
Antiknock Index RON + MON)/2	87
Starting System	Electric starter
Ignition System	Battery and coil (transistorized)

General Specifications

Items	BR125GG/HG/JH
Timing Advance Ignition Timing Spark Plug Valve Timing: Intake: Open Close Duration Exhaust: Open Close Duration Lubrication System Engine Oil: Type Viscosity Capacity	Electronically advanced (IC igniter in ECU) 10° BTDC @1 500 r/min (rpm) to 37° BTDC @8 000 r/min (rpm) NGK CR6HSA  17° BTDC 55° ABDC 252°  56° BBDC 16° ATDC 252°  Forced lubrication (wet sump)  API SG, SH, SJ, SL or SM with JASO MA, MA1 or MA2 SAE 10W-40 1.0 L (1.1 US qt)
<b>Drive Train</b> Primary Reduction System: Type Reduction Ratio Clutch Type: BR125G BR125H/J Transmission: Type Gear Ratios: 1st 2nd 3rd 4th Final Drive System: Type Reduction Ratio Overall Drive Ratio	Gear 3.409 (75/22)  Centrifugal and wet multi disc Wet multi disc  4-speed, constant mesh, return shift  3.000 (36/12) 1.938 (31/16) 1.350 (27/20) 1.087 (25/23)  Chain drive 2.143 (30/14) 7.940 @Top gear
<b>Frame</b> Type Caster (Rake Angle) Trail Front Tire: Type Size Rim Size	Backbone 26° 69 mm (2.7 in.)  Tubeless 100/90-12 49J J12 × MT2.50

## 1-12 GENERAL INFORMATION

### General Specifications

Items	BR125GG/HG/JH
<b>Rear Tire:</b> Type Size Rim Size <b>Front Suspension:</b> Type Wheel Travel <b>Rear Suspension:</b> Type Wheel Travel <b>Brake Type:</b> Front Rear	Tubeless 120/70-12 51L J12 × MT3.50 Telescopic fork (upside-down) 100 mm (3.94 in.) Swingarm (mono-shock) 104 mm (4.09 in.) Single disc Single disc
<b>Electrical Equipment</b> Battery <b>Headlight:</b> High Beam Low Beam <b>Brake/Tail Light</b> <b>Alternator:</b> Type Maximum Output	12 V 3 Ah (10 HR)  12 V 35 W 12 V 35 W LED Single-phase AC 14 V – 11.7 A @10 000 r/min (rpm)

Specifications are subject to change without notice, and may not apply to every country.

**Unit Conversion Table**

**Prefixes for Units:**

Prefix	Symbol	Power
mega	M	× 1 000 000
kilo	k	× 1 000
centi	c	× 0.01
milli	m	× 0.001
micro	μ	× 0.000001

**Units of Mass:**

kg	×	2.205	=	lb
g	×	0.03527	=	oz

**Units of Volume:**

L	×	0.2642	=	gal (US)
L	×	0.2200	=	gal (IMP)
L	×	1.057	=	qt (US)
L	×	0.8799	=	qt (IMP)
L	×	2.113	=	pint (US)
L	×	1.816	=	pint (IMP)
mL	×	0.03381	=	oz (US)
mL	×	0.02816	=	oz (IMP)
mL	×	0.06102	=	cu in.

**Units of Force:**

N	×	0.1020	=	kg
N	×	0.2248	=	lb

---

kg	×	9.807	=	N
kg	×	2.205	=	lb

**Units of Length:**

km	×	0.6214	=	mile
m	×	3.281	=	ft
mm	×	0.03937	=	in.

**Units of Torque:**

N·m	×	0.1020	=	kgf·m
N·m	×	0.7376	=	ft·lb
N·m	×	8.851	=	in·lb

---

kgf·m	×	9.807	=	N·m
kgf·m	×	7.233	=	ft·lb
kgf·m	×	86.80	=	in·lb

**Units of Pressure:**

kPa	×	0.01020	=	kgf/cm <sup>2</sup>
kPa	×	0.1450	=	psi
kPa	×	0.7501	=	cmHg

---

kgf/cm <sup>2</sup>	×	98.07	=	kPa
kgf/cm <sup>2</sup>	×	14.22	=	psi
cmHg	×	1.333	=	kPa

**Units of Speed:**

km/h	×	0.6214	=	mph
------	---	--------	---	-----

**Units of Power:**

kW	×	1.360	=	PS
kW	×	1.341	=	HP

---

PS	×	0.7355	=	kW
PS	×	0.9863	=	HP

**Units of Temperature:**

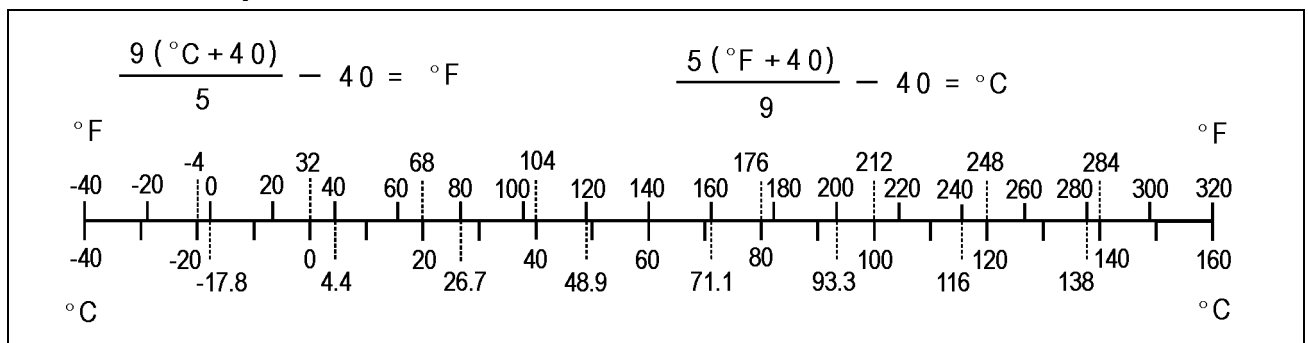





# Periodic Maintenance

## Table of Contents

Periodic Maintenance Chart .....	2-2	Drive Chain Wear Inspection .....	2-25
Torque and Locking Agent .....	2-4	Chain Guide Wear Inspection .....	2-25
Specifications .....	2-8	Brakes.....	2-26
Special Tools .....	2-10	Brake System Inspection .....	2-26
Periodic Maintenance Procedures.....	2-11	Brake Operation Inspection .....	2-27
Fuel System (DFI).....	2-11	Brake Fluid Level Inspection.....	2-27
Air Cleaner Element Cleaning.....	2-11	Brake Fluid Change .....	2-28
Air Cleaner Element		Brake Hose Replacement.....	2-30
Replacement .....	2-12	Master Cylinder Rubber Parts	
Idle Speed Inspection .....	2-13	Replacement.....	2-31
Idle Speed Adjustment.....	2-13	Caliper Rubber Parts	
Throttle Control System		Replacement.....	2-32
Inspection.....	2-14	Brake Pad Wear Inspection .....	2-36
Fuel System Inspection.....	2-14	Brake Light Switch Operation	
Fuel Hose Replacement .....	2-15	Inspection.....	2-36
Evaporative Emission Control		Suspension .....	2-37
System Inspection (CAL Model)	2-16	Suspension System Inspection....	2-37
Engine Top End .....	2-17	Lubrication of Rear Suspension...	2-38
Valve Clearance Inspection .....	2-17	Steering .....	2-38
Valve Clearance Adjustment.....	2-19	Steering Play Inspection .....	2-38
Clutch.....	2-19	Steering Play Adjustment.....	2-39
Clutch Release Adjustment		Steering Stem Bearing	
(BR125G only) .....	2-19	Lubrication.....	2-39
Clutch Operation Inspection		Electrical System .....	2-40
(BR125H/J) .....	2-19	Lights and Switches Operation	
Engine Lubrication System .....	2-20	Inspection.....	2-40
Engine Oil Change.....	2-20	Headlight Aiming Inspection	
Oil Filter Replacement .....	2-21	(BR125G/H) .....	2-42
Wheels/Tires .....	2-21	Headlight Aiming Inspection	
Air Pressure Inspection.....	2-21	(BR125J).....	2-42
Wheels and Tires Inspection.....	2-22	Side Stand Switch Operation	
Wheel Bearing Damage		Inspection (BR125J).....	2-43
Inspection.....	2-23	Engine Stop Switch Operation	
Final Drive.....	2-23	Inspection.....	2-44
Drive Chain Lubrication Condition		Spark Plug Replacement .....	2-45
Inspection.....	2-23	Others .....	2-45
Drive Chain Slack Inspection .....	2-23	Chassis Parts Lubrication .....	2-45
Drive Chain Slack Adjustment .....	2-24	Condition of Bolts, Nuts and	
Wheel Alignment Inspection .....	2-24	Fasteners Tightness Inspection	2-47

## 2-2 PERIODIC MAINTENANCE

### Periodic Maintenance Chart

The scheduled maintenance must be done in accordance with this chart to keep the motorcycle in good running condition. **The initial maintenance is vitally important and must not be neglected.**

#### Periodic Inspection

\*A: Service at number of years shown or indicated odometer reading intervals, whichever comes first.

\*B: For higher odometer readings, repeat at the frequency interval established here.

\*C: Service more frequently when operating in severe conditions: dusty, wet, muddy, high speed, or frequent starting/stopping.

○: Emission Related Item

Q: Inspection

↻: Change or Replace

🔧: Lubrication

Items	year (*A)	Odometer Reading (*B) × 1 000 km (× 1 000 mile)					See Page
		1 (0.6)	6 (3.8)	12 (7.6)	18 (11.4)	24 (15.2)	
<b>Fuel System</b>							
○ Air cleaner element (*C)	↻:2			Q		Q	2-11, 2-12
○ Idle speed		Q		Q		Q	2-13
○ Throttle control system (play, smooth return, no drag)	Q:1	Q		Q		Q	2-14
Fuel system	Q:1	Q		Q		Q	2-14
Fuel hose	↻:5						2-15
○ Evaporative emission control system (CAL Model)		Q	Q	Q	Q	Q	2-16
<b>Engine Top End</b>							
○ Valve clearance				Q		Q	2-17
<b>Clutch</b>							
Clutch operation (play, engagement, disengagement)		Q		Q		Q	2-19
<b>Engine Lubrication System</b>							
Engine oil and oil filter (*C)	↻:1	↻		↻		↻	2-20, 2-21
<b>Wheels and Tires</b>							
Tire air pressure	Q:1			Q		Q	2-21
Wheel and tire	Q:1			Q		Q	2-22
Wheel bearing damage	Q:1			Q		Q	2-23
<b>Final Drive</b>							
Drive chain lubrication condition (*C)		Q: every 600 km (400 mile)					2-23
Drive chain slack (*C)		Q: every 1 000 km (600 mile)					2-23
Drive chain wear (*C)			Q	Q	Q	Q	2-25
Drive chain guide wear				Q		Q	2-25
<b>Brakes</b>							
Brake system	Q:1	Q		Q		Q	2-26

Periodic Maintenance Chart

Items	year (*A)	Odometer Reading (*B) × 1 000 km (× 1 000 mile)					See Page
		1 (0.6)	6 (3.8)	12 (7.6)	18 (11.4)	24 (15.2)	
Brake operation (effectiveness, play, no drag)	Q:1	Q		Q		Q	2-27
Brake fluid level	Q:1	Q		Q		Q	2-27
Brake fluid (front and rear)	↻:2					↻	2-28
Brake hose	↻:4						2-30
Rubber parts of brake master cylinder and caliper	↻:4	↻ every 48 000 km (30 000 mile)					2-31, 2-32
Brake pad wear (*C)			Q	Q	Q	Q	2-36
Brake light switch operation		Q	Q	Q	Q	Q	2-36
<b>Suspension</b>							
Suspension system	Q:1			Q		Q	2-37
Lubrication of rear suspension						↘	2-38
<b>Steering</b>							
Steering play	Q:1	Q		Q		Q	2-38
Steering stem bearing	↘:2					↘	2-39
<b>Electrical System</b>							
Electrical system	Q:1			Q		Q	2-40
○ Spark plug				↻		↻	2-45
<b>Others</b>							
Chassis parts	↘:1			↘		↘	2-45
Condition of bolts, nuts and fasteners		Q		Q		Q	2-47

## 2-4 PERIODIC MAINTENANCE

### Torque and Locking Agent

The following tables list the tightening torque for the major fasteners requiring use of a non-permanent locking agent or silicone sealant etc. All of the values are for use with dry solvent - cleaned threads unless otherwise indicated.

Letters used in the "Remarks" column mean:

G: Apply grease.

L: Apply a non-permanent locking agent.

R: Replacement Parts

S: Follow the specified tightening sequence.

Si: Apply silicone grease.

Fastener	Torque			Remarks
	N·m	kgf·m	ft·lb	
<b>Fuel System (DFI)</b>				
Right Switch Housing Screws	3.5	0.36	31 in·lb	
Air Cleaner Housing Mounting Screws (L = 14 mm)	5.2	0.53	46 in·lb	
Air Cleaner Housing Mounting Screw (L = 20 mm)	3.5	0.36	31 in·lb	
Fuel Pump Bolts	9.8	1.0	87 in·lb	L, S
Air Cleaner Cover Screws	1.2	0.12	11 in·lb	
Intake Pipe Bolts	12	1.2	106 in·lb	
Idle Speed Control Valve Actuator Screws	2.1	0.21	19 in·lb	
Throttle Body Assy Mounting Bolts	8.8	0.90	78 in·lb	
Air Cleaner Housing Clamp Screw	2.0	0.20	18 in·lb	
Purge Valve Nut	8.8	0.90	78 in·lb	
Purge Valve Bracket Bolt	8.8	0.90	78 in·lb	
Canister Bracket Bolt	8.8	0.90	78 in·lb	
Ignition Coil Mounting Bolts	4.0	0.41	35 in·lb	
Delivery Pipe Mounting Bolts	5.2	0.53	46 in·lb	
Spark Plug	13	1.3	115 in·lb	
Engine Temperature Sensor	9.8	1.0	87 in·lb	
Crankshaft Sensor Mounting Screws	2.9	0.30	26 in·lb	
Speed Sensor Bolt	5.2	0.53	46 in·lb	
Oxygen Sensor	25	2.5	18	
<b>Engine Top End</b>				
Valve Adjusting Cap Bolts	5.2	0.53	46 in·lb	
Cylinder Head Bolts	12	1.2	106 in·lb	L, S
Cylinder Head Nuts	22	2.2	16	S
Camshaft Sprocket Cover Bolts	5.2	0.53	46 in·lb	
Intake Pipe Bolts	12	1.2	106 in·lb	
Rocker Shaft Stopper Screws	5.2	0.53	46 in·lb	L
Camshaft Sprocket Bolts	12	1.2	106 in·lb	L
Camshaft Chain Guide Mounting Bolt	5.2	0.53	46 in·lb	
Camshaft Chain Holder Screws	5.2	0.53	46 in·lb	
Chain Tensioner Cap Bolt	5.2	0.53	46 in·lb	
Chain Tensioner Mounting Bolts	5.2	0.53	46 in·lb	L
Valve Adjusting Screw Locknuts	8.8	0.90	78 in·lb	
Exhaust Pipe Holder Nuts	14.7	1.50	10.8	

## PERIODIC MAINTENANCE 2-5

### Torque and Locking Agent

Fastener	Torque			Remarks
	N·m	kgf·m	ft·lb	
Muffler Body Mounting Bolt	16.5	1.68	12.2	
<b>Clutch</b>				
Clutch Cover Bolts	8.8	0.90	78 in·lb	S
Primary Clutch Hub Nut	72	7.3	53	
Secondary Clutch Spring Bolts	5.0	0.51	44 in·lb	
Secondary Clutch Hub Nut	72	7.3	53	
Clutch Adjusting Screw Locknut	19	1.9	14	
Primary Gear Nut	72	7.3	53	
Clutch Spring Bolts	5.0	0.51	44 in·lb	
Clutch Hub Nut	72	7.3	53	
<b>Engine Lubrication System</b>				
Oil Pipe Banjo Bolts	15	1.5	11	
Oil Pipe Mounting Screw	5.2	0.53	46 in·lb	
Oil Pump Mounting Screws	5.2	0.53	46 in·lb	
Oil Filter Cap Bolts	5.2	0.53	46 in·lb	
Engine Oil Drain Bolt	29	3.0	21	
<b>Engine Removal/Installation</b>				
Engine Mounting Nuts	59	6.0	44	
<b>Crankshaft/Transmission</b>				
Crankcase Studs	12	1.2	106 in·lb	L (1)
Shift Shaft Return Spring Pin	22	2.2	16	L
Drive Shaft Bearing Retaining Screw	5.2	0.53	46 in·lb	L
Shift Drum Bearing Retaining Screws	2.9	0.30	26 in·lb	L
Starter Motor Clutch Bolts	11.8	1.20	104 in·lb	L
Crankcase Screws (L = 50 mm)	5.2	0.53	46 in·lb	S
Crankcase Screws (L = 75 mm)	5.2	0.53	46 in·lb	L (1), S
Shift Drum Positioning Lever Pivot Bolt	5.2	0.53	46 in·lb	
Shift Drum Positioning Plate Screw	5.2	0.53	46 in·lb	
Shift Lever Bolt	12	1.2	106 in·lb	
Shift Pedal Mounting Bolt	22	2.2	16	G, L
Shift Drum Cam Bolt	5.2	0.53	46 in·lb	L
<b>Wheels/Tires</b>				
Front Axle Nut	64	6.5	47	R
Rear Axle Nut	64	6.5	47	R
<b>Final Drive</b>				
Engine Sprocket Cover Bolts	5.2	0.53	46 in·lb	
Rear Sprocket Nuts	34	3.5	25	
<b>Brakes</b>				
Brake Hose Banjo Bolts	25	2.5	18	
Front Brake Reservoir Cap Screws	1.5	0.15	13 in·lb	
Brake Lever Pivot Bolt	5.9	0.60	52 in·lb	Si
Brake Lever Pivot Bolt Locknut	5.9	0.60	52 in·lb	
Front Master Cylinder Clamp Bolts	8.8	0.90	78 in·lb	S

## 2-6 PERIODIC MAINTENANCE

### Torque and Locking Agent

Fastener	Torque			Remarks
	N·m	kgf·m	ft·lb	
Front Brake Light Switch Screw	1.2	0.12	11 in·lb	
Front Caliper Holder Pin	17.2	1.75	12.7	Si
Bleed Valve	7.8	0.80	69 in·lb	
Front Caliper Pad Pin Plug	2.5	0.25	22 in·lb	
Front Caliper Pad Pin	17.2	1.75	12.7	
Front Caliper Mounting Bolts	25	2.5	18	
Front Brake Disc Mounting Bolts	27	2.8	20	L, S
Front Caliper Holder Pin Nut	22.1	2.25	16.3	L
Rear Master Cylinder Mounting Bolts	8.8	0.90	78 in·lb	
Rear Caliper Pad Pins	17.2	1.75	12.7	
Rear Caliper Mounting Bolts	25	2.5	18	
Rear Caliper Holder Pin	17.2	1.75	12.7	Si
Rear Brake Disc Mounting Bolts	27	2.8	20	L, S
Rear Master Cylinder Push Rod Locknut	17.2	1.75	12.7	
<b>Suspension</b>				
Front Fork Top Plugs (for Outer Tube)	22.5	2.29	16.6	
Front Fork Top Plugs (for Cylinder Unit)	23	2.3	17	
Set Screws	1.4	0.14	12 in·lb	
Front Fork Clamp Bolts (Upper)	20	2.0	15	
Front Fork Clamp Bolts (Lower)	20	2.0	15	
Rear Shock Absorber Bolts	59	6.0	44	
Swingarm Pivot Shaft Nut	88	9.0	65	
<b>Steering</b>				
Handlebar Clamp Bolts	25	2.5	18	S
Left Switch Housing Screws	3.5	0.36	31 in·lb	
Right Switch Housing Screws	3.5	0.36	31 in·lb	
Steering Stem Head Nut	44	4.5	32	
Front Fork Clamp Bolts (Upper)	20	2.0	15	
Steering Stem Nut	7.4	0.75	65 in·lb	S
Front Fork Clamp Bolts (Lower)	20	2.0	15	
<b>Frame</b>				
Front Footpeg Bracket Bolts	25	2.5	18	
Side Stand Bolt	29	3.0	21	G, S
Side Stand Nut	44	4.5	32	R, S
Alternator Cover Bolts	8.8	0.90	78 in·lb	S
Reflector Nut	3.4	0.35	30 in·lb	
<b>Electrical System</b>				
Turn Signal Light Bracket Screws	1.0	0.10	8.9 in·lb	
Turn Signal Light Lens Screws	1.0	0.10	8.9 in·lb	
License Plate Light Mounting Screws	1.5	0.15	13 in·lb	
Ignition Coil Mounting Bolts	4.0	0.41	35 in·lb	
Spark Plug	13	1.3	115 in·lb	
Starter Motor Mounting Screws	5.2	0.53	46 in·lb	

**Torque and Locking Agent**

Fastener	Torque			Remarks
	N·m	kgf·m	ft·lb	
Starter Motor Brush Holder Plate Screws	0.89	0.091	7.9 in·lb	
Starter Motor Terminal Plate Screws	2.0	0.20	18 in·lb	
Starter Motor Terminal Screw	2.0	0.20	18 in·lb	
Starter Motor End Cover Screws	4.4	0.45	39 in·lb	
Regulator/Rectifier Mounting Bolts	9.8	1.0	87 in·lb	L
Speed Sensor Bolt	5.2	0.53	46 in·lb	
Starter Motor Clutch Bolts	11.8	1.20	104 in·lb	L
Alternator Rotor Nut	53.9	5.50	39.8	
Stator Coil Mounting Screws	5.2	0.53	46 in·lb	
Crankshaft Sensor Mounting Screws	2.9	0.30	26 in·lb	
Alternator Lead Clamp Screws	5.2	0.53	46 in·lb	
Alternator Cover Bolts	8.8	0.90	78 in·lb	S
Timing Inspection Cap	2.4	0.24	21 in·lb	
Alternator Rotor Nut Cap	2.4	0.24	21 in·lb	
Oxygen Sensor	25	2.5	18	
Gear Position Switch Mounting Screws	2.9	0.30	26 in·lb	
Front Brake Light Switch Screw	1.2	0.12	11 in·lb	
Left Switch Housing Screws	3.5	0.36	31 in·lb	
Right Switch Housing Screws	3.5	0.36	31 in·lb	
Fuel Pump Bolts	9.8	1.0	87 in·lb	L, S
Engine Temperature Sensor	9.8	1.0	87 in·lb	

The table below, relating tightening torque to thread diameter, lists the basic torque for the bolts and nuts. Use this table for only the bolts and nuts which do not require a specific torque value. All of the values are for use with dry solvent-cleaned threads.

**Basic Torque for General Fasteners**

Threads Diameter (mm)	Torque		
	N·m	kgf·m	ft·lb
5	3.4 ~ 4.9	0.35 ~ 0.50	30 ~ 43 in·lb
6	5.9 ~ 7.8	0.60 ~ 0.80	52 ~ 69 in·lb
8	14 ~ 19	1.4 ~ 1.9	10 ~ 13.5
10	25 ~ 34	2.6 ~ 3.5	19 ~ 25
12	44 ~ 61	4.5 ~ 6.2	33 ~ 45
14	73 ~ 98	7.4 ~ 10.0	54 ~ 72
16	115 ~ 155	11.5 ~ 16.0	83 ~ 115
18	165 ~ 225	17.0 ~ 23.0	125 ~ 165
20	225 ~ 325	23.0 ~ 33.0	165 ~ 240

## 2-8 PERIODIC MAINTENANCE

### Specifications

Item	Standard	Service Limit
<b>Fuel System (DFI)</b>		
Throttle Grip Free Play	2 ~ 3 mm (0.08 ~ 0.12 in.)	---
Idle Speed	1 500 ±50 r/min (rpm)	---
Air Cleaner Element	Polyurethane foam element	---
Air Cleaner Element Oil	High-quality foam air filter oil	---
<b>Engine Top End</b>		
Valve Clearance:		
Exhaust	0.08 ~ 0.12 mm (0.0031 ~ 0.0047 in.)	---
Intake	0.04 ~ 0.08 mm (0.0016 ~ 0.0031 in.)	---
<b>Clutch</b>		
Clutch Release (BR125G)	1/4 turn out	---
Clutch Lever Free Play (BR125H/J)	2 ~ 3 mm (0.08 ~ 0.12 in.)	---
<b>Engine Lubrication System</b>		
Engine Oil:		
Type	API SG, SH, SJ, SL or SM with JASO MA, MA1 or MA2	---
Viscosity	SAE 10W-40	---
Capacity	0.8 L (0.8 US qt) (When filter is not removed)	---
	0.9 L (1.0 US qt) (When filter is removed)	---
	1.0 L (1.1 US qt) (When engine is completely dry)	---
Level	Between upper and lower level lines on the dipstick (Wait several minutes after idling or running)	---
<b>Wheels/Tires</b>		
Tread Depth:		
Front	4.2 mm (0.17 in.)	1 mm (0.04 in.)
Rear	4.7 mm (0.19 in.)	Up to 130 km/h (80 mph): 2 mm (0.08 in.), Over 130 km/h (80 mph): 3 mm (0.12 in.)
Air Pressure (when Cold):		
Front	150 kPa (1.50 kgf/cm <sup>2</sup> , 22 psi)	---
Rear	200 kPa (2.00 kgf/cm <sup>2</sup> , 29 psi)	---
<b>Final Drive</b>		
Drive Chain Slack	20 ~ 35 mm (0.8 ~ 1.4 in.)	---
Drive Chain Wear (20-link Length)	254.0 ~ 254.6 mm (10.00 ~ 10.02 in.)	259 mm (10.2 in.)
Standard Chain:		
Make	DAIDO	---
Type	DID420AD	---
Link	100 links	---



**Specifications**

Item	Standard	Service Limit
<b>Brakes</b>		
Brake Fluid:		
Grade:		
Front	DOT3 or DOT4	- - -
Rear	DOT3	- - -
Brake Pad Lining		
Thickness:		
Front	4.0 mm (0.16 in.)	1 mm (0.04 in.)
Rear	4.5 mm (0.18 in.)	1 mm (0.04 in.)
Brake Light Timing:		
Front	Pulled ON	- - -
Rear	ON after about 10 mm (0.39 in.) of pedal travel	- - -
<b>Electrical System</b>		
Spark Plug:		
Type	NGK CR6HSA	- - -
Gap	0.6 ~ 0.7 mm (0.024 ~ 0.028 in.)	- - -

## 2-10 PERIODIC MAINTENANCE

### Special Tools

---

**Inside Circlip Pliers:**

**57001-143**

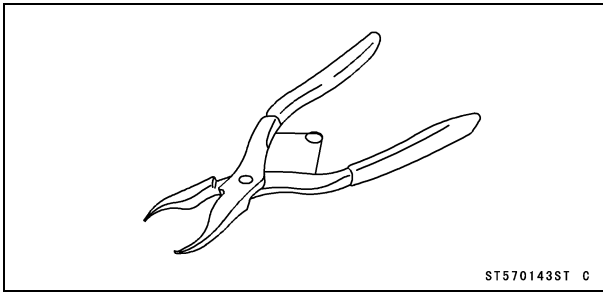

**Steering Stem Nut Wrench:**

**57001-1100**

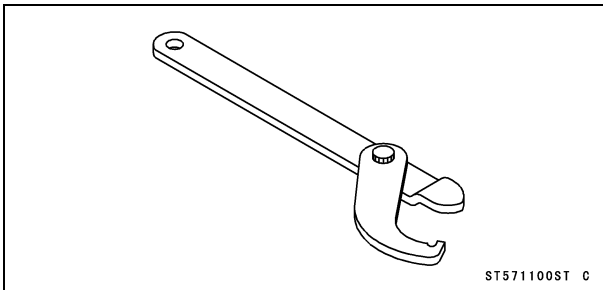

**Valve Adjusting Screw Holder:**

**57001-1217**

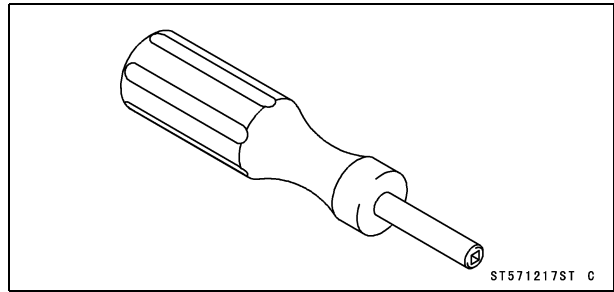

**Spark Plug Wrench, Hex 16:**

**57001-1262**

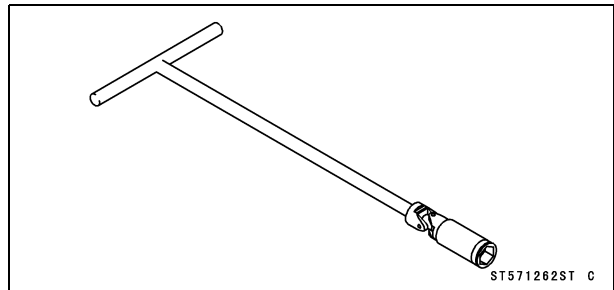

Periodic Maintenance Procedures

Fuel System (DFI)

**Air Cleaner Element Cleaning**

**NOTE**

○ In dusty areas, the element should be cleaned more frequently than the recommended interval.

**⚠ WARNING**

If dirt or dust is allowed to pass through into the throttle body assy, the throttle may become stuck, possibly causing accident. Replace the air cleaner element according to the maintenance chart.

**NOTICE**

If dirt gets through into the engine, excessive engine wear and possibly engine damage will occur.

- Remove the element [A] (see Air Cleaner Element Replacement).

**⚠ WARNING**

Gasoline and low flash-point solvents can be flammable and/or explosive and cause severe burns. Clean the element in a well-ventilated area, and take care that there is no spark or flame anywhere near the working areas. Do not use gasoline or low flash-point solvents to clean the element.

- Clean the element in a bath of high flash-point solvent.
- Squeeze it dry in a clean towel [A]. Do not wring the element or blow it dry; the element can be damaged.
- Check all the parts of the element for visible damage.
- ★ If any of the parts of the element are damaged, replace them.

- After cleaning, saturate the element with a high-quality foam-air-filter oil, squeeze out the excess, then wrap it in a clean towel and squeeze it as dry as possible.

○ Be careful not to tear the element.

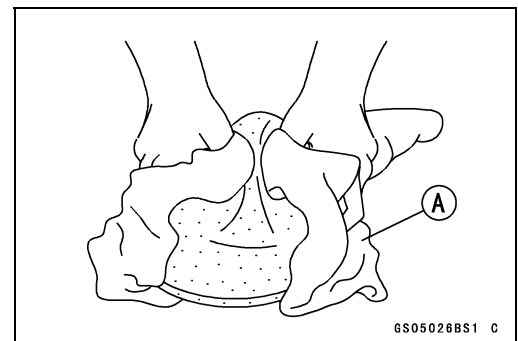
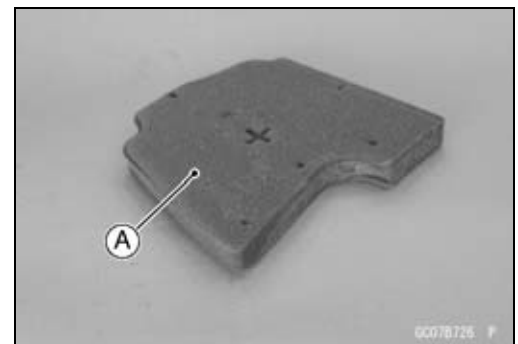

## 2-12 PERIODIC MAINTENANCE

### Periodic Maintenance Procedures

#### Air Cleaner Element Replacement

##### NOTE

○In dusty areas, the element should be replaced more frequently than the recommended interval.

##### **⚠ WARNING**

If dirt or dust is allowed to pass through into the throttle body assy, the throttle may become stuck, possibly causing accident. Replace the air cleaner element according to the maintenance chart.

##### **NOTICE**

If dirt gets through into the engine, excessive engine wear and possibly engine damage will occur.

- Disconnect:  
Horn Lead Connectors [A]
- Remove:  
Bolt [B]  
Horn [C]

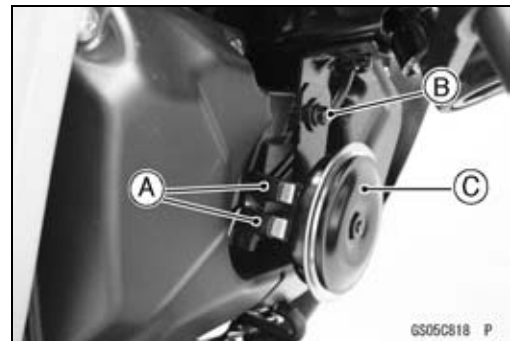

- Remove:  
Air Cleaner Cover Screws [A]  
Air Cleaner Cover [B]

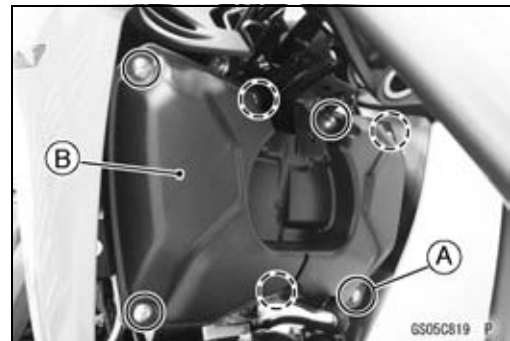

- Remove:  
Air Cleaner Element [A]  
Wire Screen

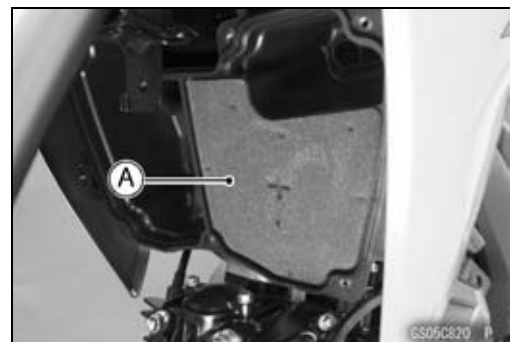

**Periodic Maintenance Procedures**

- Apply grease to the lateral side of new element [A] as shown.  
10 mm (0.39 in.) [B]

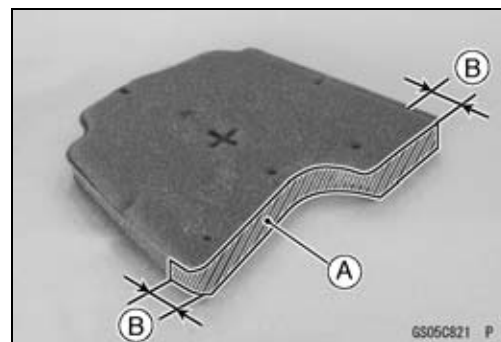

- Install:  
Wire Screen [A]  
Element [B]  
Air Cleaner Cover
- Tighten:  
**Torque - Air Cleaner Cover Screws: 1.2 N·m (0.12 kgf·m, 11 in·lb)**
- Install the horn.
- Connect the horn lead connectors.

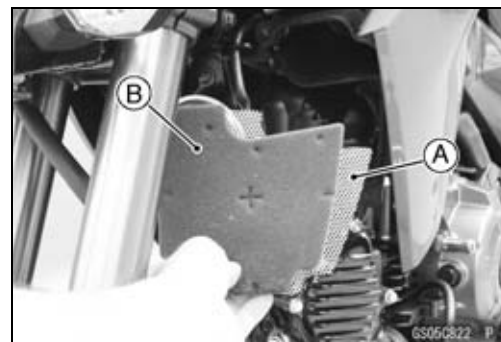

**Idle Speed Inspection**

- Start the engine and warm it up thoroughly.
- With the engine idling, turn the handlebars to both sides [A].
- ★ If handlebars movement changes the idle speed, the throttle cable may be improperly adjusted or incorrectly routed, or damaged. Be sure to correct any of these conditions before riding (see Throttle Control System Inspection and Cable, Wire, and Hose Routing section in the Appendix chapter).

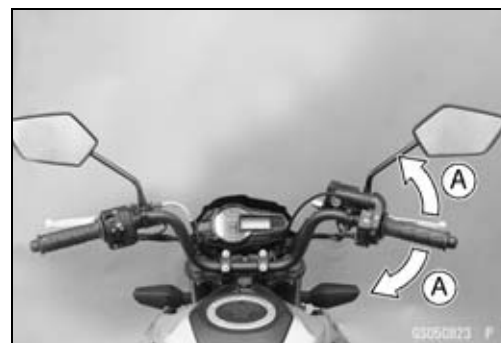

**⚠ WARNING**

**Operation with improperly adjusted, incorrectly routed or damaged cable could result in an unsafe riding condition. Follow the service manual to make sure to correct any of these conditions.**

- Check the idle speed.
- ★ If the idle speed is out of specified range, check the idle speed control valve actuator (see Idle Speed Control Valve Actuator Resistance Inspection in the Fuel System (DFI) chapter).

**Idle Speed**

**Standard: 1 500 ±50 r/min (rpm)**

**Idle Speed Adjustment**

**NOTE**

○ This motorcycle is equipped with the idle speed control valve actuator. The idle speed is adjusted automatically at the specified value (1 500 r/min (rpm)) by the idle speed control valve system. Therefore, it is not necessary to adjust the idle speed normally.

## 2-14 PERIODIC MAINTENANCE

### Periodic Maintenance Procedures

#### Throttle Control System Inspection

- Check that the throttle grip [A] moves smoothly from full open to close, and the throttle closes quickly and completely by the return spring in all steering positions.
- ★ If the throttle grip does not return properly, check the throttle cable routing, grip free play, and cable damage. Then lubricate the throttle cable.
- Check the throttle grip free play [B].

#### Throttle Grip Free Play

Standard: 2 ~ 3 mm (0.08 ~ 0.12 in.)

- ★ If the free play is incorrect, adjust the throttle cable as follows.
  - Slide the dust cover [A].
  - Loosen the locknut [B].
  - Turn the throttle cable adjuster [C] until 2 ~ 3 mm (0.08 ~ 0.12 in.) of throttle grip play is obtained.
  - Tighten the locknut.

- ★ If the free play can not be adjusted with the adjuster. Use the adjuster in the lower end of the throttle cable.
  - Remove:
    - Right Side/Frame Cover (see Side/Frame Cover Removal in the Frame chapter).
  - Loosen the upper nut [A].
  - Turn the lower nut [B] until 2 ~ 3 mm (0.08 ~ 0.12 in.) of throttle grip play is obtained.
  - Tighten the upper nut.

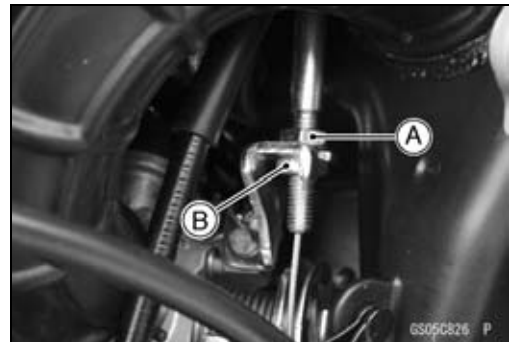
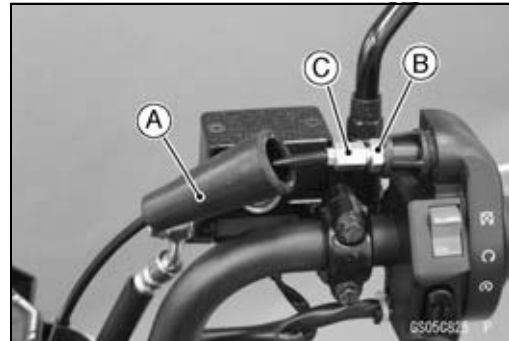
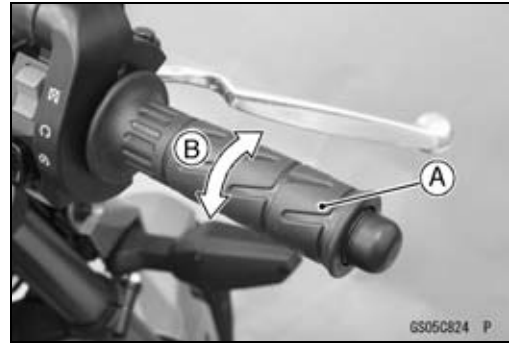

#### Fuel System Inspection

#### Fuel Hose Inspection (fuel leak, damage, installation condition)

- If the motorcycle is not properly handled, the high pressure inside the fuel line can cause fuel to leak [A] or the hose to burst. Remove the fuel tank (see Fuel Tank Removal in the Fuel System (DFI) chapter) and check the fuel hose.
- ★ Replace the fuel hose if any fraying, cracks [B] or bulges [C] are noticed.
- Check that the fuel hose is routed according to Cable, Wire, and Hose Routing section in the Appendix chapter.
- ★ Replace the hose if it has been sharply bent or kinked.
  - Hose Joints [A]
  - Fuel Hose [B]

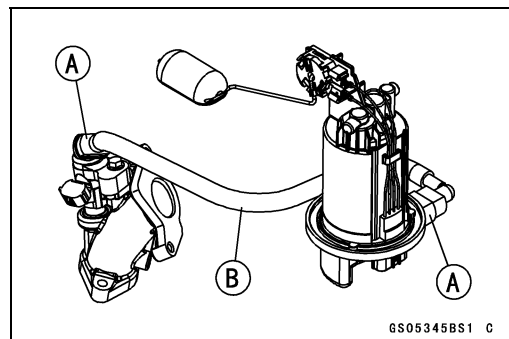
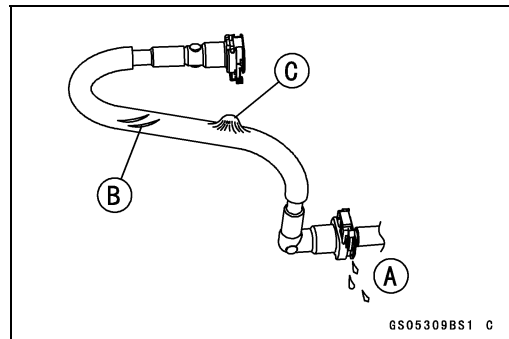

**Periodic Maintenance Procedures**

- Check that the fuel hose joints are securely connected.
- Push and pull [A] the fuel hose joint [B] back and forth more than two times, and make sure it is locked.

**NOTICE**

When pushing and pulling the fuel hose joint, do not apply strong force to the delivery pipes [C]. The pipe made from resin could be damaged.

**⚠ WARNING**

Leaking fuel can cause a fire or explosion resulting in serious burns. Make sure the hose joint is installed correctly on the delivery pipe by sliding the joint.

★ If it is not locked, reinstall the hose joint.

**Fuel Hose Replacement**

- Remove the fuel tank (see Fuel Tank Removal in the Fuel System (DFI) chapter).
- Be sure to place a piece of cloth around the fuel hose joint.
- Wipe off the dirt of the surface [A] around the connection using a cloth or a soft brush.

- Insert the flat tip screwdriver [A] into slit on the joint lock [B].
- Turn the driver to disconnect the joint lock.

- Pull the fuel hose joint [A] out of the delivery pipe.

**⚠ WARNING**

Fuel is flammable and explosive under certain conditions and can cause severe burns. Be prepared for fuel spillage; any spilled fuel must be completely wiped up immediately. When the fuel hose is disconnected, fuel spills out from the hose and the pipe because of residual pressure. Cover the hose connection with a piece of clean cloth to prevent fuel spillage.

- Clean the delivery pipe.
- Cover the delivery pipe with the vinyl bag to keep it clean.

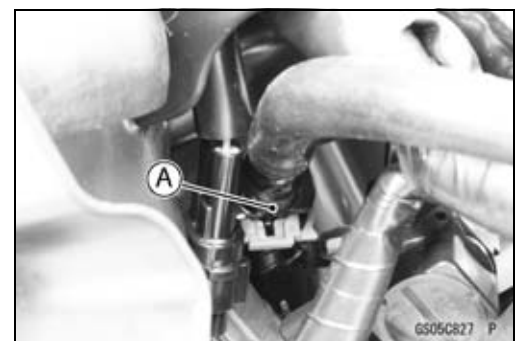
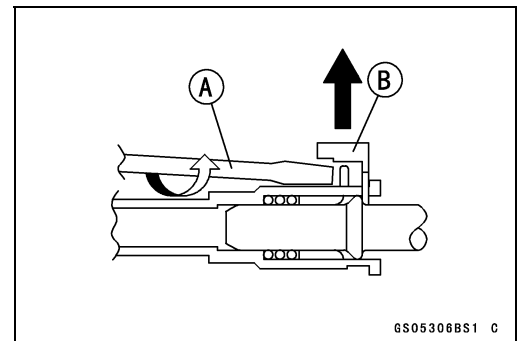
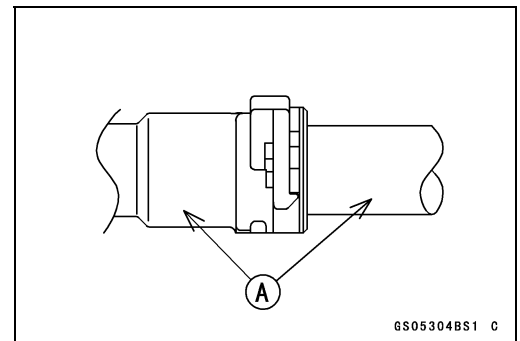
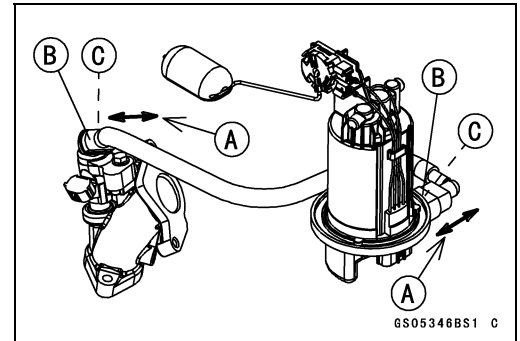

## 2-16 PERIODIC MAINTENANCE

### Periodic Maintenance Procedures

- Remove the vinyl bag on the pipe.
- Check that there are no flaws, burrs, and adhesion of foreign materials on the delivery pipe [A].

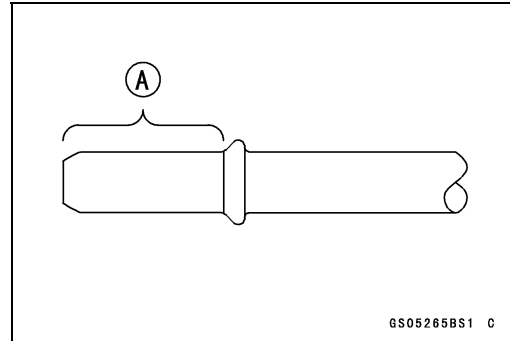

- Replace the fuel hose with a new one.
- Run the fuel hose correctly (see Cable, Wire, and Hose Routing section in the Appendix chapter).
- Insert [A] the fuel hose joint [B] straight onto the delivery pipe.
- Push [C] the joint lock [D].

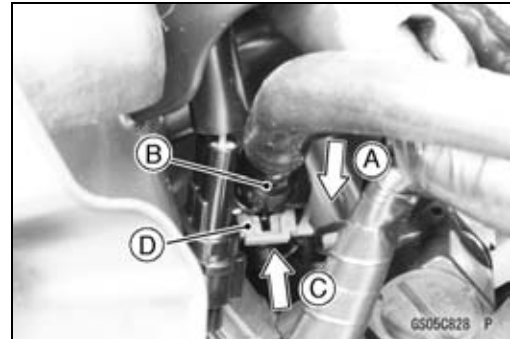

- Push and pull [A] the fuel hose joint [B] back and forth more than two times and make sure it is locked and does not come off.

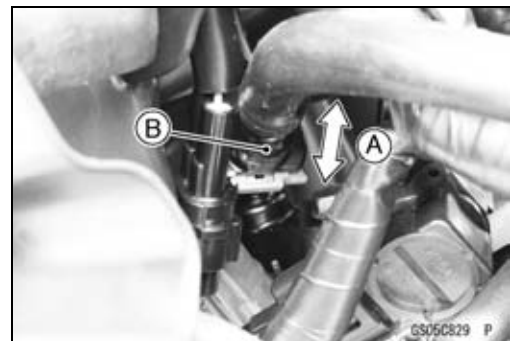

#### NOTICE

When pushing and pulling the fuel hose joint, do not apply strong force to the delivery pipe. The pipe made from resin could be damaged.

#### ⚠ WARNING

Leaking fuel can cause a fire or explosion resulting in severe burns. Make sure the fuel hose joint is installed correctly on the delivery pipe and that it doesn't leak.

- ★ If it comes off, reinstall the hose joint.
- Install the fuel tank (see Fuel Tank Installation in the Fuel System (DFI) chapter).
- Start the engine and check the fuel hose for leaks.

#### Evaporative Emission Control System Inspection (CAL Model)

- Inspect the canister as follows.
  - Remove the left side/frame cover (see Side/Frame Cover Removal in the Frame chapter).
  - Slide the clamps [A].
  - Disconnect the hoses [B].

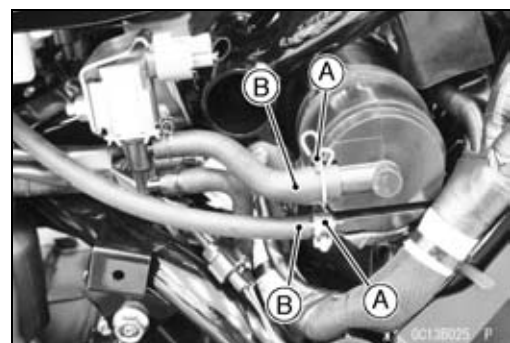



**Periodic Maintenance Procedures**

- Remove:
  - Canister Bracket Bolts [A]
  - Clamp [B]
  - Bracket and Canister [C]

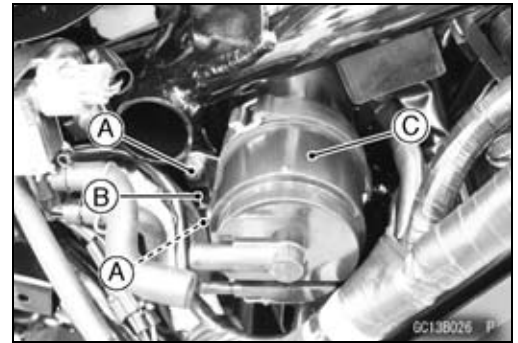

- Remove:
  - Band [A]
  - Bracket [B]
  - Canister [C]



- Visually inspect the canister for cracks or other damage.
- ★If the canister has any cracks or bad damage, replace it with a new one.

**NOTE**

- The canister is designed to work well through the motorcycle's life without any maintenance if it is used under normal conditions.
- Inspect the purge valve (see Purge Valve Inspection in the Fuel System (DFI) chapter).
- Check that the hoses are securely connected and clips are in position.
- Replace any kinked, deteriorated or damaged hoses.
- Run the hoses according to Cable, Wire, and Hose Routing section in the Appendix chapter.
- When installing the hoses, avoid sharp bending, kinking, flattening or twisting, and run the hoses with a minimum of bending so that the emission flow will not be obstructed.

**Engine Top End**

**Valve Clearance Inspection**

<b>NOTICE</b>
<b>If valve clearance is left unadjusted, the wear will eventually cause the valves to remain partly open, which lowers performance, burns the valves and the valve seats, and may cause serious engine damage.</b>

**NOTE**

- Valve clearance must be checked when the engine is cold (at room temperature).

## 2-18 PERIODIC MAINTENANCE

### Periodic Maintenance Procedures

- Remove:
  - Alternator Rotor Nut Cap [A]
  - Timing Inspection Cap [B]

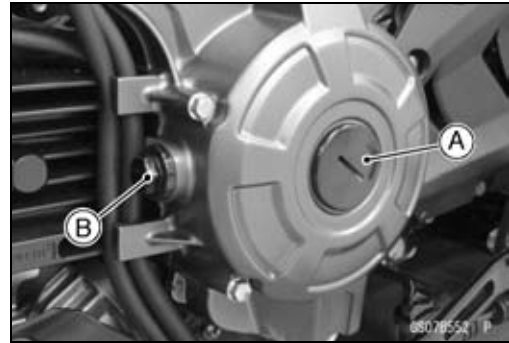

- Remove:
  - Valve Adjusting Cap Bolts [A]
  - Valve Adjusting Caps [B]

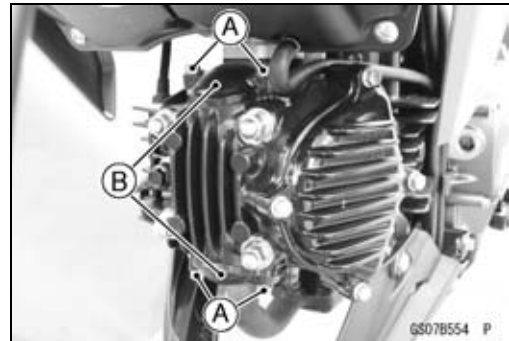

- Turn the alternator rotor nut counterclockwise to align the "T" mark line [A] on the rotor with the notch [B] of the alternator cover. When doing this, turn the crankshaft so that the piston comes to the TDC (top dead center) in the compression stroke when the marks are aligned.

#### NOTE

○Align the "T" mark after the intake valve (rocker arm) has moved down and then moved up.

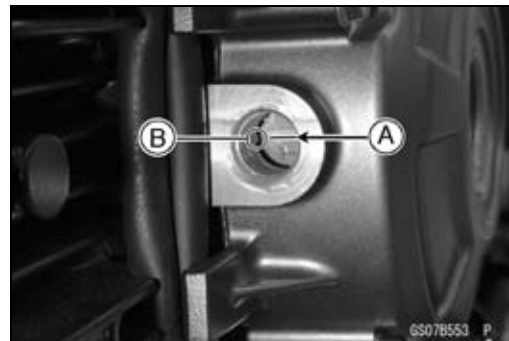

- Using a thickness gauge [A], measure the valve clearance between the adjusting screw and the valve stem.
- Measure the both valves at a time.
- ★If the valve clearance is incorrect, adjust it.

#### Valve Clearance

##### Standard:

Exhaust	0.08 ~ 0.12 mm (0.0031 ~ 0.0047 in.)
Intake	0.04 ~ 0.08 mm (0.0016 ~ 0.0031 in.)

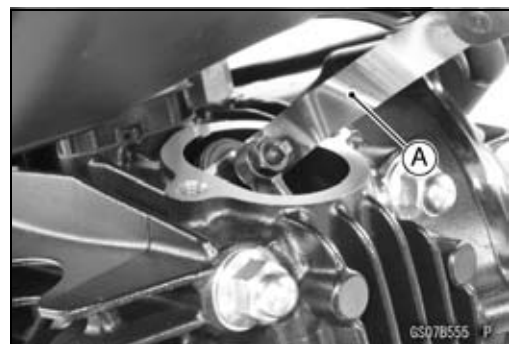

## Periodic Maintenance Procedures

### Valve Clearance Adjustment

- Remove:
  - Air Cleaner Housing (see Air Cleaner Housing Removal in the Fuel System (DFI) chapter)
- Use the valve adjusting screw holder [A] to holding the valve adjusting screw [B], loosen the adjusting screw locknut [C] and insert the thickness gauge [D] between the valve and adjusting screw, and turn the screw until the adjusting screw stops.

**Special Tool - Valve Adjusting Screw Holder: 57001-1217**

- Tighten the locknut, and install the removed parts.
- Replace the O-rings with new ones.

**Torque - Valve Adjusting Screw Locknuts: 8.8 N·m (0.90 kgf·m, 78 in·lb)**

**Valve Adjusting Cap Bolts: 5.2 N·m (0.53 kgf·m, 46 in·lb)**

- Install the removed parts (see appropriate chapters).

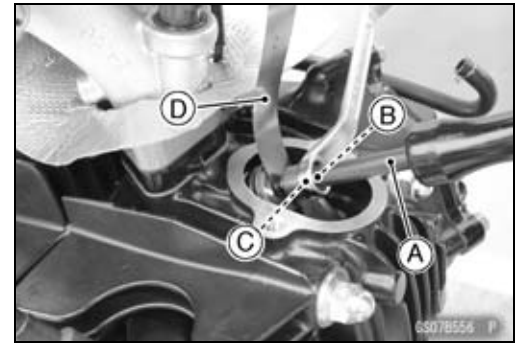

### Clutch

#### Clutch Release Adjustment (BR125G only)

- Loosen the clutch adjusting screw locknut with a wrench [A].
- Loosen the adjusting screw [B] counterclockwise until it becomes hard to turn.
- Tighten the adjusting screw until the specified value.

#### Clutch Release

**Standard: 1/4 turn out**

- Tighten the locknut without changing the adjusting screw position.

**Torque - Clutch Adjusting Screw Locknut: 19 N·m (1.9 kgf·m, 14 ft·lb)**

- Start the engine and inspect the conditions of engine shifting the pedal a few times.

#### Clutch Operation Inspection (BR125H/J)

- Pull the clutch lever just enough to take up the free play [A].
- Measure the gap between the lever and the lever holder.

#### Clutch Lever Free Play

**Standard: 2 ~ 3 mm (0.08 ~ 0.12 in.)**

- ★ If the gap is too wide, the clutch may not release fully. If the gap is too narrow, the clutch may not engage fully. In either case, adjust it.

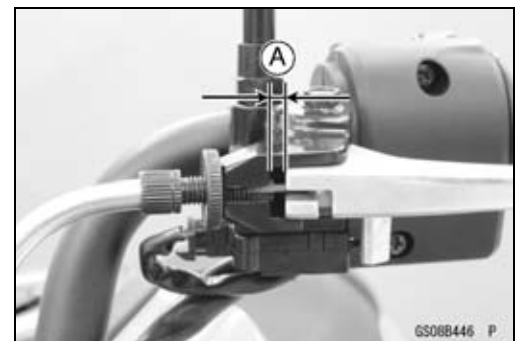
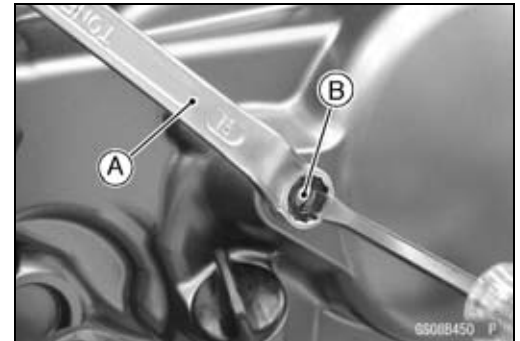

## 2-20 PERIODIC MAINTENANCE

### Periodic Maintenance Procedures

#### **⚠ WARNING**

The engine and exhaust system get extremely hot during normal operation and can cause serious burns. Never touch the engine or exhaust pipe during clutch adjustment.

- Loosen the locknut [A].
- Turn the adjuster [B] so that the lever play is correct.

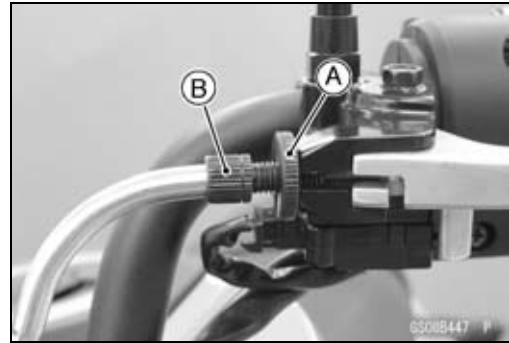

- Slide the dust cover [A].
- Loosen the rear locknut [B].
- Turn the front locknut [C] at the clutch cable until the free play is correct.

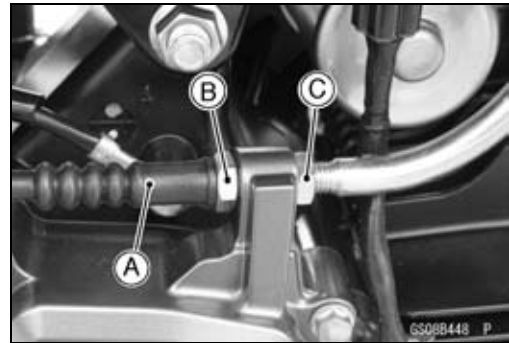

#### **⚠ WARNING**

Too much cable play can prevent clutch disengagement and cause an accident resulting in serious injury or death. When adjusting the clutch or replacing the cable, be sure the upper end of the clutch outer cable is fully seated in its fitting, or it could slip into place later, creating enough cable play to prevent clutch disengagement.

- Tighten the rear locknut.
- After the adjustment, start the engine and check that the clutch does not slip and that it releases properly.

## Engine Lubrication System

### **Engine Oil Change**

- Support the motorcycle perpendicular to the ground.
- Warm up the engine thoroughly so that the oil will pick up any sediment and drain easily. Then stop the engine.
- Place an oil pan beneath the engine.
- Remove the engine oil drain bolt [A] to drain the oil.
- The oil in the oil filter can be drained by removing the filter.



- Replace the drain bolt gasket with a new one.
- Tighten:

**Torque - Engine Oil Drain Bolt: 29 N·m (3.0 kgf·m, 21 ft·lb)**

- Remove the oil filler cap/dipstick [A].
- Pour in the specified type and amount of oil.

#### **Recommended Engine Oil**

**Type:** API SG, SH, SJ, SL or SM with JASO MA, MA1 or MA2

**Viscosity:** SAE10W-40

**Capacity:** 0.8 L (0.8 US qt) (When filter is not removed)  
0.9 L (1.0 US qt) (When filter is removed)  
1.0 L (1.1 US qt) (When engine is completely dry)



Periodic Maintenance Procedures

**NOTE**

- Do not add any chemical additive to the oil. Oils fulfilling the above requirements are fully formulated and provide adequate lubrication for both the engine and the clutch.
- Although 10W-40 engine oil is the recommended oil for most conditions, the oil viscosity may need to be changed to accommodate atmospheric conditions in your riding area.

- Replace the O-ring with a new one.
- Apply grease to the new O-ring.
- Install the oil filler cap/dipstick.
- Check the oil level (see Oil Level Inspection in the Engine Lubrication System chapter).

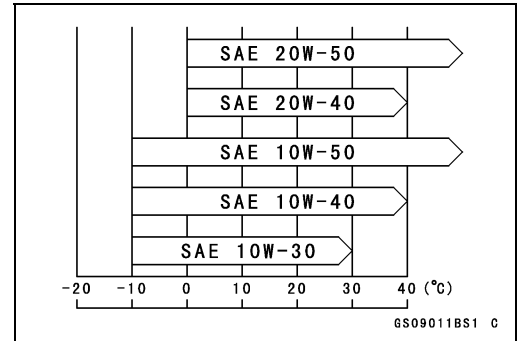

**Oil Filter Replacement**

- Remove the lower fairing (see Lower Fairing Removal in the Frame chapter).
- Drain the engine oil (see Engine Oil Change).
- Remove the oil filter cap bolts [A] and oil filter cap [B].

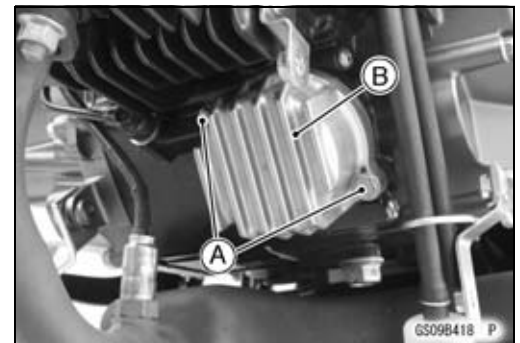

- Replace the filter element [A] with a new one.
- Set the spring [B] into the oil filter cap.

**NOTE**

- Install the filter element so that the seal side [C] facing to the engine.

- Apply grease to the new O-ring [D].
- Fit the O-ring onto the oil filter cap [E].
- Install the oil filter cap.
- Tighten:

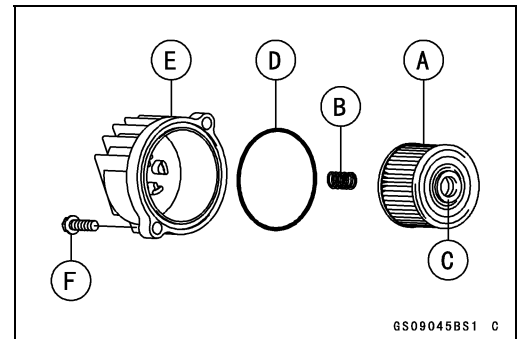

**Torque - Oil Filter Cap Bolts [F]: 5.2 N·m (0.53 kgf·m, 46 in·lb)**

- Install the lower fairing (see Lower Fairing Installation in the Frame chapter).
- Pour in the specified engine oil (see Engine Oil Change in the Periodic Maintenance chapter).

**Wheels/Tires**

**Air Pressure Inspection**

- Remove the air valve cap.
- Measure the tire air pressure with an air pressure gauge [A] when the tires are cold (that is, when the motorcycle has not been ridden more than a mile during the past 3 hours).
- ★ Adjust the tire air pressure according to the specifications if necessary.

**Air Pressure (when Cold)**

**Front: 150 kPa (1.50 kgf/cm<sup>2</sup>, 22 psi)**

**Rear: 200 kPa (2.00 kgf/cm<sup>2</sup>, 29 psi)**

- Install the air valve cap.

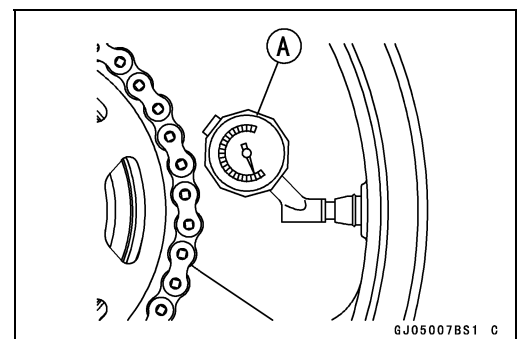

## 2-22 PERIODIC MAINTENANCE

### Periodic Maintenance Procedures

#### Wheels and Tires Inspection

##### Wheel/Tire Damage Inspection

- Remove any imbedded stones [A] or other foreign particles [B] from tread.
  - Visually inspect the tire for cracks and cuts, and replace the tire if necessary. Swelling or high spots indicate internal damage, requiring tire replacement.
  - Visually inspect the wheel for cracks, cuts and dents damage.
- ★ If any damage is found, replace the wheel if necessary.

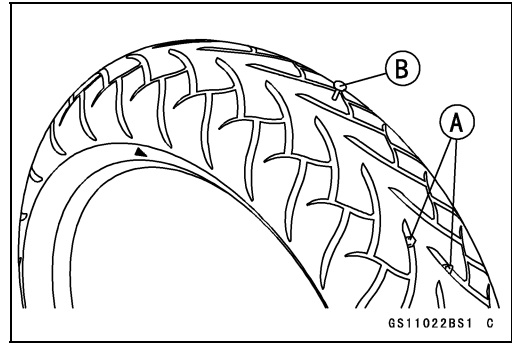

##### Tire Tread Wear Inspection

As the tire tread wears down, the tire becomes more susceptible to puncture and failure. An accepted estimate is that 90% of all tire failures occur during the last 10% of tread life (90% worn). So it is false economy and unsafe to use the tires until they are bald.

- Measure the tread depth at the center of the tread with a depth gauge [A]. Since the tire may wear unevenly, take measurement at several places.
- ★ If any measurement is less than the service limit, replace the tire (see Tire Removal/Installation in the Wheels/Tires chapter).

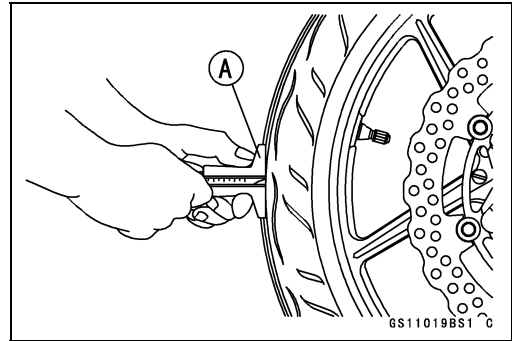

##### Tread Depth

###### Standard:

Front 4.2 mm (0.17 in.)

Rear 4.7 mm (0.19 in.)

###### Service Limit:

Front 1 mm (0.04 in.)

Rear 2 mm (0.08 in.) (Up to 130 km/h (80 mph))

3 mm (0.12 in.) (Over 130 km/h (80 mph))

#### **⚠ WARNING**

Some replacement tires may adversely affect handling and cause an accident resulting in serious injury or death. To ensure proper handling and stability, use only the recommended standard tires for replacement, inflated to the standard pressure.

#### **NOTE**

- Most countries may have their own regulations a minimum tire tread depth: be sure to follow them.
- Check and balance the wheel when a tire is replaced with a new one.

**Periodic Maintenance Procedures**

**Wheel Bearing Damage Inspection**

- Raise the front wheel off the ground with the jack (see Front Wheel Removal in the Wheels/Tires chapter).
  - Turn the handlebars all the way to the right or left.
  - Inspect the roughness of the front wheel bearing by pushing and pulling [A] the wheel.
  - Spin [B] the front wheel lightly, and check for smoothly turn, roughness, binding or noise.
  - ★ If roughness, binding or noise is found, remove the front wheel and inspect the wheel bearing (see Front Wheel Removal, Hub Bearing Inspection in the Wheels/Tires chapter).
- 
- Raise the rear wheel off the ground with the stand (see Rear Wheel Removal in the Wheels/Tires chapter).
  - Inspect the roughness of the rear wheel bearing by pushing and pulling [A] the wheel.
  - Spin [B] the rear wheel lightly, and check for smoothly turn, roughness, binding or noise.
  - ★ If roughness, binding or noise is found, remove the rear wheel and inspect the wheel bearing (see Rear Wheel Removal, Hub Bearing Inspection in the Wheels/Tires chapter).

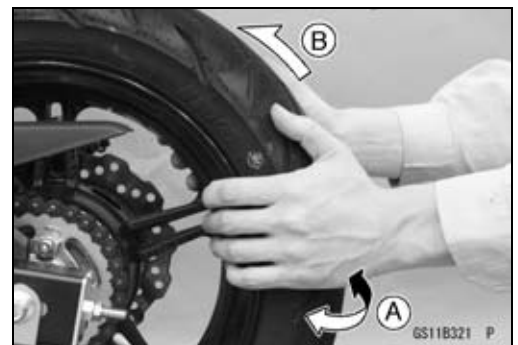
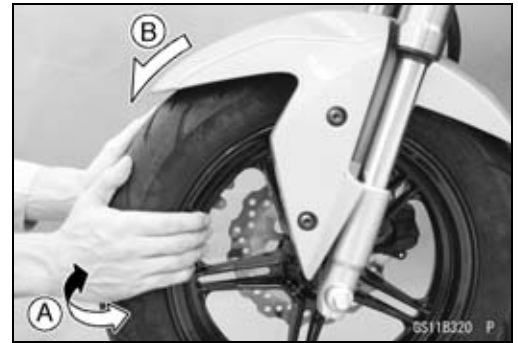

**Final Drive**

**Drive Chain Lubrication Condition Inspection**

Lubrication is necessary after riding through rain or on wet roads, or any time that the chain appears dry.

If the chain is especially dirty, clean it using a cleaner for chains following the instructions supplied by the chain cleaner manufacturer.

- Apply lubricant to the sides of the rollers so that it will penetrate to the rollers and bushings. Wipe off any excess lubricant.
- Oil Applied Areas [A]
- Wipe off any lubricant that gets on the tire surface.

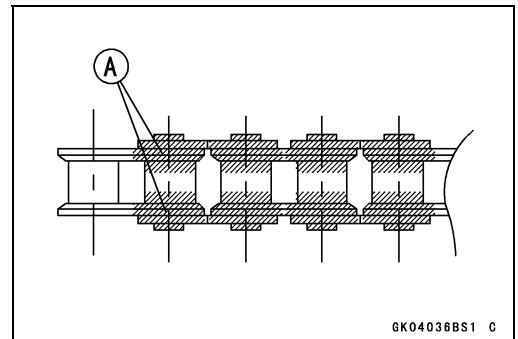

**Drive Chain Slack Inspection**

**NOTE**

- Check the slack with the motorcycle setting on its side stand.
- Clean the chain if it is dirty, and lubricate it if it appears dry.
- Check the wheel alignment (see Wheel Alignment Inspection).
- Rotate the rear wheel to find the position where the chain is tightest.
- Measure the vertical movement (chain slack) [A] midway between the sprockets.
- ★ If the chain slack exceeds the standard, adjust it.

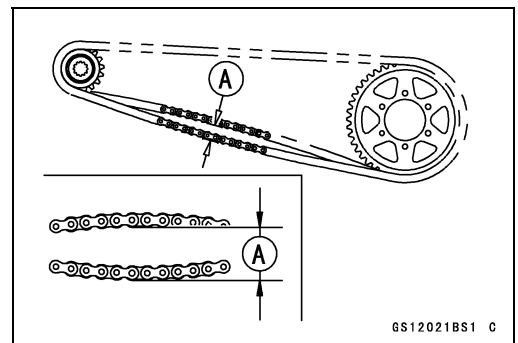

**Chain Slack**

Standard: 20 ~ 35 mm (0.8 ~ 1.4 in.)

## 2-24 PERIODIC MAINTENANCE

### Periodic Maintenance Procedures

#### Drive Chain Slack Adjustment

- Remove the cotter pin [A], and loosen the rear axle nut [B].
- Loosen the both chain adjuster locknuts [C].
- ★ If the chain is too loose, turn out the left and right chain adjusters [D] evenly.
- ★ If the chain is too tight, turn in the left and right chain adjusters evenly, and kick the wheel forward.
- Turn both chain adjusters evenly until the drive chain has the correct amount of slack. To keep the chain and wheel properly aligned, the notch [E] on the right wheel alignment indicator [F] should align with the same swingarm mark or position [G] that the left wheel alignment indicator notch aligns with.

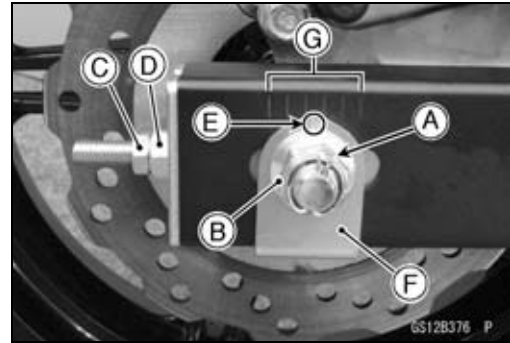

#### **⚠ WARNING**

**Misalignment of the wheel will result in abnormal wear and may result in an unsafe riding condition. Be sure the wheel is properly aligned.**

- Tighten both chain adjuster locknuts securely.
- Tighten:  
Torque - Rear Axle Nut [A]: 64 N·m (6.5 kgf·m, 47 ft·lb)
- Turn the wheel, measure the chain slack again at the tightest position, and readjust if necessary.
- Replace the cotter pin [B] with a new one.
- Insert the cotter pin and bend the pin ends [C].

#### **⚠ WARNING**

**A loose axle nut can lead to an accident resulting in serious injury or death. Tighten the axle nut to the proper torque and install a new cotter pin.**

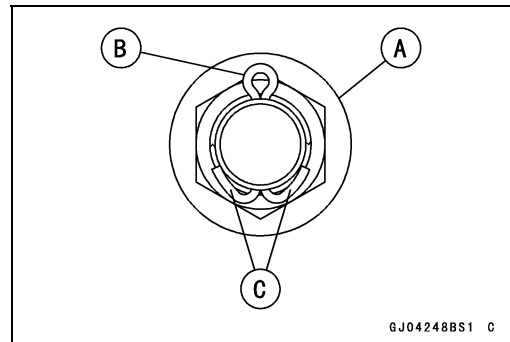

#### Wheel Alignment Inspection

- Check that the notch [A] on the left wheel alignment indicator [B] aligns with the same swingarm mark or position [C] that the right wheel alignment indicator notch aligns with.
- ★ If they do not, adjust the chain slack and align the wheel alignment (see Drive Chain Slack Adjustment).

#### **NOTE**

○ Wheel alignment can be also checked using the straightedge or string method.

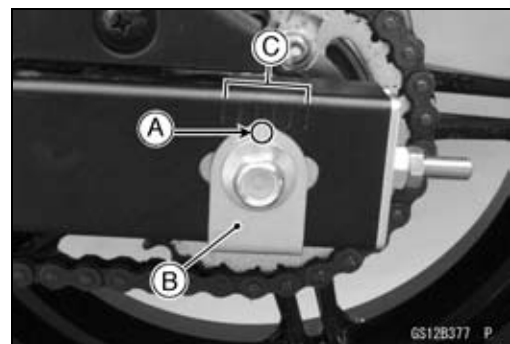

#### **⚠ WARNING**

**Misalignment of the wheel will result in abnormal wear and may result in an unsafe riding condition. Be sure the wheel is properly aligned.**



**Periodic Maintenance Procedures**

**Drive Chain Wear Inspection**

- Remove the mud guard (see Mud Guard Removal in the Frame chapter).
- Rotate the rear wheel to inspect the drive chain for damaged rollers, and loose pins and links.
- ★ If there is any irregularity, replace the drive chain.
- ★ Lubricate the drive chain if it appears dry.
- Stretch the chain taut by hanging a 10 kg (22 lb) weight [A] on the chain.
- Measure the length of 20 links [B] on the straight part [C] of the chain from the pin center of the 1st pin to the pin center of the 21st pin. Since the chain may wear unevenly, take measurements at several places.
- ★ If any measurements exceed the service limit, replace the chain. Also, replace the front and rear sprockets when the drive chain is replaced.

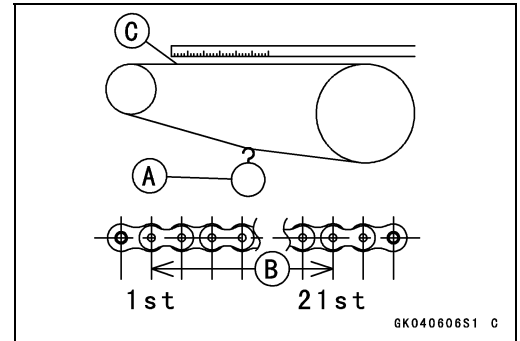

**Drive Chain 20-link Length**

**Standard:** 254.0 ~ 254.6 mm (10.00 ~ 10.02 in.)

**Service Limit:** 259 mm (10.2 in.)

**⚠ WARNING**

A chain that breaks or jumps off the sprockets could snag on the engine sprocket or lock the rear wheel, severely damaging the motorcycle and causing it to go out of control. Inspect the chain for damage and proper adjustment before each ride. If chain wear exceeds the service limit, replace it with the standard chain. It is an endless type and should not be cut for installation.

**Standard Chain**

**Make:** DAIDO

**Type:** DID420AD

**Link:** 100 links

**Chain Guide Wear Inspection**

- Remove the left side/frame cover (see Side/Frame Cover Removal in the Frame chapter).
- Visually inspect the chain guide [A].
- ★ Replace the chain guide if it shows any signs of abnormal wear or damage.
- To remove the chain guide, remove the swingarm (see Swingarm Removal in the Suspension chapter).

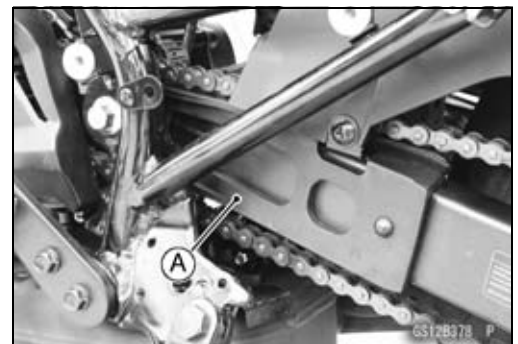

## 2-26 PERIODIC MAINTENANCE

### Periodic Maintenance Procedures

#### Brakes

##### *Brake System Inspection*

##### Brake Fluid Leak Inspection

- Remove:
  - Mud Guard (see Mud Guard Removal in the Frame chapter)
  - Right Side/Frame Cover (see Side/Frame Cover Removal in the Frame chapter)
- Apply the brake lever or pedal and inspect the brake fluid leak from the brake hoses [A] and fittings [B].
- ★ If the brake fluid leaked from any position, inspect or replace the problem part.

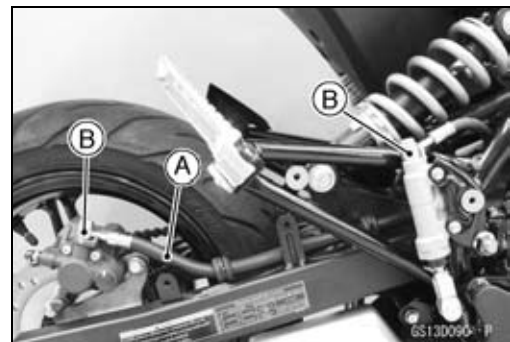
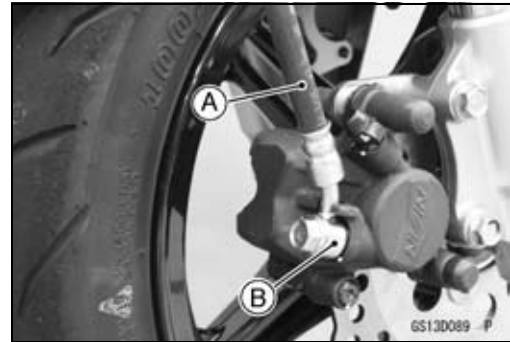
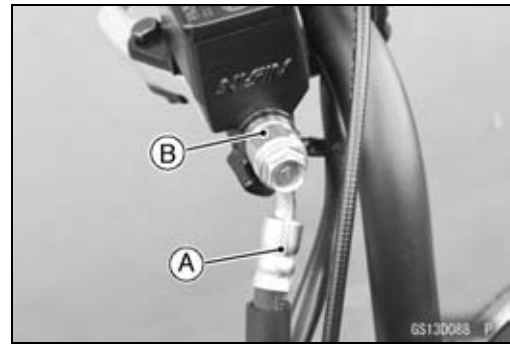

##### Brake Hose Damage and Installation Condition Inspection

- Remove:
  - Mud Guard (see Mud Guard Removal in the Frame chapter)
  - Right Side/Frame Cover (see Side/Frame Cover Removal in the Frame chapter)
- Inspect the brake hoses and fittings for deterioration, cracks and signs of leakage.
- The high pressure inside the brake line can cause fluid to leak [A] or the hose to burst if the line is not properly maintained. Bend and twist the rubber hose while examining it.
- ★ Replace the hose if any crack [B], bulge [C] or leakage is noticed.
- ★ Tighten any brake hose banjo bolts.
  - Torque - Brake Hose Banjo Bolts: 25 N·m (2.5 kgf·m, 18 ft·lb)**
- Inspect the brake hose routing.
- ★ If any brake hose routing is incorrect, run the brake hose according to Cable, Wire, and Hose Routing section in the Appendix chapter.

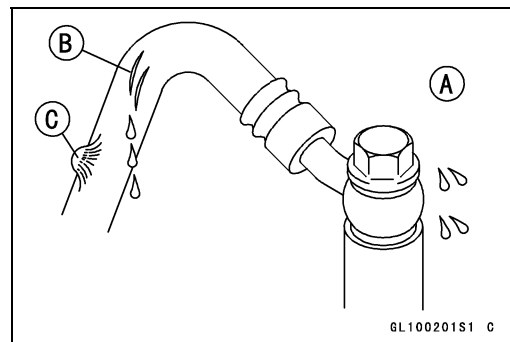

**Periodic Maintenance Procedures**

**Brake Operation Inspection**

- Inspect the operation of the front and rear brake by running the vehicle on the dry road.
- ★ If the brake operation is insufficiency, inspect the brake system.

**⚠ WARNING**

**When test riding the vehicle, be aware of surrounding traffic for your safety.**

**Brake Fluid Level Inspection**

- Check that the brake fluid level in the front brake reservoir [A] is above the lower level line [B].

**NOTE**

○ Hold the reservoir horizontal by turning the handlebars when checking brake fluid level.

**NOTICE**

**Brake fluid quickly damages painted plastic surfaces; any spilled fluid should be completely washed away immediately.**

- ★ If the fluid level is lower than the lower level line, remove the screws, reservoir cap, diaphragm plate and diaphragm. Fill the reservoir to the upper level line [C].
- Install the diaphragm, diaphragm plate and reservoir cap.
- Tighten:

**Torque - Front Brake Reservoir Cap Screws: 1.5 N·m (0.15 kgf·m, 13 in·lb)**

- Remove the right side/frame cover (see Side/Frame Cover Removal in the Frame chapter).
- Check that the brake fluid level in the rear brake reservoir [A] is above the lower level line [B].
- ★ If the fluid level is lower than the lower level line, fill the reservoir to the upper level line [C].

**⚠ WARNING**

**Mixing brands and types of brake fluid can reduce the brake system's effectiveness and cause an accident resulting in injury or death. Do not mix two brands of brake fluid. Change the brake fluid in the brake line completely if the brake fluid must be refilled but the type and brand of the brake fluid that is already in the reservoir are unidentified.**

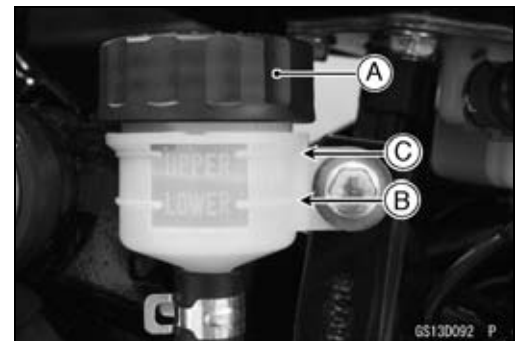
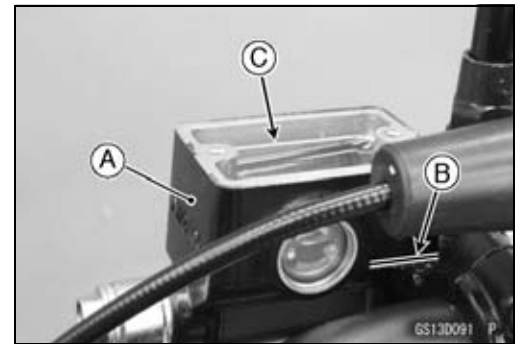

**Recommended Disc Brake Fluid**

**Grade:**

Front	DOT3 or DOT4
Rear	DOT3

## 2-28 PERIODIC MAINTENANCE

### Periodic Maintenance Procedures

- Add the brake fluid according to the following procedures.

- Remove:

- Reservoir Cap Mounting Bolt [A]
- Reservoir Cap [B]
- Diaphragm Plate
- Diaphragm

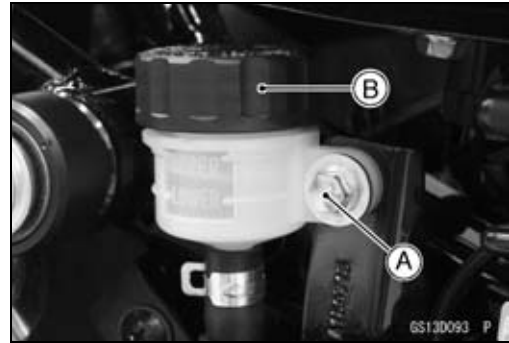

- Fill the reservoir with specified brake fluid to the upper level line [A].

- Install the diaphragm and diaphragm plate.



- Follow the procedure below to install the rear brake fluid reservoir cap correctly.

○First, tighten the rear brake fluid reservoir cap [A] clockwise [B] by hand until slight resistance is felt indicating that the cap is seated on the reservoir body [C], then tighten the cap an additional 1/6 turn [D] while holding the brake fluid reservoir body.

- Tighten the reservoir cap mounting bolt.

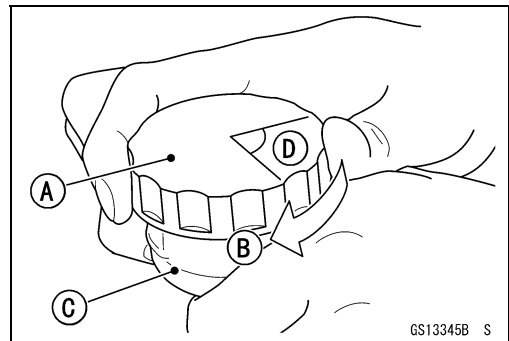

### Brake Fluid Change

#### NOTE

○The procedure to change the front brake fluid is as follows. Changing the rear brake fluid is the same as for the front brake.

- Level the brake fluid reservoir.
- Remove the screws, reservoir cap, diaphragm plate and diaphragm.
- Remove the rubber cap [A] from the bleed valve on the caliper.
- Attach a clear plastic hose [B] to the bleed valve, and run the other end of the hose into a container.
- Fill the reservoir with fresh specified brake fluid.

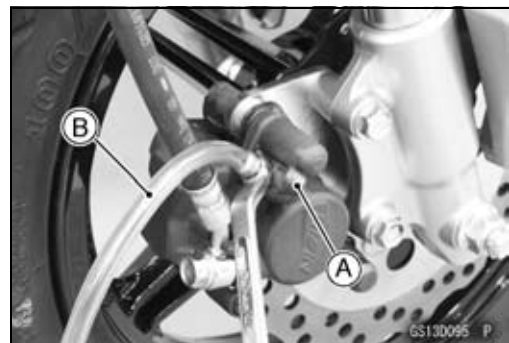

**Periodic Maintenance Procedures**

- Change the brake fluid.
- Repeat this operation until fresh brake fluid comes out from the plastic hose or the color of the fluid changes.
  1. Open the bleed valve [A].
  2. Apply the brake and hold it [B].
  3. Close the bleed valve [C].
  4. Release the brake [D].

**NOTE**

○ *The fluid level must be checked often during the changing operation and replenished with fresh brake fluid. If the fluid in the reservoir runs out any time during the changing operation, the brakes will need to be bled since air will have entered the brake line.*

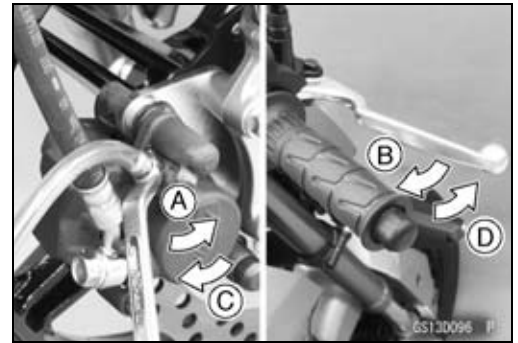

- Remove the clear plastic hose.
- Install the diaphragm, diaphragm plate and reservoir cap.
- Tighten:

**Torque - Front Brake Reservoir Cap Screws: 1.5 N·m (0.15 kgf·m, 13 in·lb)**

- Follow the procedure below to install the rear brake fluid reservoir cap correctly.
- First, tighten the rear brake fluid reservoir cap [A] clockwise [B] by hand until slight resistance is felt indicating that the cap is seated on the reservoir body [C], then tighten the cap an additional 1/6 turn [D] while holding the brake fluid reservoir body.

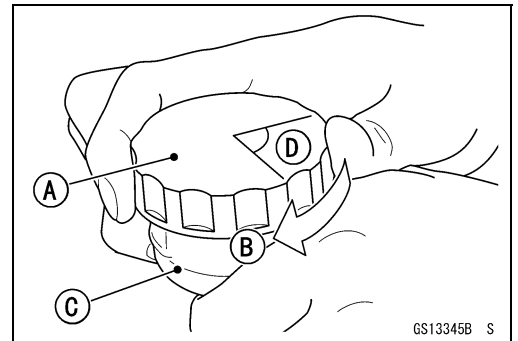

- Tighten the bleed valve, and install the rubber cap.

**Torque - Bleed Valve: 7.8 N·m (0.80 kgf·m, 69 in·lb)**

- After changing the fluid, check the brake for good braking power, no brake drag, and no fluid leakage.
- ★ If necessary, bleed the air from the lines.

## 2-30 PERIODIC MAINTENANCE

### Periodic Maintenance Procedures

#### Brake Hose Replacement

##### NOTICE

Brake fluid quickly damages painted plastic surfaces; any spilled fluid should be completely washed away immediately.

- Remove:
  - Headlight Unit (see Headlight Unit Removal in the Electrical System chapter)
  - Right Side/Frame Cover (see Side/Frame Cover Removal in the Frame chapter)
  - Mud Guard (see Mud Guard Removal in the Frame chapter)
  - Brake Hose Banjo Bolts [A]
- Clear the brake hoses [B] from the clamps [C].
- When removing the brake hoses, note the following.
  - Take care not to spill the brake fluid on the painted or plastic parts.
  - Temporarily secure the end of the brake hose to some high place to keep fluid loss to a minimum.
  - Immediately wash away any brake fluid that spills.
- When installing the brake hoses, note the following.
  - Avoid sharp bending, kinking, flattening or twisting, and run the hoses according to Cable, Wire, and Hose Routing section in the Appendix chapter.
  - There are washers on each side of the brake hose fitting. Replace them with new ones.
- Tighten:
  - Torque - Brake Hose Banjo Bolts: 25 N·m (2.5 kgf·m, 18 ft·lb)**
- Fill the brake line after installing the brake hose (see Brake Fluid Change).

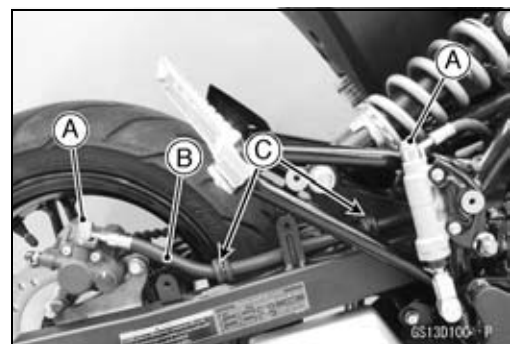
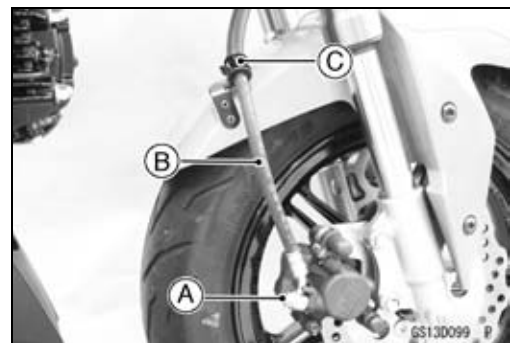
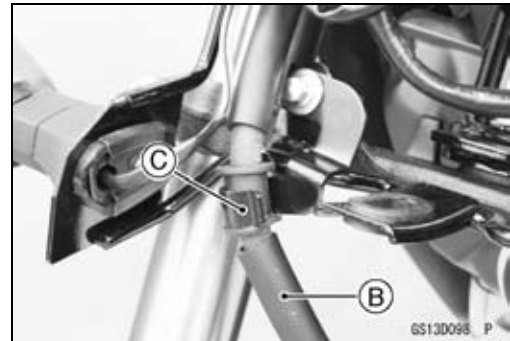

Periodic Maintenance Procedures

**Master Cylinder Rubber Parts Replacement**

**Front Master Cylinder Disassembly**

- Remove the front master cylinder (see Front Master Cylinder Removal in the Brakes chapter).
- Remove:
  - Front Brake Reservoir Cap Screws [A]
  - Reservoir Cap [B]
  - Diaphragm [C]
- Unscrew the locknut [D] and pivot bolt [E], and remove the brake lever.
- Pull the dust cover [F] out of place, and remove the circlip [G].
- **Special Tool - Inside Circlip Pliers: 57001-143**
- Remove the washer [H] and piston assembly [I].

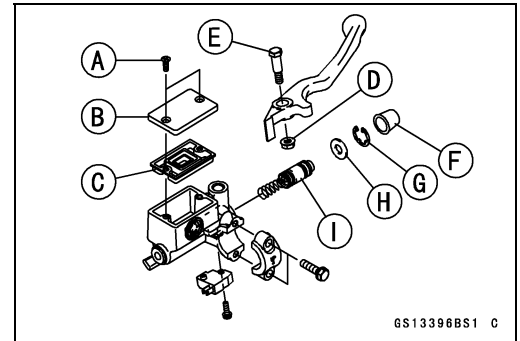

**NOTICE**

**Do not remove the secondary cup from the piston since removal will damage it.**

- Replace:
  - Diaphragm [C]
  - Dust Cover [F]
  - Circlip [G]
  - Piston Assembly [I]

**Rear Master Cylinder Disassembly**

- Remove the rear master cylinder (see Rear Master Cylinder Removal in the Brakes chapter).
- Remove the circlip [A], connector [B] and O-ring [C].
- **Special Tool - Inside Circlip Pliers: 57001-143**
- Slide the dust cover [D] out of place, and remove the circlip [E].
- **Special Tool - Inside Circlip Pliers: 57001-143**
- Pull out the push rod assembly [F].
- Remove the piston assembly [G].

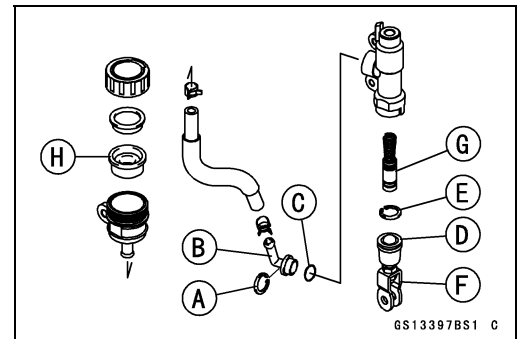

**NOTICE**

**Do not remove the secondary cup from the piston since removal will damage it.**

- Replace:
  - Circlip [A]
  - O-ring [C]
  - Circlip [E]
  - Push Rod Assembly [F]
  - Piston Assembly [G]
  - Diaphragm [H]

## 2-32 PERIODIC MAINTENANCE

### Periodic Maintenance Procedures

#### Master Cylinder Assembly

- Before assembly, clean all parts including the master cylinder with brake fluid or alcohol.

#### **NOTICE**

**Except for the disc pads and disc, use only disc brake fluid, isopropyl alcohol, or ethyl alcohol for cleaning brake parts. Do not use any other fluid for cleaning these parts. Gasoline, engine oil, or any other petroleum distillate will cause deterioration of the rubber parts. Oil spilled on any part will be difficult to wash off completely, and will eventually deteriorate the rubber used in the disc brake.**

- Apply brake fluid to the new parts and to the inner wall of the cylinder.
- Take care not to scratch the piston or the inner wall of the cylinder.
- Apply silicone grease to the followings.

Front: Brake Lever Pivot Bolt  
Contact Surface of Brake Lever and Piston

Rear: Dust Cover of Push Rod Assembly  
Contact Surface of Push Rod and Piston

- For the front master cylinder, tighten the brake lever pivot bolt, locknut and front brake reservoir cap screws.

**Torque - Brake Lever Pivot Bolt: 5.9 N·m (0.60 kgf·m, 52 in·lb)**

**Brake Lever Pivot Bolt Locknut: 5.9 N·m (0.60 kgf·m, 52 in·lb)**

**Front Brake Reservoir Cap Screws: 1.5 N·m (0.15 kgf·m, 13 in·lb)**

#### **Caliper Rubber Parts Replacement**

##### Front Caliper Disassembly

- Remove:
  - Front Caliper (see Front Caliper Removal in the Brakes chapter)
  - Brake Pads (see Brake Pad Removal in the Brakes chapter)
  - Pad Spring
- Using compressed air, remove the piston.
  - Cover the piston area with a clean heavy cloth [A].
  - Blow compressed air [B] into the hole for the banjo bolt to remove the piston.

#### **WARNING**

**The piston in the brake caliper can crush hands and fingers. Never place your hand or fingers in front of the piston.**

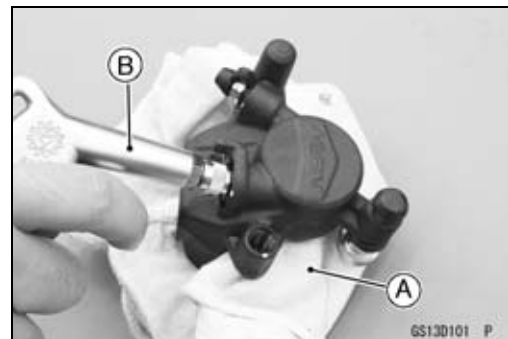



**Periodic Maintenance Procedures**

- Remove:
  - Caliper Holder [A]
  - Dust Seal [B]
  - Fluid Seal [C]
  - Bleed Valve [D]
  - Rubber Cap [E]
  - Friction Boot [F]
  - Dust Boot [G]

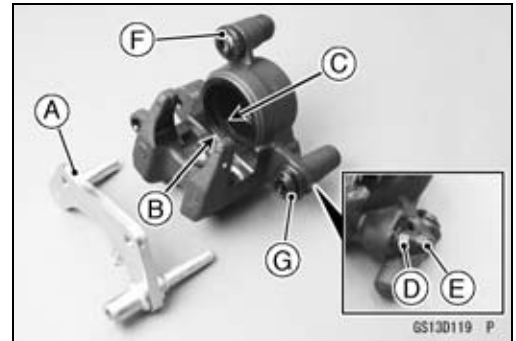

**Front Caliper Assembly**

- Clean the caliper parts except for the pads.

**NOTICE**

**For cleaning the parts, use only disc brake fluid, isopropyl alcohol, or ethyl alcohol.**

- Install the bleed valve and rubber cap.
- Tighten:
  - Torque - Bleed Valve: 7.8 N·m (0.80 kgf·m, 69 in·lb)**

- Replace the fluid seal [A] with a new one.
- Apply silicone grease to the fluid seals, and install them into the cylinders by hand.
- Replace the dust seal [B] with a new one.
- Apply silicone grease to the dust seals, and install them into the cylinders by hand.

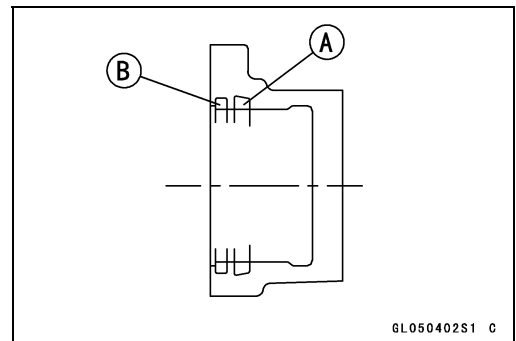

- Apply brake fluid to the outside of the pistons, and push them into each cylinder by hand.
- Check the friction boot [A] and the dust boot [B] replace them with new ones if they are damaged.
- Apply silicone grease to the caliper holder pin bolts [C].
- Install the caliper holder and pad spring.

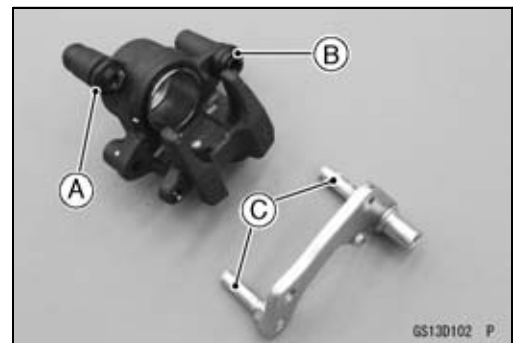

- Install the removed parts (see appropriate chapters).
- Wipe up any spilled brake fluid on the caliper with wet cloth.

## 2-34 PERIODIC MAINTENANCE

### Periodic Maintenance Procedures

#### Rear Caliper Disassembly

- Remove the rear caliper holder pin plug and loosen the rear caliper holder pin [A].
- Remove the banjo bolt [B] to disconnect the brake hose [C].
- Remove:
  - Rear Caliper Mounting Bolts [D]
  - Rear Caliper [E]
  - Rear Brake Pads (see Rear Brake Pad Removal in the Brake chapter)

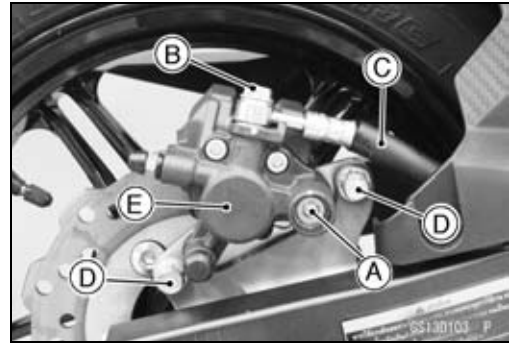

#### NOTICE

**Brake fluid quickly damages painted plastic surfaces; any spilled fluid should be completely washed away immediately.**

- Using compressed air, remove the piston.
- Cover the piston area with a clean heavy cloth [A].
- Blow compressed air [B] into the hole for the banjo bolt to remove the piston.

#### ⚠ WARNING

**The piston in the brake caliper can crush hands and fingers. Never place your hand or fingers in front of the piston.**

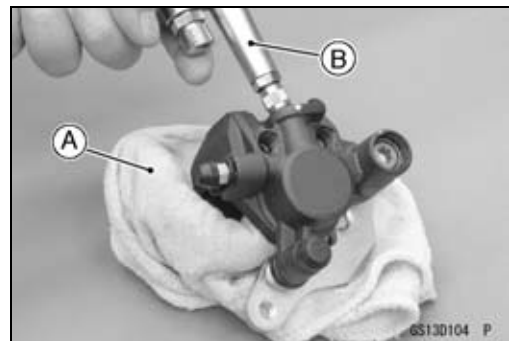

- Loosen the rear caliper holder pin [A] fully.
- Remove the caliper holder [B] and washer.

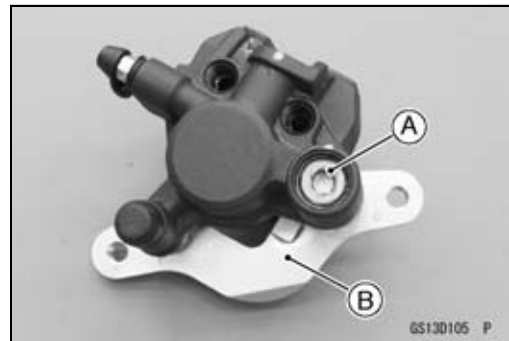

- Remove:
  - Dust Seal [A]
  - Fluid Seal [B]
  - Bleed Valve [C]
  - Rubber Cap [D]
  - Dust Boot [E]
  - Rear Caliper Holder Pin [F]
  - Friction Boot [G]

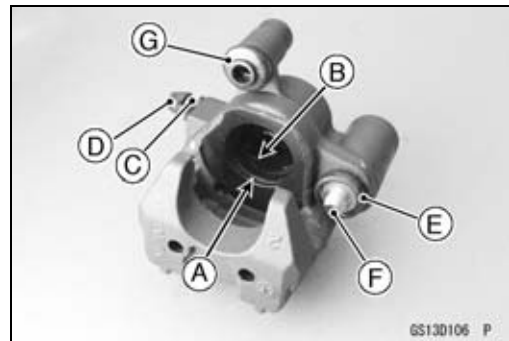

#### Rear Caliper Assembly

- Clean the caliper parts except for the pads.

#### NOTICE

**For cleaning of the parts, use only disc brake fluid, isopropyl alcohol, or ethyl alcohol.**

Periodic Maintenance Procedures

- Install the bleed valve [A] and rubber cap [B].
  - Torque - Bleed Valve: 7.8 N·m (0.80 kgf·m, 69 in·lb)**
- Replace the fluid seal [C] with a new one.
- Apply silicone grease to the fluid seal, and install it into the cylinder by hand.
- Replace the dust seal [D] with a new one.
- Apply silicone grease to the dust seal, and install it into the cylinder by hand.
- Replace the friction boot [E] and dust boot [F] if they are damaged.

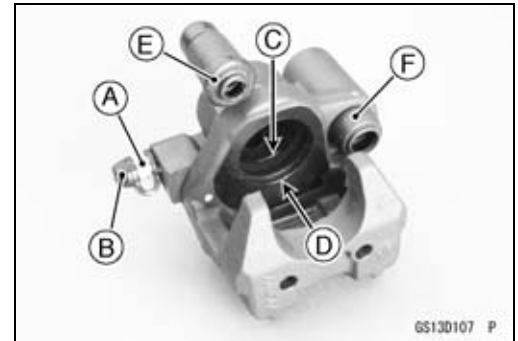

- Apply brake fluid to the outside of the piston, and push it into the cylinder by hand.
- Install the anti-rattle spring [A] in the caliper as shown.
- Apply silicone grease to the groove [B] on the rear caliper holder pin and install it.

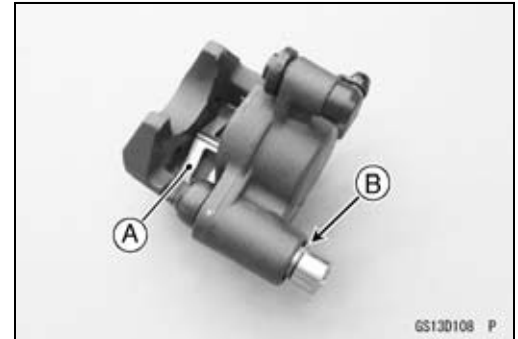

- Replace the washer [A] with a new one.
- Install the washer to the rear caliper holder pin so that the tapered side [B] faces caliper holder.  
Piston Side [C]

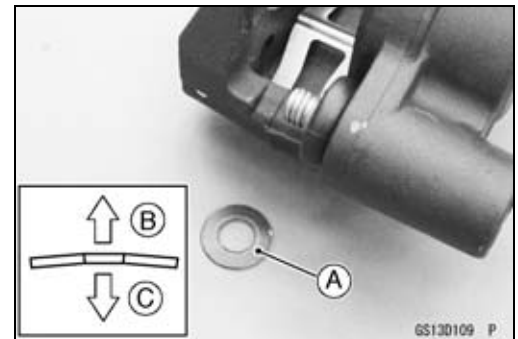

- Apply a silicone grease to the caliper holder shaft [A].
- Install the caliper holder [B].
- Tighten:
  - Torque - Rear Caliper Holder Pin: 17.2 N·m (1.75 kgf·m, 12.7 ft·lb)**

- Install the rear caliper holder pin plug.
- Install the pads (see Rear Brake Pad Installation in the Brakes chapter).
- Wipe up any spilled brake fluid on the caliper with wet cloth.
- Install the rear caliper (see Caliper Installation in the Brakes chapter).

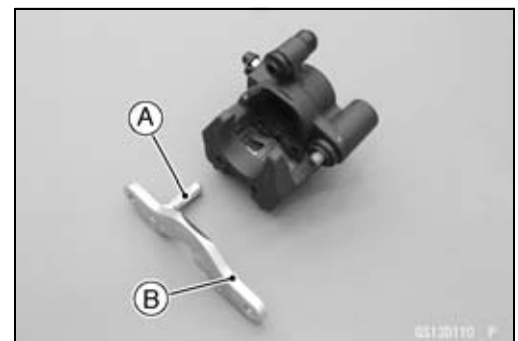

## 2-36 PERIODIC MAINTENANCE

### Periodic Maintenance Procedures

#### Brake Pad Wear Inspection

##### Front Brake Pad

- Remove the front brake pads (see Front Brake Pad Removal in the Brakes chapter).
- Check the lining thickness [A] of the pads in each caliper.
- ★ If the lining thickness of either pad is less than the service limit [B], replace both pads in the caliper as a set.

##### Pad Lining Thickness

Standard: 4.0 mm (0.16 in.)

Service Limit: 1 mm (0.04 in.)

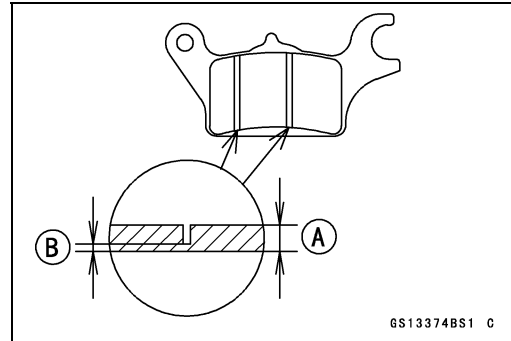

##### Rear Brake Pad

- Check the lining thickness [A] of the pads [B] in each caliper.
- ★ If the lining thickness of either pad is less than the service limit [C], replace both pads in the caliper as a set.

##### Brake Pad Lining Thickness

Standard: 4.5 mm (0.18 in.)

Service Limit: 1 mm (0.04 in.)

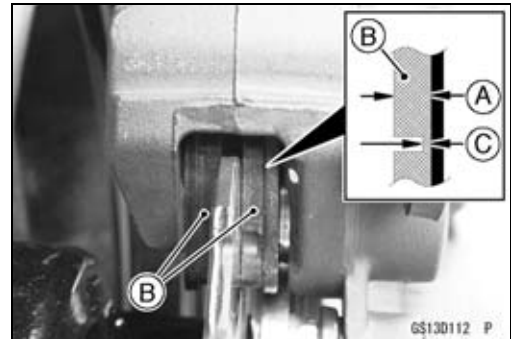

#### Brake Light Switch Operation Inspection

- Turn the ignition switch on.
- The brake light (LED) [A] should go on when the brake lever is applied or after the brake pedal is depressed about 10 mm (0.39 in.).

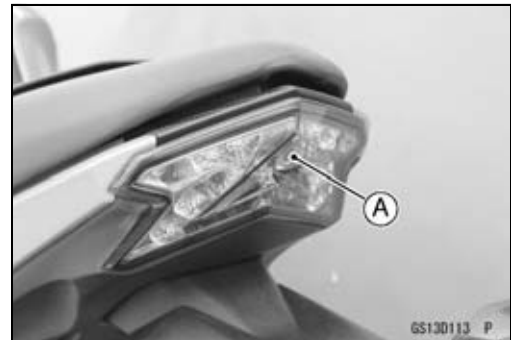

- ★ If it does not, adjust the brake light switch.
- Remove the right side/frame cover (see Side/Frame Cover Removal in the Frame chapter).
- While holding the switch body, turn the adjusting nut to adjust the switch.
  - Switch Body [A]
  - Adjusting Nut [B]
  - Light sooner as the body rises [C]
  - Light later as the body lowers [D]

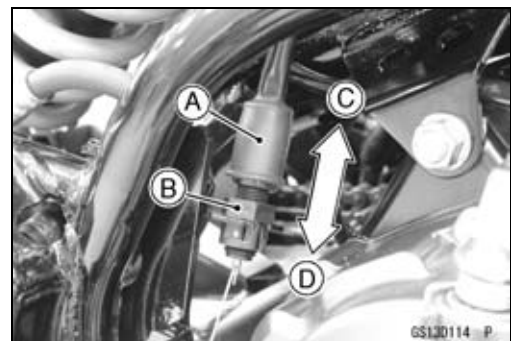

#### NOTICE

To avoid damaging the electrical connections inside the switch, be sure that the switch body does not turn during adjustment.

## Periodic Maintenance Procedures

- ★ If it does not go on, inspect or replace the following parts.
  - Battery (see Charging Condition Inspection in the Electrical System chapter)
  - Tail/Brake Light (LED) (see Tail/Brake Light (LED) Removal/Installation in the Electrical System chapter)
  - Battery Fuse 10 A and Headlight Fuse 10 A (see Fuse Inspection in the Electrical System chapter)
  - Front Brake Light Switch [A] (see Switch Inspection in the Electrical System chapter)
  - Rear Brake Light Switch (see Switch Inspection in the Electrical System chapter)
  - Harness (see Wiring Inspection in the Electrical System chapter)
- Install the right side/frame cover (see Side/Frame Cover Installation in the Frame chapter).



## Suspension

### Suspension System Inspection

#### Front Forks/Rear Shock Absorber Operation Inspection

- Pump the forks down and up [A] 4 or 5 times, and inspect the smooth stroke.
- ★ If the forks do not smoothly or noise is found, inspect the fork oil level or fork clamps (see Front Fork Oil Change in the Suspension chapter).
  
- Pump the seat down and up [A] 4 or 5 times, and inspect the smooth stroke.
- ★ If the shock absorber does not smoothly stroke or noise is found, inspect the oil leak (see Rear Shock Absorber Oil Leak Inspection).



#### Front Fork Oil Leak Inspection

- Visually inspect the front forks [A] for oil leakage.
- ★ Replace any defective parts, if necessary.



## 2-38 PERIODIC MAINTENANCE

### Periodic Maintenance Procedures

#### Rear Shock Absorber Oil Leak Inspection

- Visually inspect the rear shock absorber [A] for oil leakage.
- ★ If the oil leakage is found on it, replace the rear shock absorber with a new one.



#### Lubrication of Rear Suspension

##### Swingarm Pivot Lubrication

- Remove:
  - Swingarm (see Swingarm Removal in the Suspension chapter)
  - O-ring [A] (Both Sides)
- Replace the O-rings with new ones, and install them.
  
- Fill the grease [A] to the both side of the swingarm pivot.
  - O-ring [B]
  - Bushing [C]
  - Sleeve [D]
- Install the swingarm (see Swingarm Installation in the Suspension chapter).

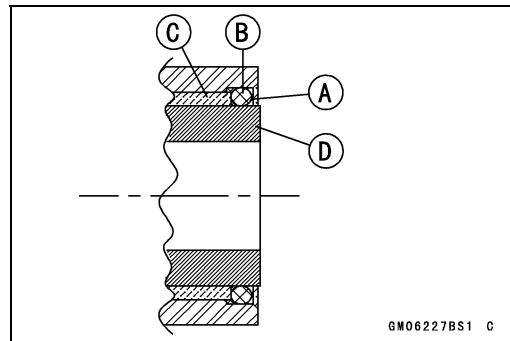
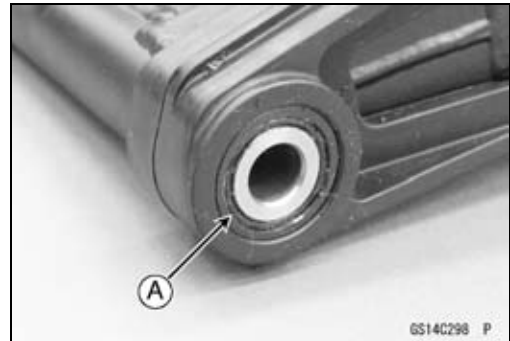

#### Steering

##### Steering Play Inspection

- Raise the front wheel off the ground with the jack (see Front Wheel Removal in the Wheels/Tires chapter).
- With the front wheel pointing straight ahead, alternately tap each end of the handlebars. The front wheel should swing fully left and right from the force of gravity until the fork hits the stop.
- ★ If the wheel binds or catches before the stop, the steering is too tight.
- Feel for steering looseness by pushing and pulling [A] the forks.
- ★ If you feel looseness, the steering is too loose.



#### NOTE

- The cables and wiring will have some effect on the motion of the fork which must be taken into account.
- Be sure the leads and cables are properly routed.
- The bearings must be in good condition and properly lubricated in order for any test to be valid.

**Periodic Maintenance Procedures**

**Steering Play Adjustment**

- Loosen:
  - Front Fork Clamp Bolt (Lower) [A] (Both Sides)



- Remove:
  - Handlebars (see Handlebar Removal in the Steering chapter)
  - Steering Stem Head Nut Plug [A]
- Loosen:
  - Steering Stem Head Nut [B]

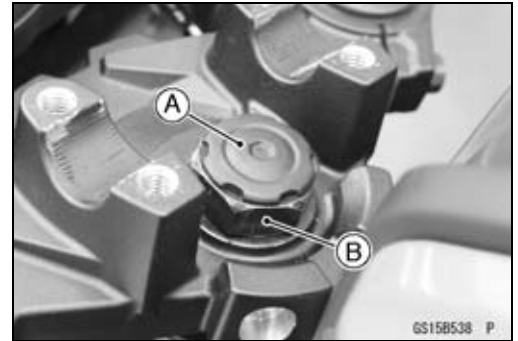

- Adjust the steering.
  - Special Tool - Steering Stem Nut Wrench [A]: 57001-1100**
  - ★ If the steering is too tight, loosen the stem nut a fraction of a turn.
  - ★ If the steering is too loose, tighten the stem nut a fraction of a turn.



**NOTE**

○ Turn the stem nut 1/8 turn at time maximum.

- Tighten:
  - Torque - Steering Stem Head Nut: 44 N·m (4.5 kgf·m, 32 ft·lb)**
  - Front Fork Clamp Bolts (Lower): 20 N·m (2.0 kgf·m, 15 ft·lb)**
- Check the steering again.
  - ★ If the steering is still too tight or too loose, repeat the adjustment.

**Steering Stem Bearing Lubrication**

- Remove the steering stem (see Steering Stem, Stem Bearing Removal in the Steering chapter).
- Wipe the old grease off the races and balls, washing them in a high flash-point solvent if necessary.
- ★ Replace the bearing part if they show wear or damage.
- ★ Apply grease liberally to the upper and lower races, and stick the bearing balls in place with grease. There are 23 steel balls [A] installed in the upper or lower outer races.
- ★ Install the steering stem (see Steering Stem, Stem Bearing Installation in the Steering chapter).
- ★ Adjust the steering (see Steering Play Adjustment).

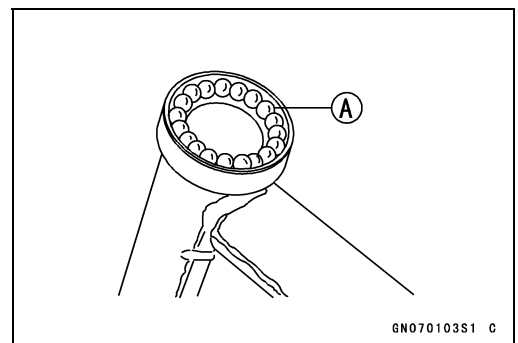

## 2-40 PERIODIC MAINTENANCE

### Periodic Maintenance Procedures

#### Electrical System

##### *Lights and Switches Operation Inspection*

###### First Step

- Set the gear position in the neutral position.
- Turn the ignition switch on.
- The following lights should go on according to below table.

City Light [A]	Goes on
Taillight (LED) [B]	Goes on
License Plate Light [C]	Goes on
Meter Panel LCD [D]	Goes on
Green Neutral Indicator Light (LED) [E]	Goes on
Yellow Engine Warning Light (LED) [F]	Goes on

- ★ If the light does not go on, inspect or replace the following parts.

Battery (see Charging Condition Inspection in the Electrical System chapter)

City Light Bulb (see City Light Bulb Replacement in the Electrical System chapter)

License Plate Light Bulb (see License Plate Light Bulb Replacement in the Electrical System chapter)

Tail/Brake Light (LED) (see Tail/Brake Light (LED) Removal/Installation in the Electrical System chapter)

Meter Panel LCD (see Meter Unit Inspection in the Electrical System chapter)

Green Neutral Indicator Light (LED) (see Meter Unit Inspection in the Electrical System chapter)

Yellow Engine Warning Light (LED) (see Meter Unit Inspection in the Electrical System chapter)

ECU (see ECU Power Supply Inspection in the Fuel System (DFI) chapter)

Battery Fuse 20 A, Ignition Fuse 10 A and Headlight Fuse 15 A (see Fuse Inspection in the Electrical System chapter)

Ignition Switch (see Switch Inspection in the Electrical System chapter)

Gear Position Switch (see Gear Position Switch Inspection in the Electrical System chapter)

Harness (see Wiring Inspection in the Electrical System chapter)

- Turn the ignition switch off.
- The all lights should go off.
- ★ If the light does not go off, replace the ignition switch.

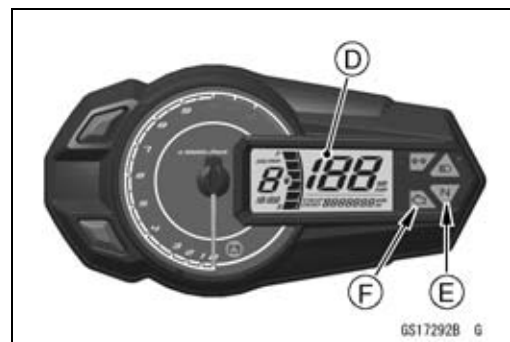
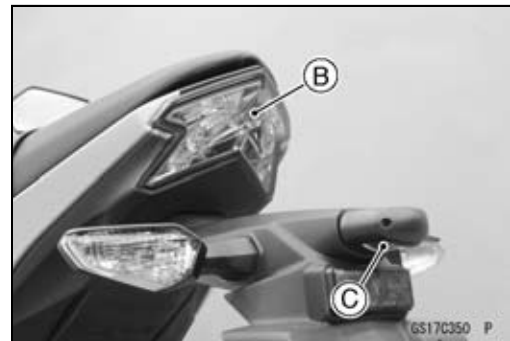



**Periodic Maintenance Procedures**

**Second Step**

- Turn the ignition switch on.
- Turn on the turn signal switch [A] (left or right position).
- The left or right turn signal lights [B] (front and rear) according to the switch position should blink.
- The green turn signal indicator light (LED) [C] in the meter unit should blink.
- ★ If each light does not blink, inspect or replace the following parts.

Turn Signal Light Bulb (see Turn Signal Light Bulb Replacement in the Electrical System chapter)

Green Turn Signal Indicator Light (LED) (see Meter Unit Inspection in the Electrical System chapter)

Turn Signal Switch (see Switch Inspection in the Electrical System chapter)

Meter Unit (see Meter Unit Inspection in the Electrical System chapter)

Harness (see Wiring Inspection in the Electrical System chapter)

- Push the turn signal switch.
- The turn signal lights and green turn signal indicator light (LED) should go off.
- ★ If the light does not go off, inspect or replace the following parts.

Turn Signal Switch (see Switch Inspection in the Electrical System chapter)

Meter Unit (see Meter Unit Inspection in the Electrical System chapter)

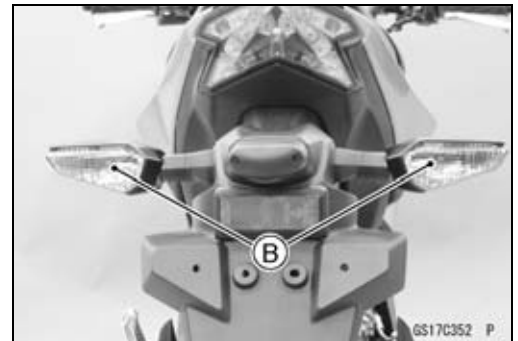
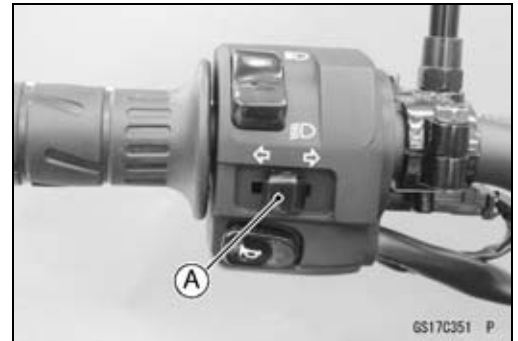

**Third Step**

- Set the dimmer switch [A] to low beam position.
- Start the engine.
- The low beam headlight should go on.
- ★ If the low beam headlight does not go on, inspect or replace the following parts.

Headlight Bulb (see Headlight Bulb Replacement in the Electrical System chapter)

Regulator Fuse 10 A (see Fuse Inspection in the Electrical System chapter)

Dimmer Switch (see Switch Inspection in the Electrical System chapter)

Harness (see Wiring Inspection in the Electrical System chapter)

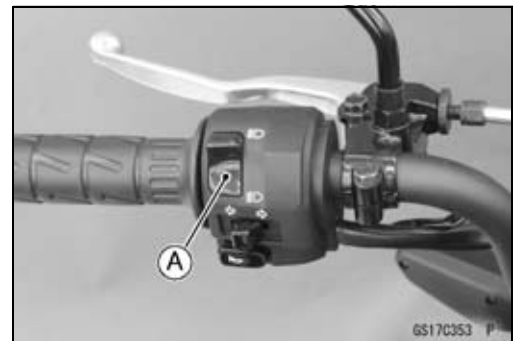

## 2-42 PERIODIC MAINTENANCE

### Periodic Maintenance Procedures

- Set the dimmer switch [A] to high beam position.
- Start the engine.
- The high beam headlight should go on.
- The blue high beam indicator light (LED) [B] should go on.
- ★ If the high beam headlight and/or blue high beam indicator light (LED) does not go on, inspect or replace the following parts.
  - Headlight Bulb (see Headlight Bulb Replacement in the Electrical System chapter)
  - Regulator Fuse 10 A (see Fuse Inspection in the Electrical System chapter)
  - Dimmer Switch (see Switch Inspection in the Electrical System chapter)
  - Harness (see Wiring Inspection in the Electrical System chapter)
- Turn the ignition switch off.
- The headlight and blue high beam indicator light (LED) should go off.



#### Headlight Aiming Inspection (BR125G/H)

- Inspect the headlight beam for aiming.
- Loosen the adjusting bolt [A].
- Adjust the headlight up or down.
- After adjusting the headlight beam, make sure to tighten the adjusting bolt securely.

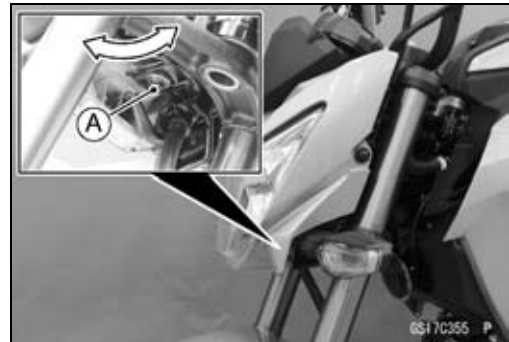

#### NOTE

○ On high beam, the brightest point should be slightly below horizontal with the motorcycle on its wheels and the rider seated. Adjust the headlight to the proper angle according to local regulations.



#### Headlight Aiming Inspection (BR125J)

- Inspect the headlight beam for aiming.
- ★ If the headlight beam points to one side rather than straight ahead, adjust the horizontal beam.

**Periodic Maintenance Procedures**

**Headlight Beam Horizontal Adjustment**

- Turn the horizontal adjuster [A] in both headlights in or out until the beam points straight ahead.
- ★ If the headlight beam points too low or high, adjust the vertical beam.

**Headlight Beam Vertical Adjustment**

- Turn the vertical adjuster [B] in both headlights in or out to adjust the headlight vertically.

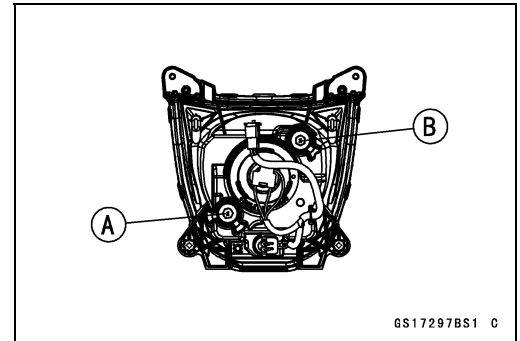

**NOTE**

- On high beam, the brightest points should be slightly below horizontal with the motorcycle on its wheels and the rider seated. Adjust the headlight to the proper angle according to local regulations.
- For the US model, the proper angle is 0.4 degrees below horizontal. This is 50 mm (2.0 in.) drop at 7.6 m (25 ft) measured from the center of the headlight with the motorcycle on its wheels and the rider seated.

- 50 mm (2.0 in.) [A]
- Center of Brightest Spot [B]
- 7.6 m (25 ft) [C]
- Height of Headlight Center [D]

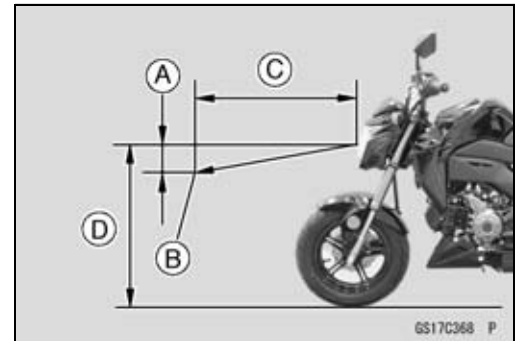

**Side Stand Switch Operation Inspection (BR125J)**

- Raise the rear wheel off the ground with the stand.
- Inspect the side stand switch operation accordance to below table.

**Side Stand Switch Operation**

Side Stand	Gear Position	Clutch Lever	Engine Start	Engine Run
Up	Neutral	Released	Starts	Continue running
Up	Neutral	Pulled in	Starts	Continue running
Up	In Gear	Released	Does not start	Continue running
Up	In Gear	Pulled in	Starts	Continue running
Down	Neutral	Released	Starts	Continue running
Down	Neutral	Pulled in	Starts	Continue running
Down	In Gear	Released	Does not start	Stops
Down	In Gear	Pulled in	Does not start	Stops

## 2-44 PERIODIC MAINTENANCE

### Periodic Maintenance Procedures

- ★ If the side stand switch operation does not work, inspect or replace the following parts.
  - Battery (see Charging Condition Inspection in the Electrical System chapter)
  - Battery Fuse 20 A (see Fuse Inspection in the Electrical System chapter)
  - Ignition Fuse 10 A (see Fuse Inspection in the Electrical System chapter)
  - Ignition Switch (see Switch Inspection in the Electrical System chapter)
  - Side Stand Switch (see Switch Inspection in the Electrical System chapter)
  - Engine Stop Switch (see Switch Inspection in the Electrical System chapter)
  - Gear Position Switch (see Gear Position Switch Inspection in the Electrical System chapter)
  - Starter Lockout Switch (see Switch Inspection in the Electrical System chapter)
  - Starter Relay (see Starter Relay Inspection in the Electrical System chapter)
  - Diode (2) (see Diode Inspection in the Electrical System chapter)
  - Harness (see Wiring Inspection in the Electrical System chapter)
- ★ If the all parts are good condition, replace the ECU (see ECU Removal/Installation in the Fuel System (DFI) chapter).

#### **Engine Stop Switch Operation Inspection**

##### **First Step**

- Turn the ignition switch on.
- Set the gear position in the neutral position.
- Turn the engine stop switch to stop position [A].
- Push the starter button.
- The engine does not start.
- ★ If the engine starts, inspect or replace the engine stop switch (see Switch Inspection in the Electrical System chapter).

##### **Second Step**

- Turn the ignition switch on.
- Set the gear position in the neutral position.
- Turn the engine stop switch to run position [A].
- Push the starter button and start the engine.
- Turn the engine stop switch to stop position.
- Immediately the engine should be stop.
- ★ If the engine does not stop, inspect or replace the engine stop switch (see Switch Inspection in the Electrical System chapter).
- ★ If the engine stop switch is good condition, replace the ECU (see ECU Removal/Installation in the Fuel System (DFI) chapter).



**Periodic Maintenance Procedures**

**Spark Plug Replacement**

- Disconnect the spark plug cap.

**NOTICE**

**When removing the spark plug cap, do not pull the lead. The lead could break off or damage the wire inside.**

- Remove the spark plug using the 16 mm (0.63 in.) plug wrench [A] vertically.
- Replace the spark plug with a new one.

**Spark Plug**

Type: **NGK CR6HSA**

- Insert the new spark plug [A] in the spark plug hole [B], and finger-tighten it first.
- Using the 16 mm (0.63 in.) plug wrench vertically, tighten the spark plug.

Special Tool - Spark Plug Wrench, Hex 16: 57001-1262

**NOTICE**

**If tightening the spark plug with the wrench inclined, the insulator of the spark plug may break.**

Torque - Spark Plug: 13 N·m (1.3 kgf·m, 115 in·lb)

- Install the spark plug cap.
- After installation, be sure the spark plug cap is installed securely by pulling up it lightly.

**Others**

**Chassis Parts Lubrication**

- Before lubricating each part, clean off any rusty spots with rust remover and wipe off any grease, oil, dirt, or grime.
- Lubricate the points listed below with indicated lubricant.

**NOTE**

○Whenever the vehicle has been operated under wet or rainy conditions, or especially after using a high-pressure water spray, perform the general lubrication.

**Pivots: Lubricate with Grease.**

- Brake Lever
- Brake Pedal
- Clutch Lever (BR125H/J)
- Side Stand

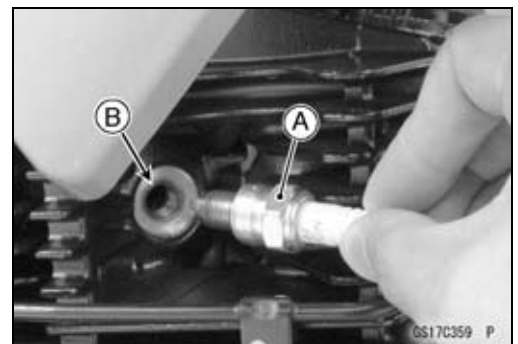
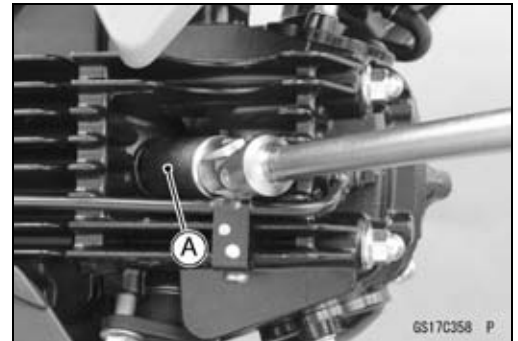

## 2-46 PERIODIC MAINTENANCE

### Periodic Maintenance Procedures

#### Points: Lubricate with Grease.

Clutch Inner Cable Upper and Lower Ends [A]  
(BR125H/J)

Throttle Inner Cable Upper and Lower Ends

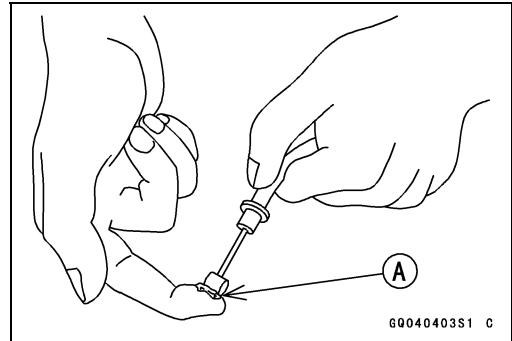

#### Cables: Lubricate with Rust Inhibitor.

Clutch Cable (BR125H/J)

Throttle Cable

- Lubricate the cables by seeping the oil between the cable and housing.
- The cable may be lubricated by using a commercially available pressure cable lubricator with an aerosol cable lubricant.

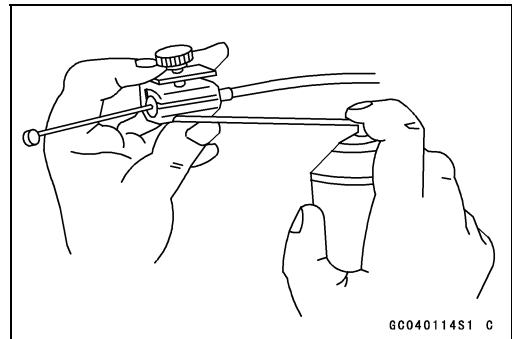

- With the cable disconnected at both ends, the cable should move freely [A] within the cable housing.
- ★ If cable movement is not free after lubricating, if the cable is frayed [B], or if the cable housing is kinked [C], replace the cable.

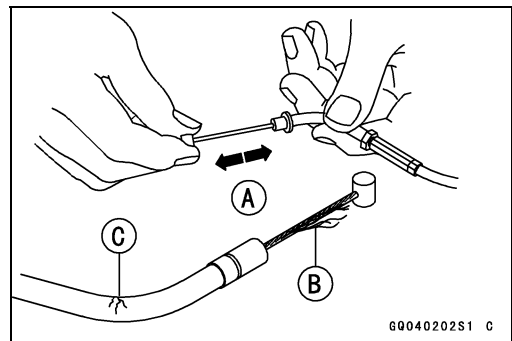

## Periodic Maintenance Procedures

---

### ***Condition of Bolts, Nuts and Fasteners Tightness Inspection***

- Check the tightness of the bolts and nuts listed here. Also, check to see that each cotter pin is in place and in good condition.

#### **NOTE**

○ *For the engine fasteners, check the tightness of them when the engine is cold (at room temperature).*

- ★ If there are loose fasteners, retighten them to the specified torque following the specified tightening sequence. Refer to the appropriate chapter for torque specifications. If torque specifications are not in the appropriate chapter, see the Standard Torque Table. For each fastener, first loosen it by 1/2 turn, then tighten it.
- ★ If cotter pins are damaged, replace them with new ones.

### **Bolt, Nut and Fastener to be checked**

Engine:

Clutch Lever Pivot Bolt Locknut (BR125H/J)  
 Engine Mounting Nuts  
 Exhaust Pipe Holder Nuts  
 Muffler Body Mounting Bolt

Wheels:

Front Axle Nut  
 Front Axle Nut Cotter Pin  
 Rear Axle Nut  
 Rear Axle Nut Cotter Pin

Brakes:

Brake Lever Pivot Bolt Locknut  
 Brake Pedal Cotter Pin  
 Caliper Mounting Bolts  
 Front Master Cylinder Clamp Bolts  
 Rear Master Cylinder Mounting Bolts  
 Rear Master Cylinder Push Rod Joint Cotter Pin

Suspension:

Front Fork Clamp Bolts  
 Rear Shock Absorber Bolts  
 Swingarm Pivot Shaft Nut

Steering:

Handlebar Clamp Bolts  
 Steering Stem Head Nut

Others:

Front Footpeg Bracket Bolts  
 Side Stand Bolt and Nut





# Fuel System (DFI)

## Table of Contents

Exploded View.....	3-3	Engine Temperature Sensor Output Voltage Inspection.....	3-51
DFI System.....	3-10	Engine Temperature Sensor Resistance Inspection.....	3-52
DFI Components Naming .....	3-12	Crankshaft Sensor (Service Code 21) (DTC P0335).....	3-53
DFI Parts Location.....	3-19	Crankshaft Sensor Removal/Installation.....	3-53
Specifications .....	3-21	Crankshaft Sensor Resistance Inspection.....	3-53
Special Tools and Sealant.....	3-23	Crankshaft Sensor Peak Voltage Inspection.....	3-53
DFI Servicing Precautions.....	3-24	Speed Sensor (Service Code 24) (DTC P0720).....	3-54
DFI Servicing Precautions .....	3-24	Speed Sensor Removal/Installa- tion .....	3-54
Troubleshooting the DFI System .....	3-26	Speed Sensor Inspection.....	3-54
Outline .....	3-26	Speed Sensor Input Voltage Inspection.....	3-54
Inquiries to Rider.....	3-29	Speed Sensor Output Voltage Inspection.....	3-55
DFI System Troubleshooting Guide ..	3-32	Vehicle-down Sensor (Service Code 31) (DTC C0064) .....	3-57
Self-Diagnosis .....	3-36	Vehicle-down Sensor Removal ...	3-57
Self-diagnosis Outline .....	3-36	Vehicle-down Sensor Installation .	3-57
Self-diagnosis Procedures .....	3-36	Vehicle-down Sensor Input Voltage Inspection.....	3-58
Service Code Reading .....	3-38	Vehicle-down Sensor Output Voltage Inspection.....	3-59
Service Code Erasing .....	3-38	Oxygen Sensor - not activated (Service Code 33) (DTC P0130, P0132) .....	3-62
Service Code Table.....	3-39	Oxygen Sensor Removal/Installa- tion .....	3-62
Backups .....	3-40	Oxygen Sensor Inspection.....	3-62
Throttle Sensor (Service Code 11) (DTC P0120, P0123).....	3-42	Fuel Injector (Service Code 41) (DTC P0201) .....	3-64
Throttle Sensor Removal/Adjust- ment.....	3-42	Fuel Injector Removal.....	3-64
Throttle Sensor Input Voltage Inspection.....	3-42	Fuel Injector Installation.....	3-65
Throttle Sensor Output Voltage Inspection.....	3-43	Fuel Injector Audible Inspection...	3-66
Intake Air Pressure Sensor (Service Code 12) (DTC P0105, P0106, P0107).....	3-46	Fuel Injector Resistance Inspection.....	3-66
Intake Air Pressure Sensor Removal.....	3-46	Fuel Injector Power Source Voltage Inspection.....	3-67
Intake Air Pressure Sensor Input Voltage Inspection.....	3-46	Fuel Injector Output Voltage Inspection.....	3-67
Intake Air Pressure Sensor Output Voltage Inspection.....	3-47	Fuel Injector Fuel Line Inspection	3-68
Intake Air Temperature Sensor (Service Code 13) (DTC P0110, P0112) .....	3-49	Ignition Coil (Service Code 51) (DTC P0351) .....	3-71
Intake Air Temperature Sensor Removal.....	3-49	Ignition Coil Removal/Installation.	3-71
Intake Air Temperature Sensor Output Voltage Inspection.....	3-49		
Intake Air Temperature Sensor Resistance Inspection.....	3-50		
Engine Temperature Sensor (Service Code 14) (DTC P0115, P0117).....	3-51		
Engine Temperature Sensor Removal/Installation.....	3-51		

## 3-2 FUEL SYSTEM (DFI)

Ignition Coil Primary Winding Resistance Inspection .....	3-71	Fuel Pressure Inspection .....	3-87
Ignition Coil Input Voltage Inspection .....	3-71	Fuel Flow Rate Inspection .....	3-88
Oxygen Sensor Heater (Service Code 67) (DTC P0030) .....	3-73	Fuel Pump .....	3-91
Oxygen Sensor Heater Removal/Installation .....	3-73	Fuel Pump Removal .....	3-91
Oxygen Sensor Heater Resistance Inspection .....	3-73	Fuel Pump Installation .....	3-92
Oxygen Sensor Heater Power Source Voltage Inspection .....	3-73	Fuel Pump Operation Inspection ..	3-92
Fuel Supply System (Service Code 94) (DTC P0170) .....	3-76	Fuel Pump Operating Voltage Inspection .....	3-93
Fuel Supply System Inspection .....	3-76	Pressure Regulator Removal .....	3-94
Idle Speed Control Valve Actuator (Service Code 1C) (DTC P0508, P0511, P0519) .....	3-77	Fuel Filter Cleaning .....	3-94
Idle Speed Control Valve Actuator Removal .....	3-77	Throttle Grip and Cable .....	3-95
Idle Speed Control Valve Actuator Installation .....	3-77	Free Play Inspection .....	3-95
Idle Speed Control Valve Actuator Resistance Inspection .....	3-77	Free Play Adjustment .....	3-95
Idle Speed Control Valve Actuator Input Voltage Inspection .....	3-78	Cable Installation .....	3-95
Purge Valve (Service Code 3A) (DTC P0443) (CAL Model) .....	3-80	Cable Lubrication .....	3-95
Purge Valve Removal/Installation .....	3-80	Throttle Body Assy .....	3-96
Purge Valve Inspection .....	3-80	Idle Speed Inspection/Adjustment ..	3-96
Yellow Engine Warning Indicator Light (LED) .....	3-82	Throttle Body Assy Removal .....	3-96
Yellow Engine Warning Indicator Light (LED) Inspection .....	3-82	Throttle Body Assy Installation .....	3-98
ECU .....	3-83	Intake Pipe .....	3-100
ECU Identification .....	3-83	Intake Pipe Removal .....	3-100
ECU Removal .....	3-83	Intake Pipe Installation .....	3-100
ECU Installation .....	3-83	Air Cleaner .....	3-101
Throttle Sensor Position Data Reset and Registration .....	3-84	Air Cleaner Element Removal/Installation .....	3-101
ECU Power Supply Inspection .....	3-85	Air Cleaner Element Inspection ...	3-101
Fuel Line .....	3-87	Air Cleaner Housing Removal .....	3-101
		Air Cleaner Housing Installation ...	3-102
		Fuel Tank .....	3-103
		Fuel Tank Removal .....	3-103
		Fuel Tank Installation .....	3-106
		Fuel Tank and Cap Inspection .....	3-107
		Fuel Tank Cleaning .....	3-108
		Evaporative Emission Control System (CAL Model) .....	3-109
		Parts Removal/Installation .....	3-109
		Hose Inspection .....	3-109
		Purge Valve Inspection .....	3-109
		Canister Removal .....	3-109
		Canister Installation .....	3-110
		Canister Inspection .....	3-110

---

**Exploded View**

---

This page intentionally left blank.

# 3-4 FUEL SYSTEM (DFI)

## Exploded View

Other than CAL Model

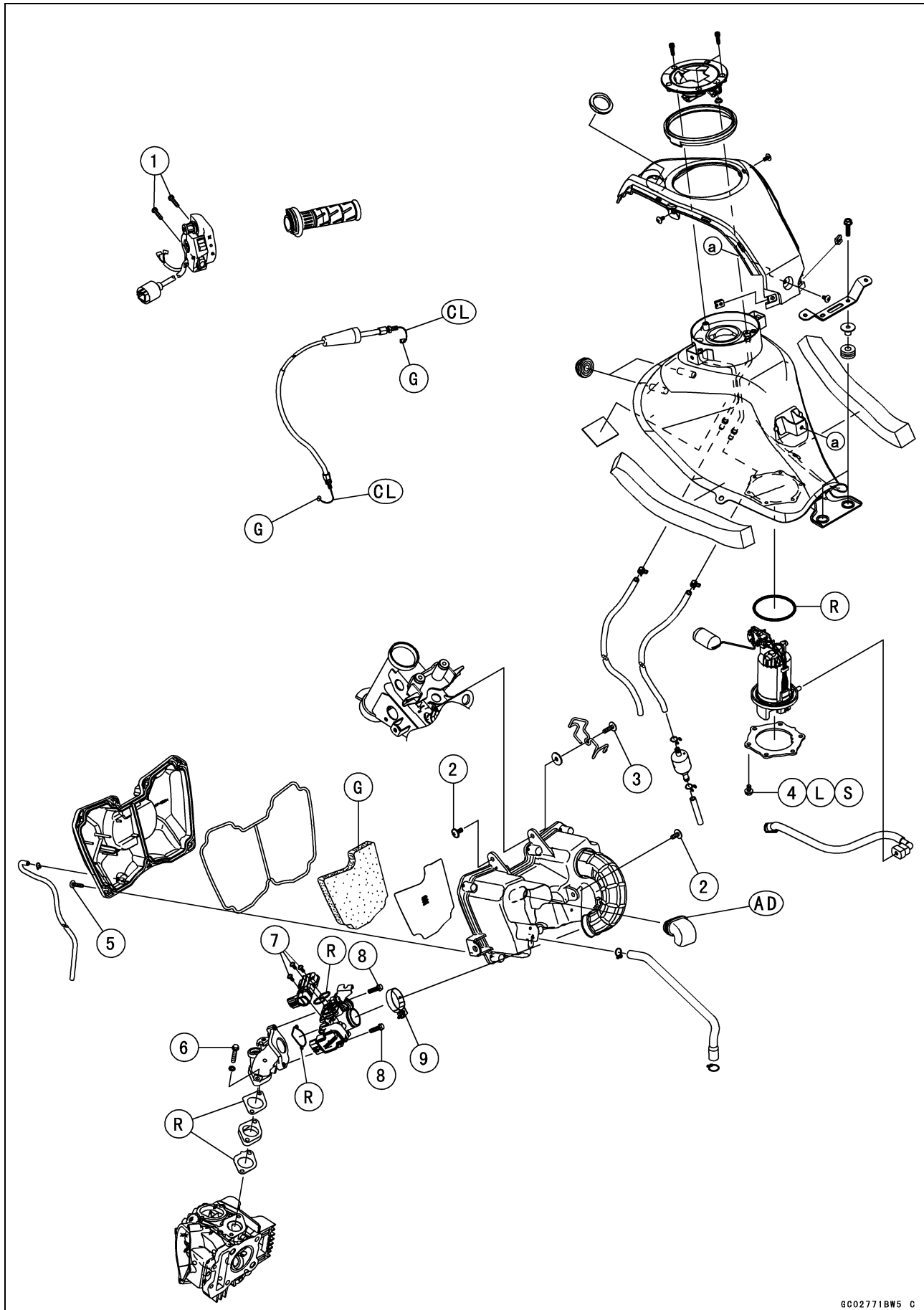

**Exploded View**

No.	Fastener	Torque			Remarks
		N·m	kgf·m	ft·lb	
1	Right Switch Housing Screws	3.5	0.36	31 in·lb	
2	Air Cleaner Housing Mounting Screws (L = 14 mm)	5.2	0.53	46 in·lb	
3	Air Cleaner Housing Mounting Screw (L = 20 mm)	3.5	0.36	31 in·lb	
4	Fuel Pump Bolts	9.8	1.0	87 in·lb	L, S
5	Air Cleaner Cover Screws	1.2	0.12	11 in·lb	
6	Intake Pipe Bolts	12	1.2	106 in·lb	
7	Idle Speed Control Valve Actuator Screws	2.1	0.21	19 in·lb	
8	Throttle Body Assy Mounting Bolts	8.8	0.90	78 in·lb	
9	Air Cleaner Housing Clamp Screw	2.0	0.20	18 in·lb	

AD: Apply adhesive.

CL: Apply cable lubricant.

G: Apply grease.

L: Apply a non-permanent locking agent.

R: Replacement Parts

S: Follow the specified tightening sequence.

# 3-6 FUEL SYSTEM (DFI)

## Exploded View

### CAL Model

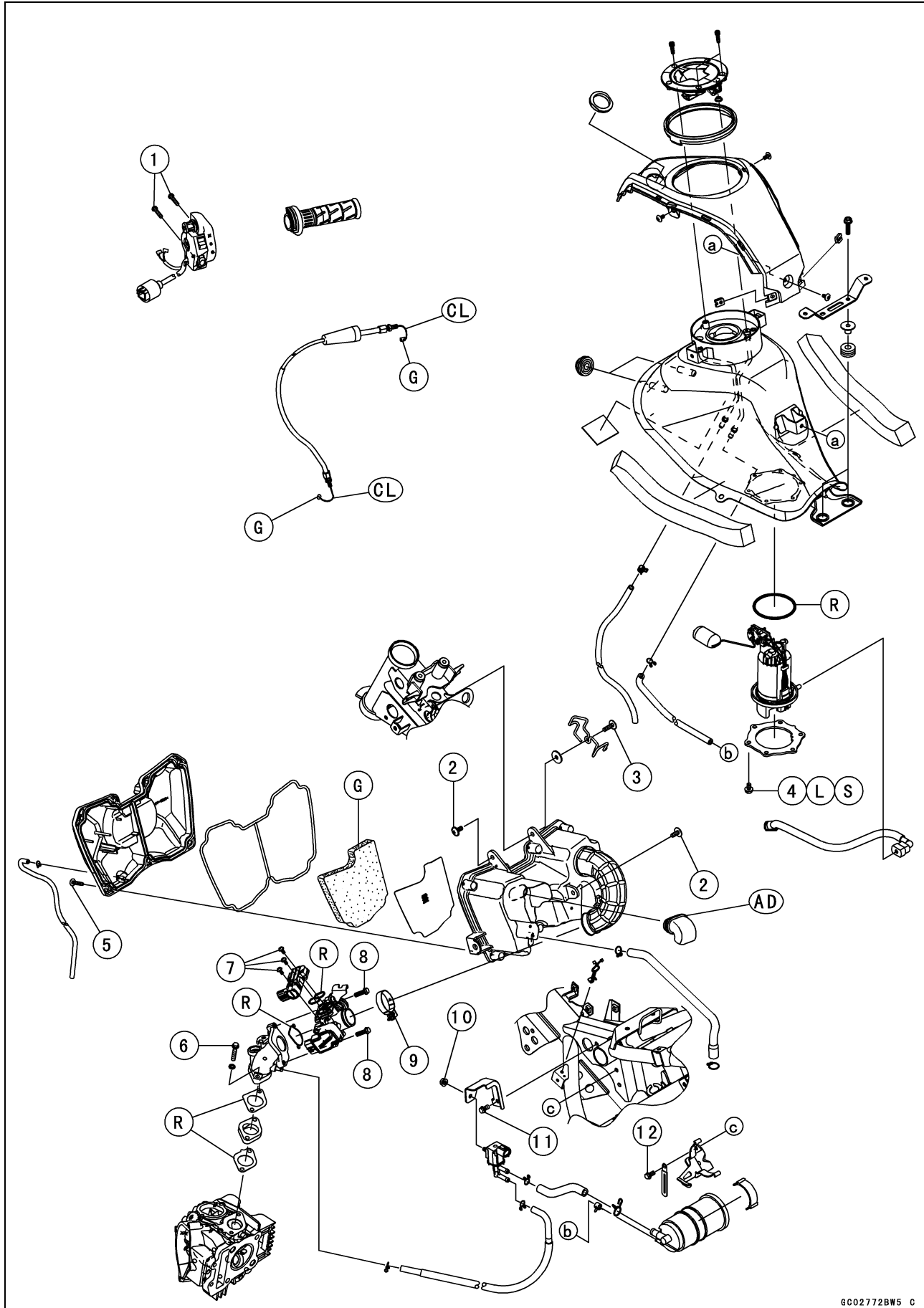

**Exploded View**

No.	Fastener	Torque			Remarks
		N·m	kgf·m	ft·lb	
1	Right Switch Housing Screws	3.5	0.36	31 in·lb	
2	Air Cleaner Housing Mounting Screws (L = 14 mm)	5.2	0.53	46 in·lb	
3	Air Cleaner Housing Mounting Screw (L = 20 mm)	3.5	0.36	31 in·lb	
4	Fuel Pump Bolts	9.8	1.0	87 in·lb	L, S
5	Air Cleaner Cover Screws	1.2	0.12	11 in·lb	
6	Intake Pipe Bolts	12	1.2	106 in·lb	
7	Idle Speed Control Valve Actuator Screws	2.1	0.21	19 in·lb	
8	Throttle Body Assy Mounting Bolts	8.8	0.90	78 in·lb	
9	Air Cleaner Housing Clamp Screw	2.0	0.20	18 in·lb	
10	Purge Valve Nut	8.8	0.90	78 in·lb	
11	Purge Valve Bracket Bolt	8.8	0.90	78 in·lb	
12	Canister Bracket Bolt	8.8	0.90	78 in·lb	

AD: Apply adhesive.

CL: Apply cable lubricant.

G: Apply grease.

L: Apply a non-permanent locking agent.

R: Replacement Parts

S: Follow the specified tightening sequence.

# 3-8 FUEL SYSTEM (DFI)

## Exploded View

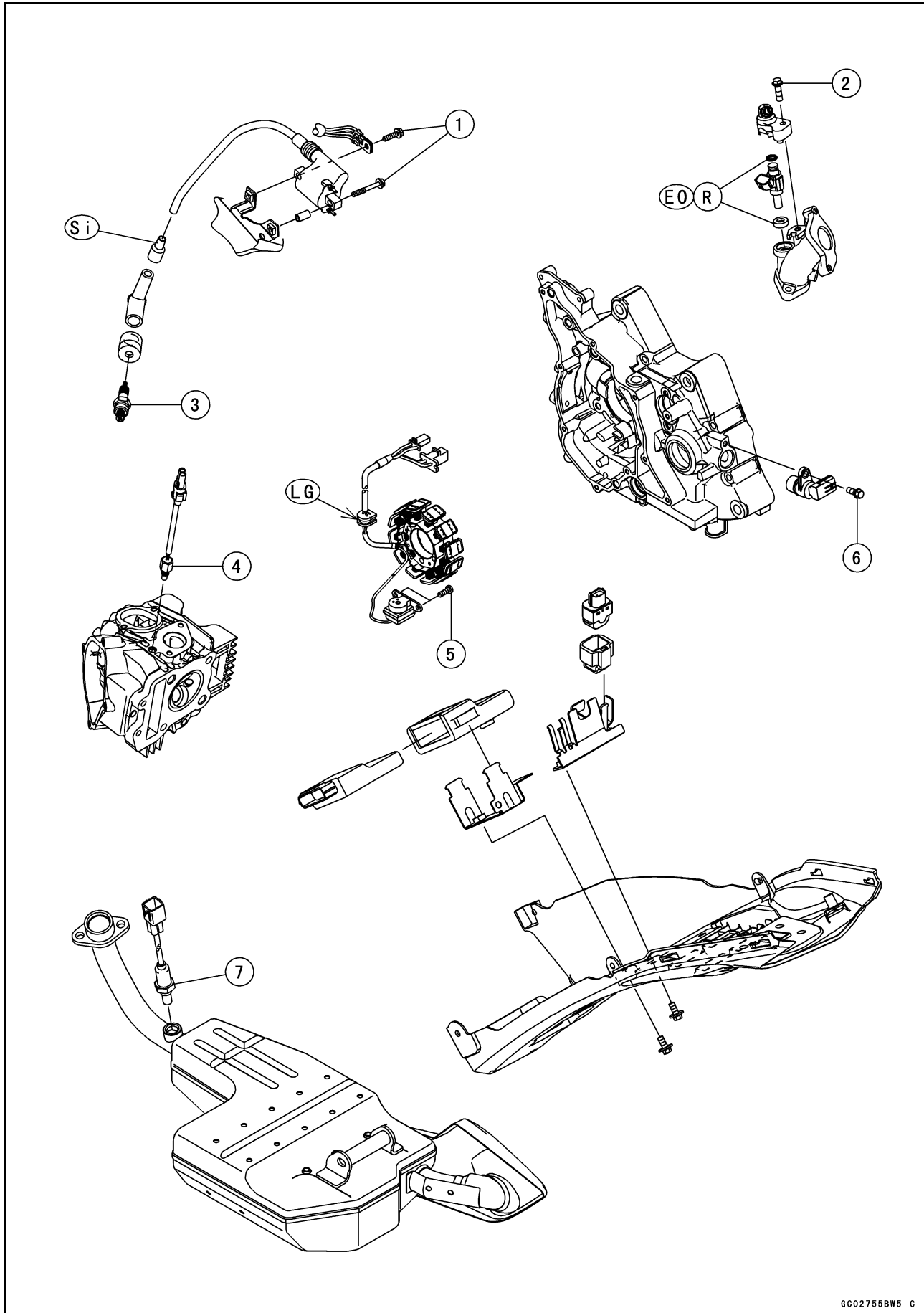



**Exploded View**

No.	Fastener	Torque			Remarks
		N·m	kgf·m	ft·lb	
1	Ignition Coil Mounting Bolts	4.0	0.41	35 in·lb	
2	Delivery Pipe Mounting Bolts	5.2	0.53	46 in·lb	
3	Spark Plug	13	1.3	115 in·lb	
4	Engine Temperature Sensor	9.8	1.0	87 in·lb	
5	Crankshaft Sensor Mounting Screws	2.9	0.30	26 in·lb	
6	Speed Sensor Bolt	5.2	0.53	46 in·lb	
7	Oxygen Sensor	25	2.5	18	

EO: Apply engine oil.

LG: Apply liquid gasket.

R: Replacement Parts

Si: Apply silicone grease.

# 3-10 FUEL SYSTEM (DFI)

## DFI System

### DFI System

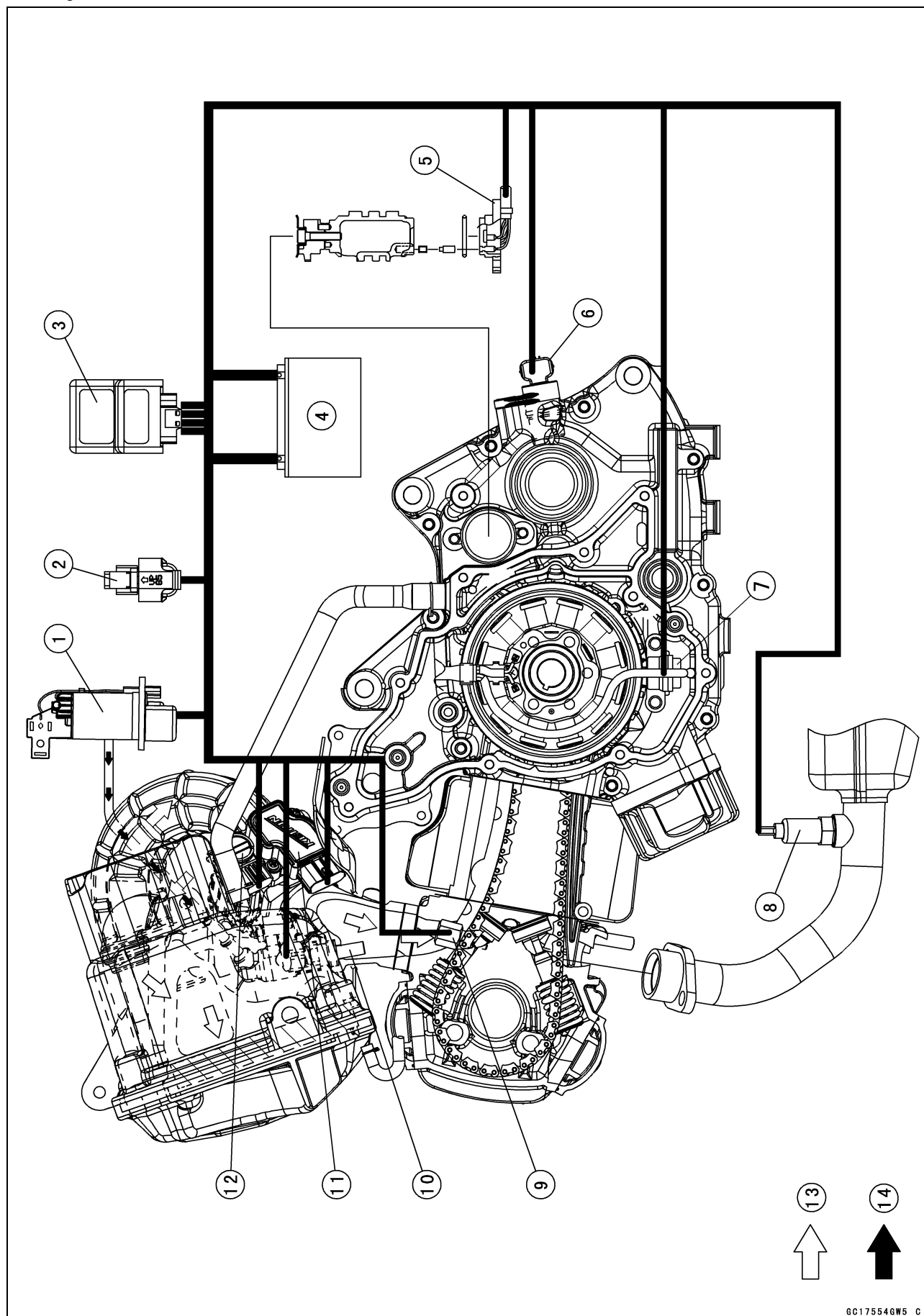

### DFI System

---

1. Fuel Pump
2. Vehicle-down Sensor
3. ECU
4. Battery 12 V 3 Ah
5. Gear Position Switch
6. Speed Sensor
7. Crankshaft Sensor
8. Oxygen Sensor
9. Engine Temperature Sensor
10. Fuel Injector
11. Throttle Body Assy Sensors
12. Idle Speed Control Valve Actuator
13. Air Flow
14. Fuel Flow

## 3-12 FUEL SYSTEM (DFI)

### DFI System

#### **DFI Components Naming**

The terms used in the European regulation for DFI components are sometimes different from those used by Kawasaki. Use this table to cross reference terms which may appear in a generic scan tool when diagnosing the DFI system.

<b>Sensors described in R44/2014 (Description per ISO 15031-6 in the parentheses)</b>	<b>Kawasaki Name</b>
Throttle position sensor (Throttle/Pedal position sensor/switch "A")	Throttle sensor
Manifold absolute pressure sensor (Manifold absolute pressure/barometric pressure circuit)	Intake air pressure sensor
Intake air temperature sensor (Intake air temperature sensor 1)	Intake air temperature sensor
Engine coolant temperature sensor (Engine coolant temperature sensor 1)	Engine temperature sensor
Crankshaft position sensor (Crankshaft position sensor "A")	Crankshaft sensor
Vehicle speed sensor (Vehicle speed sensor "B")	Speed sensor
O <sub>2</sub> sensor (binary/linear) signals (O <sub>2</sub> sensor)	Oxygen sensor

<b>Actuators described in R44/2014 (Description per ISO 15031-6 in the parentheses)</b>	<b>Kawasaki Name</b>
Evaporative emission system purge control valve (Evaporative emission system purge control valve)	Purge valve
Fuel injector (Injector - cylinder 1)	Fuel injector
O <sub>2</sub> sensor heater (HO <sub>2</sub> S heater control circuit)	Oxygen sensor heater
Idle air control system (Idle air control system)	Idle speed control valve actuator
Ignition coil primary control circuits (Ignition coil "A" primary/secondary circuit)	Ignition coil

---

**DFI System**

---

This page intentionally left blank.

# 3-14 FUEL SYSTEM (DFI)

## DFI System

### DFI System Wiring Diagram (Other than CAL Model)

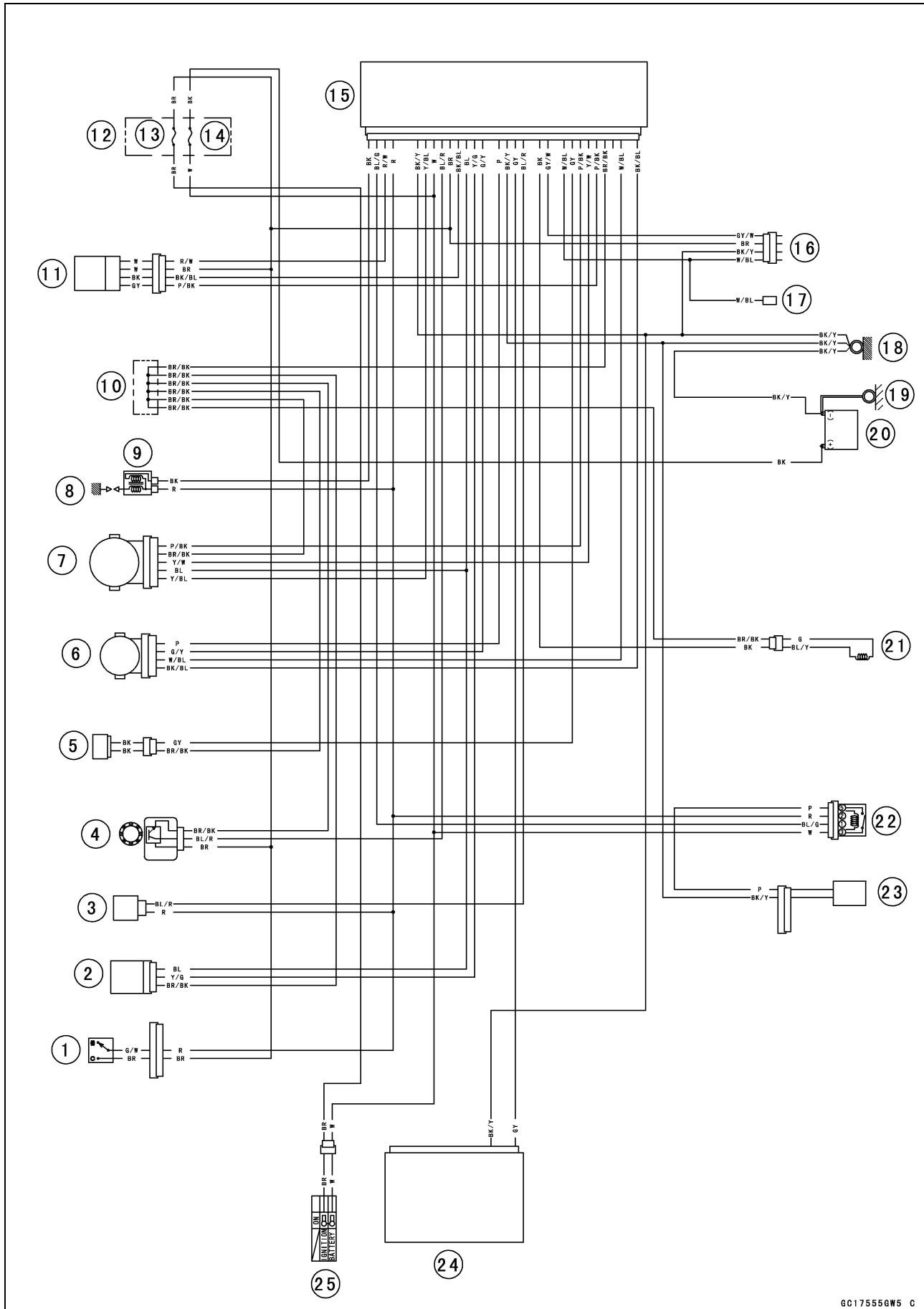

## DFI System

---

### Part Names

1. Engine Stop Switch
2. Vehicle-down Sensor
3. Fuel Injector
4. Speed Sensor
5. Engine Temperature Sensor
6. Idle Speed Control Valve Actuator
7. Throttle Body Assy Sensors
8. Spark Plug
9. Ignition Coil
10. Water-proof Joint
11. Oxygen Sensor
12. Fuse Box
13. Ignition Fuse 10 A
14. Battery Fuse 20 A
15. ECU
16. Kawasaki Diagnostic System Connector
17. Self-diagnosis Terminal
18. Frame Ground
19. Engine Ground
20. Battery 12 V 3 Ah
21. Crankshaft Sensor
22. Fuel Pump Relay
23. Fuel Pump
24. Meter Unit
25. Ignition Switch

### ○Color Codes:

BK: Black	GY: Gray	PU: Purple
BL: Blue	LB: Light Blue	R: Red
BR: Brown	LG: Light Green	V: Violet
CH: Chocolate	O: Orange	W: White
DG: Dark Green	P: Pink	Y: Yellow
G: Green		

# 3-16 FUEL SYSTEM (DFI)

## DFI System

### DFI System Wiring Diagram (CAL Model)

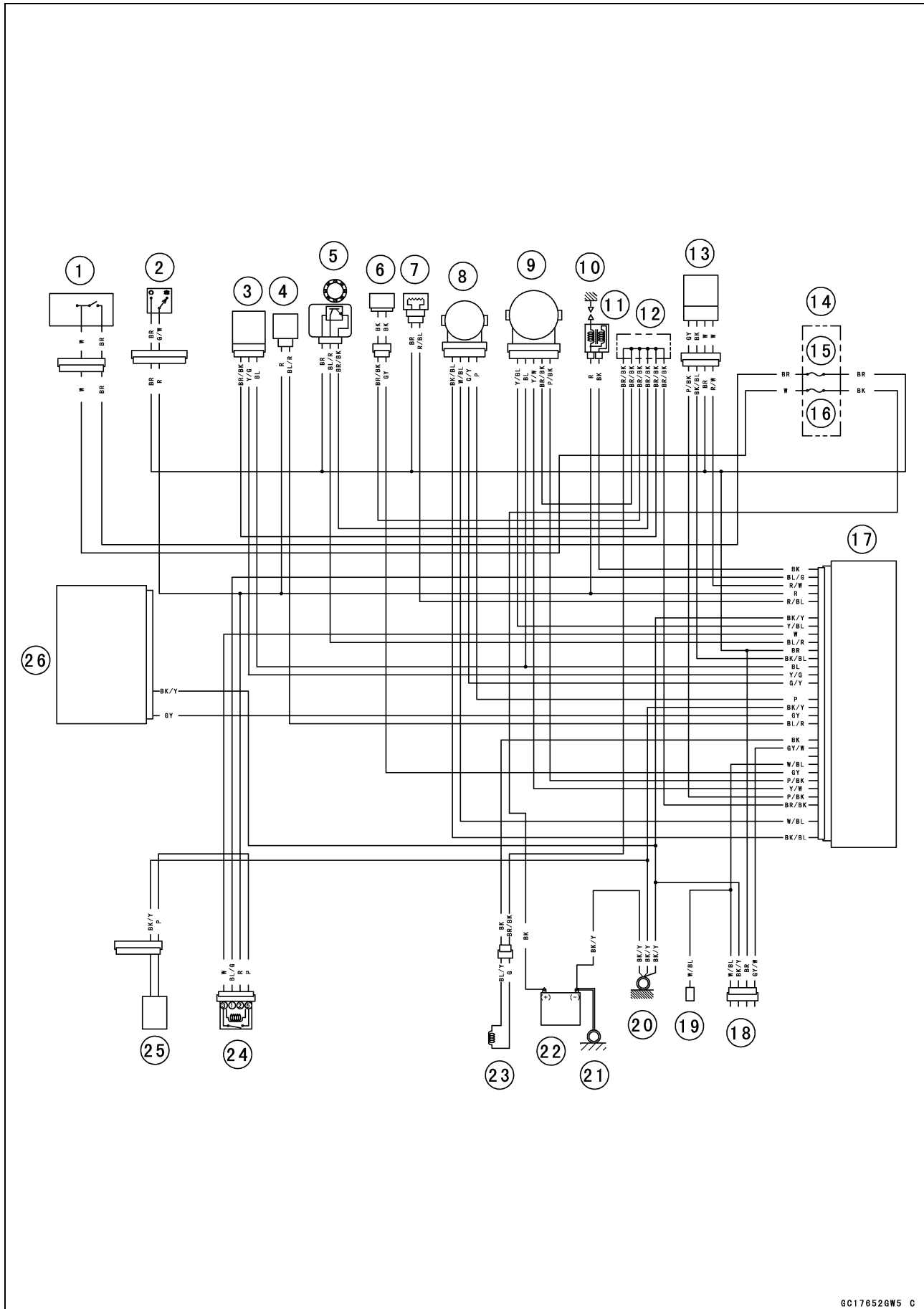



---

**DFI System**

---

**Part Names**

1. Ignition Switch
2. Engine Stop Switch
3. Vehicle-down Sensor
4. Fuel Injector
5. Speed Sensor
6. Engine Temperature Sensor
7. Purge Valve
8. Idle Speed Control Valve Actuator
9. Throttle Body Assy Sensors
10. Spark Plug
11. Ignition Coil
12. Water-proof Joint
13. Oxygen Sensor
14. Fuse Box
15. Ignition Fuse 10 A
16. Battery Fuse 20 A
17. ECU
18. Kawasaki Diagnostic System Connector
19. Self-diagnosis Terminal
20. Frame Ground
21. Engine Ground
22. Battery 12 V 3 Ah
23. Crankshaft Sensor
24. Fuel Pump Relay
25. Fuel Pump
26. Meter Unit

## ○Color Codes:

BK: Black	GY: Gray	PU: Purple
BL: Blue	LB: Light Blue	R: Red
BR: Brown	LG: Light Green	V: Violet
CH: Chocolate	O: Orange	W: White
DG: Dark Green	P: Pink	Y: Yellow
G: Green		

# 3-18 FUEL SYSTEM (DFI)

## DFI System

### Terminal Numbers of ECU Connector

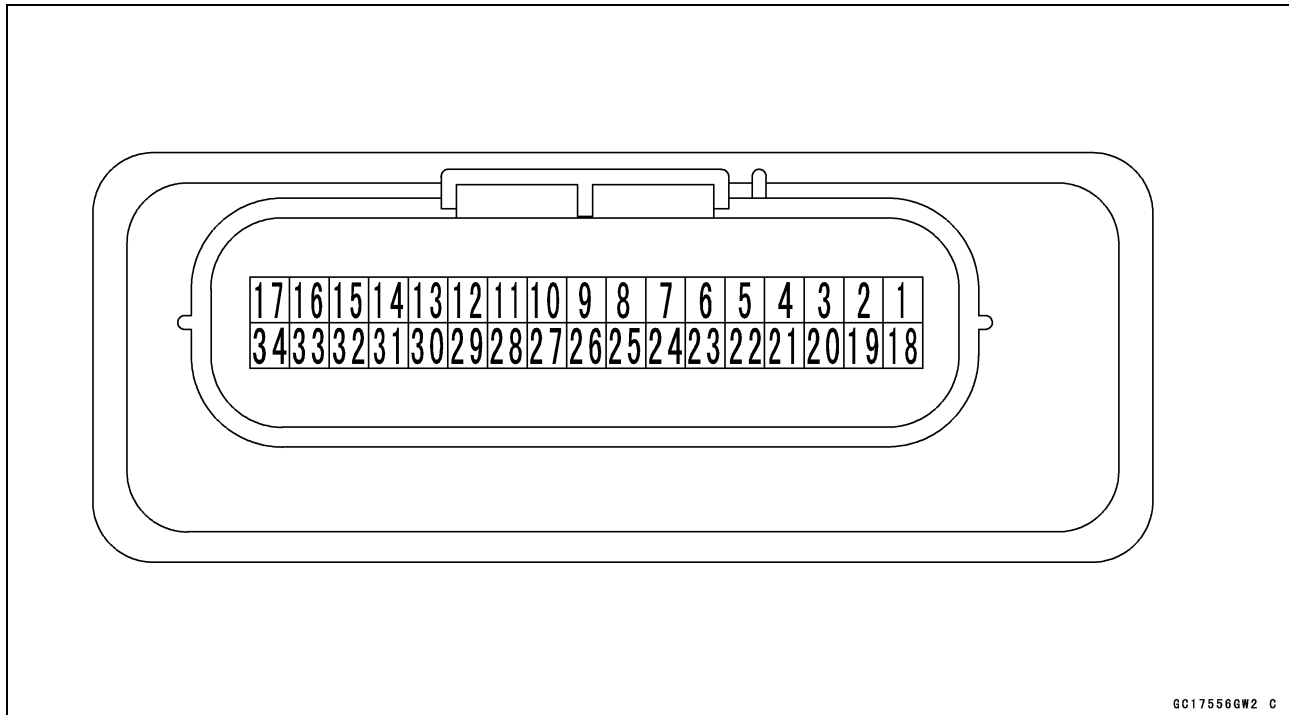

### Terminal Names

- |   |  |
|---|--|
| 1. Ignition Coil: BK  | 19. Yellow Engine Warning Indicator Light: GY                  |
| 2. Fuel Pump Relay: BL/G  | 20. Fuel Injector: BL/R  |
| 3. Oxygen Sensor Heater: R/W  | 21. Starter Switch: BK/R                                       |
| 4. Engine Stop Switch: R  | 22. Crankshaft Sensor: BK                                      |
| 5. Unused (Other than CAL Model)<br>Purge Valve (CAL Model): R/BL       | 23. External Communication Line (*KDS):<br>GY/W                |
| 6. Neutral Switch: LG   | 24. Unused   |
| 7. Ground for ECU: BK/Y   | 25. Self-diagnosis Terminal: W/BL                              |
| 8. Intake Air Pressure Sensor: Y/BL                                     | 26. Engine Temperature Sensor: GY                              |
| 9. Power Supply to ECU (from Battery): W                                | 27. Intake Air Temperature Sensor: P/BK                        |
| 10. Speed Sensor: BL/R  | 28. Throttle Sensor: Y/W                                       |
| 11. Power Supply to ECU (from Ignition<br>Switch): BR                   | 29. Oxygen Sensor (-): P/BK                                    |
| 12. Oxygen Sensor (+): BK/BL  | 30. Ground for Sensors: BR/BK                                  |
| 13. Power Supply to Sensors: BL   | 31. Unused   |
| 14. Vehicle-down Sensor: Y/G  | 32. Idle Speed Control Valve Actuator: W/BL                    |
| 15. Idle Speed Control Valve Actuator: G/Y                              | 33. Unused (BR125G)<br>Starter Lockout Switch (BR125H/J): BL/R |
| 16. Ground for ECU (BR125G/H): BK/Y<br>Side Stand Switch (BR125J): BK/Y | 34. Idle Speed Control Valve Actuator: BK/BL                   |
| 17. Idle Speed Control Valve Actuator: P                                | *: KDS (Kawasaki Diagnostic System)                            |
| 18. Ground for ECU: BK/Y  |  |

DFI Parts Location

Fuel Injector [A]

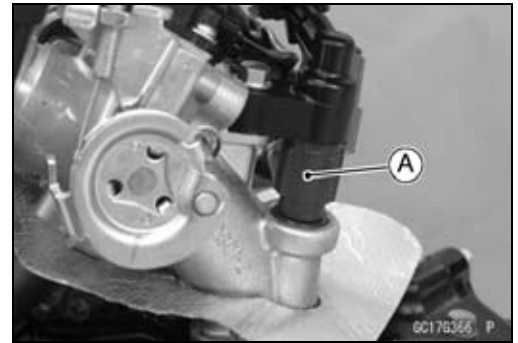

Throttle Body Assy Sensors [A]  
Idle Speed Control Valve Actuator [B]



Ignition Coil [A]

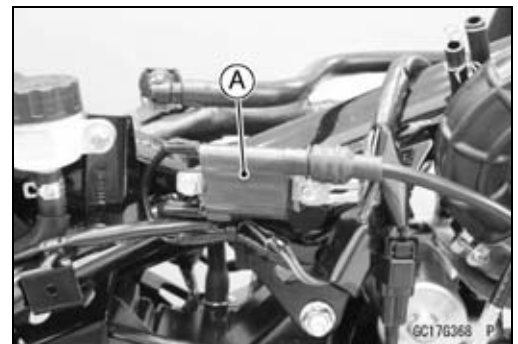

Engine Temperature Sensor [A]  
Crankshaft Sensor [B]

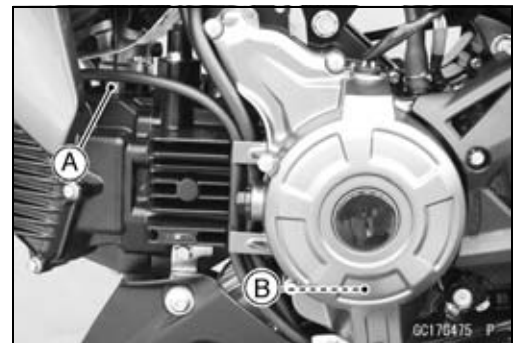

Oxygen Sensor [A]



## 3-20 FUEL SYSTEM (DFI)

### DFI Parts Location

- Fuel Pump Relay [A]
- ECU [B]
- Vehicle-down Sensor [C]
- Battery 12 V 3 Ah [D]
- Fuse Box [E]
- Kawasaki Diagnostic System Connector [F]
- Self-diagnosis Terminal [G]

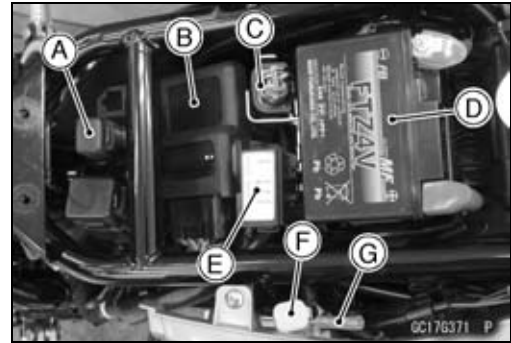

- Fuel Pump [A]

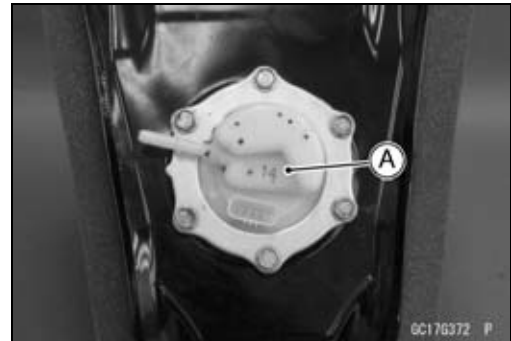

- Speed Sensor [A]



- Yellow Engine Warning Indicator Light (LED) [A]



**Specifications**

Item	Standard
<b>Digital Fuel Injection System</b>	
Idle Speed	1 500 ±50 r/min (rpm)
Throttle Body Assy:	
Throttle Valve	Single Throttle Valve
Bore	φ24 mm (0.94 in.)
ECU (Electronic Control Unit):	
Make	MITSUBISHI ELECTRIC
Type	Digital memory type, with built in IC igniter, sealed with resin
Fuel Pressure (High Pressure Line)	294 kPa (3.0 kgf/cm <sup>2</sup> , 43 psi) with engine idling
Fuel Pump:	
Type	In-tank pump (in fuel pump)
Discharge	11 mL (0.37 US oz.) or more for 3 seconds
Fuel Injector:	
Type	EAT820
Nozzle Type	Fine atomizing type with 4 holes
Resistance	About 11.5 ~ 12.5 Ω @20°C (68°F)
Throttle Sensor:	
Input Voltage	DC 4.75 ~ 5.25 V
Output Voltage	DC 0.29 ~ 0.71 V at idle throttle opening DC 4.13 ~ 4.76 V at full throttle opening (for reference)
Intake Air Pressure Sensor:	
Input Voltage	DC 4.75 ~ 5.25 V
Output Voltage	DC 2.90 V at standard atmospheric pressure (101.32 kPa, 76 cmHg) (for reference)
Intake Air Temperature Sensor:	
Output Voltage	About DC 2.80 ~ 3.10 V @20°C (68°F)
Resistance	1.04 ~ 1.23 kΩ @40°C (104°F) 0.148 ~ 0.162 kΩ @100°C (212°F)
Engine Temperature Sensor:	
Output Voltage	About DC 3.4 ~ 3.8 V @20°C (68°F)
Speed Sensor:	
Input Voltage	Battery Voltage
Output Voltage	About DC 0.03 ~ 5 V at rear wheel turning
Vehicle-down Sensor:	
Input Voltage	DC 4.75 ~ 5.25 V
Output Voltage	With sensor tilted 60 ~ 70° or more right or left: DC 0.65 ~ 1.35 V With sensor arrow mark pointed up: DC 3.55 ~ 4.45 V
Oxygen Sensor:	
Output Voltage (Rich)	DC 0.8 V or more
Output Voltage (Lean)	DC 0.24 V or less
Heater Resistance	13.0 ~ 18.5 Ω @20°C (68°F)

## 3-22 FUEL SYSTEM (DFI)

### Specifications

Item	Standard
Idle Speed Control Valve Actuator: Resistance Input Voltage  Purge Valve (CAL Model): Resistance	About 120 $\Omega$ @20°C (68°F) About DC 7.2 ~ 14.2 V and then 0 V or About DC 7.2 ~ 14.2 V  30 ~ 34 $\Omega$ @20°C (68°F)
<b>Throttle Grip and Cables</b> Throttle Grip Free Play	2 ~ 3 mm (0.08 ~ 0.12 in.)
<b>Air Cleaner</b> Air Cleaner Element Air Cleaner Element Oil	Polyurethane foam element High-quality foam air filter oil

Special Tools and Sealant

Oil Pressure Gauge, 5 kgf/cm<sup>2</sup>:  
57001-125

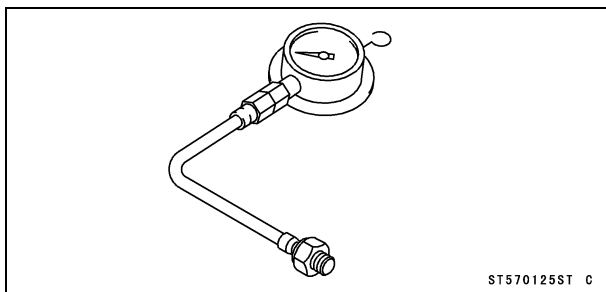

Fuel Hose:  
57001-1607

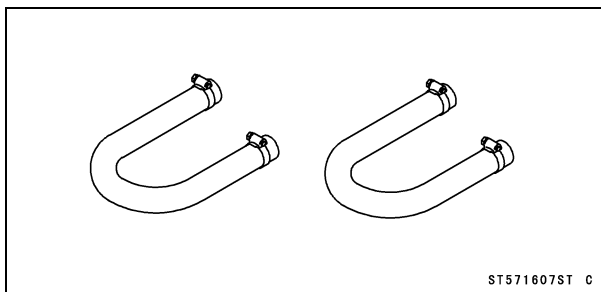

Peak Voltage Adapter:  
57001-1415

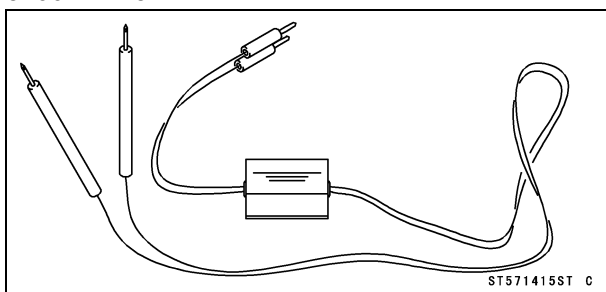

Measuring Adapter:  
57001-1700

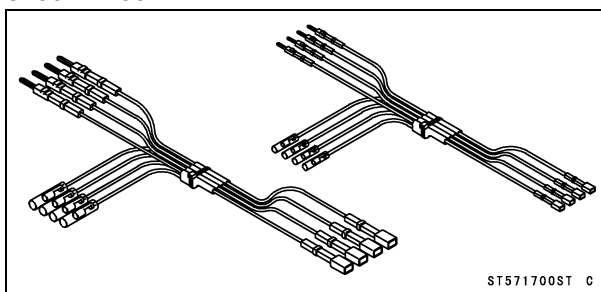

Needle Adapter Set:  
57001-1457

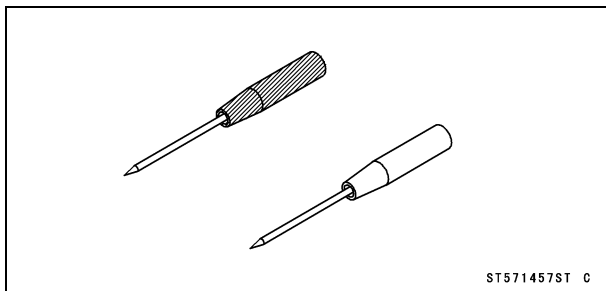

Liquid Gasket, TB1211:  
56019-120

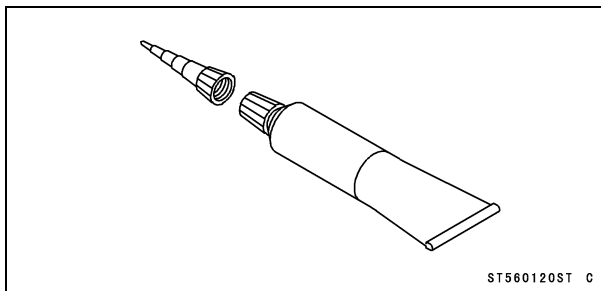

Fuel Pressure Gauge Adapter:  
57001-1593

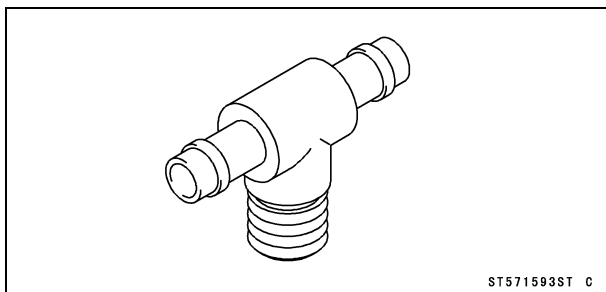

## 3-24 FUEL SYSTEM (DFI)

### DFI Servicing Precautions

#### DFI Servicing Precautions

There are a number of important precautions that should be followed servicing the DFI system.

- This DFI system is designed to be used with a 12 V sealed battery as its power source. Do not use any other battery except for a 12 V sealed battery as a power source.
- Do not reverse the battery cable connections. This will damage the ECU.
- To prevent damage to the DFI parts, do not disconnect the battery cables or any other electrical connections when the ignition switch is on, or while the engine is running.
- Take care not to short the leads that are directly connected to the battery positive (+) terminal to the chassis ground.
- When charging, remove the battery from the motorcycle. This is to prevent ECU damage by excessive voltage.
- Whenever the DFI electrical connections are to be disconnected, first turn off the ignition switch, and disconnect the battery (–) terminal. Do not pull the lead, only the connector. Conversely, make sure that all the DFI electrical connections are firmly reconnected before starting the engine.
- Connect these connectors until they click [A].

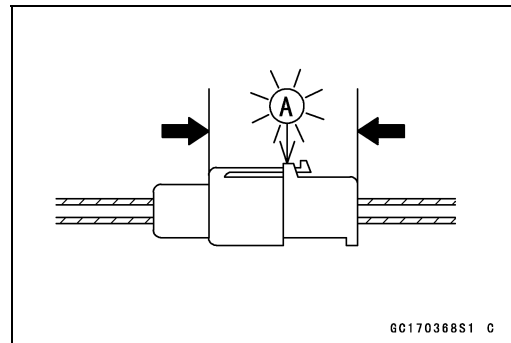

- Do not turn the ignition switch on while any of the DFI electrical connectors are disconnected. The ECU memorizes service codes.
- Do not spray water on the electrical parts, DFI parts, connectors, leads and wiring.
- If a transceiver is installed on the motorcycle, make sure that the operation of the DFI system is not influenced by electric wave radiated from the antenna. Check operation of the system with the engine at idle. Locate the antenna as far as possible away from the ECU.
- When any fuel hose is disconnected, do not turn on the ignition switch. Otherwise, the fuel pump will operate and fuel will spout from the fuel hose.
- Do not operate the fuel pump if the pump is completely dry. This is to prevent pump seizure.
- Before removing the fuel system parts, blow the outer surfaces of these parts clean with compressed air.
- When any fuel hose is disconnected, fuel may spout out by residual pressure in the fuel line. Cover the hose joint with a piece of clean cloth to prevent fuel spillage.
- When installing the fuel hose, avoid sharp bending, kinking, flattening or twisting, and run the fuel hose with a minimum of bending so that the fuel flow will not be obstructed.
- Run the hose according to Cable, Wire, and Hose Routing section in the Appendix chapter.
- To prevent corrosion and deposits in the fuel system, do not add to fuel any fuel antifreeze chemicals.



### DFI Servicing Precautions

○If the motorcycle is not properly handled, the high pressure inside the fuel line can cause fuel to leak or the hose to burst. Remove the fuel tank (see Fuel Tank Removal) and check the fuel hose [A].

★Replace the fuel hose if any fraying, cracks or bulges are noticed.

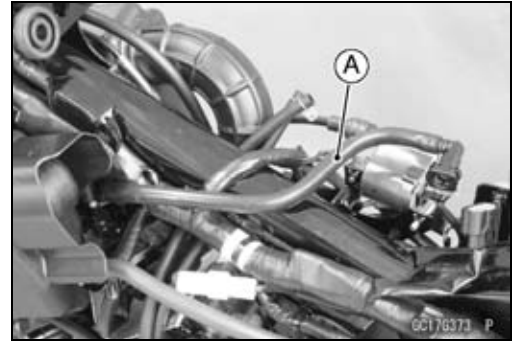

○To maintain the correct fuel/air mixture (F/A), there must be no intake air leaks in the DFI system. Be sure to install the oil filler plug/dipstick [A] after filling the engine oil.

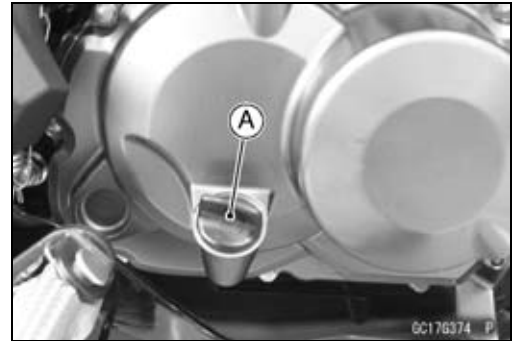

## 3-26 FUEL SYSTEM (DFI)

### Troubleshooting the DFI System

#### Outline

When an abnormality in the system occurs, the yellow engine warning indicator light (LED) stays on after starting the engine to alert the rider on the meter panel. In addition, the condition of the problem is stored in the memory of the ECU. With the engine stopped and turned in the self-diagnosis mode, the service code [A] is indicated by the number of times the yellow engine warning indicator light (LED) blinks.

When due to a malfunction, the yellow engine warning indicator light (LED) remains lit, ask the rider about the conditions [B] under which the problem occurred and try to determine the cause [C].

- First, conduct a self-diagnosis inspection and then a non-self-diagnosis inspection. The non-self-diagnosis items are not indicated by the yellow engine warning indicator light (LED). Don't rely solely on the DFI self-diagnosis function, use common sense.

Even when the DFI system is operating normally, the yellow engine warning indicator light (LED) goes on may be displayed under strong electrical interference. Additional measures are not required. Turn the ignition switch off to stop the indicator light.

If the yellow engine warning indicator light (LED) of the motorcycle brought in for repair still goes on, check the service code.

When the repair has been done, the yellow engine warning indicator light (LED) goes off after the service code erasing procedure (see Service Code Erasing) is done. But the service codes stored in memory of the ECU are not erased to preserve the problem history. The problem history can be referred using the KDS (Kawasaki Diagnostic System) when solving unstable problems.

When the motorcycle is down, the vehicle-down sensor operates and the ECU shuts off the fuel pump relay, fuel injector and ignition system. The ignition switch is left on. If the starter button is pushed, the electric starter turns but the engine does not start. To start the engine again, raise the motorcycle, turn the ignition switch off, and then on.

Much of the DFI system troubleshooting work consists of confirming continuity of the wiring. The DFI parts are assembled and adjusted with precision, and it is impossible to disassemble or repair them.

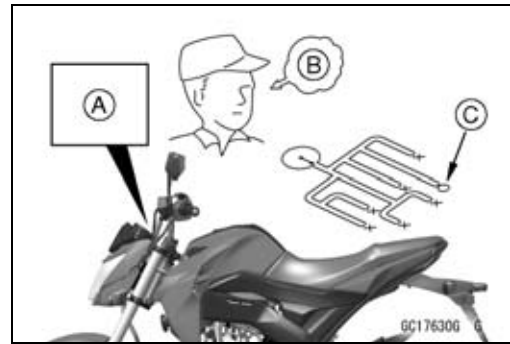

**Troubleshooting the DFI System**

- When checking the DFI parts, use a digital meter which can be read two decimal place voltage or resistance.
- The DFI part connectors [A] have seals [B], including the ECU. When measuring the input or output voltage with the connector joined, use the needle adapter set [C]. Insert the needle adapter inside the seal until the needle adapter reaches the terminal.

**Special Tool - Needle Adapter Set: 57001-1457**

**NOTICE**

**Insert the needle adapter straight along the terminal in the connector to prevent short-circuit between terminals.**

- Make sure that measuring points are correct in the connector, noting the position of the lock [D] and the lead color before measurement. Do not reverse connections of a digital meter.
- Be careful not to short-circuit the leads of the DFI or electrical system parts by contact between adapters.
- Turn the ignition switch on and measure the voltage with the connector joined.

**NOTICE**

**Incorrect, reverse connection or short circuit by needle adapters could damage the DFI or electrical system parts.**

- After measurement, remove the needle adapters and apply silicone sealant to the seals [A] of the connector [B] for waterproofing.

**Sealant - Liquid Gasket, TB1211: 56019-120**

- Always check battery condition before replacing the DFI parts. A fully charged battery is a must for conducting accurate tests of the DFI system.
- Trouble may involve one or in some cases all items. Never replace a defective part without determining what CAUSED the problem. If the problem was caused by some other item or items, they too must be repaired or replaced, or the new replacement part will soon fail again.
- Measure coil winding resistance when the DFI part is cold (at room temperature).
- Make sure all connectors in the circuit are clean and tight, and examine leads for signs of burning, fraying, short, etc. Deteriorated leads and bad connections can cause reappearance of problems and unstable operation of the DFI system.
- ★ If any wiring is deteriorated, replace the wiring.

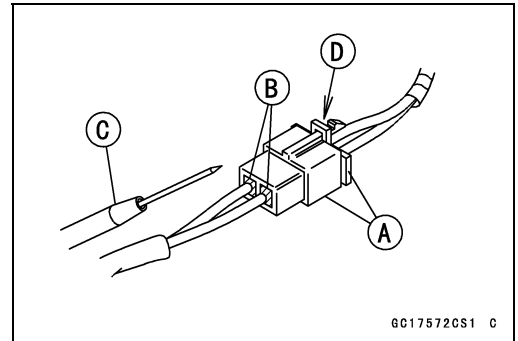

GC17572CS1 C

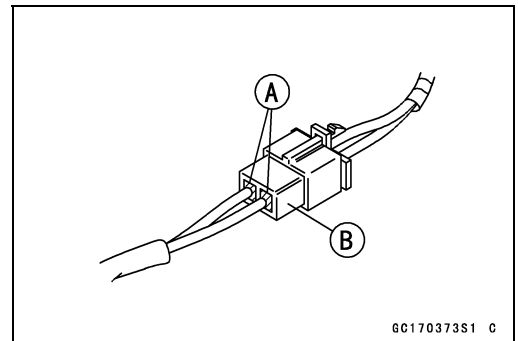

GC170373S1 C

## 3-28 FUEL SYSTEM (DFI)

### Troubleshooting the DFI System

- Pull each connector [A] apart and inspect it for corrosion, dirt, and damage.
- ★ If the connector is corroded or dirty, clean it carefully. If it is damaged, replace it. Connect the connectors securely.
- Check the wiring for continuity.
- Use the wiring diagram to find the ends of the lead which is suspected of being a problem.
- Connect a tester between the ends of the leads.
- ★ If the tester does not read about 0  $\Omega$ , the lead is defective. Replace the lead or the main harness.

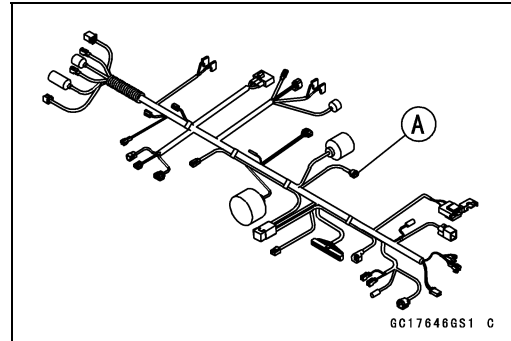

- If both ends of a harness [A] are far apart, ground [B] the one end [C], using a jumper lead [D] and check the continuity between the end [E] and the ground [F]. This enables to check a long harness for continuity. If the harness is open, repair or replace the harness.

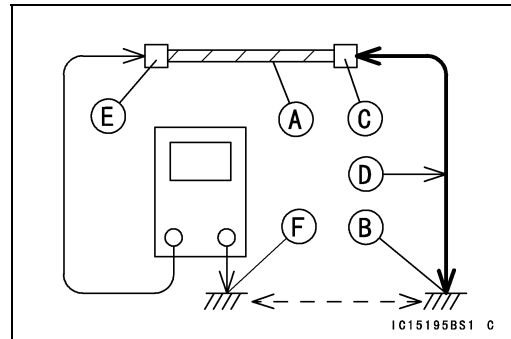

- When checking a harness [A] for short circuit, open one end [B] and check the continuity between the other end [C] and ground [D]. If there is continuity, the harness has a short circuit to ground, and it must be repaired or replaced.

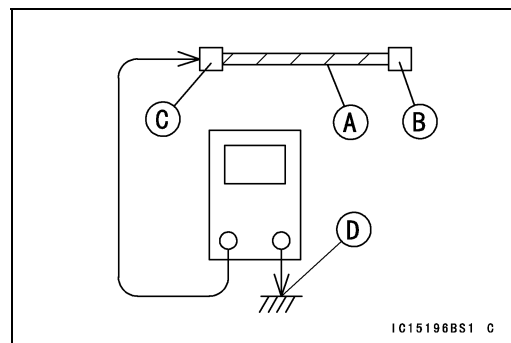

- Narrow down suspicious locations by repeating the continuity tests from the ECU connector.
- ★ If no abnormality is found in the wiring or connectors, the DFI parts are the next likely suspects. Check the part, starting with input and output voltages. However, there is no way to check the ECU itself.
- ★ If an abnormality is found, replace the affected DFI part.
- ★ If no abnormality is found in the wiring, connectors, and DFI parts, replace the ECU.

Troubleshooting the DFI System

DFI Diagnosis Flow Chart

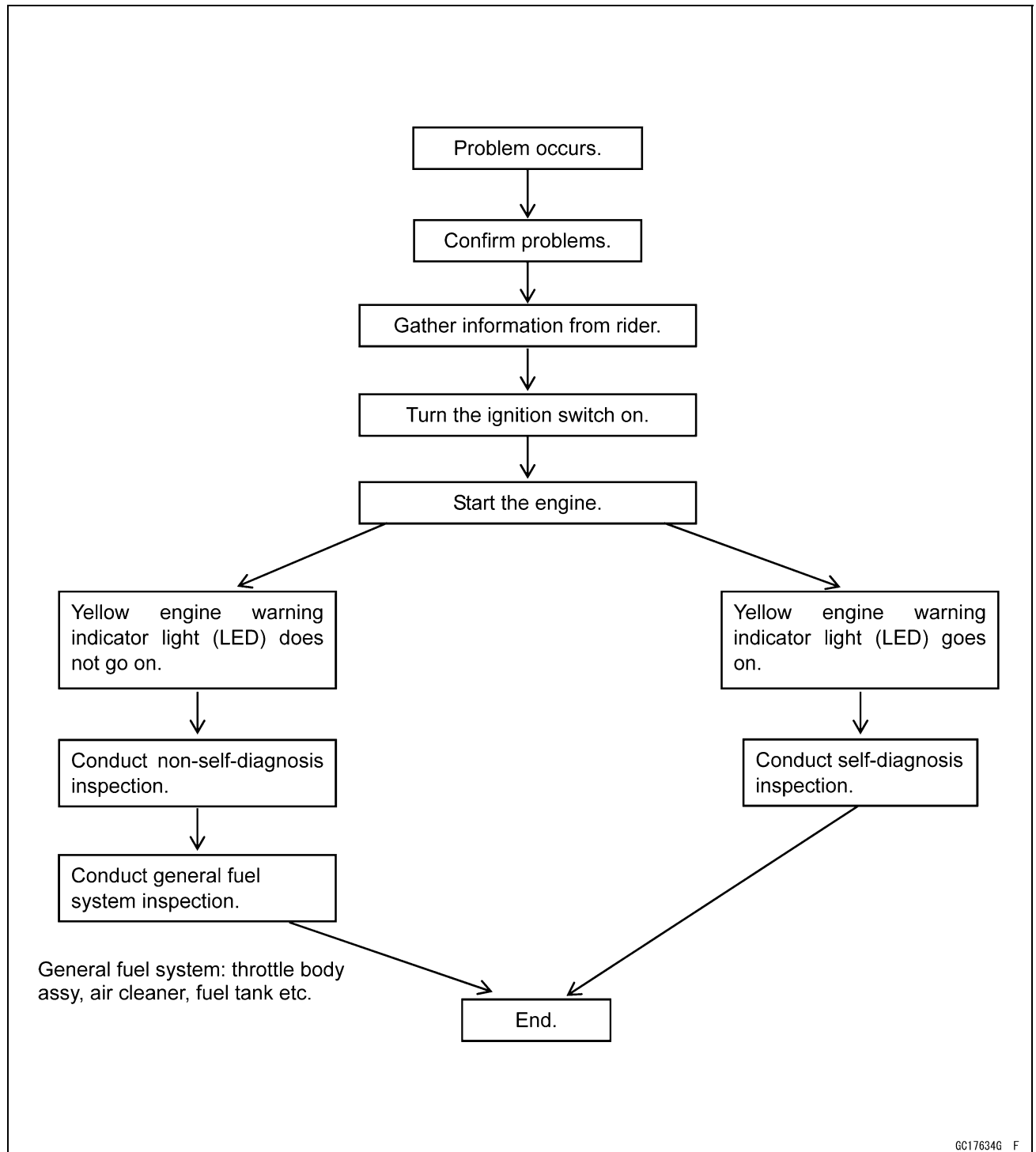

**Inquiries to Rider**

- Each rider reacts to problems in different ways, so it is important to confirm what kind of symptoms the rider has encountered.
- Try to find out exactly what problem occurred under exactly what conditions by asking the rider; knowing this information may help you reproduce the problem.
- The following sample diagnosis sheet will help prevent you from overlooking any areas, and will help you decide if it is a DFI system problem, or a general engine problem.

### 3-30 FUEL SYSTEM (DFI)

#### Troubleshooting the DFI System

#### Sample Diagnosis Sheet

<b>Rider name:</b>	<b>Registration No. (license plate No.):</b>	<b>Year of initial registration:</b>
<b>Model:</b>	<b>Engine No.:</b>	<b>Frame No.:</b>
<b>Date problem occurred:</b>		<b>Mileage:</b>
<b>Environment when problem occurred.</b>		
Weather	<input type="checkbox"/> fine, <input type="checkbox"/> cloudy, <input type="checkbox"/> rain, <input type="checkbox"/> snow, <input type="checkbox"/> always, <input type="checkbox"/> other:	
Temperature	<input type="checkbox"/> hot, <input type="checkbox"/> warm, <input type="checkbox"/> cold, <input type="checkbox"/> very cold, <input type="checkbox"/> always, <input type="checkbox"/> other:	
Problem frequency	<input type="checkbox"/> chronic, <input type="checkbox"/> often, <input type="checkbox"/> once	
Road	<input type="checkbox"/> street, <input type="checkbox"/> highway, <input type="checkbox"/> mountain road ( <input type="checkbox"/> uphill, <input type="checkbox"/> downhill), <input type="checkbox"/> bumpy, <input type="checkbox"/> pebble	
Altitude	<input type="checkbox"/> normal, <input type="checkbox"/> high (about 1 000 m or more)	
<b>Motorcycle conditions when problem occurred.</b>		
Yellow engine warning indicator light (LED)	<input type="checkbox"/> goes on immediately after turning the ignition switch on, and goes off after starting the engine (normal)	
	<input type="checkbox"/> goes on immediately after turning the ignition switch on, after starting the engine and stays on after starting the engine (DFI problem)	
	<input type="checkbox"/> does not go on after turning the ignition switch on [indicator light (LED), meter unit fault]	
Starting difficulty	<input type="checkbox"/> starter motor not rotating.	
	<input type="checkbox"/> starter motor rotating but engine do not turn over.	
	<input type="checkbox"/> starter motor and engine do not turn over.	
	<input type="checkbox"/> no fuel flow ( <input type="checkbox"/> no fuel in tank, <input type="checkbox"/> no fuel pump sound).	
	<input type="checkbox"/> no spark.	
<input type="checkbox"/> other:		
Engine stalls	<input type="checkbox"/> right after starting.	
	<input type="checkbox"/> when opening throttle grip.	
	<input type="checkbox"/> when closing throttle grip.	
	<input type="checkbox"/> when moving off.	
	<input type="checkbox"/> when stopping the motorcycle.	
	<input type="checkbox"/> when cruising.	
<input type="checkbox"/> other:		
Poor running at low speed	<input type="checkbox"/> very low idle speed, <input type="checkbox"/> very high idle speed, <input type="checkbox"/> rough idle speed.	
	<input type="checkbox"/> battery voltage is low (charge the battery).	
	<input type="checkbox"/> spark plug loose (tighten it).	
	<input type="checkbox"/> spark plug dirty, broken, or gap maladjusted (remedy it).	
	<input type="checkbox"/> backfiring.	
	<input type="checkbox"/> afterfiring.	
	<input type="checkbox"/> hesitation when acceleration.	
	<input type="checkbox"/> engine oil viscosity too high.	
	<input type="checkbox"/> brake dragging.	
	<input type="checkbox"/> engine overheating.	
	<input type="checkbox"/> clutch slipping.	
<input type="checkbox"/> other:		

**Troubleshooting the DFI System**

Poor running or no power at high speed	<input type="checkbox"/> spark plug loose (tighten it).
	<input type="checkbox"/> spark plug dirty, broken, or gap maladjusted (remedy it).
	<input type="checkbox"/> spark plug incorrect (replace it).
	<input type="checkbox"/> knocking (fuel poor quality or incorrect).
	<input type="checkbox"/> brake dragging.
	<input type="checkbox"/> clutch slipping.
	<input type="checkbox"/> engine overheating.
	<input type="checkbox"/> engine oil level too high.
	<input type="checkbox"/> engine oil viscosity too high.
	<input type="checkbox"/> other:

## 3-32 FUEL SYSTEM (DFI)

### DFI System Troubleshooting Guide

#### NOTE

- *This is not an exhaustive list, giving every possible cause for each problem listed. It is meant simply as a rough guide to assist the troubleshooting for some of the more common difficulties in DFI system.*
- *The ECU may be involved in the DFI electrical and ignition system troubles. If these parts and circuits are checked out good, be sure to check the ECU for ground and power supply. If the ground and power supply are checked good, replace the ECU.*

#### Engine Won't Turn Over

Symptoms or Possible Causes	Actions (chapter)
Gear position switch, starter lockout switch (BR125H/J) or Side Stand Switch (BR125J) trouble	Inspect each switch (see chapter 15).
Vehicle-down sensor operated	Turn ignition switch off (see chapter 3).
Vehicle-down sensor trouble	Inspect (see chapter 3).
Crankshaft sensor trouble	Inspect (see chapter 15).
Ignition coil shorted or not in good contact	Inspect or reinstall (see chapter 15).
Ignition coil trouble	Inspect (see chapter 15).
Spark plug dirty, broken or gap maladjusted	Inspect and replace (see chapter 2).
Spark plug incorrect	Replace it with the correct plug (see chapter 2).
ECU ground and power supply trouble	Inspect (see chapter 3).
ECU trouble	Inspect (see chapter 3).
No or little fuel in tank	Supply fuel (see Owner's Manual).
Fuel injector trouble	Inspect (see chapter 3).
Fuel pump not operating	Inspect (see chapter 3).
Fuel pump relay trouble	Inspect and replace (see chapter 15).
Fuel filter clogged	Inspect and replace fuel pump (see chapter 3).
Fuel pressure regulator trouble	Inspect fuel pressure and replace fuel pump (see chapter 3).
Fuel line clogged	Inspect and repair (see chapter 3).
Idle speed control valve actuator trouble	Inspect (see chapter 3).

#### Poor Running at Low Speed

Symptoms or Possible Causes	Actions (chapter)
<b>Spark weak:</b>	
Ignition coil shorted or not in good contact	Inspect or reinstall (see chapter 15).
Ignition coil trouble	Inspect (see chapter 15).
Spark plug dirty, broken or gap maladjusted	Inspect and replace (see chapter 2).
Spark plug incorrect	Replace it with the correct plug (see chapter 2).
ECU trouble	Inspect (see chapter 3).
<b>Fuel/air mixture incorrect:</b>	
Little fuel in tank	Supply fuel (see Owner's Manual).
Air cleaner clogged, poorly sealed, or missing	Clean element or inspect sealing (see chapter 2).
Air duct loose	Reinstall (see chapter 3).
Throttle body assy dust seal damage	Replace (see chapter 3).
Fuel injector O-ring damage	Replace (see chapter 3).
Fuel filter clogged	Inspect and replace fuel pump (see chapter 3).



**DFI System Troubleshooting Guide**

Symptoms or Possible Causes	Actions (chapter)
Fuel pressure regulator trouble	Inspect fuel pressure and replace fuel pump (see chapter 3).
Fuel line clogged	Inspect and repair (see chapter 3).
Intake air pressure sensor trouble	Inspect (see chapter 3).
Engine temperature sensor trouble	Inspect (see chapter 3)
Intake air temperature sensor trouble	Inspect (see chapter 3).
Throttle sensor trouble	Inspect (see chapter 3).
<b>Unstable (rough) idling:</b>	
Fuel pressure too low or too high	Inspect (see chapter 3).
Fuel injector trouble	Inspect (see chapter 3).
Throttle sensor trouble	Inspect (see chapter 3).
Intake air pressure sensor trouble	Inspect (see chapter 3).
Engine temperature sensor trouble	Inspect (see chapter 3)
Intake air temperature sensor trouble	Inspect (see chapter 3).
Idle speed control valve actuator trouble	Inspect (see chapter 3).
<b>Engine stalls easily:</b>	
Spark plug dirty, broken or gap maladjusted	Inspect and replace (see chapter 2).
Ignition coil trouble	Inspect (see chapter 15).
Throttle sensor trouble	Inspect (see chapter 3).
Intake air pressure sensor trouble	Inspect (see chapter 3).
Engine temperature sensor trouble	Inspect (see chapter 3)
Intake air temperature sensor trouble	Inspect (see chapter 3).
Fuel pump trouble	Inspect (see chapter 3).
Fuel injector trouble	Inspect (see chapter 3).
Fuel pressure too low or too high	Inspect (see chapter 3).
Fuel pressure regulator trouble	Inspect fuel pressure and replace fuel pump (see chapter 3).
Fuel line clogged	Inspect and repair (see chapter 3).
Idle speed control valve actuator trouble	Inspect (see chapter 3).
<b>Poor acceleration:</b>	
Fuel pressure too low	Inspect (see chapter 3).
Water or foreign matter in fuel	Change fuel. Inspect and clean fuel system (see chapter 3).
Fuel filter clogged	Inspect and replace fuel pump (see chapter 3).
Fuel pump trouble	Inspect (see chapter 3).
Fuel injector trouble	Inspect (see chapter 3).
Throttle sensor trouble	Inspect (see chapter 3).
Intake air pressure sensor trouble	Inspect (see chapter 3).
Engine temperature sensor trouble	Inspect (see chapter 3)
Intake air temperature sensor trouble	Inspect (see chapter 3).
Spark plug dirty, broken or gap maladjusted	Inspect and replace (see chapter 2).
Ignition coil trouble	Inspect (see chapter 15).
<b>Stumble:</b>	
Fuel pressure too low	Inspect (see chapter 3).
Fuel injector trouble	Inspect (see chapter 3).

### 3-34 FUEL SYSTEM (DFI)

#### DFI System Troubleshooting Guide

Symptoms or Possible Causes	Actions (chapter)
Throttle sensor trouble	Inspect (see chapter 3).
Intake air pressure sensor trouble	Inspect (see chapter 3).
Engine temperature sensor trouble	Inspect (see chapter 3)
Intake air temperature sensor trouble	Inspect (see chapter 3).
<b>Surge:</b>	
Unstable fuel pressure	Fuel pressure regulator trouble (Inspect and replace fuel pump) or kinked fuel line (Inspect and replace fuel pump) (see chapter 3).
Fuel injector trouble	Inspect (see chapter 3).
<b>Backfiring when deceleration:</b>	
Spark plug dirty, broken or gap maladjusted	Inspect and replace (see chapter 2).
Fuel pressure too low	Inspect (see chapter 3).
Fuel pump trouble	Inspect (see chapter 3).
Throttle sensor trouble	Inspect (see chapter 3).
Intake air pressure sensor trouble	Inspect (see chapter 3).
Engine temperature sensor trouble	Inspect (see chapter 3)
Intake air temperature sensor trouble	Inspect (see chapter 3).
<b>After fire:</b>	
Spark plug burned or gap maladjusted	Replace (see chapter 2).
Fuel injector trouble	Inspect (see chapter 3).
Intake air pressure sensor trouble	Inspect (see chapter 3).
Engine temperature sensor trouble	Inspect (see chapter 3)
Intake air temperature sensor trouble	Inspect (see chapter 3).
<b>Other:</b>	
Intermittent any DFI fault and its recovery	Check that DFI connectors are clean and tight, and examine leads for signs of burning or fraying (see chapter 3).

#### Poor Running or No Power at High Speed

Symptoms or Possible Causes	Actions (chapter)
<b>Firing incorrect:</b>	
Ignition coil shorted or not in good contact	Inspect or reinstall (see chapter 15).
Ignition coil trouble	Inspect (see chapter 15).
Spark plug dirty, broken or gap maladjusted	Inspect and replace (see chapter 2).
Spark plug incorrect	Replace it with the correct plug (see chapter 2).
ECU trouble	Inspect (see chapter 3).
<b>Fuel/air mixture incorrect:</b>	
Air cleaner clogged, poorly sealed, or missing	Clean element or inspect sealing (see chapter 2).
Air duct loose	Reinstall (see chapter 3).
Throttle body assy dust seal damage	Replace (see chapter 3).
Water or foreign matter in fuel	Change fuel. Inspect and clean fuel system (see chapter 3).
Fuel injector O-ring damage	Replace (see chapter 3).
Fuel injector clogged	Inspect and repair (see chapter 3).
Fuel line clogged	Inspect and repair (see chapter 3).

**DFI System Troubleshooting Guide**

Symptoms or Possible Causes	Actions (chapter)
Fuel pump operates intermittently and often DFI fuse blows.	Fuel pump bearings may wear. Replace the fuel pump (see chapter 3).
Fuel pump trouble	Inspect (see chapter 3).
Intake air pressure sensor trouble	Inspect (see chapter 3).
Engine temperature sensor trouble	Inspect (see chapter 3)
Intake air temperature sensor trouble	Inspect (see chapter 3).
Throttle sensor trouble	Inspect (see chapter 3).
<b>Knocking:</b>	
Fuel poor quality or incorrect	Fuel change (Use the gasoline recommended in the Owner's Manual).
Spark plug incorrect	Replace it with the correct plug (see chapter 2).
Ignition coil trouble	Inspect (see chapter 15).
ECU trouble	Inspect (see chapter 3).
Intake air pressure sensor trouble	Inspect (see chapter 3).
Engine temperature sensor trouble	Inspect (see chapter 3)
Intake air temperature sensor trouble	Inspect (see chapter 3).
<b>Miscellaneous:</b>	
Throttle valve will not fully open	Inspect throttle cable and lever linkage (see chapter 3).
Engine overheating - Crankshaft sensor trouble	(see Overheating of Troubleshooting Guide in chapter 16)
<b>Exhaust Smokes Excessively:</b>	
<b>(Black smoke)</b>	
Air cleaner element clogged	Clean element (see chapter 2).
Fuel pressure too high	Inspect (see chapter 3).
Fuel injector trouble	Inspect (see chapter 3).
Engine temperature sensor trouble	Inspect (see chapter 3)
Intake air temperature sensor trouble	Inspect (see chapter 3).
<b>(Brown smoke)</b>	
Air duct loose	Reinstall (see chapter 3).
Fuel pressure too low	Inspect (see chapter 3).
Engine temperature sensor trouble	Inspect (see chapter 3)
Intake air temperature sensor trouble	Inspect (see chapter 3).

## 3-36 FUEL SYSTEM (DFI)

### Self-Diagnosis

#### Self-diagnosis Outline

The self-diagnosis system has two modes and can be switched to another mode by grounding the self-diagnosis terminal.

#### User Mode

The ECU notifies the rider of troubles in DFI system and ignition system by lighting the yellow engine warning indicator light (LED) when DFI system and ignition system parts are faulty, and initiates fail-safe function. In case of serious troubles, the ECU stops the injection and ignition operation.

#### Dealer Mode

The yellow engine warning indicator light (LED) emits service code(s) to show the problem(s) which the DFI system and ignition system have at the moment of diagnosis.

#### Self-diagnosis Procedures

- Turn the ignition switch on and start the engine.
- When a problem occurs with the DFI system and ignition system, the yellow engine warning indicator light (LED) [A] goes on.

#### NOTE

- Use a fully charged battery when conducting self-diagnosis. Otherwise, the yellow engine warning indicator light (LED) blinks very slowly or does not blink.

- Remove the seat (see Seat Removal in the Frame chapter).
- Turn the ignition switch on.
- Connect an auxiliary lead [A] to the self-diagnosis terminal [B] for grounding.
- To enter the self-diagnosis dealer mode, ground [C] the self-diagnosis terminal to the frame ground, and then keep it grounded continuously.
- Count the blinks of the yellow engine warning indicator light (LED) to read the service code. Keep the auxiliary lead ground until you finish reading the service code.

#### NOTE

- Keep the self-diagnosis terminal grounded during self-diagnosis, with an auxiliary lead.

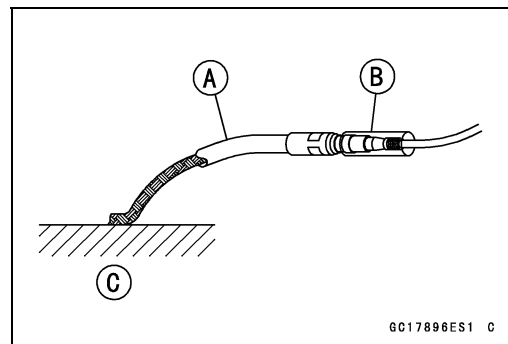

Self-Diagnosis

Self-Diagnosis Flow Chart

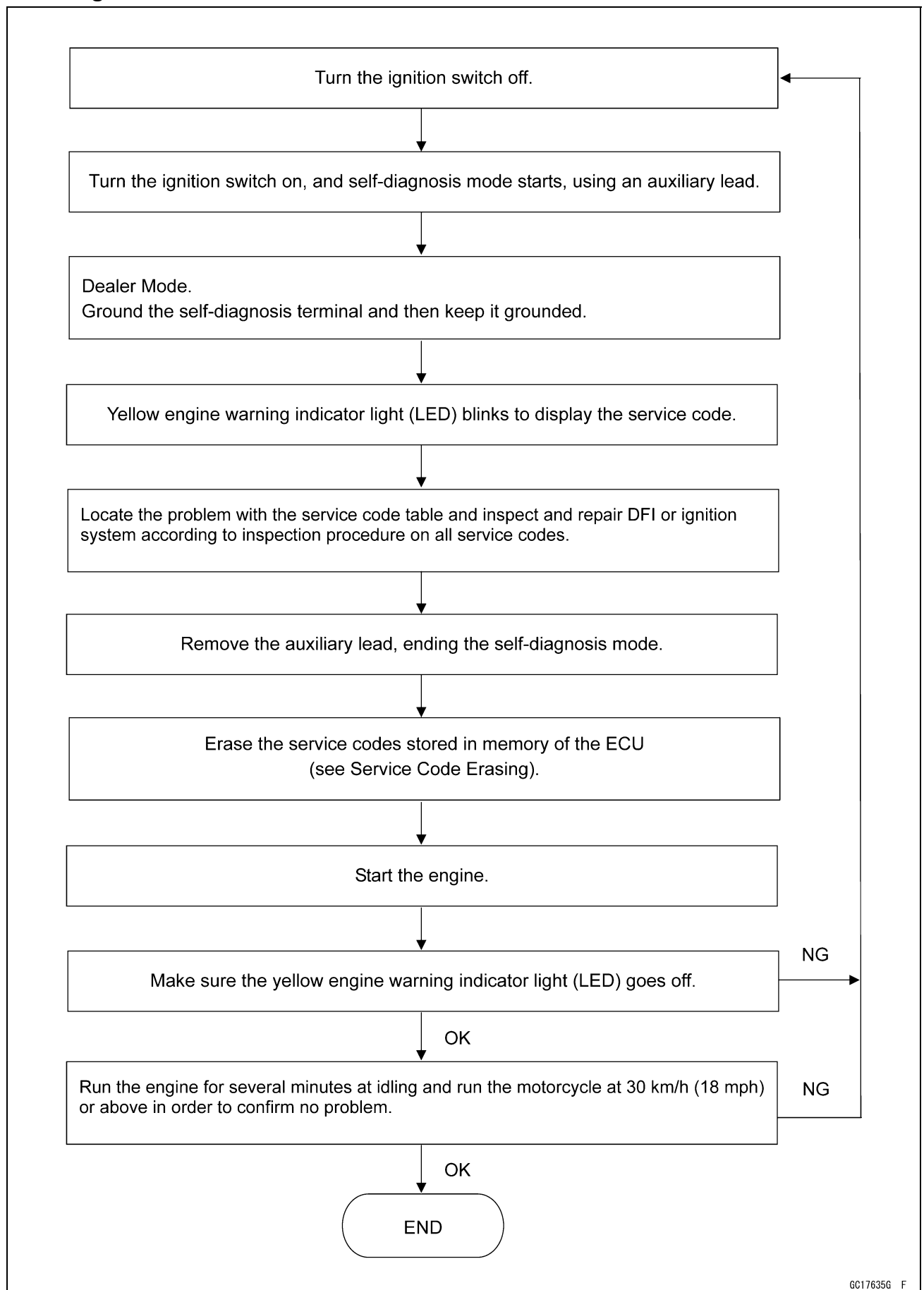

## 3-38 FUEL SYSTEM (DFI)

### Self-Diagnosis

#### Service Code Reading

- Service codes are shown by a series of long and short blinks of the yellow engine warning indicator light (LED) as shown below.
- Read 10th digit and unit digit as the yellow engine warning indicator light (LED) blinks.
- When there are a number of problems, all the service codes can be stored and the display will begin starting from the lowest number service code in the numerical order. Then after completing all codes, the display is repeated until the self-diagnosis terminal is open.
- For example, if two problems occurred in the order of 21, 12, the service codes are displayed from the lowest number in the order listed.  
(12 → 21) → (12 → 21) → . . . (repeated)

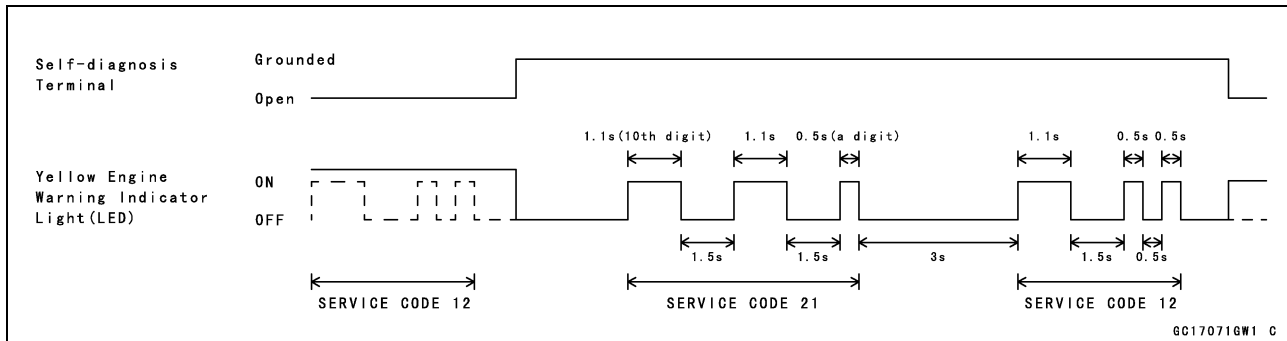















- If the problem is with the following parts, the ECU cannot memorize these problems, the yellow engine warning indicator light (LED) does not go on, and no service codes can be displayed.  
Yellow Engine Warning Indicator Light (LED)  
ECU Power Source Wiring and Ground Wiring (see ECU Power Supply Inspection)

#### Service Code Erasing

- The service codes stored in memory of the ECU can be erased using Kawasaki Diagnostic System (KDS Ver.3).
- ★ If the Kawasaki Diagnostic System (KDS Ver.3) is not available, do the following procedures.
  1. Turn on the ignition switch and start the engine.
  2. Keep the idling speed more than 30 seconds.
  3. Run the vehicle more than 5 minutes at a speed of 40 km/h (25 mph) or more.  
Be sure to keep the engine running during procedures 2 and 3 for more than 10 minutes in total.
  4. Turn the ignition switch off.
  5. Repeat the above procedures 3 times.
  6. Start the engine and check that the yellow engine warning indicator light (LED) goes off.

Self-Diagnosis

Service Code Table

Service Code	DTC (Diagnostic Trouble Code)	Yellow Engine Warning Indicator Light (LED)	Problems
11	P0120		Throttle sensor malfunction, wiring open or short
	P0123		
12	P0105		Intake air pressure sensor malfunction, wiring open or short
	P0106		
	P0107		
13	P0110		Intake air temperature sensor malfunction, wiring open or short
	P0112		
14	P0115		Engine temperature sensor malfunction, wiring open or short
	P0117		
21	P0335		Crankshaft sensor malfunction, wiring open or short
24	P0720		Speed sensor malfunction, wiring open or short
31	C0064		Vehicle-down sensor malfunction, wiring open or short
33	P0130		Oxygen sensor inactivation, wiring open or short
	P0132		
41	P0201		Fuel injector malfunction, wiring open or short
51	P0351		Ignition coil malfunction, wiring open or short
67	P0030		Oxygen sensor heater malfunction, wiring open or short
94	P0170		Fuel supply system trouble, fuel correction valve exceeds a threshold.
1C	P0508		Idle speed control valve actuator malfunction, wiring open or short
	P0511		
	P0519		
3A	P0443		Purge valve malfunction, wiring open or short (CAL Model)

Notes:

- The ECU may be involved in these problems. If all the parts and circuits checked out good, be sure to check the ECU for ground and power supply. If the ground and power supply are checked good, replace the ECU.
- When no service code is displayed, the electrical parts of the DFI system has no fault, and the mechanical parts of the DFI system and the engine are suspect.
- This model adopt hexadecimal notation into a part of the service code (ex.10 = A, 11 = B). Therefore, "one long blink" and "twelve short blinks" expresses the service code "1C."

## 3-40 FUEL SYSTEM (DFI)

### Self-Diagnosis

#### Backups

○The ECU takes the following measures to prevent engine damage when the DFI or ignition system parts have troubles.

Service Codes	Parts or Function	Output Signal Usable Range or Criteria	Backups by ECU
11	Throttle Sensor	Output Voltage 0.2 ~ 4.8 V	If the throttle sensor system fails (the output voltage is out of the usable range, wiring short or open), the ECU locks ignition timing into the ignition timing at closed throttle position and sets the DFI in the D-J method (1).
12	Intake Air Pressure Sensor	Intake Air Pressure (Absolute) Pv = 100 ~ 900 mmHg	If the intake air pressure sensor system fails (the signal is out of the usable range, wiring short or open), the ECU sets the DFI in the $\alpha$ -N method (2).
13	Intake Air Temperature Sensor	Intake Air Temperature Ta = -30 ~ +100°C	If the intake air temperature sensor system fails (the signal is out of the usable range, wiring short or open), the ECU sets Ta at 30°C.
14	Engine Temperature Sensor	Engine Temperature To = -30 ~ +150°C	If the engine temperature sensor system fails (the signal is out of the usable range, wiring short or open), the ECU sets To at 80°C.
21	Crankshaft Sensor	Crankshaft sensor must send 22 signals to the ECU at the 1 cranking.	If the crankshaft sensor fails, the engine stops by itself.
24	Speed Sensor	Speed sensor must send 31 signals to the ECU at the 1 rotation of the output shaft.	If the speed sensor system fails (the signal is missing, wiring short or open) the speedometer shows 0, and the ECU sets the 1st gear position.
31	Vehicle-down Sensor	Output Voltage 0.2 ~ 4.8 V	If the vehicle-down sensor system has failures (the output voltage is out of the usable range, wiring short or open), the ECU shuts off the fuel pump relay, the fuel injector and the ignition system.
33	Oxygen Sensor	The oxygen sensor is active and sensor must send signals (output voltage) continuously to the ECU.	If the oxygen sensor is not activated, the ECU stops the feedback mode of the oxygen sensor.
41	Fuel Injector	In succession pulse is input to ECU.	If the injector break down and does not output for 0.8 seconds or more, wiring short or open, the ECU stops the signal input to injector and the fuel delivery to cylinder is stopped.
51	Ignition Coil	The ECU sends signals (output voltage) continuously to the ignition coil.	If the ignition coil primary winding has failures (no signal, wiring short or open), the ECU shuts off the injector to stop fuel to the cylinder, though the engine keeps running.
67	Oxygen Sensor Heater	The oxygen sensor heater raises temperature of the sensor for its earlier activation.	If the oxygen sensor heater fails (wiring short or open), the ECU stops the current to the heater, and it stops the feedback mode of the oxygen sensor.
94	Fuel Supply System	-	-



**Self-Diagnosis**

<b>Service Codes</b>	<b>Parts or Function</b>	<b>Output Signal Usable Range or Criteria</b>	<b>Backups by ECU</b>
<b>1C</b>	Idle Speed Control Valve Actuator	The actuator operates open and close of the bypass passage by the pulse signal from the ECU.	If the idle speed control valve actuator fails (the signal is out to the usable range, wiring open), the ECU stops the current to the actuator.
<b>3A</b>	Purge Valve (CAL Model)	The purge valve controls the flow of the secondary air by opening and shutting the solenoid valve.	-

**Note:**

- (1): D-J Method: When the engine load is light like at idling or low speed, the ECU determines the injection quantity by calculating from the throttle vacuum (intake air pressure sensor output voltage) and engine speed (crankshaft sensor output voltage). This method is called D-J method.
- (2):  $\alpha$ -N Method: As the engine speed increases, and the engine load turns middle to heavy, the ECU determines the injection quantity by calculating from the throttle opening (throttle sensor output voltage) and the engine speed. This method is called  $\alpha$ -N method.

## 3-42 FUEL SYSTEM (DFI)

### Throttle Sensor (Service Code 11) (DTC P0120, P0123)

The throttle sensor is a rotating variable resistor that change output voltage according to throttle operating. The ECU senses this voltage change and determines fuel injection quantity, and ignition timing according to engine rpm, and throttle opening.

Input Terminal [A]: BL

Output Terminal [B]: Y/W

Ground Terminal [C]: G

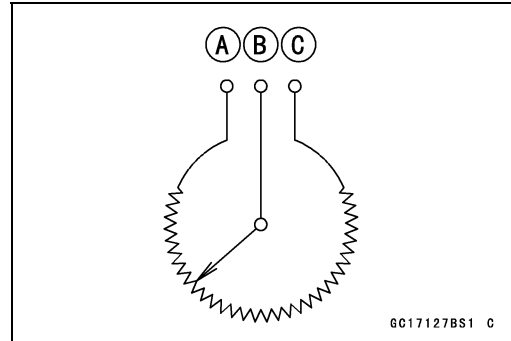

### Throttle Sensor Removal/Adjustment

#### NOTICE

Do not remove or adjust the throttle sensor since it has been adjusted and set with precision at the factory. Never drop the throttle body assy especially on a hard surface. Such a shock to the throttle sensor can damage it.

### Throttle Sensor Input Voltage Inspection

#### NOTE

○Be sure the battery is fully charged.

- Turn the ignition switch off.
- Remove:
  - Left Middle Fairing (see Middle Fairing Removal in the Frame chapter)
- Disconnect the throttle body assy sensors connector and connect the measuring adapters [A] between these connectors as shown.
  - Main Harness [B]
  - Throttle Body Assy Sensors [C]

**Special Tool - Measuring Adapter: 57001-1700**

- Connect a digital meter [D] to the measuring adapter leads.

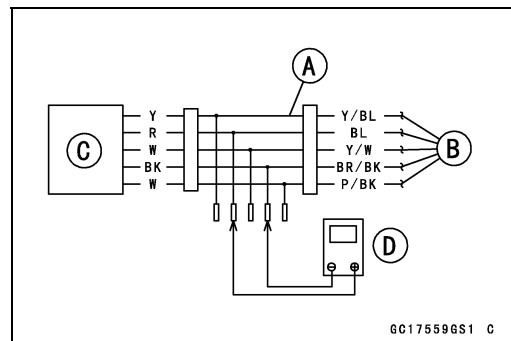
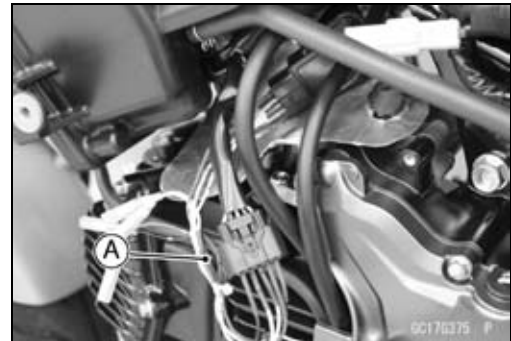

### Throttle Sensor Input Voltage

#### Connections to ECU Connector:

**Digital Meter (+)** → R (main harness BL) lead

**Digital Meter (-)** → BK (main harness BR/BK)lead

- Measure the input voltage with the engine stopped and with the connector joined.
- Turn the ignition switch on.

#### Input Voltage

**Standard: DC 4.75 ~ 5.25 V**

- Turn the ignition switch off.
- ★ If the reading is within the standard, check the output voltage (see Throttle Sensor Output Voltage Inspection).

**Throttle Sensor (Service Code 11) (DTC P0120, P0123)**

★ If the reading is out of the standard, remove the ECU and check the wiring for continuity between main harness connectors.

○ Disconnect the ECU and sensor connectors.

**Wiring Continuity Inspection**

**ECU Connector [A] ↔**

**Throttle Body Assy Sensors Connector [B]**

**BL lead (ECU terminal 13) [C]**

**BR/BK lead (ECU terminal 30) [D]**

★ If the wiring is good, check the ECU for its ground and power supply (see ECU Power Supply Inspection).

★ If the ground and power supply are good, replace the ECU (see ECU Removal/Installation).

**Throttle Sensor Output Voltage Inspection**

● Measure the output voltage at the throttle sensor in the same way as input voltage inspection, note the following.

○ Connect a digital meter [A] to the measuring adapter leads [B].

**Main Harness [C]**

**Throttle Body Assy Sensors [D]**

**Special Tool - Measuring Adapter: 57001-1700**

**Throttle Sensor Output Voltage**

**Connections to ECU Connector:**

**Digital Meter (+) → W (main harness Y/W) lead**

**Digital Meter (-) → BK (main harness BR/BK) lead**

● Start the engine and warm it up thoroughly.

● Check the idle speed to ensure the throttle opening is correct (see Idle Speed Inspection in the Periodic Maintenance chapter).

**Idle Speed**

**Standard: 1 500 ±50 r/min (rpm)**

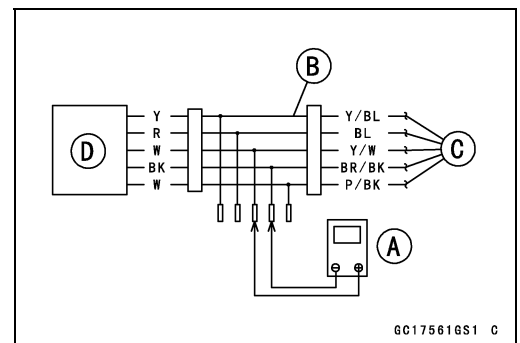
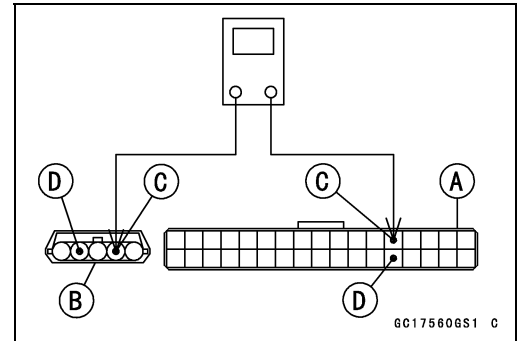

## 3-44 FUEL SYSTEM (DFI)

### Throttle Sensor (Service Code 11) (DTC P0120, P0123)

- Turn the ignition switch off.
- Measure the output voltage with the engine stopped and with the connector joined.
- Turn the ignition switch on.

#### Output Voltage

**Standard:** DC 0.29 ~ 0.71 V at idle throttle opening  
DC 4.13 ~ 4.76 V at full throttle opening (for reference)

#### NOTE

- Open the throttle, confirm the output voltage will be raise.
- The standard voltage refers to the value when the voltage reading at the Input Voltage Inspection shows 5 V exactly.
- When the input voltage reading shows other than 5 V, derive a voltage range as follows.  
*Example:*  
In the case of a input voltage of 4.75 V.  
 $0.29 \times 4.75 \div 5.00 = 0.276 \text{ V}$   
 $0.71 \times 4.75 \div 5.00 = 0.675 \text{ V}$   
Thus, the valid range is 0.276 ~ 0.675 V

- Turn the ignition switch off.
- ★ If the reading is out of the standard, replace the throttle body assy.
- ★ If the reading is within standard, remove the ECU and check the wiring for continuity between main harness connectors.
- Disconnect the ECU and sensor connectors.

#### Wiring Continuity Inspection

**ECU Connector [A]** ↔  
**Throttle Body Assy Sensors Connector [B]**  
**Y/W lead (ECU terminal 28) [C]**  
**BR/BK lead (ECU terminal 30) [D]**

- ★ If the wiring is good, check the ECU for its ground and power supply (see ECU Power Supply Inspection).
- ★ If the ground and power supply are good, replace the ECU (see ECU Removal/Installation).

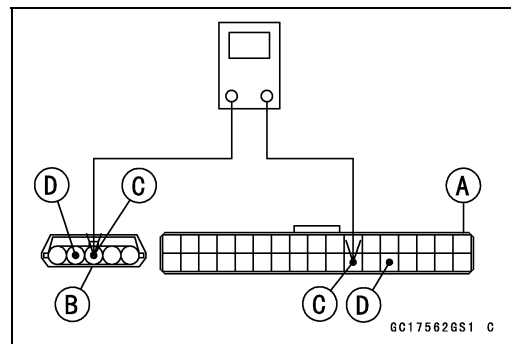

Throttle Sensor (Service Code 11) (DTC P0120, P0123)

Throttle Sensor Circuit

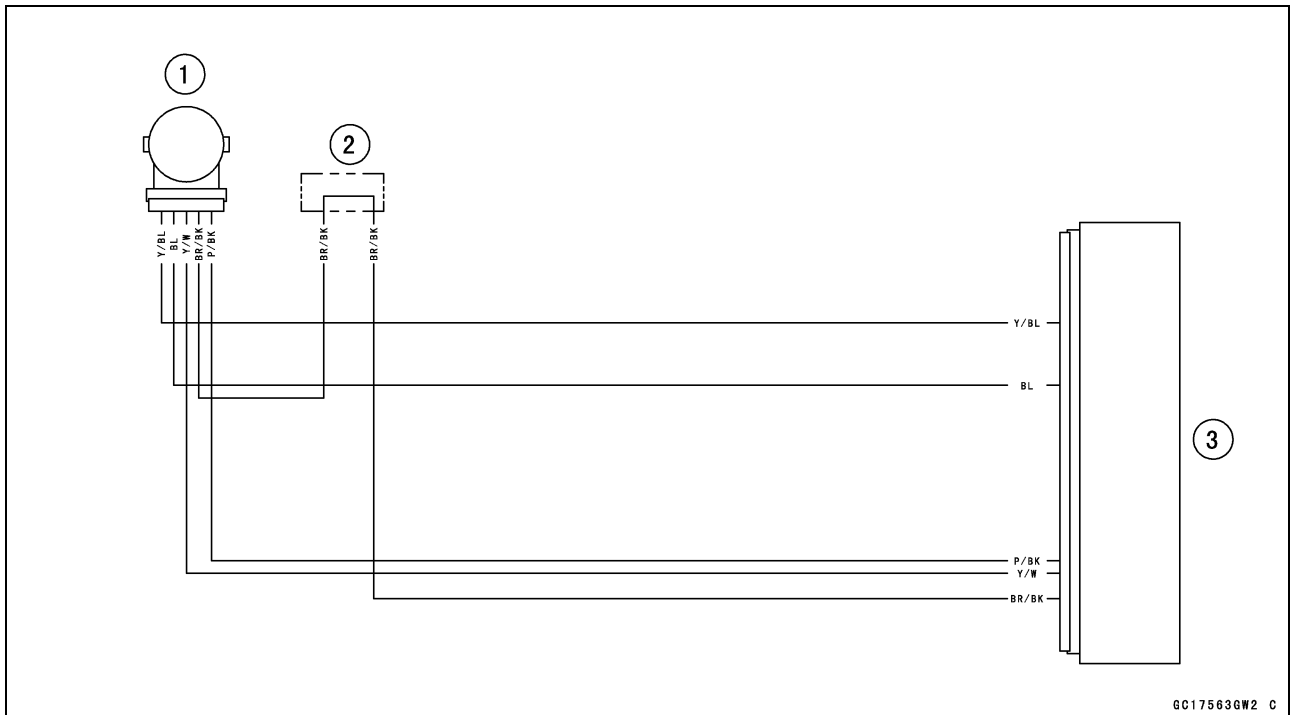

- 1. Throttle Body Assy Sensors
- 2. Water-proof Joint
- 3. ECU

## 3-46 FUEL SYSTEM (DFI)

### Intake Air Pressure Sensor (Service Code 12) (DTC P0105, P0106, P0107)

#### Intake Air Pressure Sensor Removal

##### NOTICE

Do not remove the intake air pressure sensor. Never drop the throttle body assy especially on a hard surface. Such a shock to the intake air pressure sensor can damage it.

#### Intake Air Pressure Sensor Input Voltage Inspection

##### NOTE

○Be sure the battery is fully charged.

- Turn the ignition switch off.
- Remove:
  - Left Middle Fairing (see Middle Fairing Removal in the Frame chapter)
- Disconnect the throttle body assy sensors connector and connect the measuring adapters [A] between these connectors as shown.
  - Main Harness [B]
  - Throttle Body Assy Sensors [C]
- Connect a digital meter [D] to the measuring adapter leads.

**Special Tool - Measuring Adapter: 57001-1700**

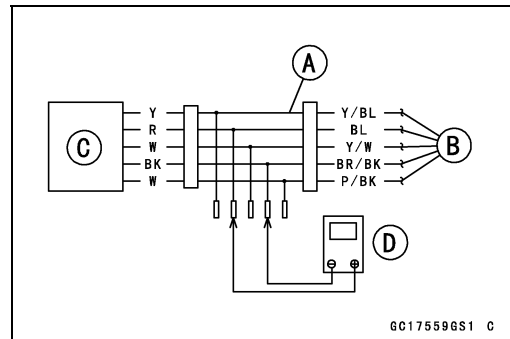
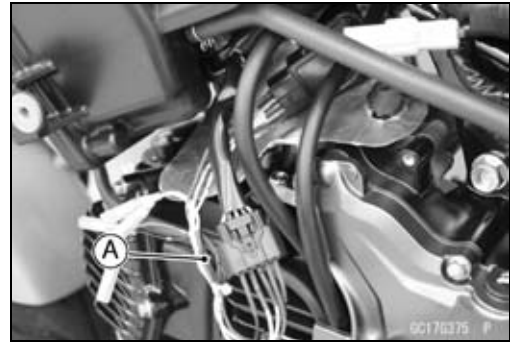

#### Intake Air Pressure Sensor Input Voltage Connections to ECU Connector:

**Digital Meter (+) → R (main harness BL) lead**

**Digital Meter (-) → BK (main harness BR/BK) lead**

- Measure the input voltage with the engine stopped and with the connector joined.
- Turn the ignition switch on.

##### Input Voltage

**Standard: DC 4.75 ~ 5.25 V**

- Turn the ignition switch off.
- ★ If the reading is within the standard, check the output voltage (see Intake Air Pressure Sensor Output Voltage Inspection).

**Intake Air Pressure Sensor (Service Code 12) (DTC P0105, P0106, P0107)**

- ★ If the reading is out of the standard, remove the ECU and check the wiring for continuity between main harness connectors.

○ Disconnect the ECU and sensor connectors.

**Wiring Continuity Inspection**

**ECU Connector [A] ←→**

**Throttle Body Assy Sensors Connector [B]**

**BL lead (ECU terminal 13) [C]**

**BR/BK lead (ECU terminal 30) [D]**

- ★ If the wiring is good, check the ECU for its ground and power supply (see ECU Power Supply Inspection).

- ★ If the ground and power supply are good, replace the ECU (see ECU Removal/Installation).

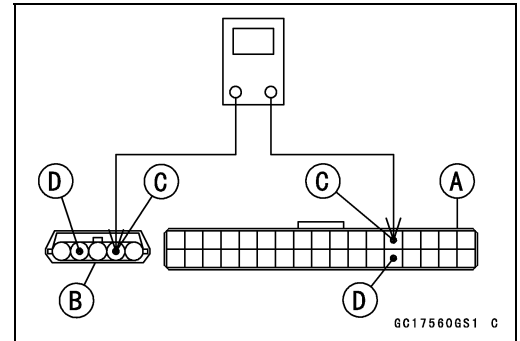

**Intake Air Pressure Sensor Output Voltage Inspection**

- Measure the output voltage at the intake air pressure sensor in the same way as input voltage inspection, note the following.

○ Connect a digital meter [A] to the measuring adapter leads [B].

Main Harness [C]

Throttle Body Assy Sensors [D]

**Special Tool - Measuring Adapter: 57001-1700**

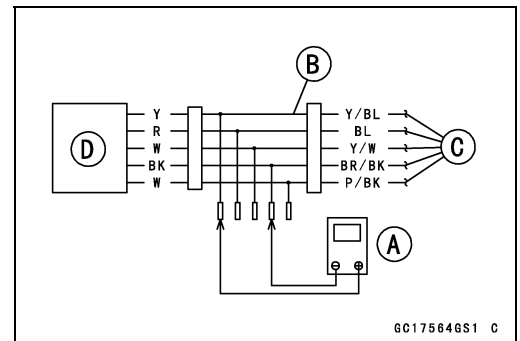

**Intake Air Pressure Sensor Output Voltage**

**Connections to ECU Connector:**

**Digital Meter (+) → Y (main harness Y/BL) lead**

**Digital Meter (-) → BK (main harness BR/BK) lead**

- Measure the output voltage with the engine stopped and with the connector joined.

- Turn the ignition switch on.

**Output Voltage**

**Standard: DC 2.90 V at standard atmospheric pressure (101.32 kPa, 76 cmHg) (for reference)**

**NOTE**

○ The output voltage changes according to local atmospheric pressure.

- Turn the ignition switch off.

- ★ If the reading is much higher or lower than standard, replace the throttle body assy.

# 3-48 FUEL SYSTEM (DFI)

## Intake Air Pressure Sensor (Service Code 12) (DTC P0105, P0106, P0107)

★ If the reading is nearly standard, remove the ECU and check the wiring for continuity between main harness connectors.

○ Disconnect the ECU and sensor connectors.

### Wiring Continuity Inspection

ECU Connector [A] ←→

Throttle Body Assy Sensors Connector [B]

Y/BL lead (ECU terminal 8) [C]

BR/BK lead (ECU terminal 30) [D]

★ If the wiring is good, check the ECU for its ground and power supply (see ECU Power Supply Inspection).

★ If the ground and power supply are good, replace the ECU (see ECU Removal/Installation).

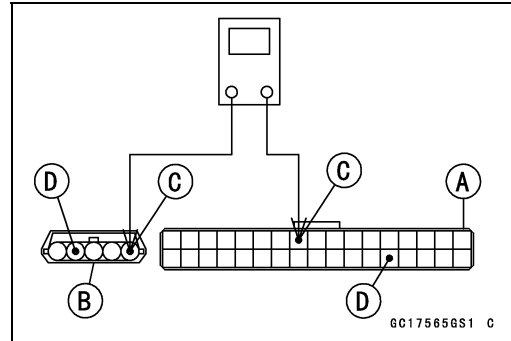

### Intake Air Pressure Sensor Circuit

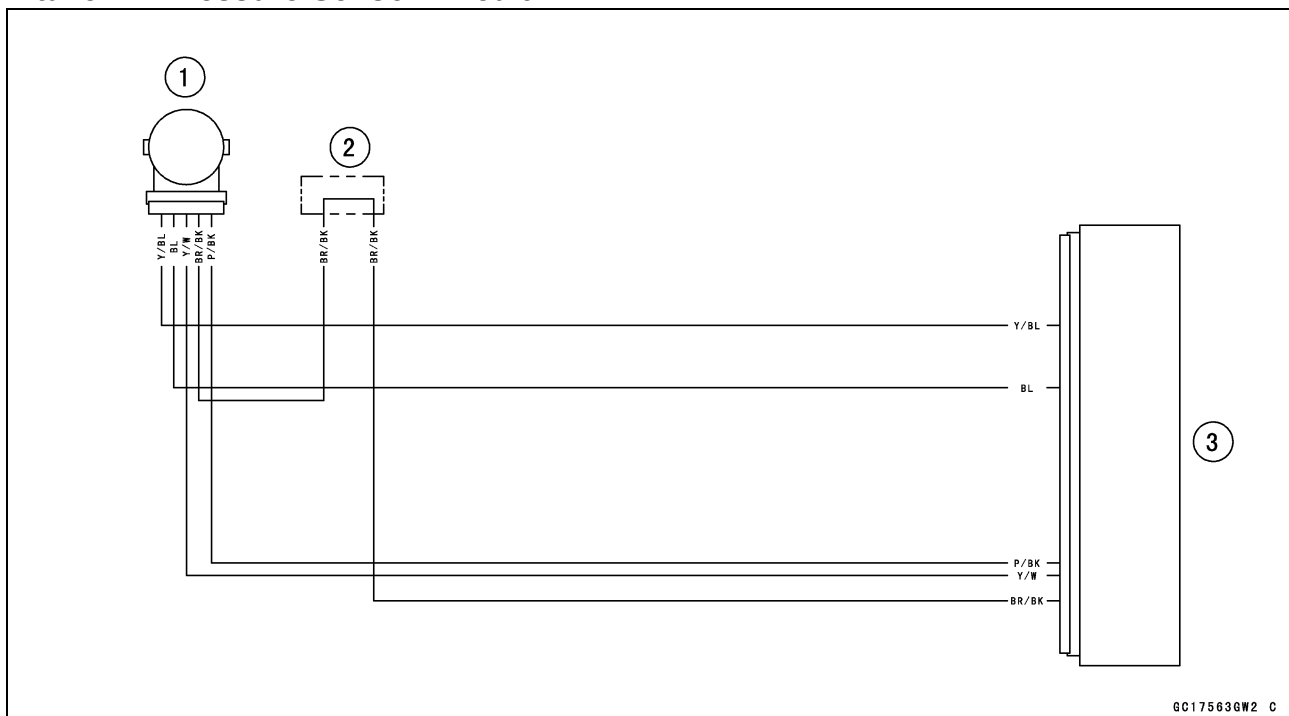

- 1. Throttle Body Assy Sensors
- 2. Water-proof Joint
- 3. ECU



**Intake Air Temperature Sensor (Service Code 13) (DTC P0110, P0112)**

**Intake Air Temperature Sensor Removal**

**NOTICE**

Do not remove the intake air temperature sensor. Never drop the throttle body assy especially on a hard surface. Such a shock to the intake air temperature sensor can damage it.

**Intake Air Temperature Sensor Output Voltage Inspection**

**NOTE**

○Be sure the battery is fully charged.

- Turn the ignition switch off.
- Remove:
  - Left Middle Fairing (see Middle Fairing Removal in the Frame chapter)
- Disconnect the throttle body assy sensors connector and connect the measuring adapters [A] between these connectors as shown.
  - Main Harness [B]
  - Throttle Body Assy Sensors [C]

**Special Tool - Measuring Adapter: 57001-1700**

- Connect a digital meter [D] to the measuring adapter leads.

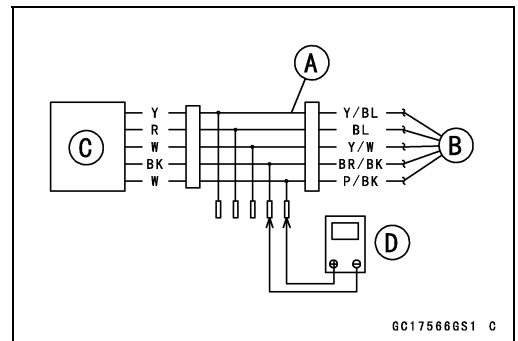
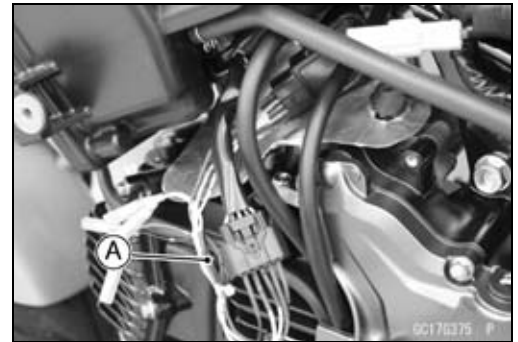

**Intake Air Temperature Sensor Output Voltage Connections to ECU Connector:**

**Digital Meter (+) → W (main harness P/BK) lead**

**Digital Meter (-) → BK (main harness BR/BK) lead**

- Measure the input voltage with the engine stopped and with the connector joined.
- Turn the ignition switch on.

**Output Voltage**

**Standard: About DC 2.80 ~ 3.10 V @20°C (68°F)**

**NOTE**

○The output voltage changes according to the intake air temperature.

- Turn the ignition switch off.
- ★ If the reading is nearly standard, check the ECU for its ground and power supply (see ECU Power Supply Inspection).
- ★ If the ground and power supply are good, replace the ECU (see ECU Removal/Installation).
- ★ If the reading is much higher or lower than standard, check the intake air temperature sensor resistance (see Intake Air Temperature Sensor Resistance Inspection).

# 3-50 FUEL SYSTEM (DFI)

## Intake Air Temperature Sensor (Service Code 13) (DTC P0110, P0112)

### Intake Air Temperature Sensor Resistance Inspection

- Turn the ignition switch off.
- Remove:
  - Left Middle Fairing (see Middle Fairing Removal in the Frame chapter)
- Disconnect the throttle body assy sensors connector and connect a digital meter [A] to the terminal of the throttle body assy sensors [B].

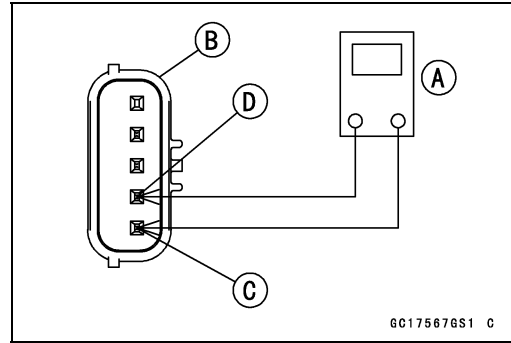

### Intake Air Temperature Sensor Resistance Connections:

P/BK lead [C] ↔ BR/BK lead [D]

Standard: 1.04 ~ 1.23 kΩ @40°C (104°F)  
0.148 ~ 0.162 kΩ @100°C (212°F)

- ★ If the reading is much higher or lower than standard, replace the throttle body assy.
- ★ If the reading is nearly standard, but the problem still exists, replace the ECU (see ECU Removal/Installation).

### Intake Air Temperature Sensor Circuit

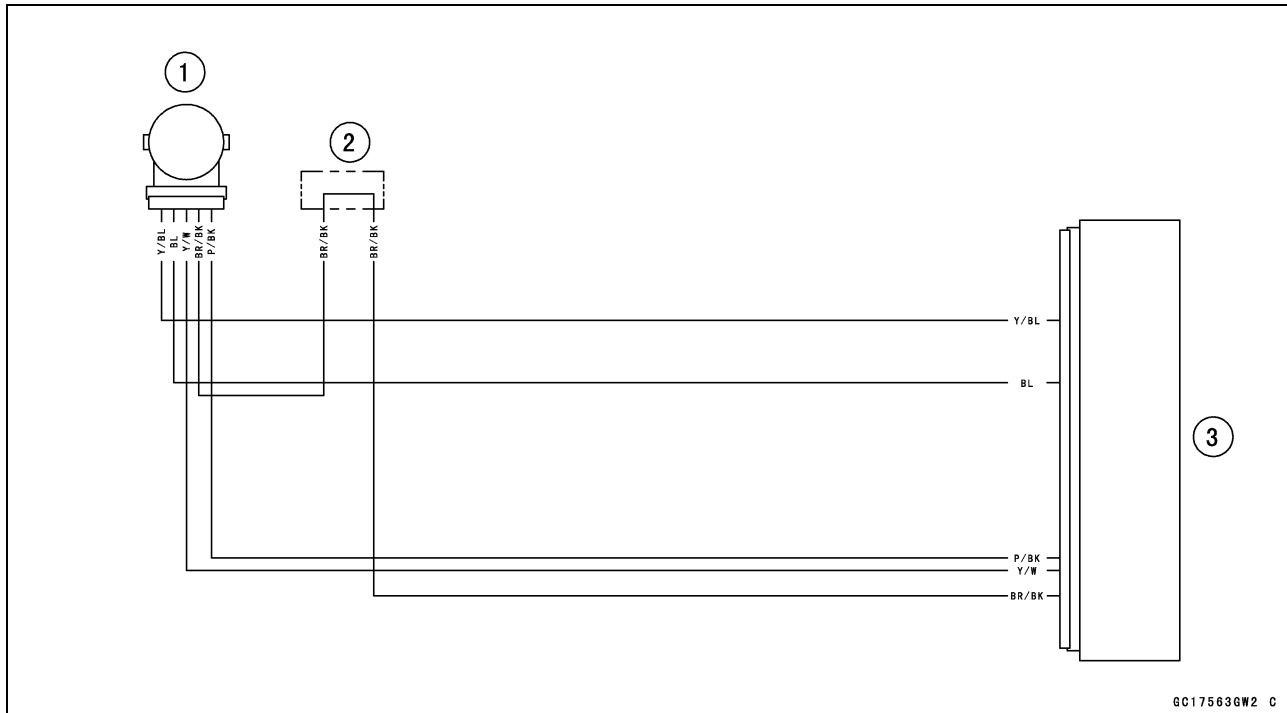

1. Throttle Body Assy Sensors
2. Water-proof Joint
3. ECU

Engine Temperature Sensor (Service Code 14) (DTC P0115, P0117)

Engine Temperature Sensor Removal/Installation

**NOTICE**

Never drop the engine temperature sensor especially on a hard surface. Such a shock to the sensor can damage it.

- Remove:
  - Air Cleaner Housing (see Air Cleaner Housing Removal)
- Disconnect:
  - Engine Temperature Sensor Lead Connector [A]
- Remove:
  - Engine Temperature Sensor [B]
- When installing the band [A], install it as shown.
  - Protector [B]
  - 0 mm [C]
  - 3 ~ 5 mm (0.1 ~ 0.2 in.) [D]
- Tighten:
  - Torque - Engine Temperature Sensor: 9.8 N·m (1.0 kgf·m, 87 in·lb)**
- Run the engine temperature sensor lead correctly (see Cable, Wire, and Hose Routing section in the Appendix chapter).
- Install the removed parts (see appropriate chapters).

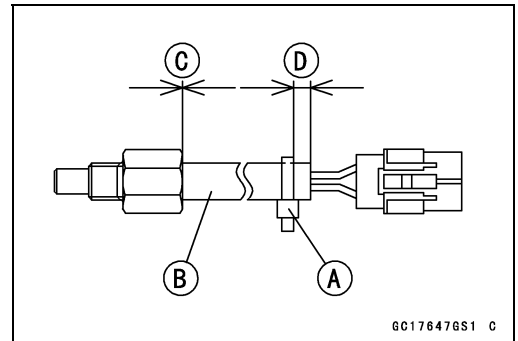
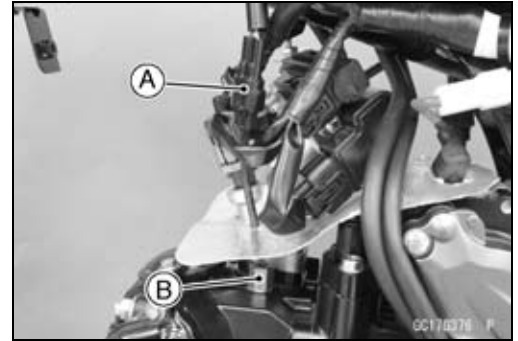

Engine Temperature Sensor Output Voltage Inspection

**NOTE**

○Be sure the battery is fully charged.

- Turn the ignition switch off.
- Remove the air cleaner housing (see Air Cleaner Housing Removal).
- Disconnect the engine temperature sensor lead connector and connect the measuring adapter [A] between these connectors as shown.

Main Harness [B]  
Engine Temperature Sensor [C]

**Special Tool - Measuring Adapter: 57001-1700**

- Connect a digital meter [D] to the measuring adapter leads.

Engine Temperature Sensor Output Voltage

Connections to Adapter:

Digital Meter (+) → R (main harness GY) lead

Digital Meter (-) → BK (main harness BR/BK) lead

- Measure the output voltage with the engine stopped and with the connector joined.
- Turn the ignition switch on.

Output Voltage

Standard: About DC 3.4 ~ 3.8 V @20°C (68°F)

**NOTE**

○The output voltage changes according to the engine temperature.

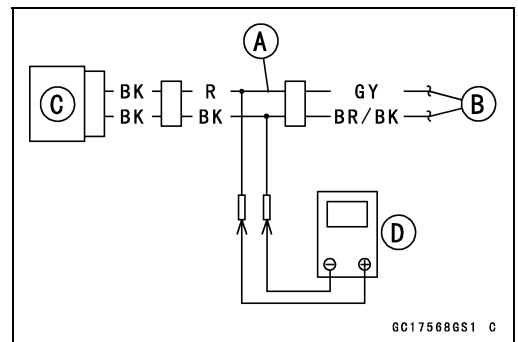
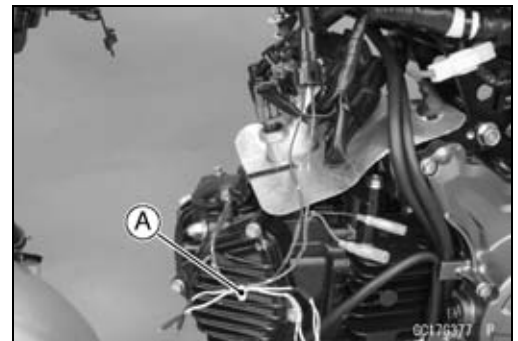

### 3-52 FUEL SYSTEM (DFI)

#### Engine Temperature Sensor (Service Code 14) (DTC P0115, P0117)

- Turn the ignition switch off.
- ★ If the reading is within the standard, check the ECU for its ground and power supply (see ECU Power Supply Inspection).
- ★ If the ground and power supply are good, replace the ECU (see ECU Removal/Installation).
- ★ If the reading is out of the standard, remove the ECU and check the wiring for continuity between main harness connectors.
- Disconnect the ECU and sensor connectors.

#### Wiring Continuity Inspection

ECU Connector [A] ←→

Engine Temperature Sensor Connector [B]

GY lead (ECU terminal 26) [C]

BR/BK lead (ECU terminal 30) [D]

- ★ If the wiring is good, check the engine temperature sensor resistance (see Engine Temperature Sensor Inspection in the Electrical System chapter).
- ★ If the reading is within the standard, but the problem still exists, replace the ECU (see ECU Removal/Installation).

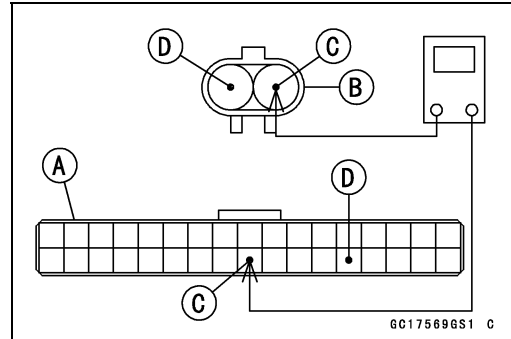

#### Engine Temperature Sensor Resistance Inspection

- Refer to the Engine Temperature Sensor Inspection in the Electrical System chapter.
- ★ If the reading is within the standard, but the problem still exists, replace the ECU (see ECU Removal/Installation).

#### Engine Temperature Sensor Circuit

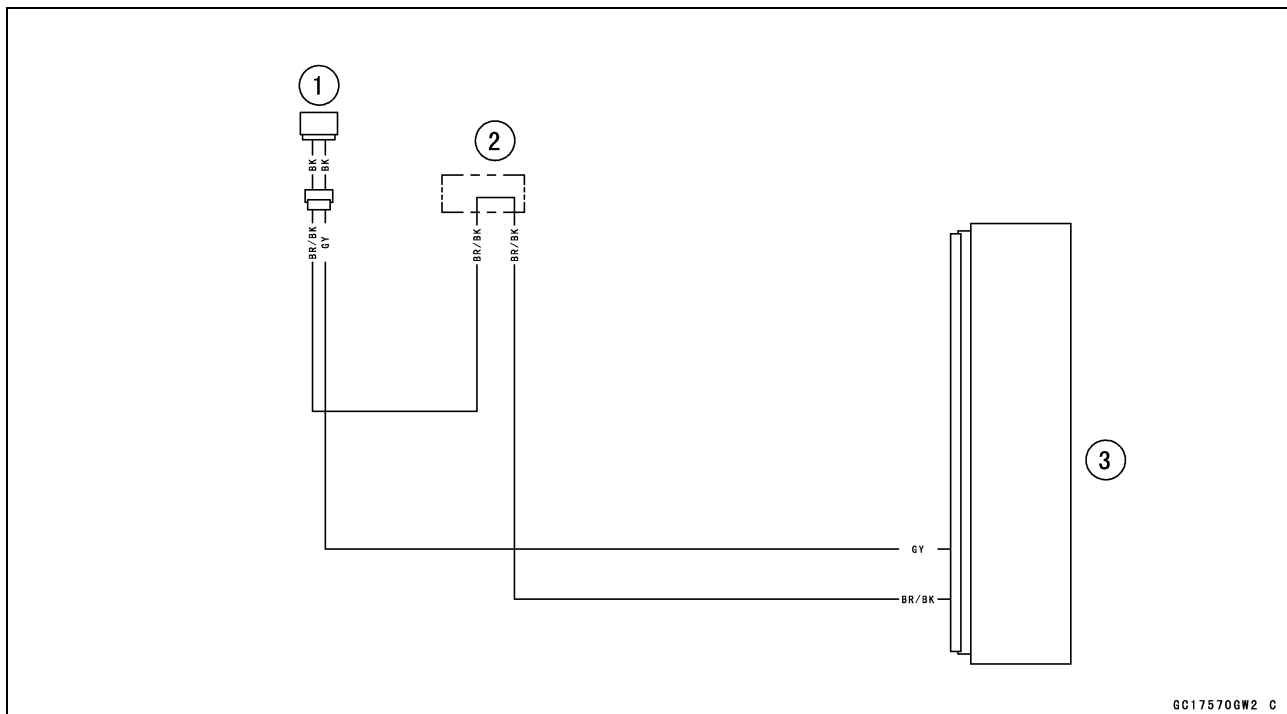

1. Engine Temperature Sensor
2. Water-proof Joint
3. ECU

**Crankshaft Sensor (Service Code 21) (DTC P0335)**

The crankshaft sensor has no power source, and when the engine stops, the crankshaft sensor generates no signals.

**Crankshaft Sensor Removal/Installation**

- Refer to the Crankshaft Sensor Removal/Installation in the Electrical System chapter.

**Crankshaft Sensor Resistance Inspection**

- Refer to the Crankshaft Sensor Inspection in the Electrical System chapter.
- ★ If the reading is within the standard, check the peak voltage (see Crankshaft Sensor Peak Voltage Inspection).

**Crankshaft Sensor Peak Voltage Inspection**

- Refer to the Crankshaft Sensor Peak Voltage Inspection in the Electrical System chapter.
- ★ If the reading is within the standard, remove the ECU and check the wiring for continuity between main harness connectors.
- Disconnect the ECU and sensor connectors.

**Wiring Continuity Inspection**  
ECU Connector [A] ↔

Crankshaft Sensor Connector [B]

BK lead (ECU terminal 22) [C]

BR/BK lead (ECU terminal 30) [D]

- ★ If the wiring is good, check the ECU for its ground and power supply (see ECU Power Supply Inspection).
- ★ If the ground and power supply are good, replace the ECU (see ECU Removal/Installation).

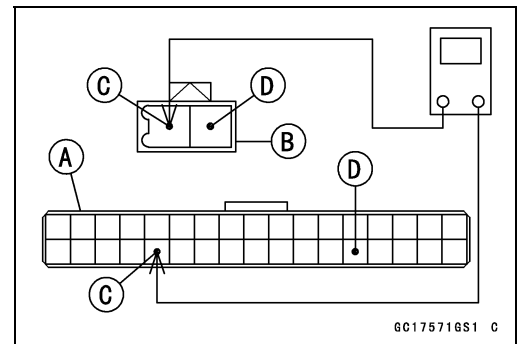

**Crankshaft Sensor Circuit**

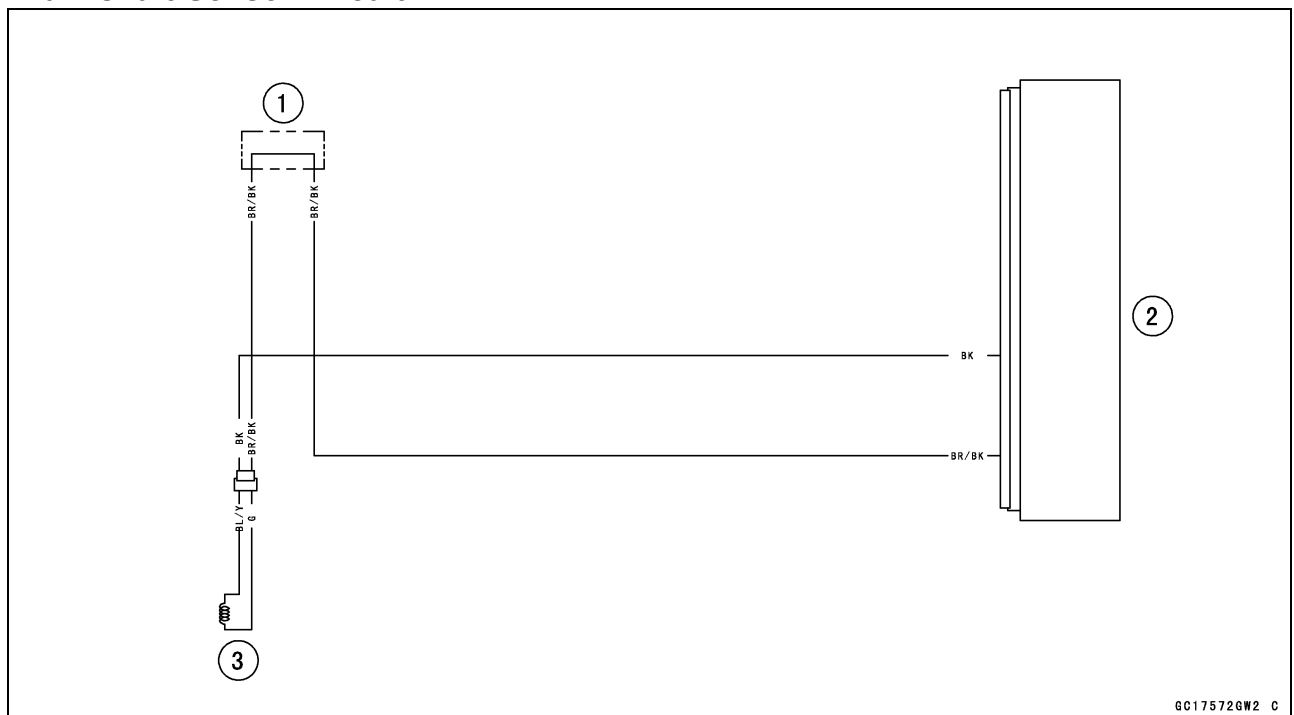

1. Water-proof Joint
2. ECU
3. Crankshaft Sensor

## 3-54 FUEL SYSTEM (DFI)

### Speed Sensor (Service Code 24) (DTC P0720)

#### Speed Sensor Removal/Installation

- Refer to the Speed Sensor Removal/Installation in the Electrical System chapter.

#### Speed Sensor Inspection

- Refer to the Speed Sensor Inspection in the Electrical System chapter.

#### Speed Sensor Input Voltage Inspection

##### NOTE

○ Be sure the battery is fully charged.

- Turn the ignition switch off.
- Remove the speed sensor (see Speed Sensor Removal/Installation in the Electrical System chapter).
- Connect the measuring adapter [A] between the harness connector and speed sensor connector as shown.  
Main Harness [B]  
Speed Sensor [C]

##### Special Tool - Measuring Adapter: 57001-1700

- Connect a digital meter [D] to the measuring adapter leads.

##### Speed Sensor Input Voltage

###### Connections to Adapter:

Digital Meter (+) → R (main harness BR) lead

Digital Meter (-) → BK (main harness BR/BK) lead

- Measure the input voltage with the engine stopped and with the connector joined.
- Turn the ignition switch on.

##### Input Voltage

###### Standard: Battery Voltage

- Turn the ignition switch off.
- ★ If the reading is within the standard, check the output voltage (see Speed Sensor Output Voltage Inspection).
- ★ If the reading is out of the standard, check the wiring for continuity (see Speed Sensor Circuit).
- ★ If there is no continuity, repair or replace the main harness.
- ★ If the wiring is good, check the ECU for its ground and power supply (see ECU Power Supply Inspection).
- ★ If the ground and power supply are good, replace the ECU (see ECU Removal/Installation).

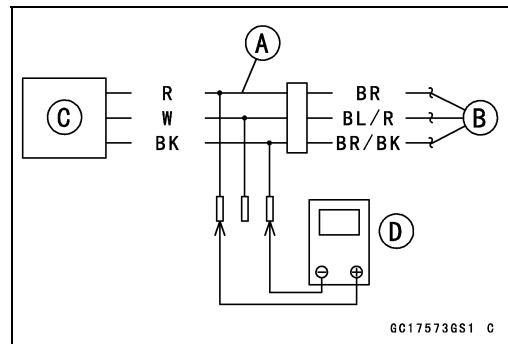
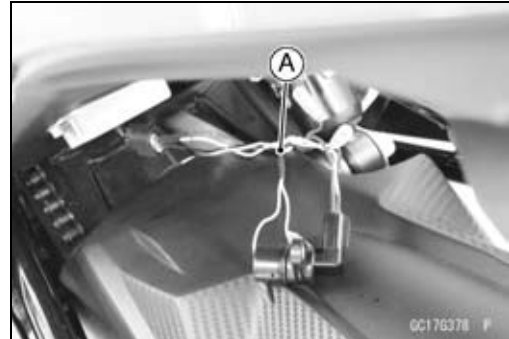

**Speed Sensor (Service Code 24) (DTC P0720)**

**Speed Sensor Output Voltage Inspection**

- Raise the rear wheel off the ground with the stand.
- Measure the output voltage at the speed sensor in the same way as input voltage inspection.
- Disconnect the speed sensor connector and connect the measuring adapter [A] between main harness [B] and speed sensor [C] connectors.
- Temporarily install the speed sensor (see Speed Sensor Removal/Installation in the Electrical System chapter).
- Connect a digital meter [D] to the harness adapter leads.

**Special Tool - Measuring Adapter: 57001-1700**

**Speed Sensor Output Voltage**

**Connections to Adapter:**

**Digital Meter (+) → W (main harness BL/R) lead**

**Digital Meter (-) → BK (main harness BR/BK) lead**

- Measure the output voltage with the engine stopped and with the connector joined.
- Turn the ignition switch on.

**Output Voltage**

**Standard: About DC 0.03 ~ 5 V at rear wheel turning**

**NOTE**

○ Rotate the rear wheel by hand, confirm the output voltage will be raise or lower.

- Turn the ignition switch off.
- ★ If the reading is out of the standard, replace the sensor.
- ★ If the reading is within the standard, remove the ECU and check the wiring for continuity between main harness connectors.
- Disconnect the ECU and sensor connectors.

**Wiring Continuity Inspection**

**ECU Connector [A] ↔**

**Speed Sensor Connector [B]**

**BL/R lead (ECU terminal 10) [C]**

**BR/BK lead (ECU terminal 30) [D]**

- ★ If the wiring is good, check the ECU for its ground and power supply (see ECU Power Supply Inspection).
- ★ If the ground and power supply are good, replace the ECU (see ECU Removal/Installation).

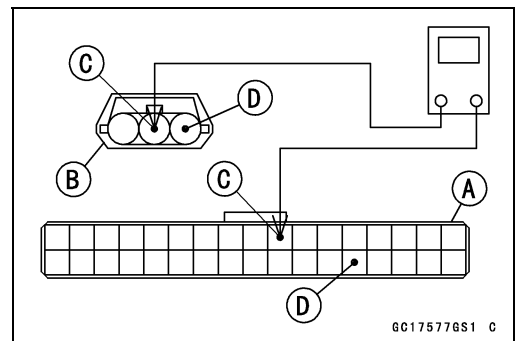
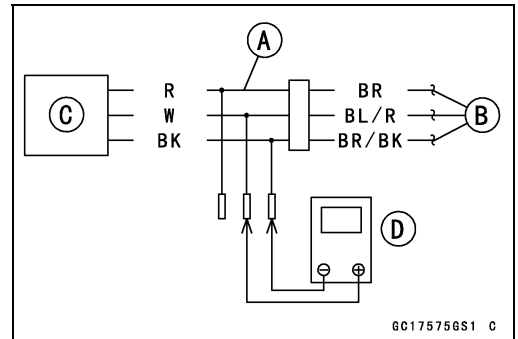

# 3-56 FUEL SYSTEM (DFI)

## Speed Sensor (Service Code 24) (DTC P0720)

### Speed Sensor Circuit

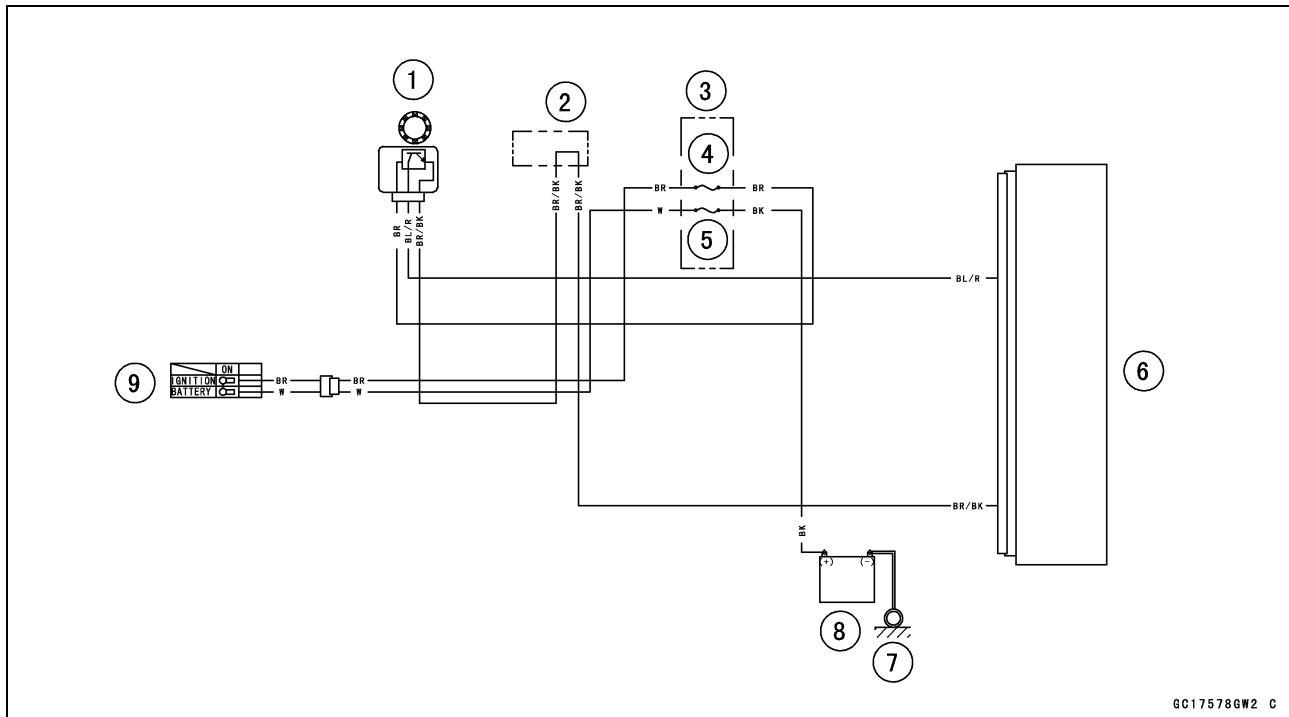

GC175786W2 C

1. Speed Sensor
2. Water-proof Joint
3. Fuse Box
4. Ignition Fuse 10 A
5. Battery Fuse 20 A
6. ECU
7. Engine Ground
8. Battery 12 V 3 Ah
9. Ignition Switch



**Vehicle-down Sensor (Service Code 31) (DTC C0064)**

This sensor has a weight [A] with two magnets inside, and sends a signal to the ECU. But when the motorcycle banks 60 ~ 70° or more to either side (in fact falls down), the weight turns and the signal changes. The ECU senses this change, and stops the fuel pump relay, the fuel injector and the ignition system.

Hall IC [B]

When the motorcycle is down, the ignition switch is left on. If the starter button is pushed, the electric starter turns but the engine does not start. To start the engine again, raise the motorcycle, turn the ignition switch off, and then turn it on.

- Vehicle-down Sensor [A]
- Ground Terminal [B]: BR/BK
- Output Terminal [C]: Y/G
- Power Source Terminal [D]: BL

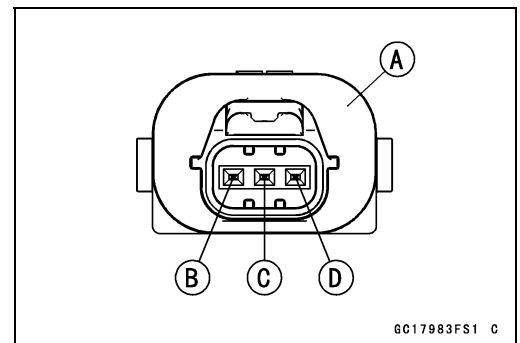
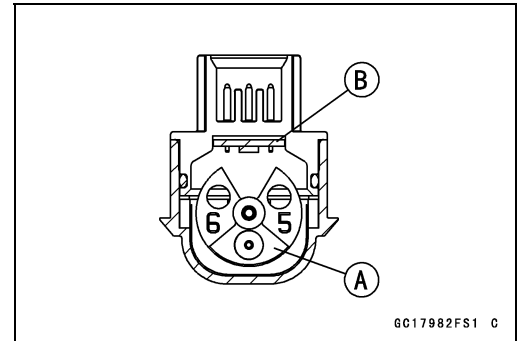

**Vehicle-down Sensor Removal**

**NOTICE**

**Never drop the vehicle-down sensor especially on a hard surface. Such a shock to the sensor can damage it.**

- Remove:
  - Seat (see Seat Removal in the Frame chapter)
- Disconnect the vehicle-down sensor connector [A].
- Remove the vehicle-down sensor [B] from the bracket [C].

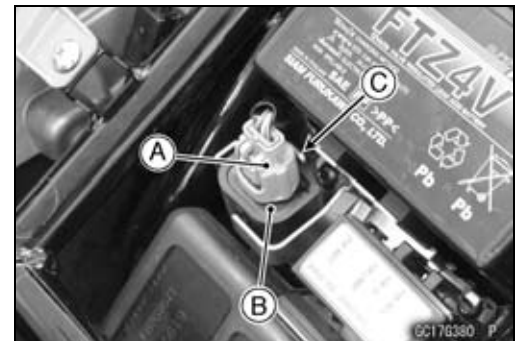

**Vehicle-down Sensor Installation**

- The UP mark [A] of the sensor should face upward.

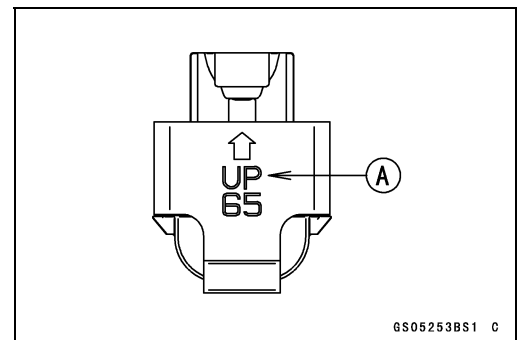

## 3-58 FUEL SYSTEM (DFI)

### Vehicle-down Sensor (Service Code 31) (DTC C0064)

#### **⚠ WARNING**

Incorrect installation of the vehicle-down sensor could cause sudden loss of engine power. The rider could lose balance during certain riding situations for an accident resulting in injury or death. Ensure that the vehicle-down sensor is held in place by the sensor bracket.

- Install the vehicle-down sensor on the bracket [A] securely.
- Connect the vehicle-down sensor connector.
- Install the seat (see Seat Installation on the Frame chapters).



#### **Vehicle-down Sensor Input Voltage Inspection**

##### **NOTE**

○ Be sure the battery is fully charged.

- Turn the ignition switch off.
- Disconnect the vehicle-down sensor connector and connect the measuring adapter [A] between these connectors as shown.

Main Harness [B]

Vehicle-down Sensor [C]

**Special Tool - Measuring Adapter: 57001-1700**

- Connect a digital meter [D] to the measuring adapter leads.

##### **Vehicle-down Sensor Input Voltage**

###### **Connections to Adapter:**

**Digital Meter (+) → R (sensor BL) lead**

**Digital Meter (-) → BK (sensor BR/BK) lead**

- Measure the input voltage with the engine stopped and with the connector joined.
- Turn the ignition switch on.

##### **Input Voltage**

**Standard: DC 4.75 ~ 5.25 V**

- Turn the ignition switch off.
- ★ If the reading is within the standard, check the output voltage (see Vehicle-down Sensor Output Voltage Inspection).

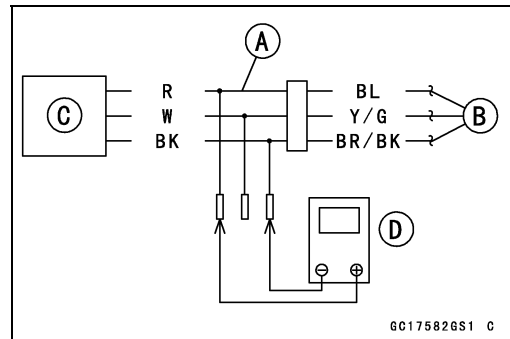

**Vehicle-down Sensor (Service Code 31) (DTC C0064)**

★ If the reading is out of the standard, remove the ECU and check the wiring for continuity between main harness connectors.

○ Disconnect the ECU and sensor connectors.

**Wiring Continuity Inspection**

**ECU Connector [A] ↔**

**Vehicle-down Sensor Connector [B]**

**BL lead (ECU terminal 13) [C]**

**BR/BK lead (ECU terminal 30) [D]**

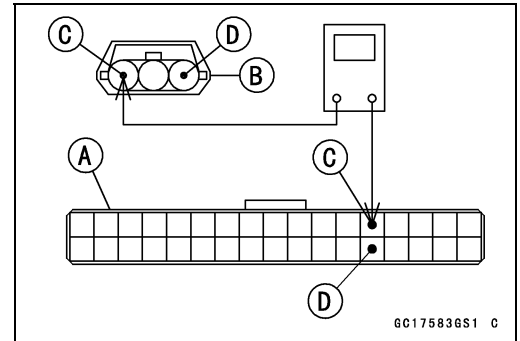

★ If the wiring is good, check the ECU for its ground and power supply (see ECU Power Supply Inspection).

★ If the ground and power supply are good, replace the ECU (see ECU Removal/Installation).

**Vehicle-down Sensor Output Voltage Inspection**

● Remove the vehicle-down sensor (see Vehicle-down Sensor Removal).

● Connect the measuring adapter [A] between these connectors as shown.

Main Harness [B]

Vehicle-down Sensor [C]

**Special Tool - Measuring Adapter: 57001-1700**

● Connect a digital meter [D] to the measuring adapter leads.



**Vehicle-down Sensor Output Voltage**

**Connections to Adapter:**

**Digital Meter (+) → W (sensor Y/G) lead**

**Digital Meter (-) → BK (sensor BR/BK) lead**

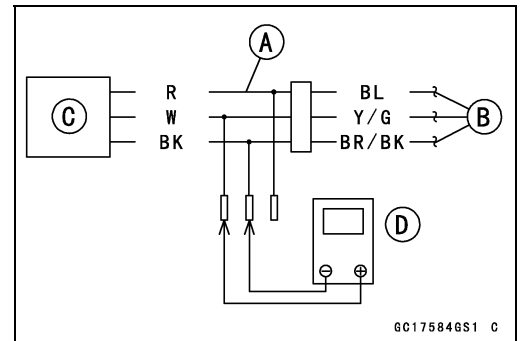

## 3-60 FUEL SYSTEM (DFI)

### Vehicle-down Sensor (Service Code 31) (DTC C0064)

- Hold the sensor vertically.
- Measure the output voltage with the engine stopped and with the connector joined.
- Turn the ignition switch on.
- Tilt the sensor 60 ~ 70° or more [A] right or left, then hold the sensor almost vertical with the arrow mark pointed up [B], and measure the output voltage.

#### Output Voltage

**Standard:** With sensor tilted 60 ~ 70° or more right or left: DC 0.65 ~ 1.35 V

With sensor arrow mark pointed up: DC 3.55 ~ 4.45 V

- Turn the ignition switch off.
- ★ If the reading is out of the standard, replace the sensor.

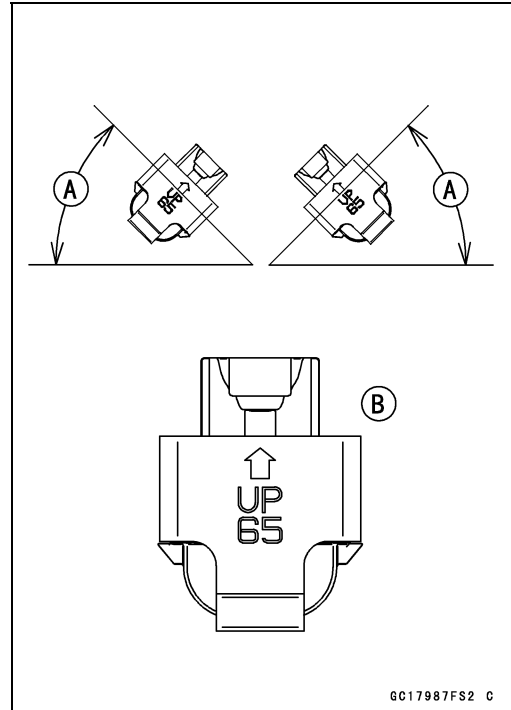

- ★ If the reading is within the standard, remove the ECU and check the wiring for continuity between main harness connectors.

○ Disconnect the ECU and sensor connectors.

#### Wiring Continuity Inspection

**ECU Connector [A]** ←→

**Vehicle-down Sensor Connector [B]**

**Y/G lead (ECU terminal 14) [C]**

**BR/BK lead (ECU terminal 30) [D]**

- ★ If the wiring is good, check the ECU for its ground and power supply (see ECU Power Supply Inspection).
- ★ If the ground and power supply are good, replace the ECU (see ECU Removal/Installation).

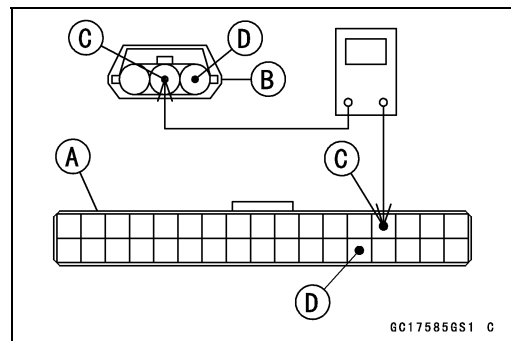

Vehicle-down Sensor (Service Code 31) (DTC C0064)

Vehicle-down Sensor Circuit

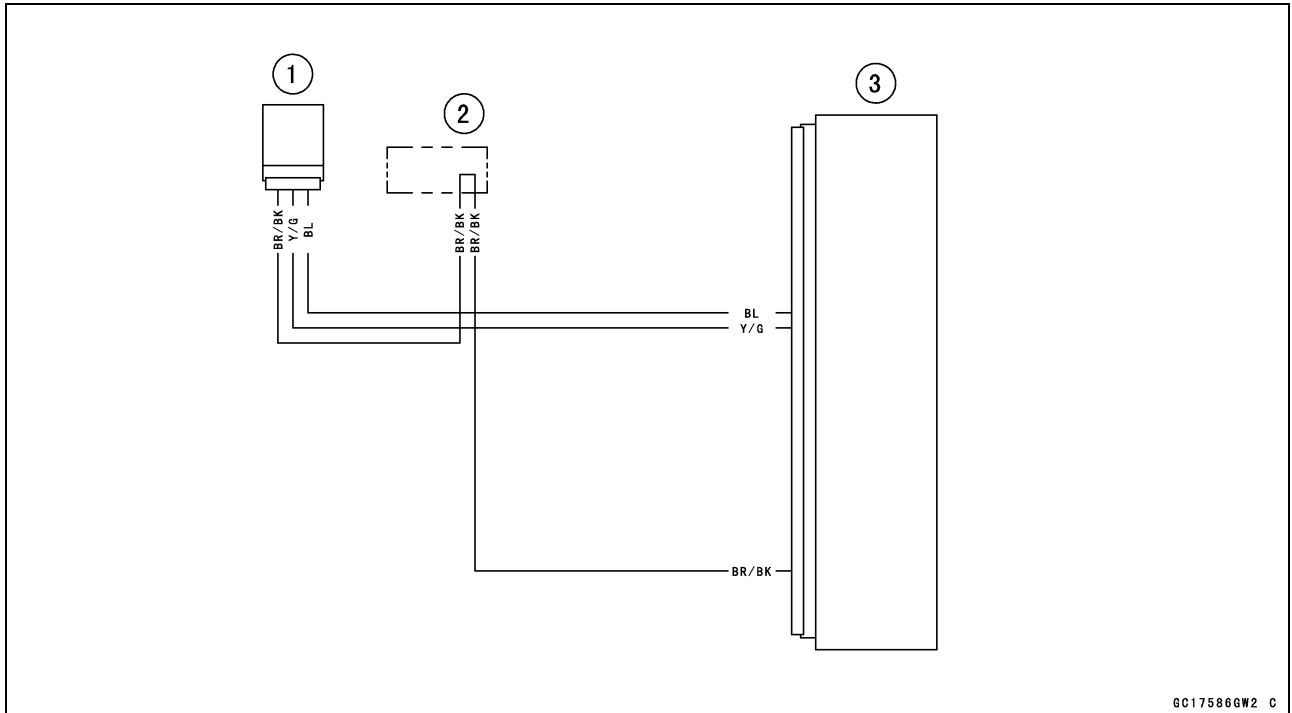

- 1. Vehicle-down Sensor
- 2. Water-proof Joint
- 3. ECU

## 3-62 FUEL SYSTEM (DFI)

### Oxygen Sensor - not activated (Service Code 33) (DTC P0130, P0132)

#### Oxygen Sensor Removal/Installation

- Refer to the Oxygen Sensor Removal/Installation in the Electrical System chapter.

#### Oxygen Sensor Inspection

- Warm up the engine thoroughly until the idle speed steadies.
- At first the engine will run fast to decrease warm up time (fast idle).
- Gradually the fast idle will lower to a certain RPM automatically.
- Turn the ignition switch off.
- Remove:
  - Right Side/Frame Cover (see Side/Frame Cover Removal in the Frame chapter)
- Remove the oxygen sensor lead connector [A] from the bracket.



- Disconnect the oxygen sensor lead connector and connect the measuring adapter [A] between these connectors as shown.
  - Main Harness [B]
  - Oxygen Sensor [C]



#### Special Tool - Measuring Adapter: 57001-1700

- Connect a digital meter [D] to the measuring adapter leads.

#### Oxygen Sensor Output Voltage

##### Connections to Adapter:

Digital Meter (+) → R (sensor BK) lead

Digital Meter (-) → BK (sensor GY) lead

- Start the engine.
- Measure the output voltage with the connector joined.

#### Output Voltage (Reference Value)

Standard: (Rich) DC 0.8 V or more  
(Lean) DC 0.24 V or less

#### NOTE

- Open or close the throttle grip, confirm the output voltage will be raise or lower.

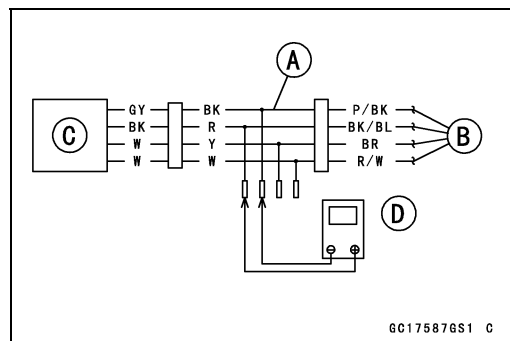

Oxygen Sensor - not activated (Service Code 33) (DTC P0130, P0132)

★ If the value does not change, remove the ECU and check the wiring for continuity between main harness connectors.

○ Disconnect the ECU and sensor connectors.

**Wiring Continuity Inspection**

**ECU Connector [A]** ←→

**Oxygen Sensor Connector [B]**

**BK/BL lead (ECU terminal 12) [C]**

**P/BK lead (ECU terminal 29) [D]**

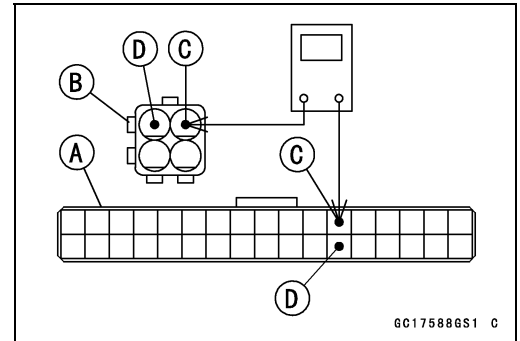

- ★ If the wiring is good, replace the sensor.
- ★ If the reading is within the standard, check the ECU for its ground and power supply (see ECU Power Supply Inspection).
- ★ If the ground and power supply are good, replace the ECU (see ECU Removal/Installation).

**Oxygen Sensor Circuit**

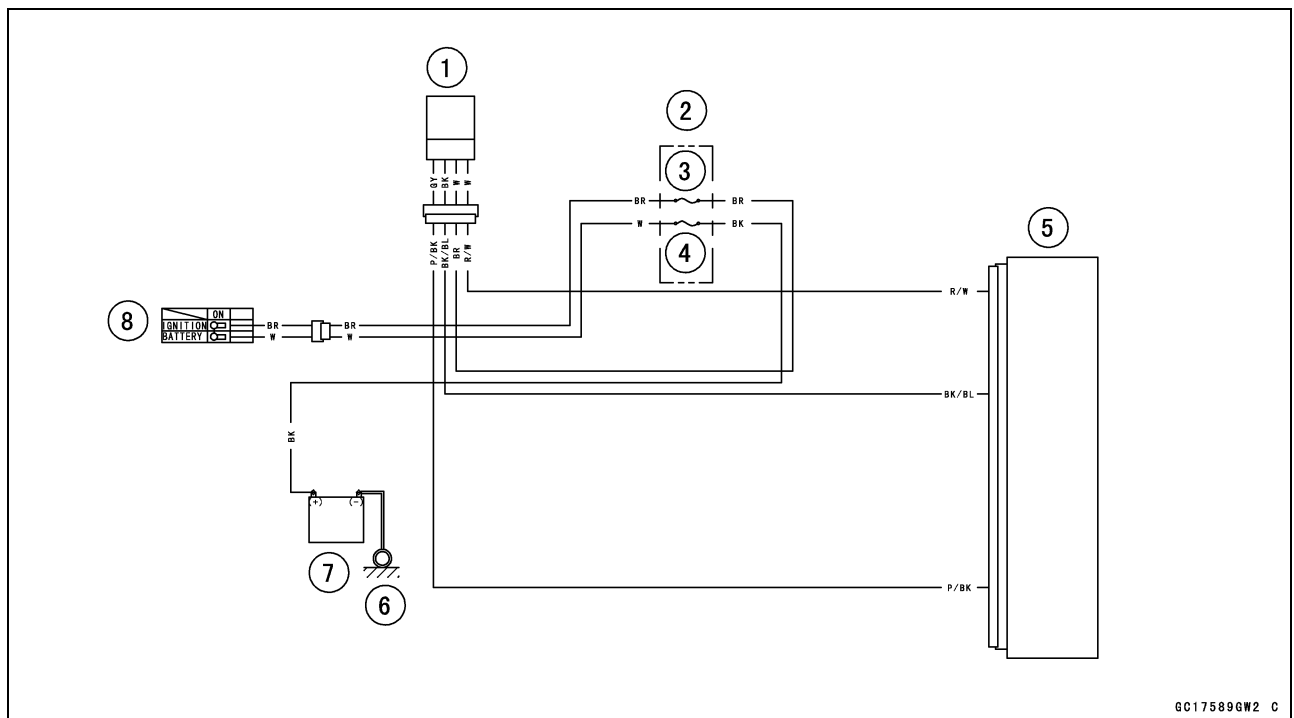

1. Oxygen Sensor
2. Fuse Box
3. Ignition Fuse 10 A
4. Battery Fuse 20 A
5. ECU
6. Engine Ground
7. Battery 12 V 3 Ah
8. Ignition Switch

## 3-64 FUEL SYSTEM (DFI)

### Fuel Injector (Service Code 41) (DTC P0201)

#### Fuel Injector Removal

#### **⚠ WARNING**

Gasoline is extremely flammable and can be explosive under certain conditions, creating the potential for serious burns. Make sure the area is well ventilated and free from any source of flame or sparks; this includes any appliance with a pilot light. Do not smoke. Turn the ignition switch off. Be prepared for fuel spillage; any spilled fuel must be completely wiped up immediately.

#### **NOTICE**

Never drop the fuel injector especially on a hard surface. Such a shock to the injector can damage it.

- Remove:
  - Air Cleaner Housing (see Air Cleaner Housing Removal)
- Disconnect:
  - Fuel Injector Connector [A]
  - Fuel Hose [B] (see Fuel Hose Replacement in the Periodic Maintenance chapter)
- Remove:
  - Delivery Pipe Mounting Bolt [A]
  - Delivery Pipe with Fuel Injector [B]

#### **NOTE**

○Do not damage the insertion portion of the fuel injector when it is pulled out from the throttle body assy.

- Remove the fuel injector [A] from the delivery pipe [B].

#### **NOTE**

○Do not damage the insertion portion of the fuel injector when it is pulled out from the delivery pipe.

#### **NOTICE**

Never drop the fuel injector especially on a hard surface. Such a shock to the injector can damage it.

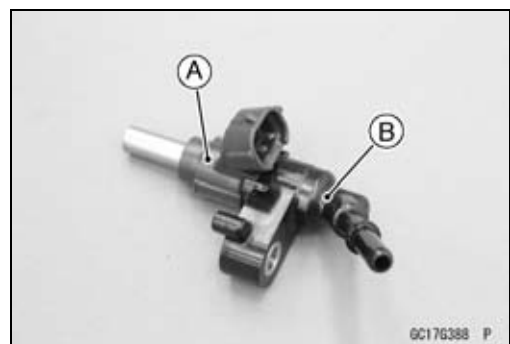
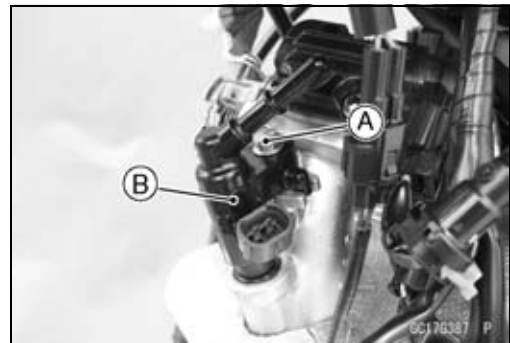
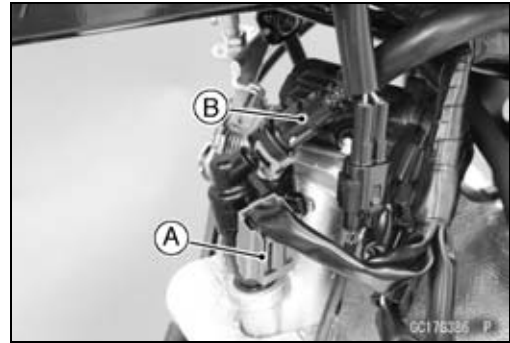



Fuel Injector (Service Code 41) (DTC P0201)

**Fuel Injector Installation**

- Replace the O-ring [A] of the fuel injector [B] with a new one.
- Apply engine oil to the new O-ring.

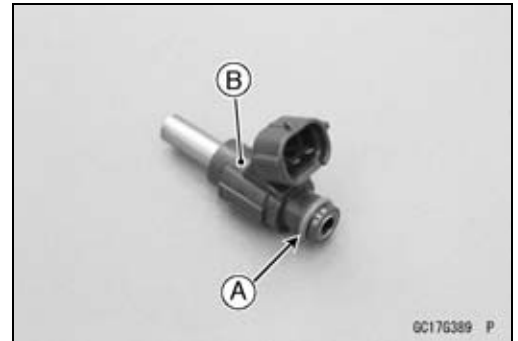

- Insert the fuel injector [A] into the delivery pipe [B] as shown.

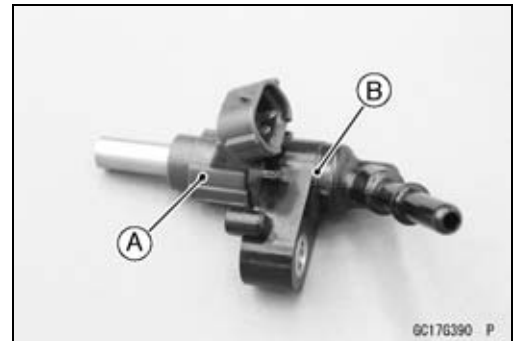

- Replace the dust seal [A] with a new one.
- Apply engine oil to the new dust seal.

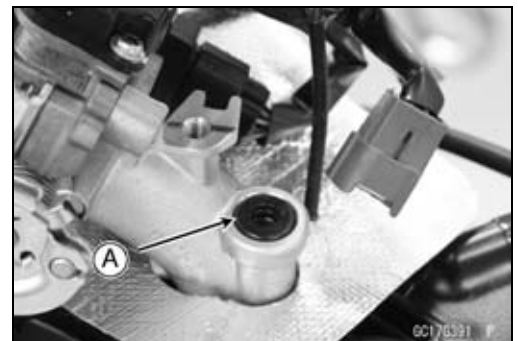

- Install the fuel injector [A] to the intake pipe.
- Fit the projection [B] of the delivery pipe to the groove [C] of the intake pipe.
- Tighten:
  - Torque - Delivery Pipe Mounting Bolt [D]: 5.2 N·m (0.53 kgf·m, 46 in·lb)**
- Install the removed parts (see appropriate chapters).

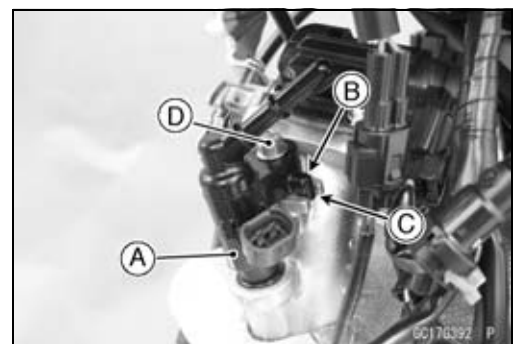

## 3-66 FUEL SYSTEM (DFI)

### Fuel Injector (Service Code 41) (DTC P0201)

#### **Fuel Injector Audible Inspection**

##### **NOTE**

○Be sure the battery is fully charged.

- Remove the left side/frame cover (see Side/Frame Cover Removal in the Frame chapter).
- Start the engine, and let it idle.
- Apply the flat tip screwdriver [A] to the fuel injector [B]. Put the grip end onto your ear, and listen whether the fuel injector is clicking or not.
- A sound scope can also be used.
- The click interval becomes shorter as the engine speed rises.
- ★If the fuel injector click at a regular intervals, the fuel injector is normal.
- Turn the ignition switch off.
- ★If the fuel injector does not click, check the fuel injector resistance (see Fuel Injector Resistance Inspection).

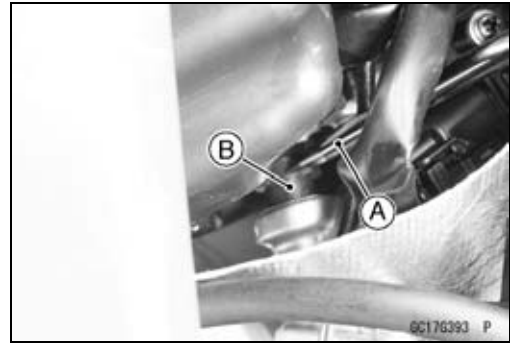

#### **Fuel Injector Resistance Inspection**

- Remove:
  - Air Cleaner Housing (see Air Cleaning Housing Removal).
- Disconnect the fuel injector connector [A].

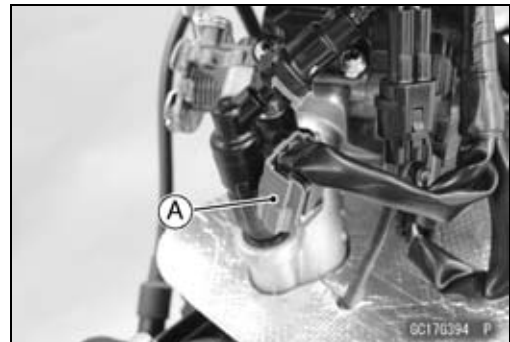

- Connect a digital meter to the terminals [A] of the fuel injector.
- Measure the fuel injector resistance.

##### **Fuel Injector Resistance**

**Standard: About 11.5 ~ 12.5  $\Omega$  @20°C (68°F)**

- ★If the reading is out of the standard, replace the fuel injector.
- ★If the reading is within the standard, check the power source voltage (see Fuel Injector Power Source Voltage Inspection).



**Fuel Injector (Service Code 41) (DTC P0201)**

**Fuel Injector Power Source Voltage Inspection**

**NOTE**

○Be sure the battery is fully charged.

- Turn the ignition switch off.
- Remove the air cleaner housing (see Air Cleaner Housing Removal).
- Disconnect the fuel injector connector and connect the measuring adapter [A] between these connectors as shown.  
Main Harness [B]  
Fuel Injector [C]



**Special Tool - Measuring Adapter: 57001-1700**

- Connect a digital meter [D] to the measuring adapter leads.

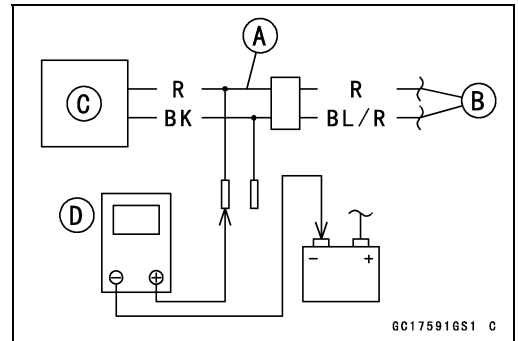

**Fuel Injector Power Source Voltage**

**Connections to Adapter:**

**Digital Meter (+) → R (injector R) lead**

**Digital Meter (-) → Battery (-) terminal**

- Measure the power source voltage with the engine stopped.
- Turn the engine stop switch to run position.
- Turn the ignition switch on.

**Power Source Voltage**

**Standard: Battery Voltage**

- Turn the ignition switch off.
- ★ If the voltage is out of the standard, check the power supply wiring (see Fuel Injector Circuit).
- ★ If the reading is within the standard, check the output voltage (see Fuel Injector Output Voltage Inspection).

**Fuel Injector Output Voltage Inspection**

**NOTE**

○Be sure the battery is fully charged.

- Turn the ignition switch off.
- Remove:  
ECU (see ECU Removal)  
Left Side/Frame Cover (see Side/Frame Cover Removal in the Frame chapter)
- Pull out the ECU connector [A] to the outside of the frame.
- Connect the ECU connector.



## 3-68 FUEL SYSTEM (DFI)

### Fuel Injector (Service Code 41) (DTC P0201)

- Connect a digital meter [A] to the connector [B] with the needle adapter set.

**Special Tool - Needle Adapter Set: 57001-1457**

#### Fuel Injector Output Voltage

**Connections to ECU Connector:**

**Digital Meter (+) → BL/R lead (ECU terminal 20)**

**Digital Meter (-) → Battery (-) terminal**

- Measure the output voltage with the engine stopped and with the connector joined.
- Turn the engine stop switch to run position.
- Turn the ignition switch on.

#### Output Voltage

**Standard: Battery Voltage**

- Turn the ignition switch off.
  - ★ If the reading is in specification, check the ECU for its ground and power supply (see ECU Power Supply Inspection).
  - ★ If the ground and power supply are good, replace the ECU (see ECU Removal/Installation).
  - ★ If the reading is out of the specification, remove the ECU and check the wiring for continuity between main harness connectors.
- Disconnect the ECU and fuel injector connectors.

#### Wiring Continuity Inspection

**ECU Connector [A] ←→**

**Fuel Injector Connector [B]**

**BL/R lead (ECU terminal 20) [C]**

- ★ If the wiring is good, check the ECU for its ground and power supply (see ECU Power Supply Inspection).
- ★ If the ground and power supply are good, replace the ECU (see ECU Removal/Installation).

#### Fuel Injector Fuel Line Inspection

- Remove:
  - Fuel Hose (see Fuel Hose Replacement in the Periodic Maintenance chapter)
- Be sure to place a piece of cloth around the fuel outlet pipe of the fuel pump and the delivery pipe.

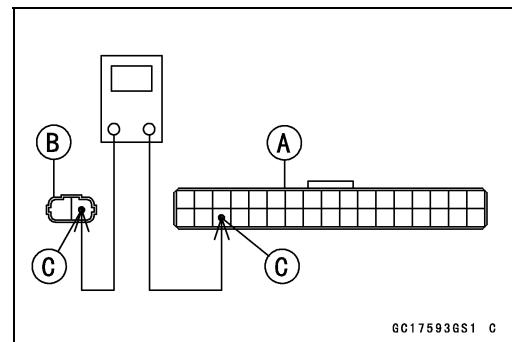
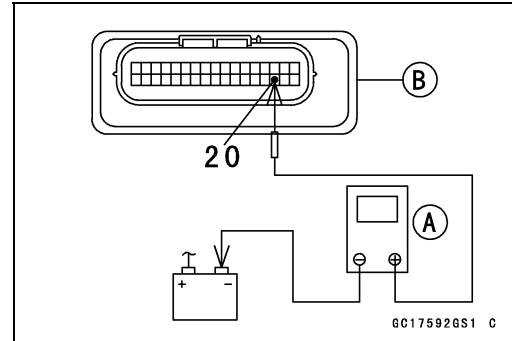

### **⚠ WARNING**

**Fuel is flammable and explosive under certain conditions and can cause severe burns. Be prepared for fuel spillage; any spilled fuel must be completely wiped up immediately. When the fuel hose is disconnected, fuel spills out from the hose and the pipe because of residual pressure. Cover the hose connection with a piece of clean cloth to prevent fuel spillage.**

**Fuel Injector (Service Code 41) (DTC P0201)**

- Check the fuel injector fuel line for leakage as follows.
- Connect a commercially available vacuum/pressure pump [A] to the nipple of the delivery pipe [B] with the fuel hose [C] (both ends with the clamps [D]) as shown.
- Apply soap and water solution to the areas [F] as shown.
- Watching the pressure gauge, squeeze the pump lever [G], and build up the pressure until the pressure reaches the maximum pressure.

**Injector Fuel Line Maximum Pressure**  
**Standard: 300 kPa (3.06 kgf/cm<sup>2</sup>, 43 psi)**

**NOTICE**

**During pressure testing, do not exceed the maximum pressure for which the system is designed.**

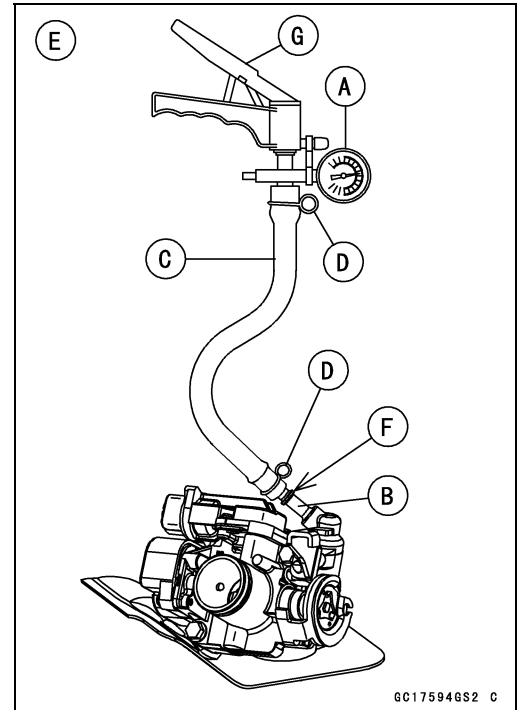

- Watch the gauge for at least 6 seconds.
- ★ If the pressure holds steady, the fuel line is good.
- ★ If the pressure drops at once or if bubbles are found in the area, the fuel line is leaking. Replace the delivery pipe, injector and related parts.
- Repeat the leak test, and check the fuel line for no leakage.
- Install the removed parts (see appropriate chapters).
- Start the engine and check for fuel leakage.

# 3-70 FUEL SYSTEM (DFI)

## Fuel Injector (Service Code 41) (DTC P0201)

### Fuel Injector Circuit

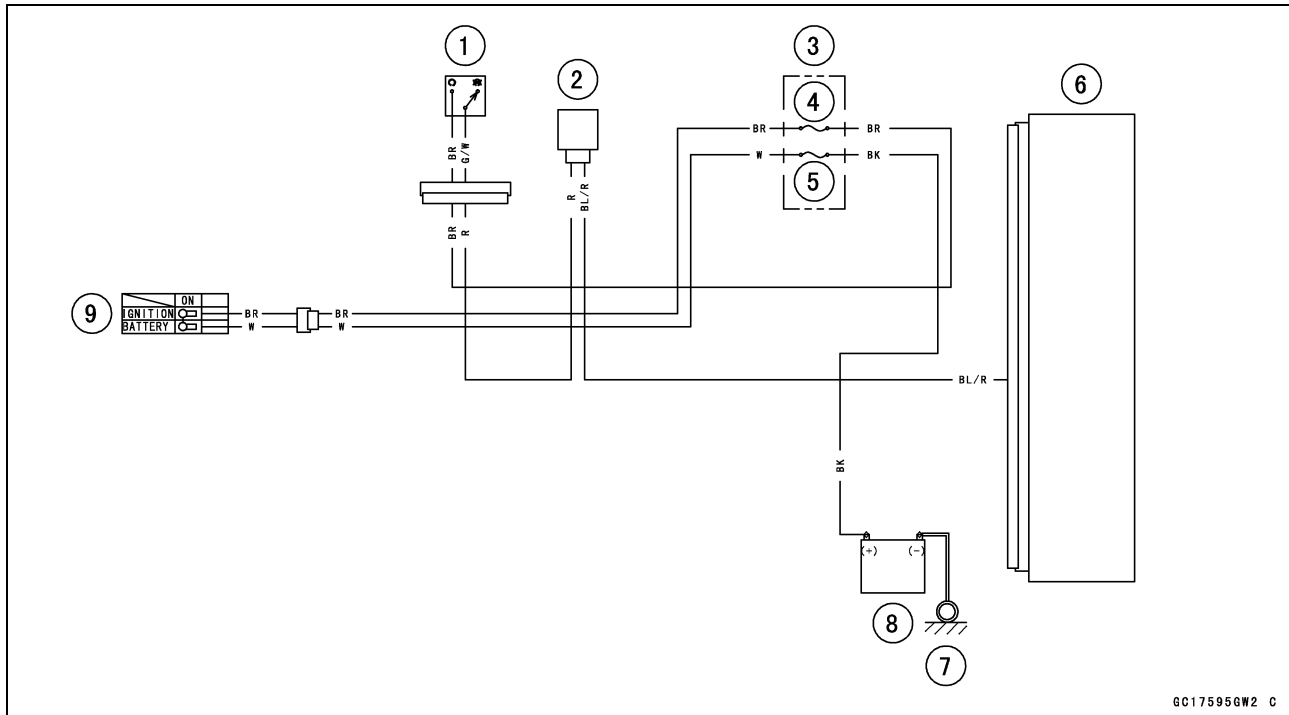

1. Engine Stop Switch
2. Fuel Injector
3. Fuse Box
4. Ignition Fuse 10 A
5. Battery Fuse 20 A
6. ECU
7. Engine Ground
8. Battery 12 V 3 Ah
9. Ignition Switch

## Ignition Coil (Service Code 51) (DTC P0351)

### Ignition Coil Removal/Installation

- Refer to the Ignition Coil Removal/Installation in the Electrical System chapter.

### Ignition Coil Primary Winding Resistance Inspection

- Refer to the Ignition Coil Inspection in the Electrical System chapter.
- ★ If the reading is within the standard, check the input voltage (see Ignition Coil Input Voltage Inspection).

### Ignition Coil Input Voltage Inspection

#### NOTE

○ Be sure the battery is fully charged.

- Turn the ignition switch off.
- Remove:
  - ECU (see ECU Removal)
  - Left Side/Frame Cover (see Side/Frame Cover Removal in the Frame chapter)
- Pull out the ECU connector [A] to the outside of the frame.
- Connect the ECU connector.
- Connect a digital meter [A] to the connector [B] with the needle adapter set.

**Special Tool - Needle Adapter Set: 57001-1457**

#### Ignition Coil Input Voltage

##### Connections to ECU Connector:

**Digital Meter (+) → BK lead (ECU terminal 1)**

**Digital Meter (-) → Frame Ground Terminal**

- Measure the input voltage to the primary winding of the ignition coil with the engine stopped and with the connector joined.
- Turn the engine stop switch to run position.
- Turn the ignition switch on.

#### Input Voltage

**Standard: Battery Voltage**

- Turn the ignition switch off.
- ★ If the input voltage is out of the standard, check the wiring for continuity (see Ignition Coil Circuit).
- ★ If the wiring is good, check the ECU for its ground and power supply (see ECU Power Supply Inspection).
- ★ If the ground and power supply are good, replace the ECU (see ECU Removal/Installation).
- ★ If the input voltage is within the standard, check the ECU for its ground and power supply (see ECU Power Supply Inspection).
- ★ If the ground and power supply are good, replace the ECU (see ECU Removal/Installation).

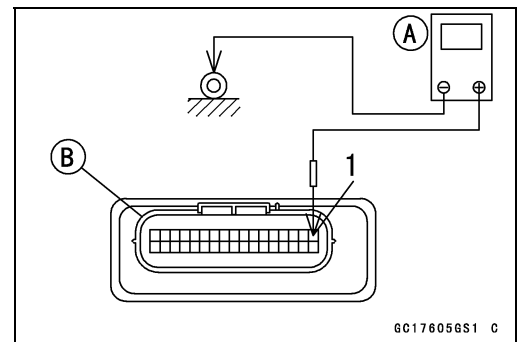

## 3-72 FUEL SYSTEM (DFI)

### Ignition Coil (Service Code 51) (DTC P0351)

#### Ignition Coil Circuit

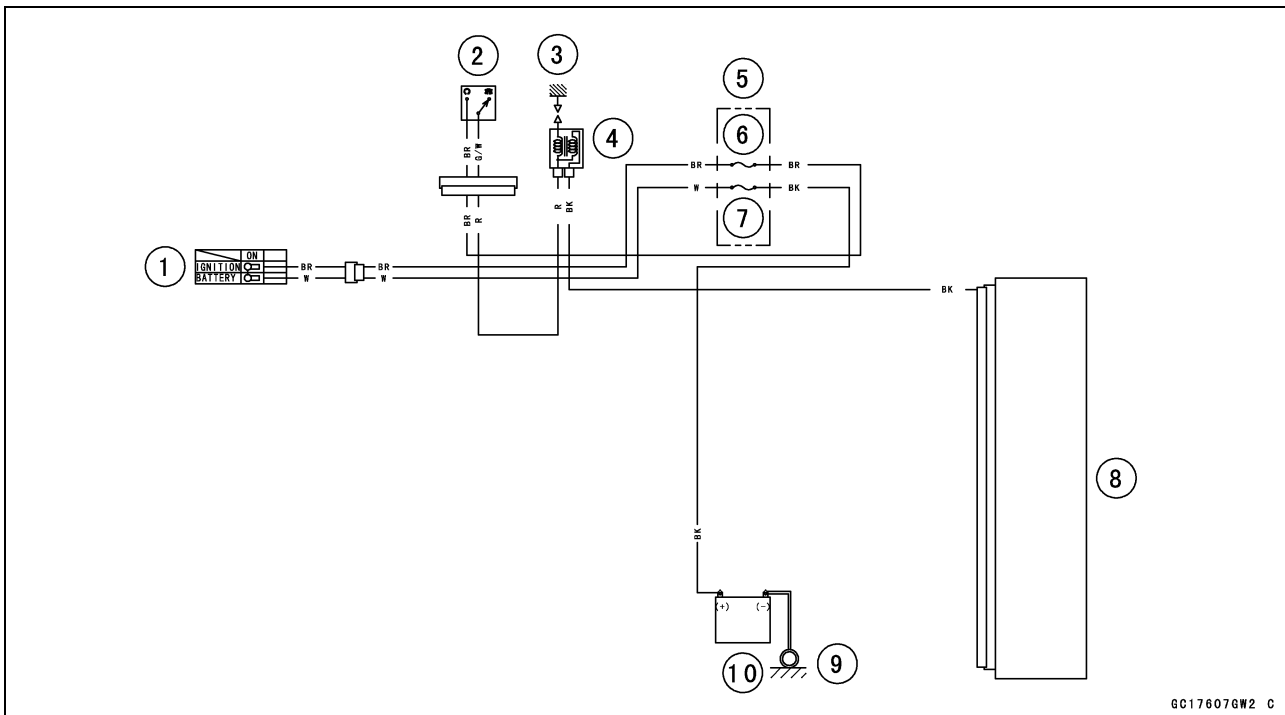

1. Ignition Switch
2. Engine Stop Switch
3. Spark Plug
4. Ignition Coil
5. Fuse Box
6. Ignition Fuse 10 A
7. Battery Fuse 20 A
8. ECU
9. Engine Ground
10. Battery 12 V 3 Ah



**Oxygen Sensor Heater (Service Code 67) (DTC P0030)**

**Oxygen Sensor Heater Removal/Installation**

The oxygen sensor heater is built in the oxygen sensor. So, the heater itself can not be removed. Remove the oxygen sensor (see Oxygen Sensor Removal in the Electrical System chapter).

**Oxygen Sensor Heater Resistance Inspection**

- Turn the ignition switch off.
- Remove:
  - Right Side/Frame Cover (see Side/Frame Cover Removal in the Frame chapter)
- Remove the oxygen sensor lead connector [A] from the bracket.
- Disconnect the oxygen sensor lead connector.
  
- Connect a digital meter [A] to the oxygen sensor lead connector [B].
- Measure the oxygen sensor heater resistance.

**Oxygen Sensor Heater Resistance**

**Connections: W lead [C] ↔ W lead [D]**

**Standard: 13.0 ~ 18.5 Ω @20°C (68°F)**

- ★ If the reading is out of the standard, replace the sensor.
- ★ If the reading is within the standard, check the power source voltage (see Oxygen Sensor Heater Power Source Voltage Inspection).

**Oxygen Sensor Heater Power Source Voltage Inspection**

**NOTE**

○ Be sure the battery is fully charged.

- Turn the ignition switch off.
- Remove:
  - Right Side/Frame Cover (see Side/Frame Cover Removal in the Frame chapter)
- Remove the oxygen sensor lead connector [A] from the bracket.

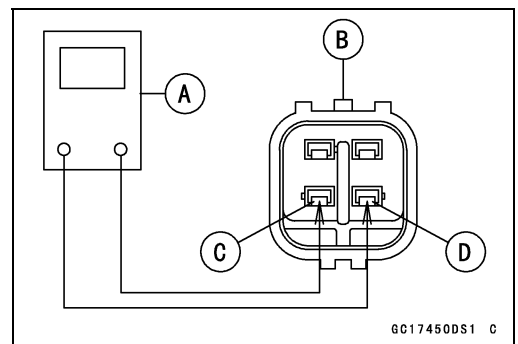

## 3-74 FUEL SYSTEM (DFI)

### Oxygen Sensor Heater (Service Code 67) (DTC P0030)

- Disconnect the oxygen sensor lead connector and connect the measuring adapter [A] between these connectors as shown.

Main Harness [B]  
Oxygen Sensor [C]

**Special Tool - Measuring Adapter: 57001-1700**

- Connect a digital meter [D] to the measuring adapter leads.

#### Oxygen Sensor Power Source Voltage

##### Connections to Adapter:

Digital Meter (+) → Y (main harness BR) lead

Digital Meter (-) → Frame Ground Terminal

- Measure the power source voltage with the engine stopped and with the connector joined.
- Turn the ignition switch on.

#### Power Source Voltage

**Standard: Battery Voltage**

- Turn the ignition switch off.
- ★ If the reading is in specification, but the problem still exists, replace the ECU (see ECU Removal/Installation).
- ★ If the reading is out of the standard, check the following.
  - Ignition Fuse 10 A (see Fuse Inspection in the Electrical System chapter)
  - Power Source Wiring (see Oxygen Sensor Circuit)
- ★ If the fuse and wiring are good, remove the ECU and check the wiring for continuity between main harness connectors.
- Disconnect the ECU and sensor connectors.

#### Wiring Continuity Inspection

ECU Connector [A] ↔

Oxygen Sensor Connector [B]

R/W lead (ECU terminal 3) [C]

- ★ If the wiring is good, check the ECU for its ground and power supply (see ECU Power Supply Inspection).
- ★ If the ground and power source are good, replace the ECU (see ECU Removal/Installation).

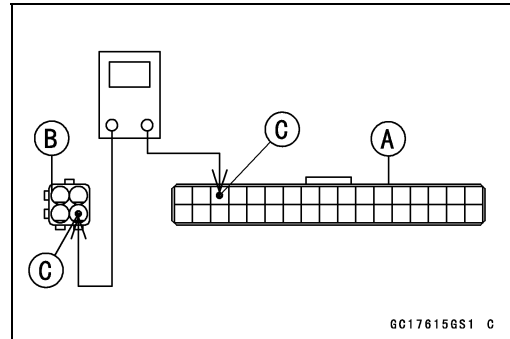
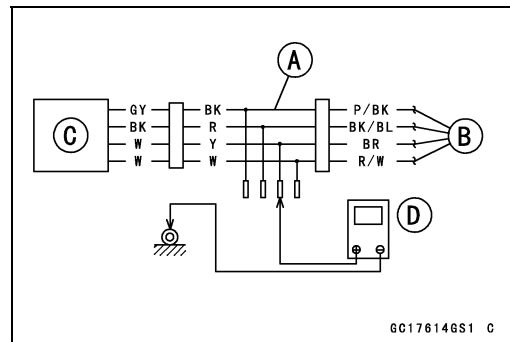
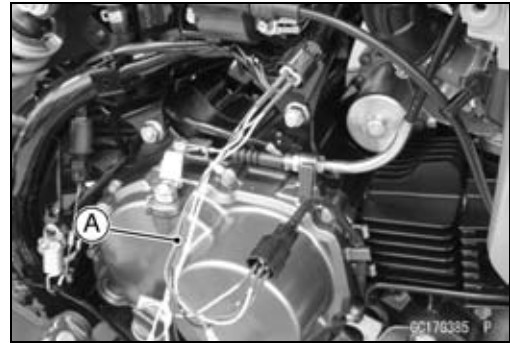

Oxygen Sensor Heater (Service Code 67) (DTC P0030)

Oxygen Sensor Circuit

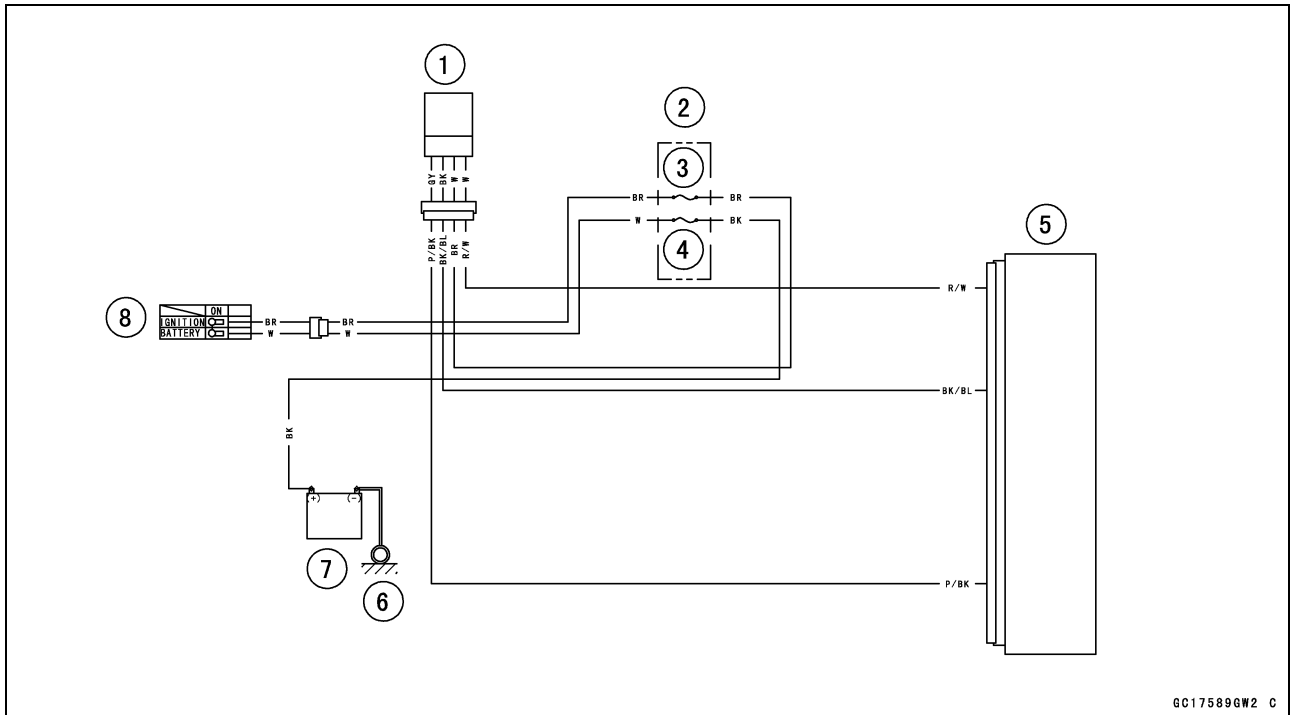

GC17589GW2 C

1. Oxygen Sensor
2. Fuse Box
3. Ignition Fuse 10 A
4. Battery Fuse 20 A
5. ECU
6. Engine Ground
7. Battery 12 V 3 Ah
8. Ignition Switch

## 3-76 FUEL SYSTEM (DFI)

---

### Fuel Supply System (Service Code 94) (DTC P0170)

---

#### *Fuel Supply System Inspection*

##### **NOTE**

○If the motorcycle has any other service code, first inspect the other service code.

- Inspect the General fuel system (throttle body assy, air cleaner, fuel tank etc.).
- ★ If the General fuel system is good, check the ECU for its ground and power supply (see ECU Power Supply Inspection).
- ★ If the ground and power supply are good, replace the ECU (see ECU Removal/Installation).

**Idle Speed Control Valve Actuator (Service Code 1C) (DTC P0508, P0511, P0519)**

**Idle Speed Control Valve Actuator Removal**

<b>NOTICE</b>
<p><b>Never drop the idle speed control valve actuator especially on a hard surface. Such a shock to the actuator can damage it.</b></p>

- Remove:
  - Throttle Body Assy (see Throttle Body Assy Removal)
  - Idle Speed Control Valve Actuator Screws [A]
  - Idle Speed Control Valve Actuator [B]

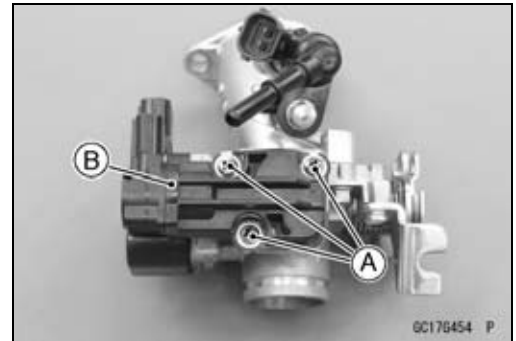

**Idle Speed Control Valve Actuator Installation**

- Replace the O-ring [A] with a new one.
- Fit the holes [B] of the idle speed control valve actuator to the projections [C] of the throttle body assy.

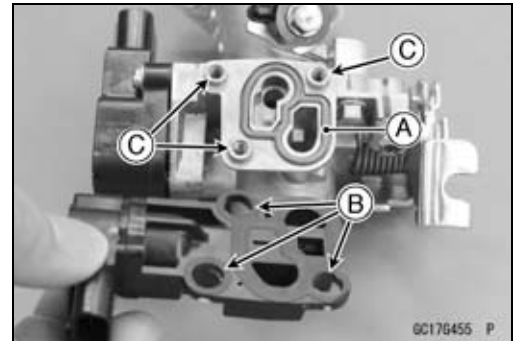

- Tighten:
  - Torque - Idle Speed Control Valve Actuator Screws: 2.1 N·m (0.21 kgf·m, 19 in·lb)**
- Install the removed parts (see appropriate chapters).
- Reset and registration the throttle sensor position data (see Throttle Sensor Position Data Reset and Registration).
- Inspect the idle speed (see Idle Speed Inspection in the Periodic Maintenance chapter).

**Idle Speed Control Valve Actuator Resistance Inspection**

- Turn the ignition switch off.
- Remove the air cleaner housing (see Air Cleaner Housing Removal).
- Disconnect the idle speed control valve actuator connector [A].

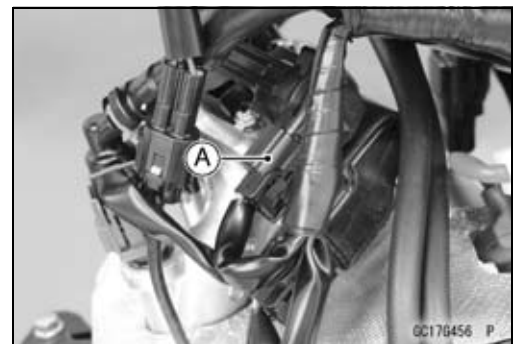

- Connect a digital meter to the idle speed control valve actuator [A].
- Measure the idle speed control valve actuator resistance.

**Idle Speed Control Valve Actuator Resistance**

**Connections:** BK/BL lead [1] ↔ P lead [4]  
 W/BL lead [2] ↔ G/Y lead [3]

**Standard:** About 120 Ω @20°C (68°F)

- ★ If the reading is out of the standard, replace the idle speed control valve actuator.
- ★ If the reading is within the standard, check the input voltage (see Idle Speed Control Valve Actuator Input Voltage Inspection).

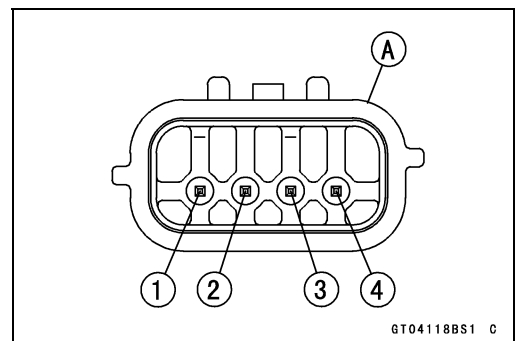

## 3-78 FUEL SYSTEM (DFI)

### Idle Speed Control Valve Actuator (Service Code 1C) (DTC P0508, P0511, P0519)

#### Idle Speed Control Valve Actuator Input Voltage Inspection

##### NOTE

○Be sure the battery is fully charged.

- Turn the ignition switch off.
- Remove the air cleaner housing (see Air Cleaner Housing Removal).
- Disconnect the idle speed control valve actuator connector and connect a measuring adapter [A] between these connectors as shown.

Main Harness [B]

Idle Speed Control Valve Actuator [C]

**Special Tool - Measuring Adapter: 57001-1700**

- Connect the peak voltage adapter [D] and a digital meter [E] to the measuring adapter leads.

**Special Tool - Peak Voltage Adapter: 57001-1415**  
**Type: KEK-54-9-B**

#### Idle Speed Control Valve Actuator Input Voltage Connections to Adapter:

(I) Digital Meter (+) → R (actuator P) lead

Digital Meter (-) → Frame Ground Terminal

(II) Digital Meter (+) → W (actuator G/Y) lead

Digital Meter (-) → Frame Ground Terminal

(III) Digital Meter (+) → Y (actuator W/BL) lead

Digital Meter (-) → Frame Ground Terminal

(IV) Digital Meter (+) → BK (actuator BK/BL) lead

Digital Meter (-) → Frame Ground Terminal

- Measure the actuator input voltage with the engine stopped and with the connector joined.
- Turn the ignition switch on.

#### Input Voltage

**Standard: About DC 7.2 ~ 14.2 V and then 0 V or About DC 7.2 ~ 14.2 V**

- Turn the ignition switch off.
- ★ If the reading is out of the specification, remove the ECU and check the wiring for continuity between main harness connectors.
- Disconnect the ECU and actuator connectors.

#### Wiring Continuity Inspection

**ECU Connector [A] ↔**

**Idle Speed Control Valve Actuator Connector [B]**

**P lead (ECU terminal 17) [C]**

**G/Y lead (ECU terminal 15) [D]**

**W/BL lead (ECU terminal 32) [E]**

**BK/BL lead (ECU terminal 34) [F]**

- ★ If the wiring is good, check the ECU for its ground and power supply (see ECU Power Supply Inspection).
- ★ If the ground and power supply are good, replace the ECU (see ECU Removal/Installation).

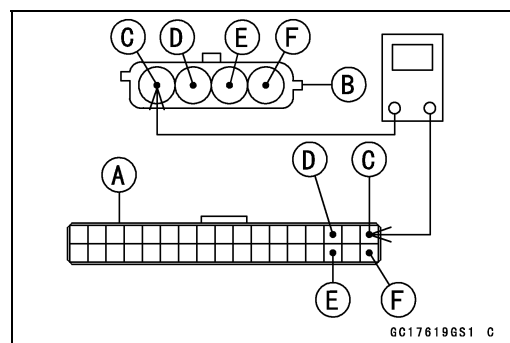
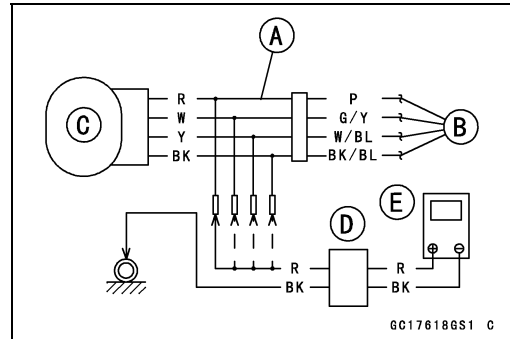

Idle Speed Control Valve Actuator (Service Code 1C) (DTC P0508, P0511, P0519)

Idle Speed Control Valve Actuator Circuit

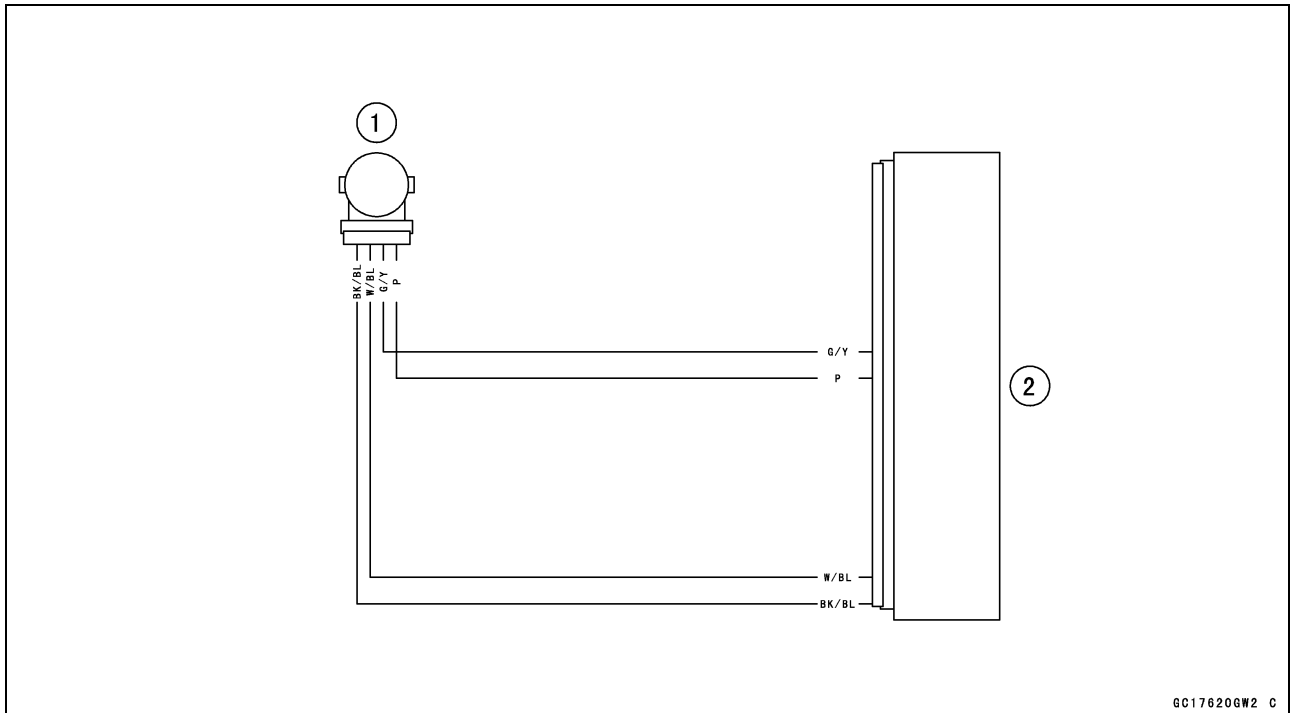

- 1. Idle Speed Control Valve Actuator
- 2. ECU

## 3-80 FUEL SYSTEM (DFI)

### Purge Valve (Service Code 3A) (DTC P0443) (CAL Model)

#### Purge Valve Removal/Installation

- Remove:
  - Right Side/Frame Cover (see Side/Frame Cover Removal in the Frame chapter)
- Slide the clamps [A].
- Disconnect:
  - Purge Valve Lead Connector [B]
  - Hoses [C]
- Remove:
  - Purge Valve Nut [D]
  - Purge Valve [E]
- Installation is the reverse of removal.
- Tighten:
  - Torque - Purge Valve Nut: 8.8 N·m (0.90 kgf·m, 78 in·lb)**
- Run the hoses correctly (see Cable, Wire, and Hose Routing section in the Appendix chapter).

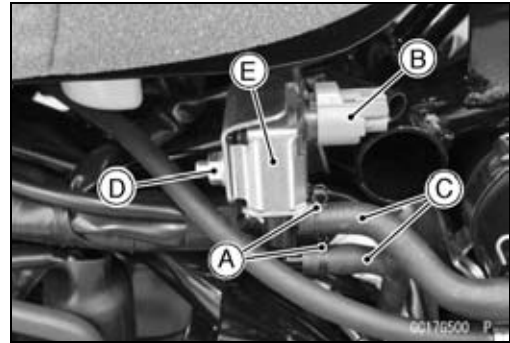

#### Purge Valve Inspection

- Remove the purge valve (see Purge Valve Removal/Installation).
- Connect a digital meter [A] to the purge valve terminals as shown.

##### Purge Valve Resistance

Standard: 30 ~ 34  $\Omega$  @20°C (68°F)

- ★ If the resistance reading is out of the specified value, replace it with a new one.
- Connect the 12 V battery [A] to the purge valve terminals as shown.

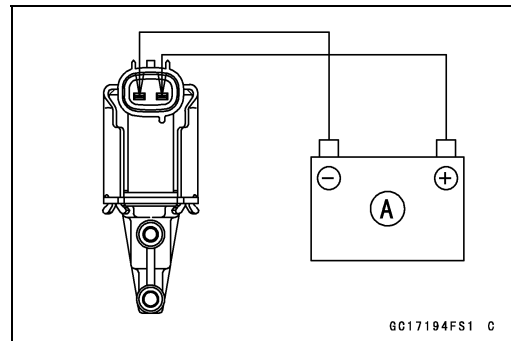
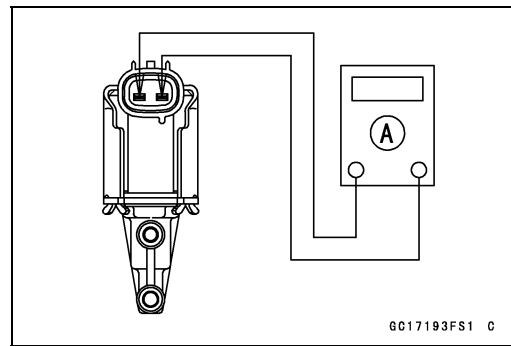

- Blow the air to the intake air duct [A], and make sure that the air flows from the outlet air duct [B].

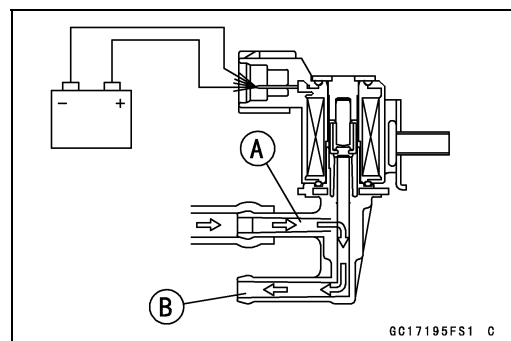



## Purge Valve (Service Code 3A) (DTC P0443) (CAL Model)

- Disconnect the 12 V battery.
- Blow the air to the intake air duct [A] again, and make sure that the air does not flow from the outlet air duct [B].
- ★ If the purge valve dose not operate as described, replace it with a new one.

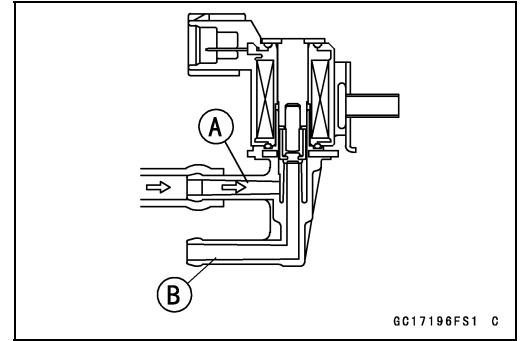

## Purge Valve Circuit

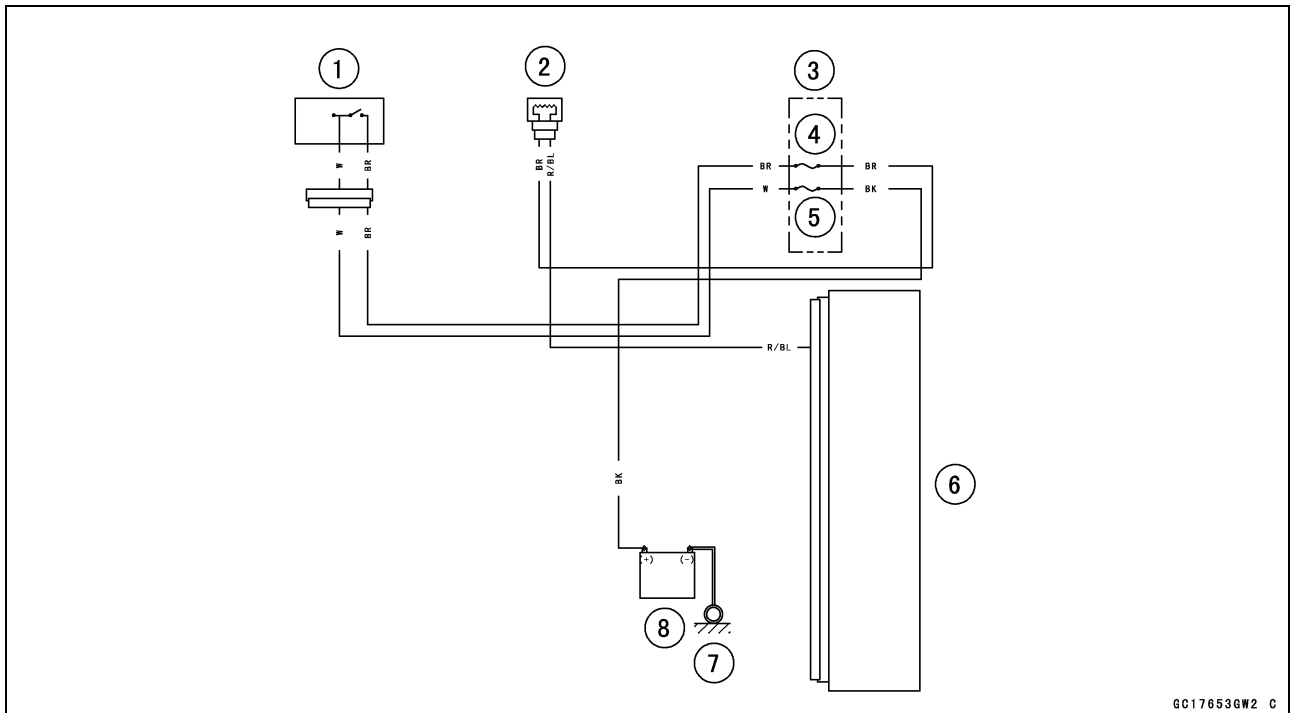

1. Ignition Switch
2. Purge Valve
3. Fuse Box
4. Ignition Fuse 10 A
5. Battery Fuse 20 A
6. ECU
7. Engine Ground
8. Battery 12 V 3 Ah

### 3-82 FUEL SYSTEM (DFI)

#### Yellow Engine Warning Indicator Light (LED)

##### Yellow Engine Warning Indicator Light (LED) Inspection

Yellow Engine Warning Indicator Light (LED) [A]

- In this model, the yellow engine warning indicator light (LED) goes on or blinks by the data sent from the ECU.
- Refer to the Meter Unit Inspection in the Electrical System chapter.



#### Yellow Engine Warning Indicator Light (LED) Circuit for DFI System

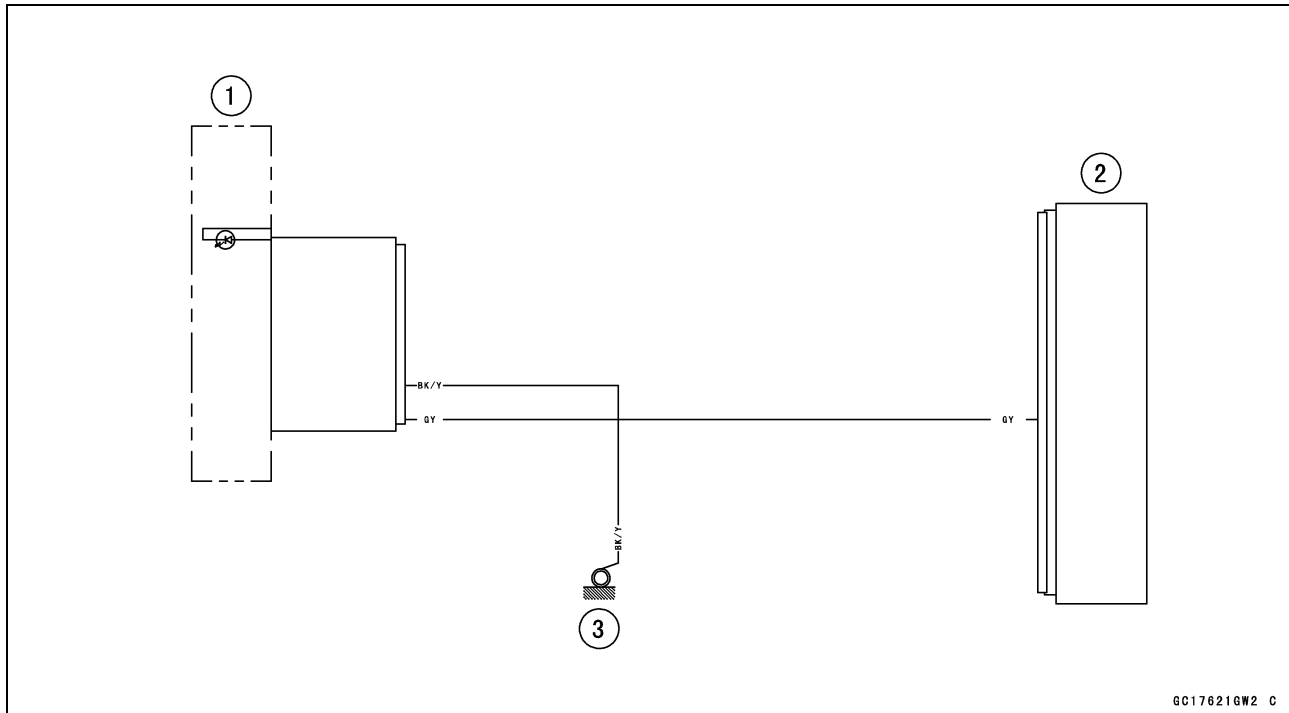

- 1. Meter Unit
- 2. ECU
- 3. Frame Ground

**ECU**

**ECU Identification**

○Most countries have their own regulations, so each ECU has different characteristic. So, do not confuse ECU with each other and use only the ECU for your model. Otherwise, the motorcycle cannot clear the regulation.

**ECU Identification**

Part Number [A]	Specification
21175-1110	BR125H, TH
	BR125H, MY
21175-1144	BR125G, TH
21175-1145	BR125J, CA
	BR125J, US
21175-1146	BR125J, AU
21175-1147	BR125J, CAL
21175-1178	BR125G, PH
21175-1179	BR125H, ID

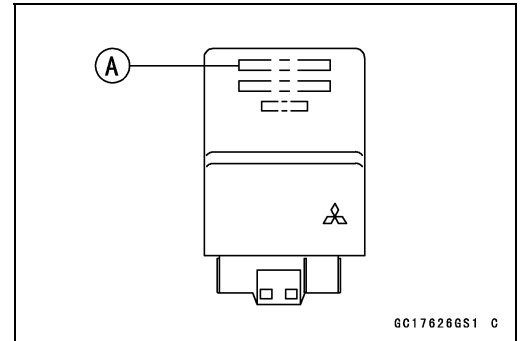

**ECU Removal**

**NOTICE**

**Never drop the ECU especially on a hard surface. Such a shock to the ECU can damage it.**

- Remove the seat (see Seat Removal in the Frame chapter).
- Lift up the ECU [A] with rubber protector [B] to clear the projections [C].
- Disconnect the ECU connector [D].
- Remove the ECU from the rubber protector.

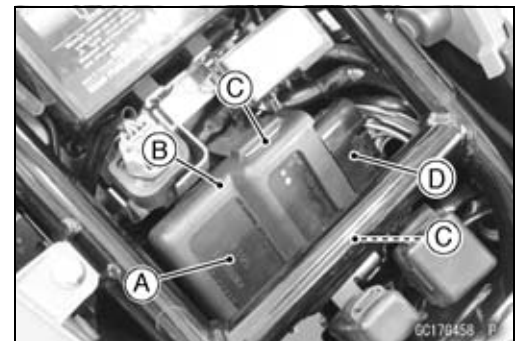

**ECU Installation**

- Install the ECU [A] to the rubber protector [B].
- Connect the ECU connector.
- Insert the slits of the rubber protector to the projections [C] of the bracket.
- Install the seat (see Seat Installation in the Frame chapter).
- ★ If the ECU is replaced, reset and registration the throttle sensor position data.

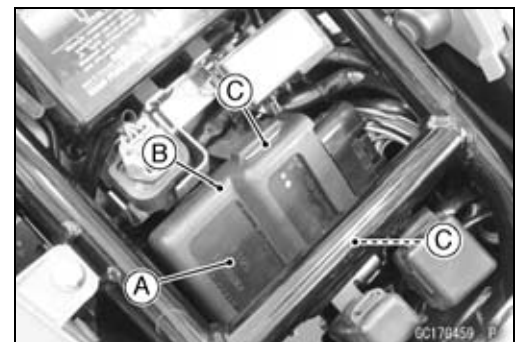

# 3-84 FUEL SYSTEM (DFI)

## ECU

### Throttle Sensor Position Data Reset and Registration

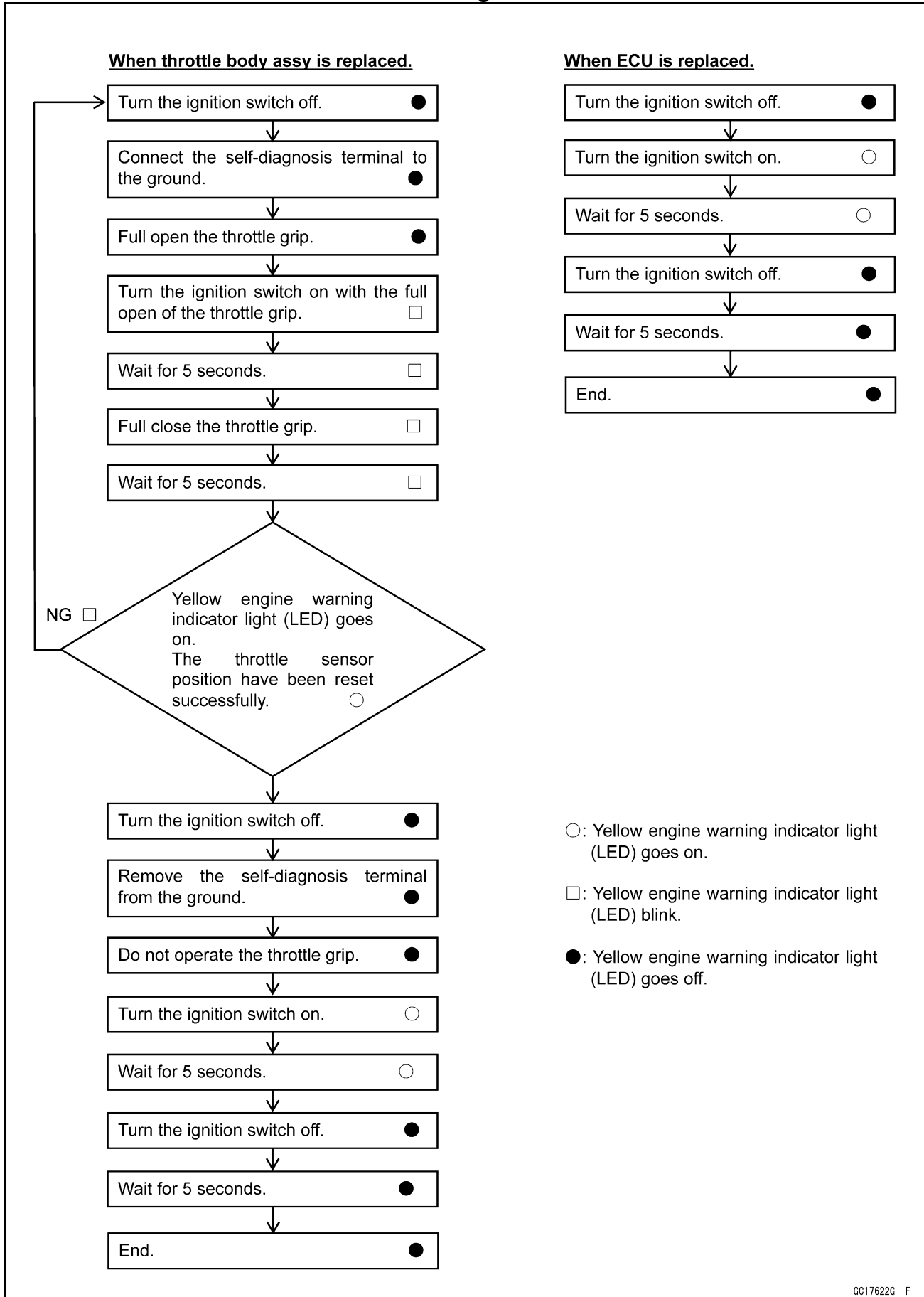

**ECU**

**ECU Power Supply Inspection**

- Visually inspect the ECU connector.
- ★ If the connector is clogged with mud or dust, blow it off with compressed air.
- Remove the ECU (see ECU Removal).
- Visually inspect the terminals [A] of the ECU and main harness connector.
- ★ If the terminals of the main harness connector is damaged, replace the main harness.
- ★ If the terminals of the ECU connector is damaged, replace the ECU.

- Turn the ignition switch off.
- Disconnect the ECU connector [A].
- Set a tester [B] and check the following wiring for continuity.

**ECU Grounding Inspection**

**Connections:**

- (I) BK/Y leads (ECU terminal 7, 16 or 18) ↔ Battery (-) terminal
- (II) Engine Ground ↔ Battery (-) terminal

**Criteria:**

**Both: About 0 Ω**

- ★ If no continuity, check the connector, the engine ground lead, or main harness, and repair or replace them if necessary.
- ★ If the wiring is good, check the power source voltage of the ECU.

**NOTE**

○ Be sure the battery is fully charged.

- Remove:
  - ECU (see ECU Removal)
  - Left Side/Frame Cover (see Side/Frame Cover Removal in the Frame chapter)
- Pull out the ECU connector [A] to the outside of the frame.
- Connect the ECU connector.

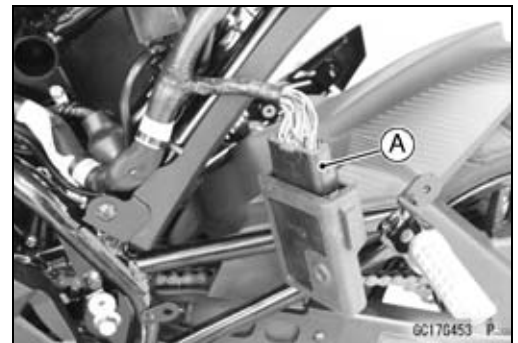
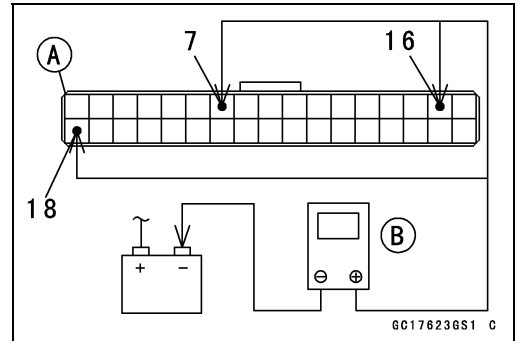
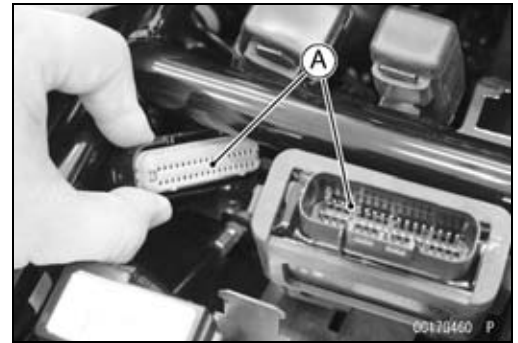

# 3-86 FUEL SYSTEM (DFI)

## ECU

- Connect a digital meter [A] to the ECU connector [B] with the needle adapter set.

**Special Tool - Needle Adapter Set: 57001-1457**

### ECU Power Supply Inspection

**Connections:**

- (I) Digital Meter (+) → Terminal 11 (BR)
- Digital Meter (-) → Battery (-) terminal
- (II) Digital Meter (+) → Terminal 9 (W)
- Digital Meter (-) → Battery (-) terminal

**Ignition Switch off:**

- Terminal 11 (BR): 0 V
- Terminal 9 (W): Battery Voltage

**Ignition Switch on:**

- Both: Battery Voltage

- ★ If the reading is out of the specification, check the following.

Battery Fuse 20 A (see Fuse Inspection in the Electrical System chapter)

Ignition Fuse 10 A (see Fuse Inspection in the Electrical System chapter)

Power Source Wiring (see ECU Power Source Circuit)

- ★ If the fuse and wiring are good, replace the ECU (see ECU Removal/Installation).

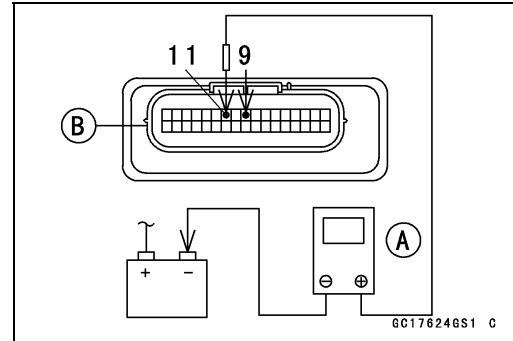

### ECU Power Source Circuit

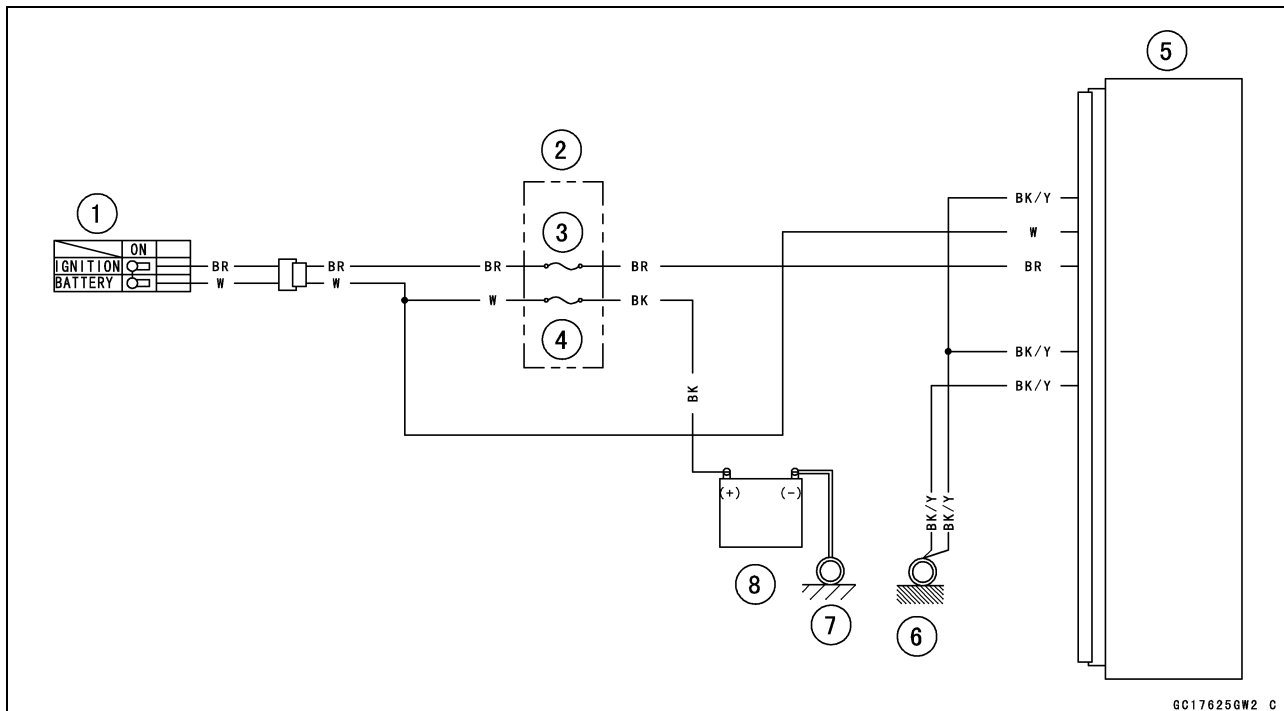

1. Ignition Switch
2. Fuse Box
3. Ignition Fuse 10 A
4. Battery Fuse 20 A
5. ECU
6. Frame Ground
7. Engine Ground
8. Battery 12 V 3 Ah

**Fuel Line**

**Fuel Pressure Inspection**

**NOTE**

○Be sure the battery is fully charged.

- Remove:
  - Middle Fairings (see Middle Fairing Removal in the Frame chapter)
  - Air Cleaner Housing (see Air Cleaning Housing Removal)
  - Fuel Hose (see Fuel Hose Replacement in the Periodic Maintenance chapter)
- Be sure to place a piece of cloth around the fuel outlet pipe of the fuel pump and the delivery pipe.

<p><b>⚠ WARNING</b></p>
<p><b>Fuel is flammable and explosive under certain conditions and can cause severe burns. Be prepared for fuel spillage; any spilled fuel must be completely wiped up immediately. When the fuel hose is disconnected, fuel spills out from the hose and the pipe because of residual pressure. Cover the hose connection with a piece of clean cloth to prevent fuel spillage.</b></p>

- Install the fuel hose (Special Tool: 57001-1607) [A] until the base of the fuel outlet pipe.
- Install the clamp [B] to the back of the raised rib [C].

**Special Tool - Fuel Hose: 57001-1607**

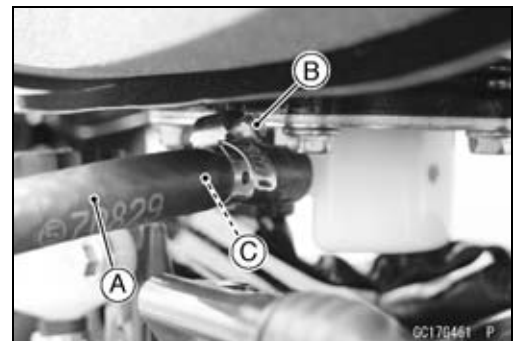

- Install the fuel pressure gauge adapter [A] and fuel hoses (Special Tool: 57001-1607) [B] between the fuel outlet pipe and delivery pipe.
- Secure the fuel hoses with the clamps.
- Connect the pressure gauge [C] to the fuel pressure gauge adapter.

**Special Tools - Oil Pressure Gauge, 5 kgf/cm<sup>2</sup>: 57001-125**  
**Fuel Pressure Gauge Adapter: 57001-1593**  
**Fuel Hose: 57001-1607**

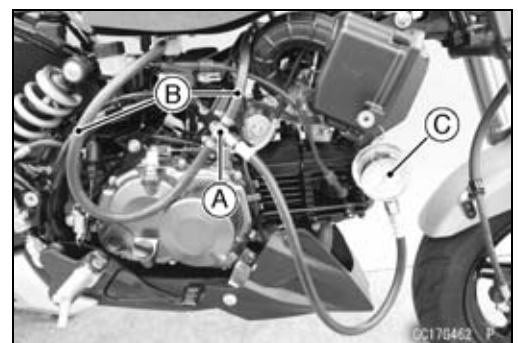

<p><b>⚠ WARNING</b></p>
<p><b>Fuel is extremely flammable and can be explosive under certain conditions resulting in serious injury or death. Do not try to start the engine with the fuel hoses disconnected.</b></p>

- Temporarily install the air cleaner housing (see Air Cleaner Housing Installation).

## 3-88 FUEL SYSTEM (DFI)

### Fuel Line

---

- Turn the engine stop switch run position.
- Turn the ignition switch on.
- The fuel pump should operate for 3 seconds, and then should stop.

#### NOTE

○ After turning on the engine stop switch and ignition switch, inspect the fuel leakage from the connected portion of the special tools.

<b>NOTICE</b>
<b>Do not drive the fuel pump 3 seconds or more without the fuel in the fuel tank. If the fuel pump is driven without the fuel, it may be damaged.</b>

- Start the engine, and let it idle.
- Measure the fuel pressure with the engine idling.

#### Fuel Pressure (with Engine Idling)

Standard: 294 kPa (3.0 kgf/cm<sup>2</sup>, 43 psi)

#### NOTE

○ The gauge needle will fluctuate. Read the pressure at the average of the maximum and minimum indications.

- Turn the ignition switch off.
- ★ If the fuel pressure is much higher than specified, replace the fuel pump because the fuel pressure regulator in the fuel pump have been clogged or stuck.
- ★ If the fuel pressure is much lower than specified, check the following.
  - Fuel Line Leakage (see Fuel Injector Fuel Line Inspection)
  - Amount of Fuel Flow (see Fuel Flow Rate Inspection)
- After above checks, measure the fuel pressure again.
- Remove the pressure gauge, hoses and adapter.
- Install the removed parts (see appropriate chapters).
- Start the engine and check for fuel leakage.

### Fuel Flow Rate Inspection

 <b>WARNING</b>
<b>Gasoline is extremely flammable and can be explosive under certain conditions, creating the potential for serious burns. Make sure the area is well ventilated and free from any source of flame or sparks; this includes any appliance with a pilot light. Do not smoke. Turn the ignition switch off. Be prepared for fuel spillage; any spilled fuel must be completely wiped up immediately.</b>

#### NOTE

○ Be sure the battery is fully charged.



## Fuel Line

- Turn the ignition switch off.
- Wait until the engine cools down.
- Prepare a fuel hose (Special Tool: 57001-1607) and a measuring cylinder.

**Special Tool - Fuel Hose: 57001-1607**

- Remove:
  - Side Frame/Covers (see Side Frame/Cover Removal in the Frame chapter)
- Open the fuel tank cap [A] to lower the pressure in the tank.
- Remove the fuel hose from the fuel pump (see Fuel Tank Removal).
- Be sure to place a piece of cloth around the fuel outlet pipe of the fuel pump.

### **⚠ WARNING**

**Fuel is flammable and explosive under certain conditions and can cause severe burns. Be prepared for fuel spillage; any spilled fuel must be completely wiped up immediately. When the fuel hose is disconnected, fuel spills out from the hose and the pipe because of residual pressure. Cover the hose connection with a piece of clean cloth to prevent fuel spillage.**

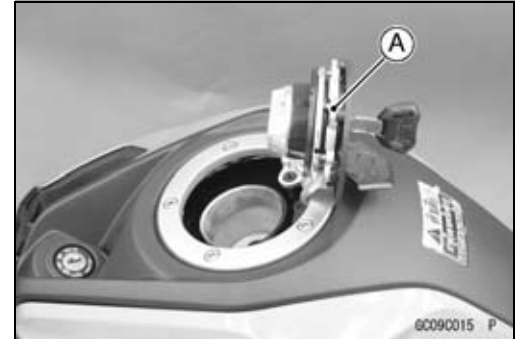

- Install the fuel hose (Special Tool: 57001-1607) [A] until the base of the fuel outlet pipe.
- Install the clamp [B] to the back of the raised rib [C].

**Special Tool - Fuel Hose: 57001-1607**

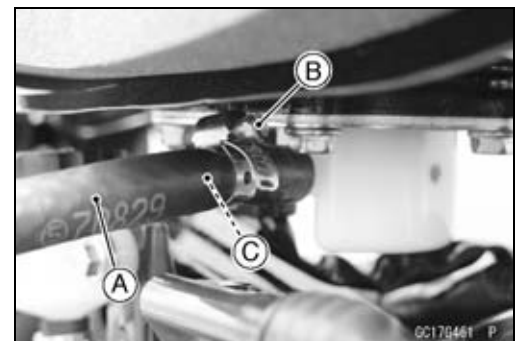

- Insert the fuel hose [A] into the measuring cylinder [B].

### **⚠ WARNING**

**Wipe off spilled out fuel immediately. Be sure to hold the measuring cylinder vertical.**

- Close the fuel tank cap.
- Turn the engine stop switch to run position.
- Turn the ignition switch on.
- The fuel pump should operate for 3 seconds, and then should stop.

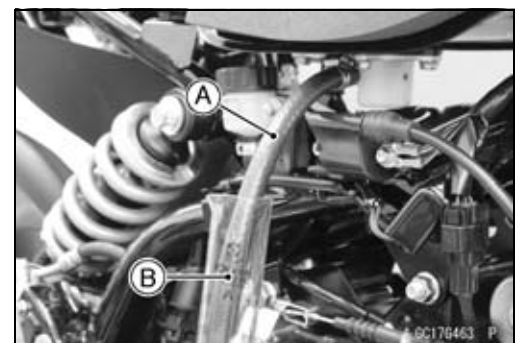

## 3-90 FUEL SYSTEM (DFI)

---

### Fuel Line

---

<b><i>NOTICE</i></b>
----------------------

<p><b>Do not drive the fuel pump 3 seconds or more without the fuel in the fuel tank. If the fuel pump is driven without the fuel, it may be damaged.</b></p>
---

- Measure the discharge for 3 seconds.
- Repeat this operation several times.

#### **Amount of Fuel Flow**

**Standard: 11 mL (0.37 US oz.) or more for 3 seconds**

- Turn the ignition switch off.
- ★ If the fuel flow is much less than the specified, replace the fuel pump (see Fuel Pump Removal/Installation).
- Install the fuel tank (see Fuel Tank Installation).
- Start the engine and check for fuel leakage.

## Fuel Pump

### Fuel Pump Removal

#### **⚠ WARNING**

Gasoline is extremely flammable and can be explosive under certain conditions, creating the potential for serious burns. Make sure the area is well ventilated and free from any source of flame or sparks; this includes any appliance with a pilot light. Do not smoke. Turn the ignition switch off. Disconnect the battery (-) terminal. To avoid fuel spills, draw it from the tank when the engine is cold. Be prepared for fuel spillage; any spilled fuel must be completely wiped up immediately.

#### **NOTICE**

Never drop the fuel pump especially on a hard surface. Such a shock to the pump can damage it.

- Draw the fuel out from the fuel tank with a commercially available pump.
- Remove the fuel tank (see Fuel Tank Removal).
- Be careful of fuel spillage from the fuel tank since fuel still remains in the fuel tank and fuel pump. Plug the fuel pipe of the fuel tank.
- Turn the fuel tank upside down.
- Remove:
  - Fuel Pump Bolts [A]
  - Fuel Pump Plate [B]
  - Fuel Pump [C]

- Discard the fuel pump gasket [A].

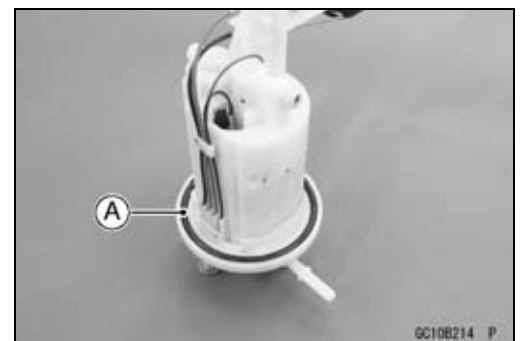
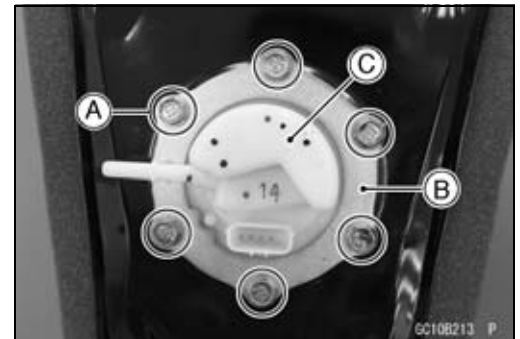

## 3-92 FUEL SYSTEM (DFI)

### Fuel Pump

#### Fuel Pump Installation

- Remove dirt or dust from the fuel pump [A] by lightly applying compressed air.
- Replace the fuel pump gasket with a new one.

#### NOTE

○ Be careful not to bend the fuel level sensor arm.

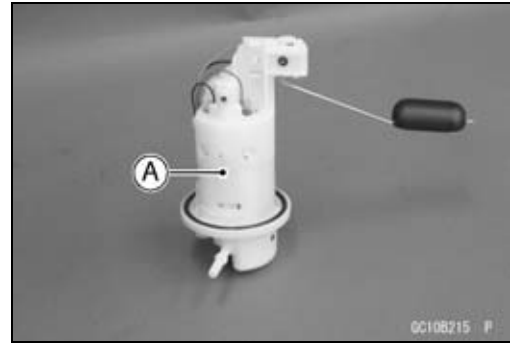

- Install the fuel pump [A] and fuel pump plate [B] as shown.
- Align the outlet pipe [C] and projection [D] of the fuel pump plate with the projection [E] of fuel tank.

Front [F]

- Apply a non-permanent locking agent to the threads of the fuel pump bolts.
- Tighten the fuel pump bolts to a snug fit.
- Tighten the fuel pump bolts alternating diagonally.

**Torque - Fuel Pump Bolts: 9.8 N·m (1.0 kgf·m, 87 in·lb)**

- Tighten the fuel pump bolts again to check the tightness.

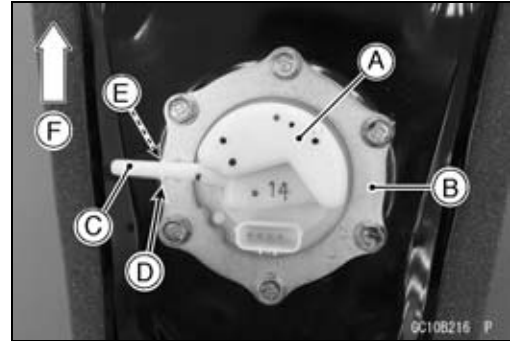

#### Fuel Pump Operation Inspection

#### NOTE

○ Be sure the battery is fully charged.

- Turn the engine stop switch to run position.
- Turn the ignition switch on and make sure that the fuel pump operates (make light sounds) for 3 seconds, and then stops.
- Turn the ignition switch off.
- ★ If the pump does not operate as described above, check the operating voltage (see Fuel Pump Operating Voltage Inspection).

## Fuel Pump

### Fuel Pump Operating Voltage Inspection

#### NOTE

○Be sure the battery is fully charged.

- Turn the ignition switch off.
- Remove the fuel tank bolts (see Fuel Tank Removal).
- Disconnect the fuel pump connector and connect the measuring adapter [A] between these connectors as shown.

Main Harness [B]

Fuel Pump [C]

#### Special Tool - Measuring Adapter: 57001-1700

- Connect a digital meter [D] to the measuring adapter leads.

#### Fuel Pump Operating Voltage

##### Connections to Adapter:

Digital Meter (+) → R (pump P) lead

Digital Meter (-) → BK (pump BK/Y) lead

- Measure the operating voltage with the engine stopped and with the connector joined.
- Turn the engine stop switch to run position.
- Turn the ignition switch on.

#### Operating Voltage

Standard: Battery Voltage for 3 seconds, and then 0 V

- Turn the ignition switch off.
- ★ If the reading stays on battery voltage and never shows 0 V, check the fuel pump relay (see Relay Circuit Inspection in the Electrical System chapter).
- ★ If the fuel pump relay is normal, check the ECU for its ground and power supply (see ECU Power Supply Inspection).
- ★ If the ground and power supply are good, replace the ECU (see ECU Removal/Installation).
- ★ If there is no battery voltage, check the fuel pump relay (see Relay Circuit Inspection in the Electrical System chapter).
- ★ If the fuel pump relay is normal, check the wiring for continuity (see Fuel Pump Circuit).
- ★ If the wiring is good, check the ECU for its ground and power supply (see ECU Power Supply Inspection).
- ★ If the ground and power supply are good, replace the ECU (see ECU Removal/Installation).
- ★ If the reading is in specification, but the pump does not operate, replace the fuel pump (see Fuel Pump Removal/Installation).

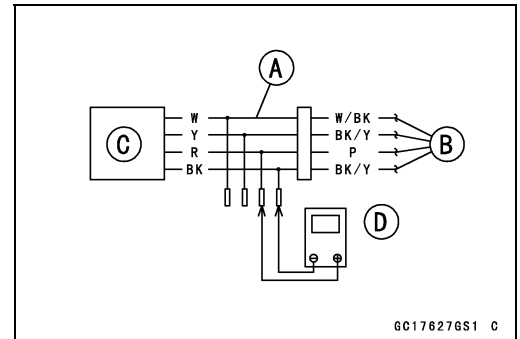

# 3-94 FUEL SYSTEM (DFI)

## Fuel Pump

### Pressure Regulator Removal

○The pressure regulator [A] is built into the fuel pump and can not be removed.

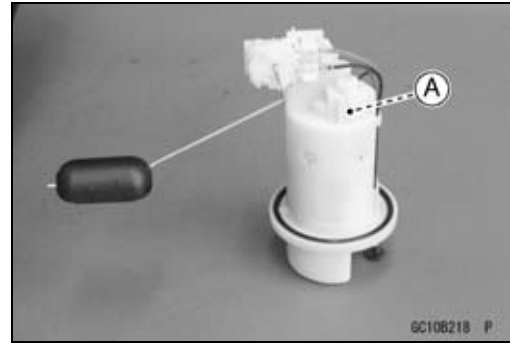

### Fuel Filter Cleaning

○The fuel filter [A] is built into the fuel pump and can not be cleaned or checked.

★If the fuel filter is suspected of clogging or being damaged, replace it with the fuel pump as a set.

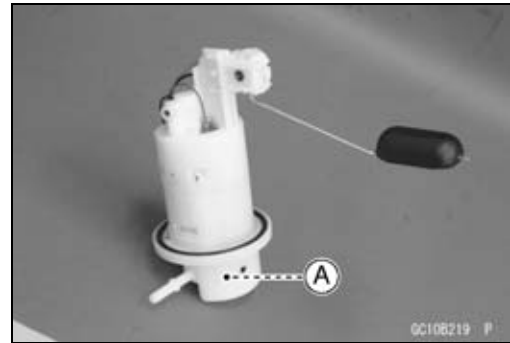

## Fuel Pump Circuit

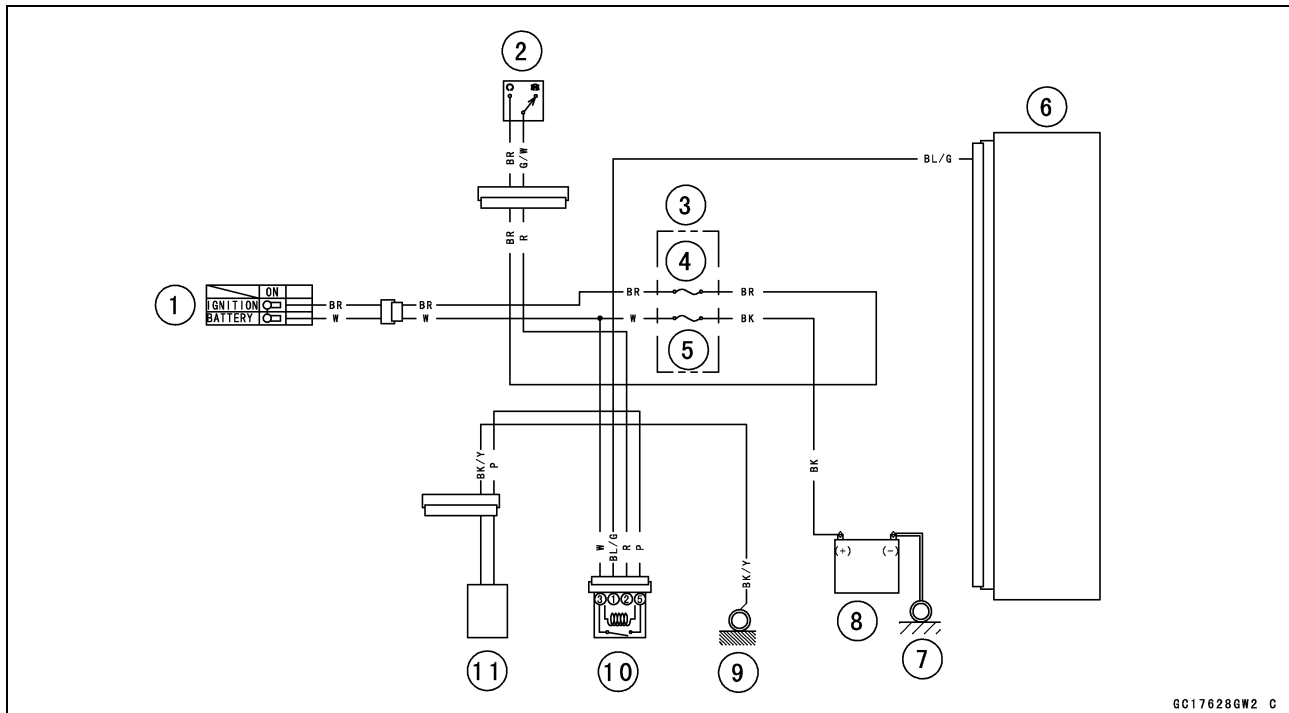

- 1. Ignition Switch
- 2. Engine Stop Switch
- 3. Fuse Box
- 4. Ignition Fuse 10 A
- 5. Battery Fuse 20 A
- 6. ECU
- 7. Engine Ground
- 8. Battery 12 V 3 Ah
- 9. Frame Ground
- 10. Fuel Pump Relay
- 11. Fuel Pump

---

**Throttle Grip and Cable**

---

***Free Play Inspection***

- Refer to the Throttle Control System Inspection in the Periodic Maintenance chapter.

***Free Play Adjustment***

- Refer to the Throttle Control System Inspection in the Periodic Maintenance chapter.

***Cable Installation***

- Install the throttle cable in accordance with the Cable, Wire, and Hose Routing section in the Appendix chapter.
- Install the lower end of the throttle cable in the throttle pulley on the throttle body assy after installing the upper end of the throttle cable in the grip (see Throttle Body Assy Installation).
- After installation, adjust the cable properly (see Throttle Control System Inspection in the Periodic Maintenance chapter).

 <b>WARNING</b>
--

<p><b>Operation with incorrectly routed or improperly adjusted cable could result in an unsafe riding condition. Be sure the cable is routed correctly and properly adjusted.</b></p>
---

***Cable Lubrication***

- Refer to the Chassis Parts Lubrication in the Periodic Maintenance chapter.

## 3-96 FUEL SYSTEM (DFI)

### Throttle Body Assy

#### Idle Speed Inspection/Adjustment

- Refer to the Idle Speed Inspection/Adjustment in the Periodic Maintenance chapter.

#### Throttle Body Assy Removal

#### **⚠ WARNING**

Gasoline is extremely flammable and can be explosive under certain conditions, creating the potential for serious burns. Make sure the area is well ventilated and free from any source of flame or sparks; this includes any appliance with a pilot light. Do not smoke. Turn the ignition switch off. Be prepared for fuel spillage; any spilled fuel must be completely wiped up immediately.

#### **NOTICE**

Never drop the throttle body assy especially on a hard surface. Such a shock to the throttle body assy can damage it.

- Remove:
  - Air Cleaner Housing (see Air Cleaner Housing Removal)
  - Fuel Hose (see Fuel Hose Replacement in the Periodic Maintenance chapter)
- Bend the clamp [A] straighten.
  
- Remove:
  - Starter Motor Mounting Screw [A] and Clamp
  
- Disconnect:
  - Fuel Injector Connector [A]
  - Idle Speed Control Valve Actuator Connector [B]
  - Throttle Body Assy Sensors Connector [C]
  - Engine Temperature Sensor Lead Connector [D]

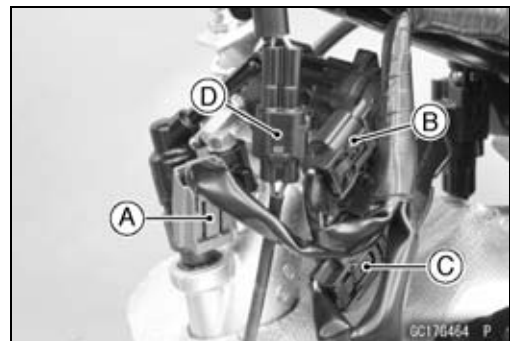



## Throttle Body Assy

- Loosen the throttle cable locknut [A].
- Remove:  
Throttle Cable Lower End [B]

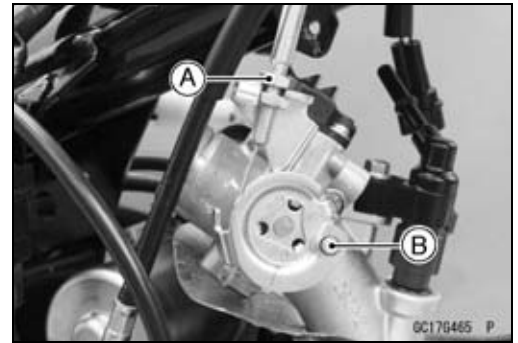

- Slide the clamp [A] (CAL model).
- Disconnect the hose [B] (CAL model).

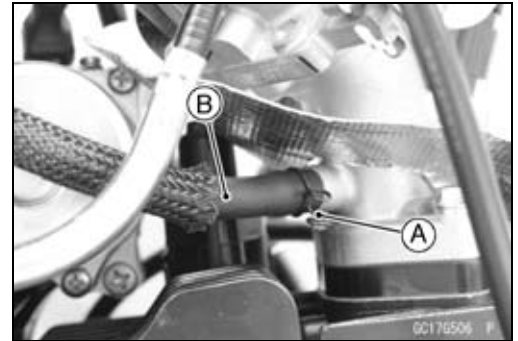

- Remove:  
Intake Pipe Bolts [A] and Washers  
Throttle Body Assy [B]  
Gaskets  
Insulator

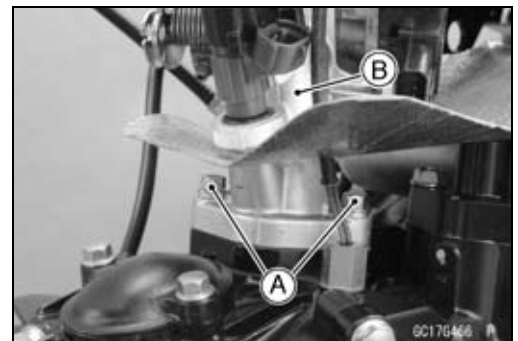

### Other than CAL Model

- Remove the heat insulation guard [A] from the intake pipe [B].

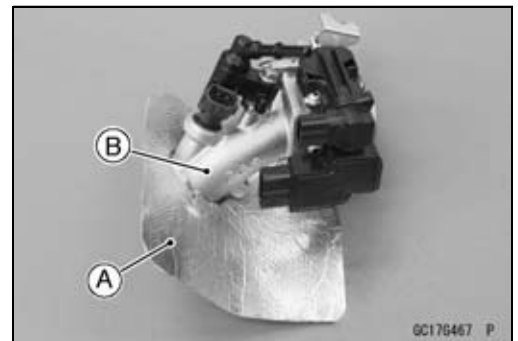

- Remove:  
Throttle Body Assy Mounting Bolts [A]  
Throttle Body Assy [B]  
Intake Pipe [C]

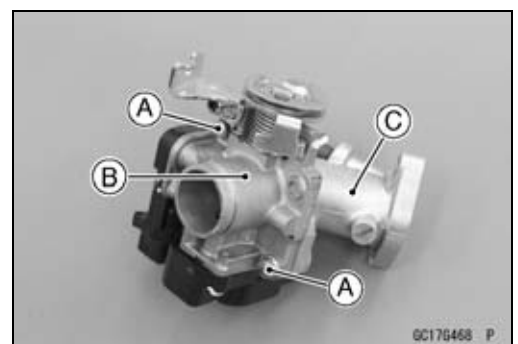

## 3-98 FUEL SYSTEM (DFI)

### Throttle Body Assy

#### CAL Model

- Remove:
  - Throttle Body Assy Mounting Bolts [A]
  - Throttle Body Assy [B]
  - Intake Pipe [C]

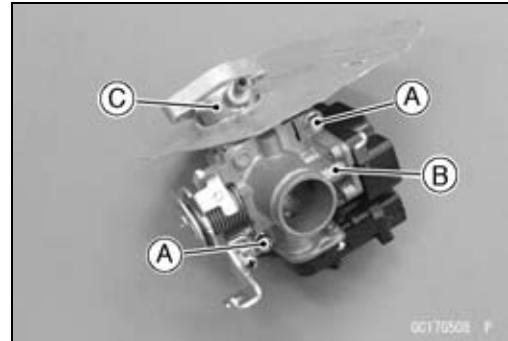

- When removing the heat insulation guard [A], remove the fuel injector (see Fuel Injector Removal).
- Remove the heat insulation guard from the intake pipe [B].

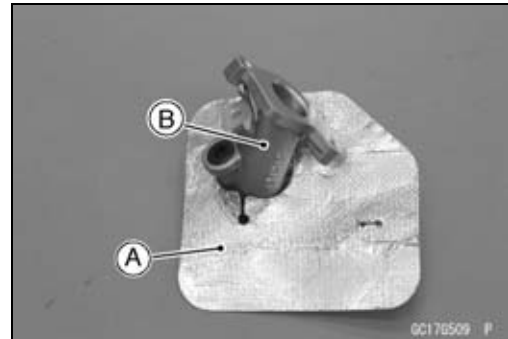

#### Throttle Body Assy Installation

- Install the heat insulation guard to the intake pipe if removed (CAL model).
- Replace the O-ring [A] with a new one.
- Install:
  - Intake Pipe
  - Throttle Body Assy
- Tighten:
  - Torque - Throttle Body Assy Mounting Bolts: 8.8 N·m (0.90 kgf·m, 78 in·lb)**

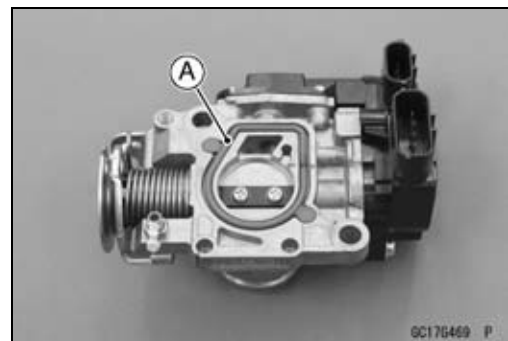

- Replace the gaskets with new ones.
- Install the heat insulation guard to the intake pipe (other than CAL model).
- Install the gaskets [A] [B] and insulator [C] so that the projection [D] faces to the forward [E] as shown.
- Be careful in the direction of the gaskets so as not to block the holes in the insulator.
- Install the throttle body assy [F].
- Tighten the intake pipe bolts [G] with washers.

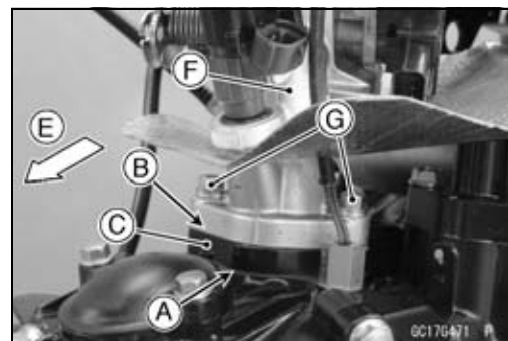

- **Torque - Intake Pipe Bolts: 12 N·m (1.2 kgf·m, 106 in·lb)**
- Run the leads and hose correctly (see Cable, Wire, and Hose Routing section in the Appendix chapter).

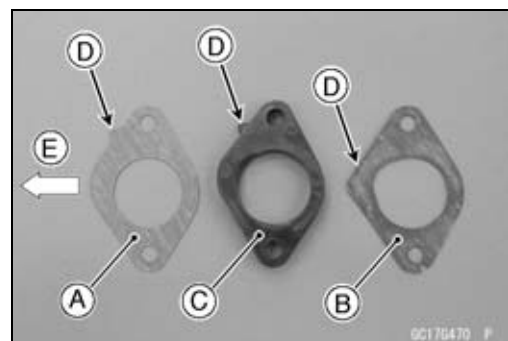

## Throttle Body Assy

- Insert the clamp [A] to the slit [B] of the guard.
- Tighten the starter motor mounting screw [C] as shown.  
About 20° [D]  
Starter Motor [E]

**Torque - Starter Motor Mounting Screw: 5.2 N·m (0.53 kgf·m, 46 in·lb)**

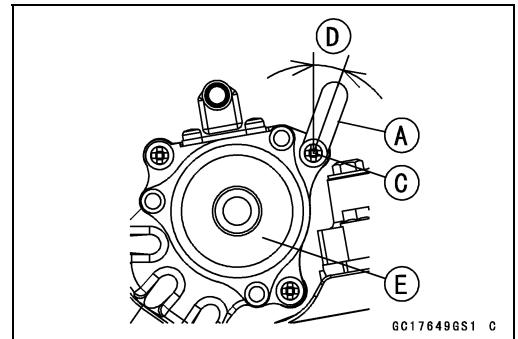
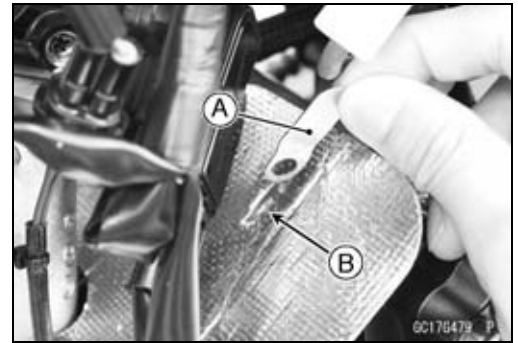

- Bend the clamp [A] as shown.  
About 22 mm (0.87 in.) [B]

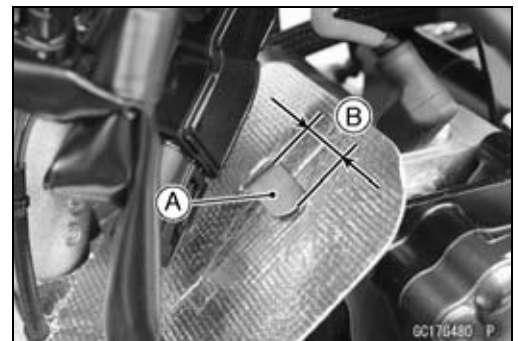

- Apply a thin coat of grease to the throttle cable lower end.
- Fit the throttle cable end [A] into the throttle pulley.
- Install the throttle cable to throttle body Assy.
- Tighten the throttle cable locknut [B].

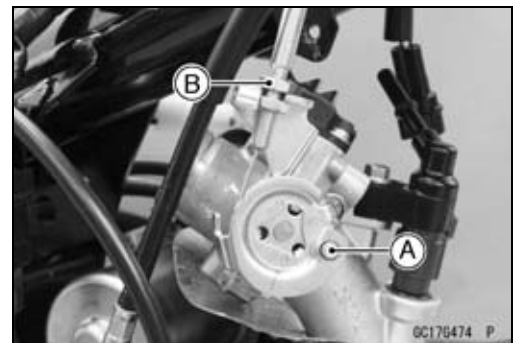

- Turn the throttle grip and make sure that the throttle pulley moves smoothly and return by spring force.
- Run the leads and hoses correctly (see Cable, Wire, and Hose Routing section in the Appendix chapter).
- Install the removed parts (see appropriate chapters).
- Adjust:
  - Throttle Grip Free Play (see Throttle Control System Inspection in the Periodic Maintenance chapter)
  - Throttle Sensor Position Data (see Throttle Sensor Position Data Reset and Registration)
  - Idle Speed (see Idle Speed Adjustment in the Periodic Maintenance chapter)

## 3-100 FUEL SYSTEM (DFI)

---

### Intake Pipe

---

#### ***Intake Pipe Removal***

- Refer to the Throttle Body Assy Removal.
- ★ If necessary, remove the fuel injector (see Fuel Injector Removal).

#### ***Intake Pipe Installation***

- Refer to the Throttle Body Assy Installation.

## Air Cleaner

### **Air Cleaner Element Removal/Installation**

- Refer to the Air Cleaner Element Replacement in the Periodic Maintenance chapter.

### **Air Cleaner Element Inspection**

- Remove the air cleaner element [A] (see Air Cleaner Element Replacement in the Periodic Maintenance chapter).
- Visually check the element for tears or breaks.
- ★ If the element has any tears or breaks, replace the element.

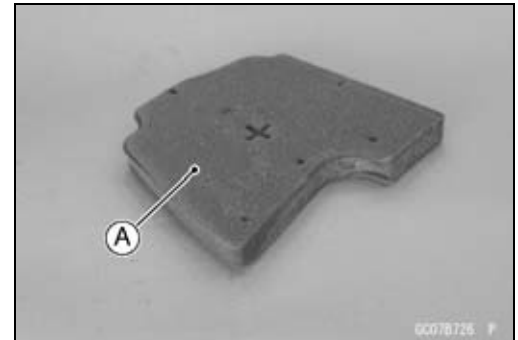

### **Air Cleaner Housing Removal**

- Remove:
  - Middle Fairings (see Middle Fairing Removal in the Frame chapter)
- Slide the clamps [A].
- Disconnect:
  - Breather Hose [B]
  - Drain Hose [C]

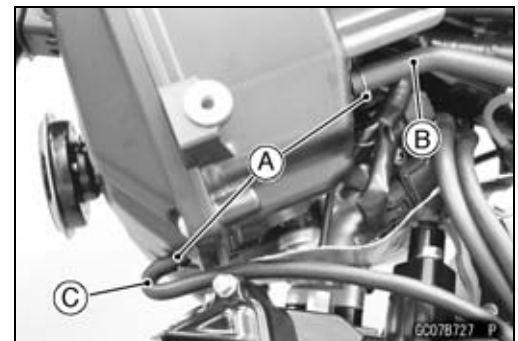

- Disconnect:
  - Horn Lead Connectors [A]
- Remove:
  - Bolt [B]
  - Horn [C]

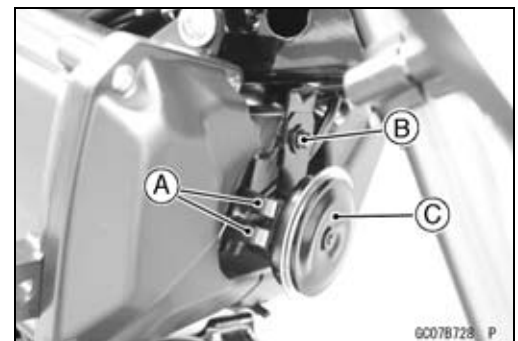

- Open the clamp [A].
- Remove:
  - Air Cleaner Housing Mounting Screw (L = 14 mm) [B] (Both Sides)
  - Washer [C]
  - Air Cleaner Housing Mounting Screw (L = 20 mm) [D]
- Loosen the air cleaner housing clamp screw [E].
- Remove the air cleaner housing [F] forward.
- After removing the air cleaner housing, cover the clean cloth on the throttle body assy.

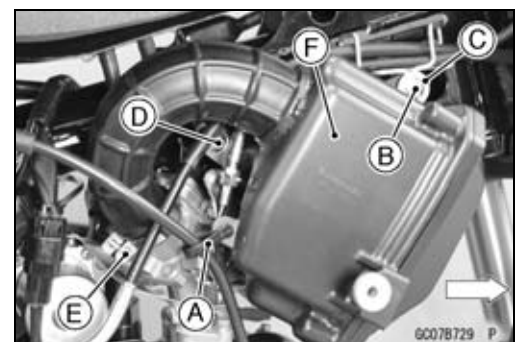

## 3-102 FUEL SYSTEM (DFI)

### Air Cleaner

#### ***Air Cleaner Housing Installation***

- Fit the hole [A] of the clamp to the projection [B] of the holder.
- Install the air cleaner housing on the throttle body assy.
- Tighten the air cleaner housing clamp screw.

**Torque - Air Cleaner Housing Clamp Screw: 2.0 N·m (0.20 kgf·m, 18 in·lb)**

- Tighten:

**Torque - Air Cleaner Housing Mounting Screws (L = 14 mm): 5.2 N·m (0.53 kgf·m, 46 in·lb)**

**Air Cleaner Housing Mounting Screw (L = 20 mm): 3.5 N·m (0.36 kgf·m, 31 in·lb)**

- Run the hoses correctly (see Cable, Wire, and Hose Routing section in the Appendix chapter).
- Install the removed parts (see appropriate chapters).

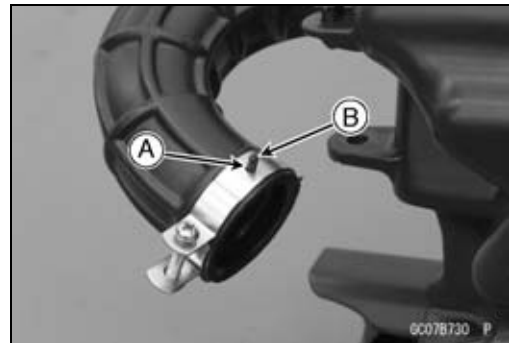

Fuel Tank

Fuel Tank Removal

**⚠ WARNING**

Gasoline is extremely flammable and can be explosive under certain conditions, creating the potential for serious burns. Make sure the area is well ventilated and free from any source of flame or sparks; this includes any appliance with a pilot light. Do not smoke. Turn the ignition switch off. Disconnect the battery (-) terminal. To avoid fuel spills, draw it from the tank when the engine is cold. Be prepared for fuel spillage; any spilled fuel must be completely wiped up immediately.

- Turn the ignition switch off.
- Wait until the engine cools down.
- Disconnect the battery (-) terminal (see Battery Removal in the Electrical System chapter).
- Open the fuel tank cap [A] to lower the pressure in the tank.
- During tank removal, keep the tank cap open to release pressure in the tank. This makes fuel spillage less.



- Draw the fuel out from the fuel tank with a commercially available pump [A].
- Use a soft plastic hose [B] as a pump intake hose in order to insert the hose smoothly.
- Put the hose through the fill opening [C] into the tank and draw the fuel out.

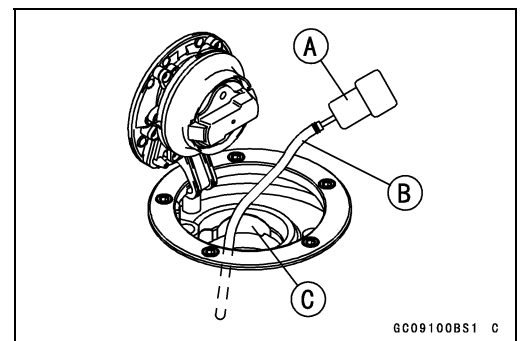

**⚠ WARNING**

Spilled fuel is flammable and can be explosive under certain conditions. The fuel can not be removed completely from the fuel tank. Be careful for remained fuel spillage.

- Remove:
  - Middle Fairings (see Middle Fairing Removal in the Frame chapter)
  - Fuel Tank Cover (see Fuel Tank Cover Removal in the Frame chapter)
  - Fuel Tank Bolts [A]
  - Bracket [B]

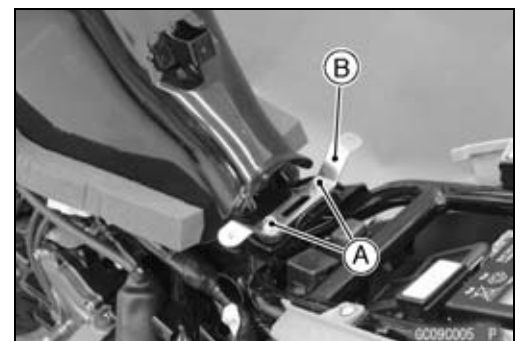

# 3-104 FUEL SYSTEM (DFI)

## Fuel Tank

- Disconnect the fuel pump connector [A].

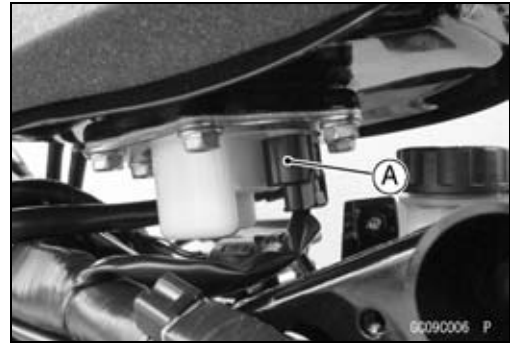

- Be sure to place a piece of cloth around the fuel hose joint.
- Wipe off the dirt of the surface [A] around the connection using a cloth or a soft brush.

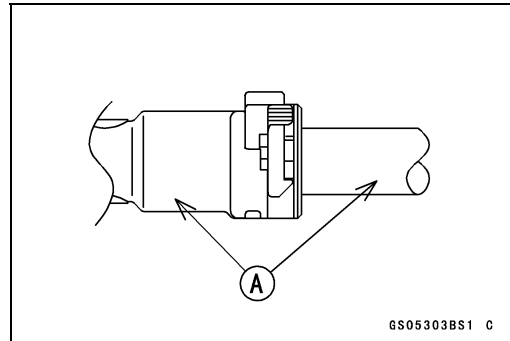

### When removing with flat tip screwdriver

- Insert the flat tip screwdriver [A] into slit on the joint lock [B].
- Turn the driver to disconnect the joint lock.

### When removing with fingers

- Open and push up [C] the joint lock with your fingers.

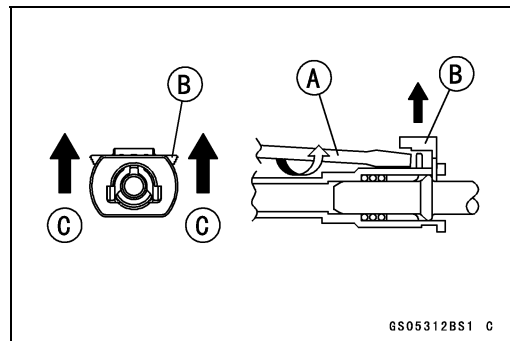

### NOTICE

Prying or excessively widening the joint lock ends for fuel hose removal will permanently deform the joint lock, resulting in a loose or incomplete lock that may allow fuel to leak and create the potential for a fire explosion. To prevent fire or explosion from a damaged joint lock, do not pry or excessively widen the joint lock ends when removing the fuel hose. The joint lock has a retaining edge that locks around the housing.

- Pull the fuel hose joint [A] out of the outlet pipe.

### NOTICE

When removing the fuel hose joint, do not apply strong force to the outlet pipe on the fuel pump. The pipe made from resin could be damaged.

### ⚠ WARNING

Fuel is flammable and explosive under certain conditions and can cause severe burns. Be prepared for fuel spillage; any spilled fuel must be completely wiped up immediately. When the fuel hose is disconnected, fuel spills out from the hose and the pipe because of residual pressure. Cover the hose connection with a piece of clean cloth to prevent fuel spillage.





**Fuel Tank**

- Slide the clamps [A].
- Disconnect:
  - Fuel Breather Hose [B]
  - Fuel Drain Hose [C]

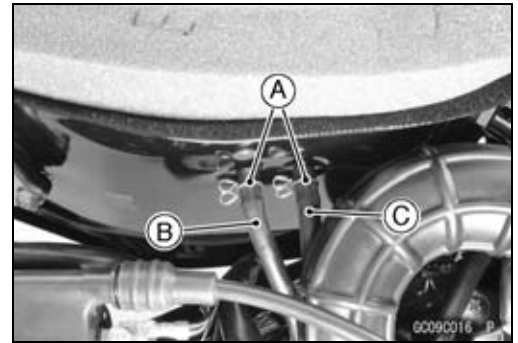

- Close the fuel tank cap.
- Remove the fuel tank [A] rearward to clear the projections [B].

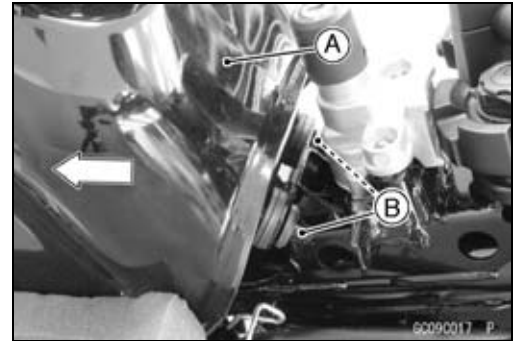

- Place the fuel tank [A] on a planks [B].
- Do not apply the load to the fuel pump outlet portion [C] especially the outlet pipe made from resin.

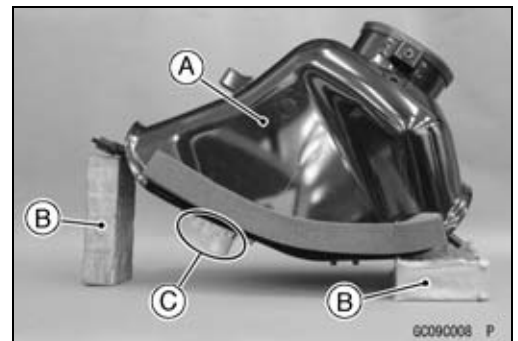

- Clean the pipe [A].
- Cover the pipe and the hose joint [B] with the vinyl bags [C] to keep it clean.

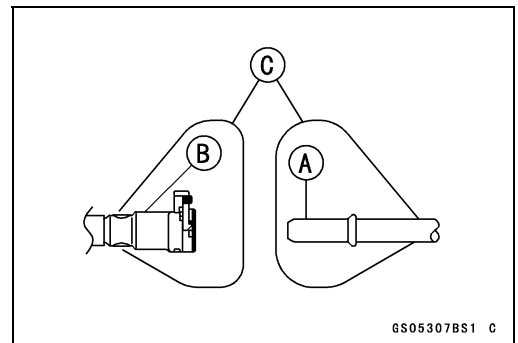

# 3-106 FUEL SYSTEM (DFI)

## Fuel Tank

### Fuel Tank Installation

- Installation is the reverse of removal.
- Note the above WARNING (see Fuel Tank Removal).
- Check that the dampers [A], pads [B] and collars [C] are in place on the frame and the fuel tank.
  - About 2 mm (0.08 in.) [D]
  - About 20 mm (0.79 in.) [E]
  - About 10 mm (0.39 in.) [F]
- ★ If the dampers and pads are damaged or deteriorated, replace them.
- Run the hoses correctly (see Cable, Wire, and Hose Routing section in the Appendix chapter).

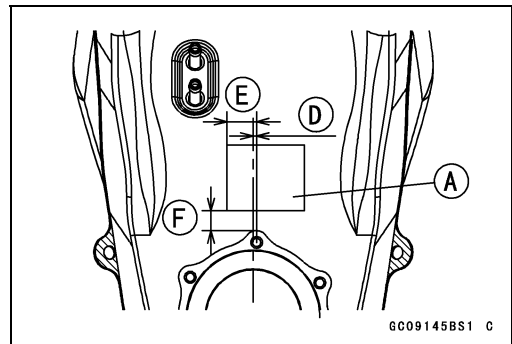
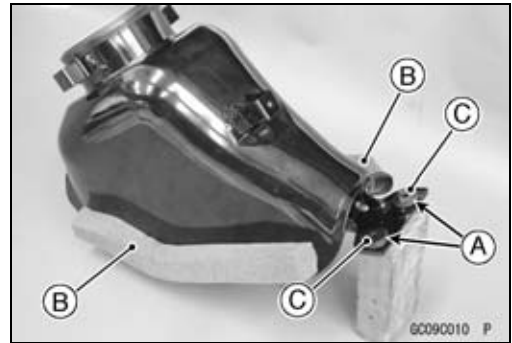
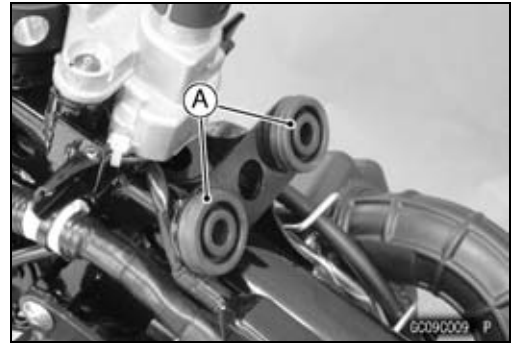

- Remove the vinyl bags on the pipe and fuel hose joint.
- Check the joint lock for deformation and wear.
- ★ If the joint lock is deformed, replace the fuel hose with a new one.
- Check that there are no flaws, burrs, and adhesion of foreign materials on the pipe [A].
- Apply engine oil to the pipe.

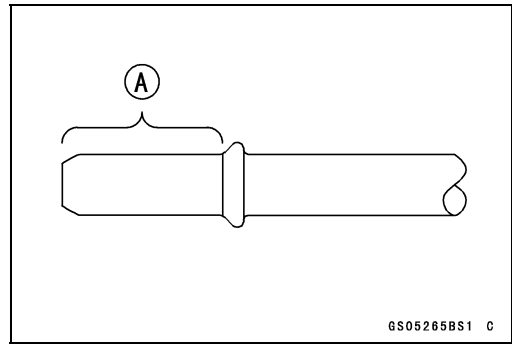

- Insert the projections [A] into the dampers [B].

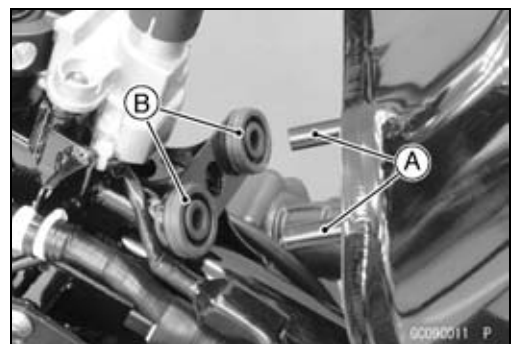

## Fuel Tank

- Insert the fuel hose joint [A] straight onto the fuel outlet pipe until the hose joint clicks.

### NOTICE

**When installing the fuel hose joint, do not apply strong force to the outlet pipe on the fuel pump. The pipe made from resin could be damaged.**

- Push [B] the joint lock [C] until the hose joint clicks.
- Push and pull [A] the hose joint [B] back and forth more than two times, and make sure it is locked and does not come off.

### ⚠ WARNING

**Leaking fuel can cause a fire or explosion resulting in serious burns. Make sure the hose joint is installed correctly on the delivery pipe.**

- ★ If it comes off, reinstall the hose joint.
- Connect the fuel pump connector and the battery (–) terminal (see Battery Installation in the Electrical System chapter).
- Install the removed parts (see appropriate chapters).

### Fuel Tank and Cap Inspection

- Open the tank cap.
- Visually inspect the gasket [A] on the tank cap for any damage.
- ★ Replace the tank cap if gasket is damaged.
- Check to see if the water drain pipe [B] and fuel breather pipe [C] in the tank are not clogged. Check the tank cap breather also.
- ★ If they are clogged, remove the tank and drain it, and then blow the breather free with compressed air.

### NOTICE

**Do not apply compressed air to the air vent holes [D] in the tank cap. This could cause damage and clogging of the labyrinth in the cap.**

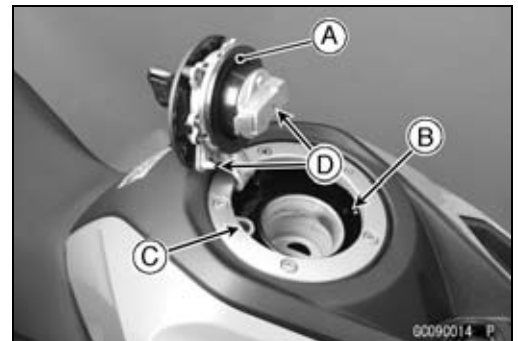
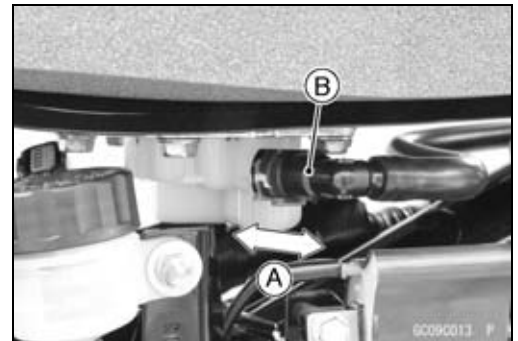
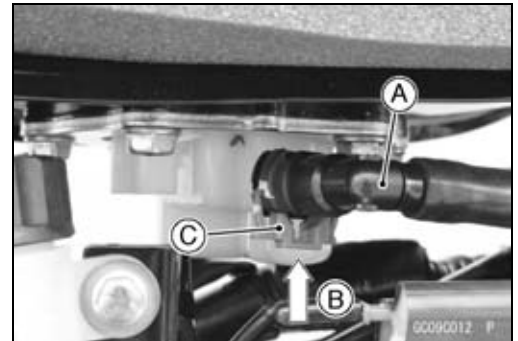

## 3-108 FUEL SYSTEM (DFI)

---

### Fuel Tank

---

#### *Fuel Tank Cleaning*

 <b>WARNING</b>
--

**Gasoline and low flash-point solvents can be flammable and/or explosive and cause severe burns. Clean the tank in a well-ventilated area, and take care that there are no sparks or flame anywhere near the working area. Do not use gasoline or low flash-point solvents to clean the tank.**

- Remove:
  - Fuel Tank (see Fuel Tank Removal)
  - Fuel Pump (see Fuel Pump Removal)
- Pour some high flash-point solvent into the fuel tank and shake the tank to remove dirt and fuel deposits.
- Draw the solvent out of the fuel tank.
- Dry the tank with compressed air.
- Install:
  - Fuel Pump (see Fuel Pump Installation)
  - Fuel Tank (see Fuel Tank Installation)

## Evaporative Emission Control System (CAL Model)

The Evaporative Emission Control System routes fuel vapors from the fuel system into the running engine or stores the vapors in a canister when the engine is stopped. Although no adjustments are required, a thorough visual inspection must be made at the intervals specified by the Periodic Maintenance Chart.

### Parts Removal/Installation

#### **⚠ WARNING**

**Gasoline is extremely flammable and can be explosive under certain conditions. Turn the ignition switch off. Do not smoke. Make sure the area is well ventilated and free from any source of flame or sparks; this includes any appliance with a pilot light.**

#### **NOTICE**

**If gasoline, solvent, water or any other liquid enters the canister, the canister's vapor absorbing capacity is greatly reduced. If the canister does become contaminated, replace it with a new one.**

- Connect the hoses according to the diagram of the system (see Cable, Wire, and Hose Routing section in the Appendix chapter). Make sure they do not get pinched or kinked.

### Hose Inspection

- Refer to the Evaporative Emission Control System Inspection (CAL Model) in the Periodic Maintenance chapter.

### Purge Valve Inspection

- Refer to the Purge Valve Inspection.

### Canister Removal

- Remove the left side/frame cover (see Side/Frame Cover Removal in the Frame chapter).
- Slide the clamp [A].
- Disconnect the hoses [B].

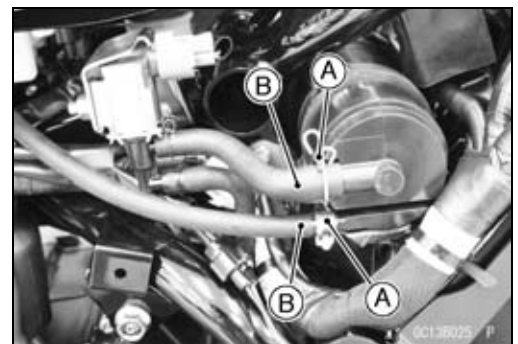

## 3-110 FUEL SYSTEM (DFI)

### Evaporative Emission Control System (CAL Model)

- Remove:
  - Canister Bracket Bolts [A]
  - Clamp [B]
- Remove the canister [C] with the bracket.

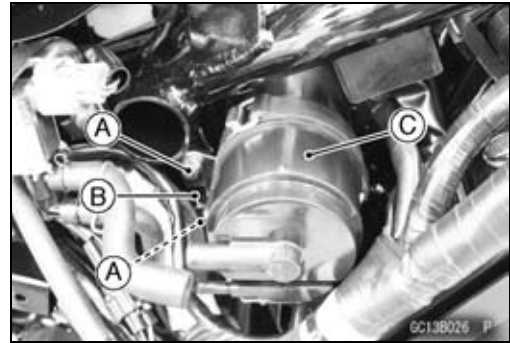

- Remove:
  - Band [A]
  - Bracket [B]
  - Canister [C]



#### **Canister Installation**

- Installation is the reverse of removal.
- Tighten:
  - Torque - Canister Bracket Bolts: 8.8 N·m (0.90 kgf·m, 78 in·lb)**
- Run the leads and hoses correctly (see Cable, Wire and Hose Routing section in the Appendix chapter).

#### **Canister Inspection**

- Refer to the Evaporative Emission Control System Inspection (CAL Model) in the Periodic Maintenance chapter.

# Engine Top End

## Table of Contents

Exploded View .....	4-2	Valves .....	4-24
Exhaust System Identification .....	4-6	Valve Clearance Inspection .....	4-24
Specifications .....	4-8	Valve Clearance Adjustment .....	4-24
Special Tools .....	4-10	Valve Removal .....	4-24
Camshaft Chain Tensioner .....	4-12	Valve Installation .....	4-24
Camshaft Chain Tensioner		Valve Guide Removal .....	4-25
Removal .....	4-12	Valve Guide Installation .....	4-25
Camshaft Chain Tensioner		Valve-to-Guide Clearance	
Installation .....	4-13	Measurement (Wobble	
Camshaft, Camshaft Chain .....	4-14	Method) .....	4-26
Camshaft Removal .....	4-14	Valve Seat Inspection .....	4-27
Camshaft Installation .....	4-14	Valve Seat Repair .....	4-28
Camshaft Inspection .....	4-14	Cylinder, Piston.....	4-33
Camshaft Bearing Inspection.....	4-14	Cylinder Removal.....	4-33
Camshaft Sprocket Removal .....	4-15	Cylinder Installation.....	4-33
Camshaft Sprocket Installation ...	4-16	Piston Removal.....	4-34
Camshaft Sprocket		Piston Installation.....	4-34
Disassembly/Assembly .....	4-17	Cylinder Wear Inspection.....	4-35
KACR Inspection.....	4-17	Piston Wear Inspection .....	4-36
Camshaft Chain Removal.....	4-18	Piston/Cylinder Clearance	
Camshaft Chain Installation.....	4-18	Inspection.....	4-36
Camshaft Chain Guide Wear		Piston Ring, Piston Ring Groove	
Inspection.....	4-18	Wear Inspection .....	4-36
Rocker Arm, Rocker Shaft.....	4-19	Piston Ring Groove Width	
Rocker Arm Removal.....	4-19	Inspection.....	4-37
Rocker Arm Installation.....	4-19	Piston Ring Thickness Inspection	4-37
Rocker Arm and Rocker Shaft		Piston Ring End Gap Inspection ..	4-37
Wear Inspection .....	4-20	Piston, Piston Pin, Connecting	
Cylinder Head.....	4-21	Rod Wear Inspection.....	4-38
Cylinder Compression		Boring, Honing Performance (ID	
Measurement .....	4-21	Model) .....	4-38
Cylinder Head Removal .....	4-22	Muffler.....	4-40
Cylinder Head Installation .....	4-22	Muffler Removal.....	4-40
Cylinder Head Cleaning .....	4-23	Muffler Installation.....	4-40
Cylinder Head Warp Inspection ...	4-23		

# 4-2 ENGINE TOP END

## Exploded View

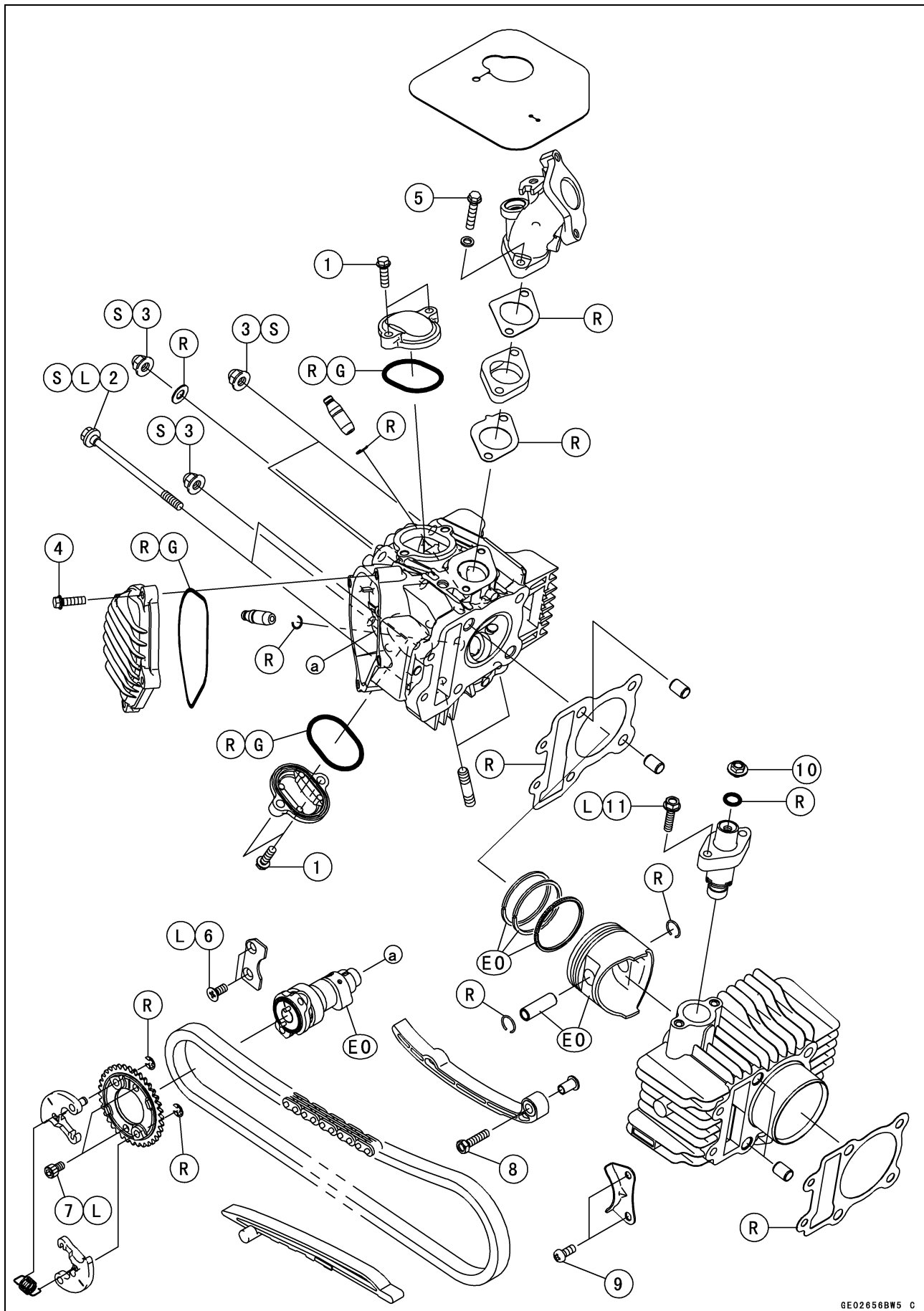



## Exploded View

No.	Fastener	Torque			Remarks
		N·m	kgf·m	ft·lb	
1	Valve Adjusting Cap Bolts	5.2	0.53	46 in·lb	
2	Cylinder Head Bolts	12	1.2	106 in·lb	L, S
3	Cylinder Head Nuts	22	2.2	16	S
4	Camshaft Sprocket Cover Bolts	5.2	0.53	46 in·lb	
5	Intake Pipe Bolts	12	1.2	106 in·lb	
6	Rocker Shaft Stopper Screws	5.2	0.53	46 in·lb	L
7	Camshaft Sprocket Bolts	12	1.2	106 in·lb	L
8	Camshaft Chain Guide Mounting Bolt	5.2	0.53	46 in·lb	
9	Camshaft Chain Holder Screws	5.2	0.53	46 in·lb	
10	Chain Tensioner Cap Bolt	5.2	0.53	46 in·lb	
11	Chain Tensioner Mounting Bolts	5.2	0.53	46 in·lb	L

EO: Apply engine oil.

G: Apply grease.

L: Apply a non-permanent locking agent.

R: Replacement Parts

S: Follow the specified tightening sequence.

# 4-4 ENGINE TOP END

## Exploded View

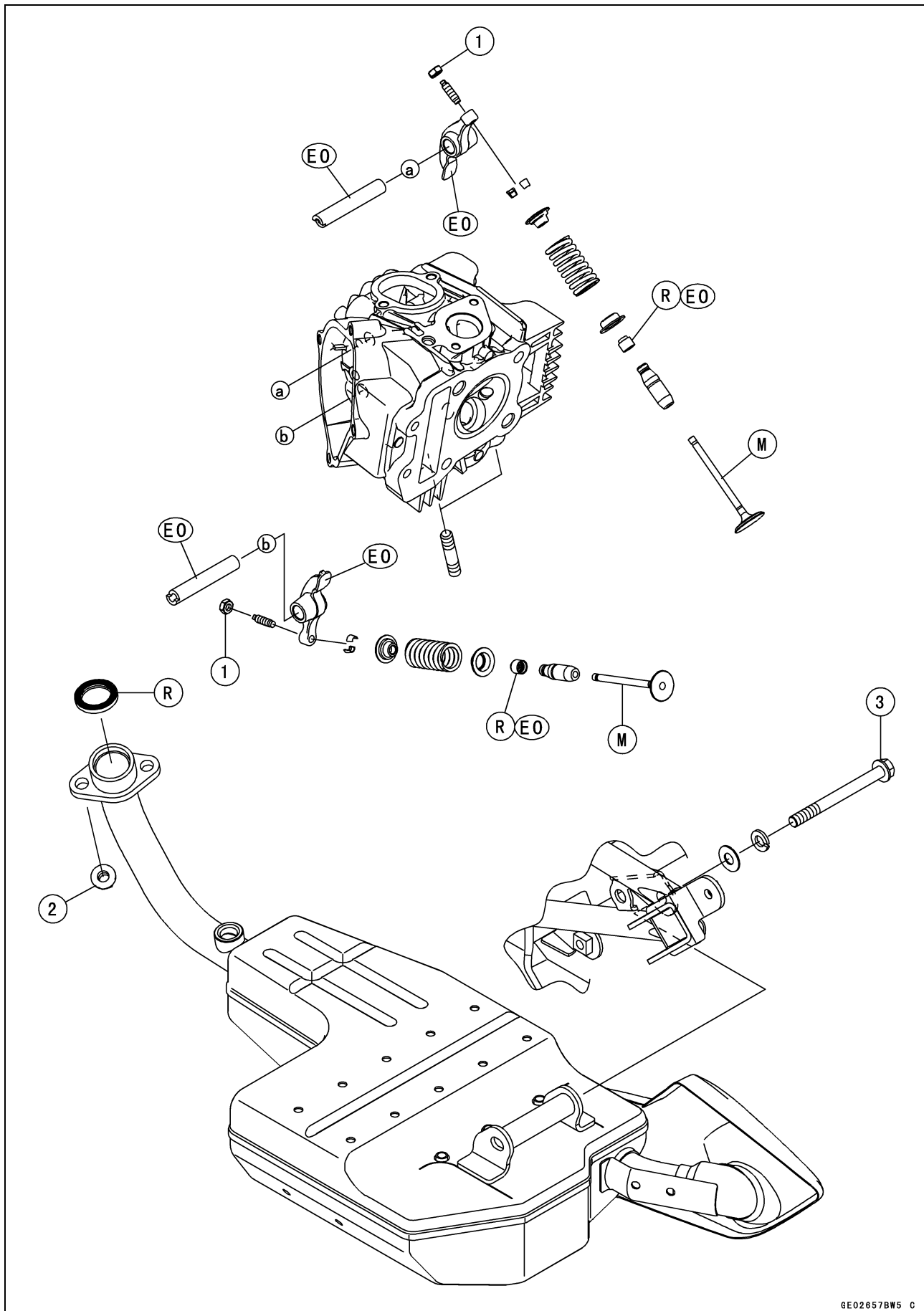

**Exploded View**

<b>No.</b>	<b>Fastener</b>	<b>Torque</b>			<b>Remarks</b>
		<b>N·m</b>	<b>kgf·m</b>	<b>ft·lb</b>	
1	Valve Adjusting Screw Locknuts	8.8	0.90	78 in·lb	
2	Exhaust Pipe Holder Nuts	14.7	1.50	10.8	
3	Muffler Body Mounting Bolt	16.5	1.68	12.2	

EO: Apply engine oil.

M: Apply molybdenum disulfide grease.

R: Replacement Parts

# 4-6 ENGINE TOP END

## Exhaust System Identification

MUFFLER	SPECIFICATION	MODEL
<p><b>Honeycomb Type Catalyst with Oxygen Sensor</b></p> <hr/> <p>P/No : 49070-0810 Mark : KHI K 652</p>	<p>PH TH ID MY</p>	<p>BR125GG BR125GG/HG BR125HG BR125HG</p>
<p><b>Honeycomb Type Catalyst with Oxygen Sensor</b></p> <hr/> <p>P/No : 49070-0812 Mark : KHI K 654</p>	<p>AU CA US CAL</p>	<p>BR125JH BR125JH BR125JH BR125JH</p>

GE24517C F

Muffler Mark Position [A]

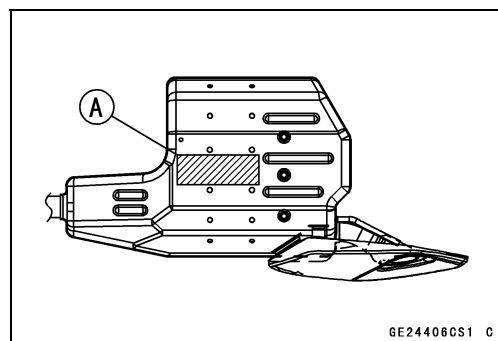

Honeycomb Type Catalyst Position [A] (BR125H/G)

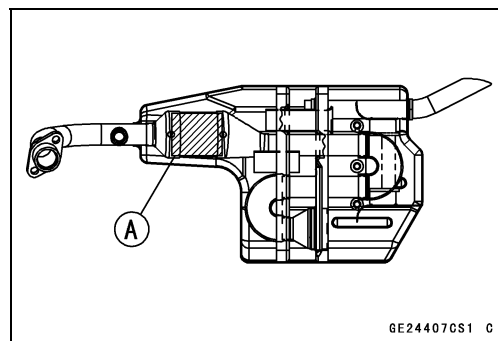

Honeycomb Type Catalyst Positions [A] (BR125J)

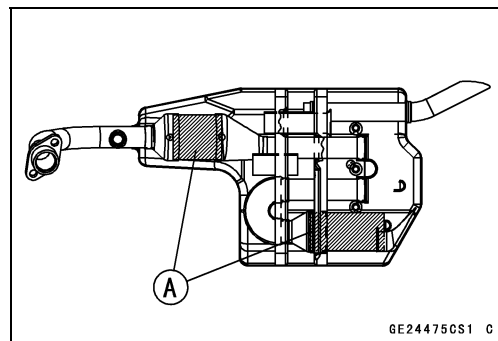

Exhaust System Identification

Oxygen Sensor [A]

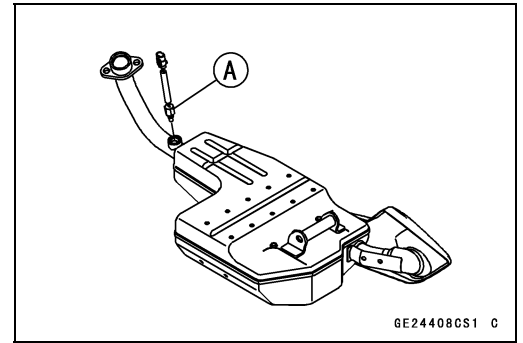

## 4-8 ENGINE TOP END

### Specifications

Item	Standard	Service Limit
<b>Rocker Arm, Rocker Arm Shaft</b>		
Rocker Arm Inside Diameter	10.000 ~ 10.015 mm (0.39370 ~ 0.39429 in.)	10.05 mm (0.3957 in.)
Rocker Shaft Outside Diameter	9.980 ~ 9.995 mm (0.3929 ~ 0.3935 in.)	9.95 mm (0.392 in.)
<b>Camshaft</b>		
Cam Height:		
Exhaust	29.251 ~ 29.365 mm (1.1516 ~ 1.1561 in.)	29.15 mm (1.148 in.)
Intake	29.213 ~ 29.327 mm (1.1501 ~ 1.1546 in.)	29.11 mm (1.146 in.)
<b>Cylinder Head</b>		
Cylinder Compression:	(Usable Range) 294 ~ 518 kPa (3.0 ~ 5.3 kgf/cm <sup>2</sup> , 43 ~ 75 psi) @400 r/min (rpm)	— — —
Cylinder Head Warp	— — —	0.03 mm (0.001 in.)
<b>Valve</b>		
Valve Clearance:		
Exhaust	0.08 ~ 0.12 mm (0.0031 ~ 0.0047 in.)	— — —
Intake	0.04 ~ 0.08 mm (0.0016 ~ 0.0031 in.)	— — —
Valve Head Thickness:		
Exhaust	1.15 ~ 1.45 mm (0.0453 ~ 0.0571 in.)	0.5 mm (0.020 in.)
Intake	0.85 ~ 1.15 mm (0.0335 ~ 0.0453 in.)	0.5 mm (0.020 in.)
Valve Stem Bend	TIR 0.01 mm (0.0004 in.) or less	TIR 0.05 mm (0.002 in.)
Valve Stem Diameter:		
Exhaust	4.462 ~ 4.472 mm (0.1757 ~ 0.1761 in.)	4.44 mm (0.175 in.)
Intake	4.475 ~ 4.490 mm (0.1762 ~ 0.1768 in.)	4.46 mm (0.176 in.)
Valve Guide Inside Diameter:		
Exhaust/Intake	4.500 ~ 4.512 mm (0.1772 ~ 0.1776 in.)	4.58 mm (0.180 in.)
Valve/Valve Guide Clearance (Wobble Method):		
Exhaust	0.06 ~ 0.11 mm (0.0024 ~ 0.0043 in.)	0.25 mm (0.0098 in.)
Intake	0.02 ~ 0.08 mm (0.0008 ~ 0.0031 in.)	0.22 mm (0.0087 in.)
Valve Seat Cutting Angle	32°, 45°, 60°, 67.5°	— — —
Valve Seat Surface:		
Outside Diameter:		
Exhaust	19.9 ~ 20.1 mm (0.783 ~ 0.791 in.)	— — —
Intake	22.9 ~ 23.1 mm (0.902 ~ 0.909 in.)	— — —
Width:		
Exhaust/Intake	0.80 ~ 1.15 mm (0.031 ~ 0.045 in.)	— — —
Valve Spring Free Length:		
Exhaust/Intake	36.8 mm (1.45 in.)	35.5 mm (1.40 in.)

**Specifications**

<b>Item</b>	<b>Standard</b>	<b>Service Limit</b>
<b>Cylinder, Piston</b>		
Cylinder Inside Diameter	55.986 ~ 55.998 mm (2.2042 ~ 2.2046 in.) and less than 0.01 mm (0.0004 in.) difference between any two measurements	56.09 mm (2.208 in.) or 0.05 mm (0.002 in.) difference between any two measurements
Piston Diameter	55.970 ~ 55.982 mm (2.2035 ~ 2.2040 in.)	55.82 mm (2.198 in.)
Piston/Cylinder Clearance	0.011 ~ 0.023 mm (0.00043 ~ 0.00091 in.)	— — —
Oversize Piston and Rings (ID Model)	+0.5 mm (0.020 in.)	— — —
	+1.0 mm (0.039 in.)	— — —
Piston Ring/Groove Clearance:		
Top	0.02 ~ 0.06 mm (0.0008 ~ 0.0024 in.)	0.16 mm (0.0063 in.)
Second	0.01 ~ 0.05 mm (0.0004 ~ 0.0020 in.)	0.15 mm (0.0059 in.)
Piston Ring Groove Width:		
Top	0.81 ~ 0.83 mm (0.0319 ~ 0.0327 in.)	0.91 mm (0.036 in.)
Second	0.80 ~ 0.82 mm (0.0315 ~ 0.0323 in.)	0.90 mm (0.035 in.)
Piston Ring Thickness:		
Top/Second	0.77 ~ 0.79 mm (0.0303 ~ 0.0311 in.)	0.70 mm (0.028 in.)
Piston Ring End Gap:		
Top	0.15 ~ 0.30 mm (0.0059 ~ 0.0118 in.)	0.6 mm (0.02 in.)
Second	0.30 ~ 0.45 mm (0.0118 ~ 0.0177 in.)	0.8 mm (0.03 in.)
Piston Pin Hole Diameter	13.001 ~ 13.007 mm (0.51185 ~ 0.51209 in.)	13.08 mm (0.5150 in.)
Piston Pin Diameter	12.995 ~ 13.000 mm (0.51161 ~ 0.51181 in.)	12.96 mm (0.5102 in.)
Connecting Rod Small End Inside Diameter	13.003 ~ 13.014 mm (0.51193 ~ 0.51236 in.)	13.05 mm (0.5138 in.)

# 4-10 ENGINE TOP END

## Special Tools

Compression Gauge, 20 kgf/cm<sup>2</sup>:

57001-221

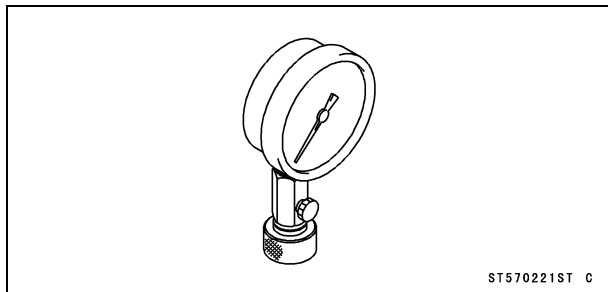

Valve Seat Cutter, 60° -  $\phi$ 30:

57001-1123

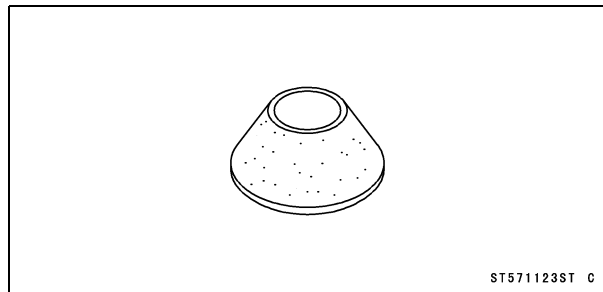

Valve Spring Compressor Assembly:

57001-241

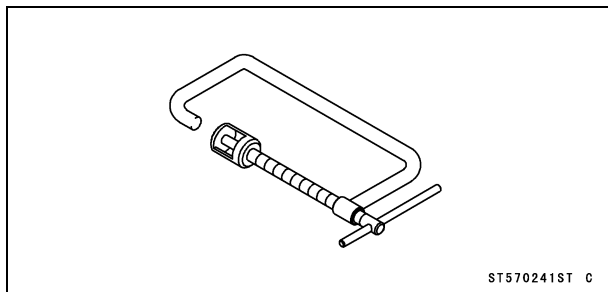

Valve Seat Cutter Holder Bar:

57001-1128

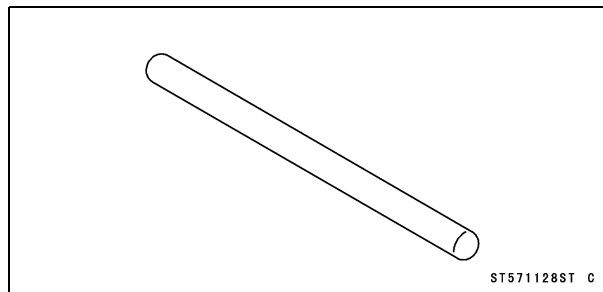

Piston Pin Puller Assembly:

57001-910

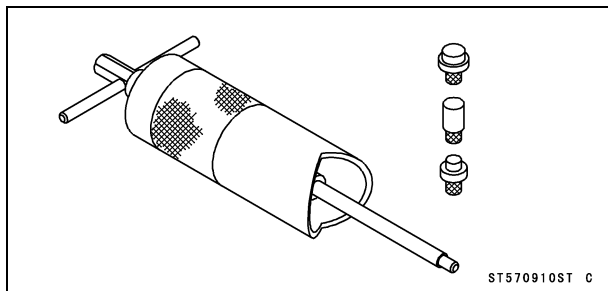

Valve Spring Compressor Adapter,  $\phi$ 20:

57001-1154

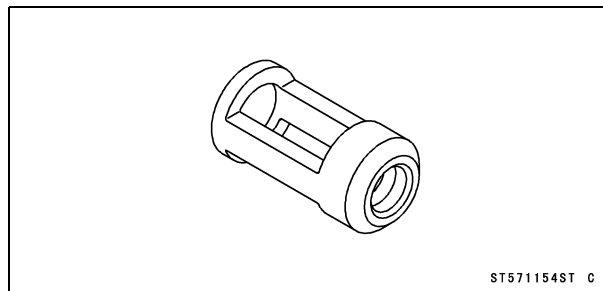

Valve Seat Cutter, 45° -  $\phi$ 27.5:

57001-1114

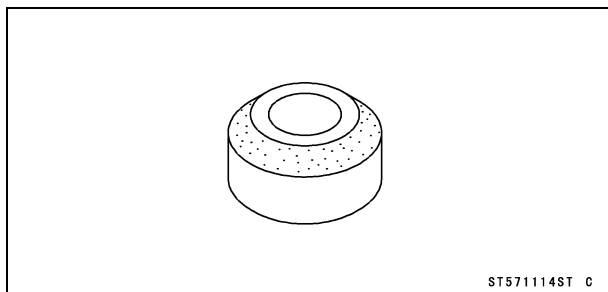

Valve Seat Cutter, 45° -  $\phi$ 22:

57001-1205

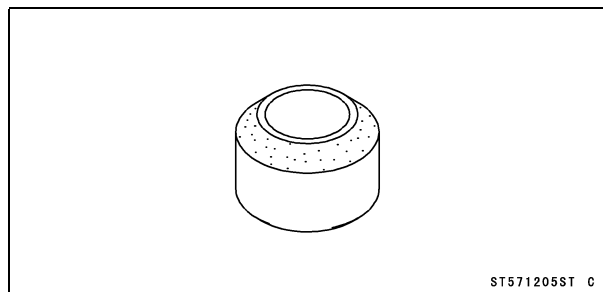

Valve Seat Cutter, 32° -  $\phi$ 25:

57001-1118

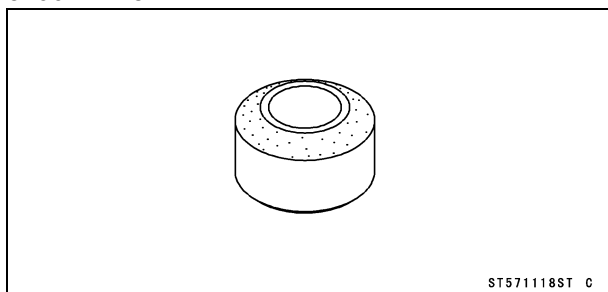

Valve Seat Cutter, 32° -  $\phi$ 22:

57001-1206

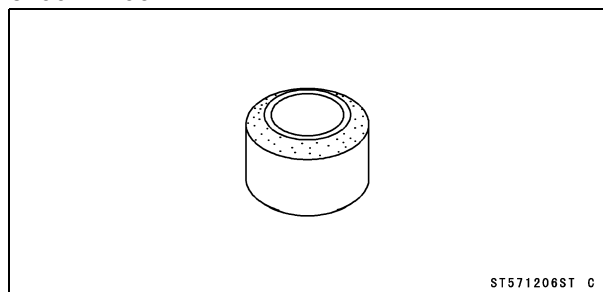



Special Tools

Valve Seat Cutter, 67.5° -  $\phi$ 22:  
57001-1207

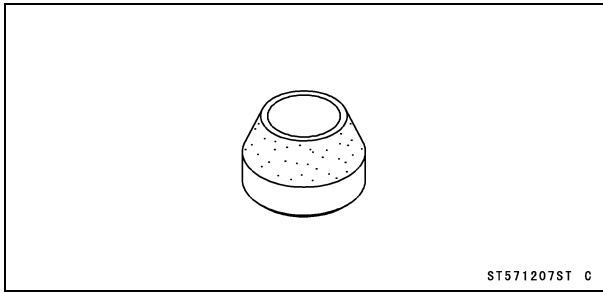

ST571207ST C

Valve Guide Reamer,  $\phi$ 4.5:  
57001-1333

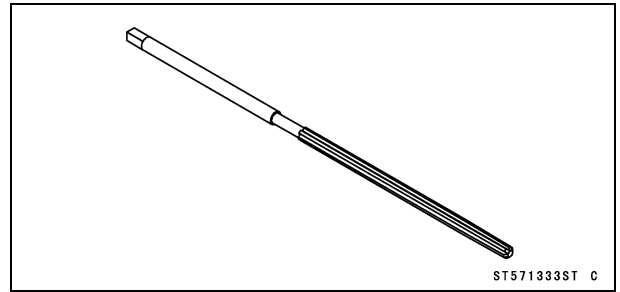

ST571333ST C

Valve Seat Cutter Holder,  $\phi$ 4.5:  
57001-1330

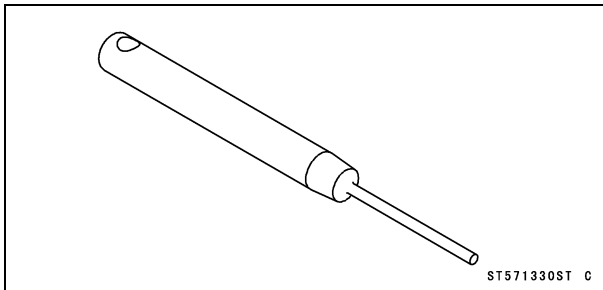

ST571330ST C

Compression Gauge Adapter, M10 × 1.0:  
57001-1486

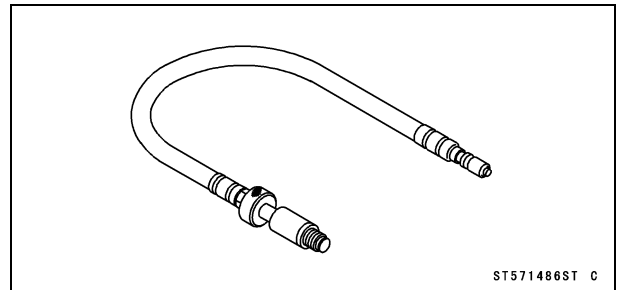

ST571486ST C

Valve Guide Arbor,  $\phi$ 4.5:  
57001-1331

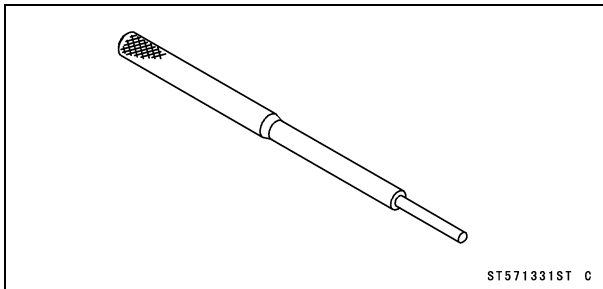

ST571331ST C

## 4-12 ENGINE TOP END

### Camshaft Chain Tensioner

#### Camshaft Chain Tensioner Removal

##### NOTICE

This is a non-return type camshaft chain tensioner. The push rod does not return to its original position once it moves out to take up camshaft chain slack. Observe all the rules listed below.

When removing the tensioner, do not take out the mounting bolts only halfway. Retightening the mounting bolts from this position could damage the tensioner and the camshaft chain. Once the bolts are loosened, the tensioner must be removed and reset as described in "Camshaft Chain Tensioner Installation." Do not turn over the crankshaft while the tensioner is removed. This could upset the camshaft chain timing, and damage the valves.

- Remove:
  - Air Cleaner Housing (see Air Cleaner Housing Removal in the Fuel System (DFI) chapter)
  - Starter Motor Mounting Screw [A]
  - Clamp [B]
- Disconnect the throttle body assy sensors connector [C].

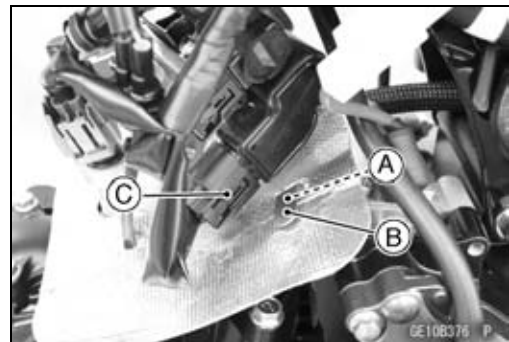

- Remove the chain tensioner cap bolt [A] and chain tensioner mounting bolt [B].
- Loosen the chain tensioner mounting bolt [C] fully.

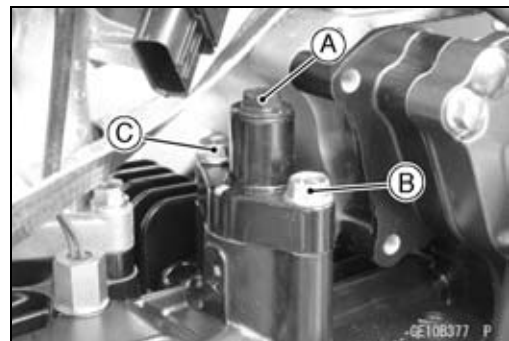

- While turning the push rod clockwise with a flat tip screwdriver [A], remove the tensioner [B] with chain tensioner mounting bolt [C].

##### NOTE

○The tensioner can not be removed in a state where the push rod is extended.

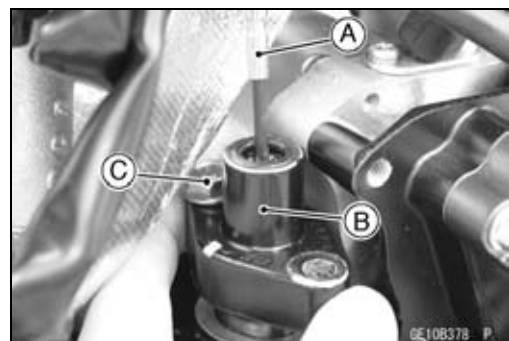

## Camshaft Chain Tensioner

### Camshaft Chain Tensioner Installation

- Turn the push rod clockwise [A] with a flat tip screwdriver [B], until the protruded length [C] becomes to about 10 mm (0.39 in.).

#### NOTICE

**Do not turn the rod counterclockwise at installation. This could detach the rod and the tensioner cannot be reinstalled.**

- Insert a suitable holder plate [A] to hold compression of the rod.
  - 8.5 mm (0.33 in.) [B]
  - 3.5 mm (0.14 in.) [C]
  - 7 mm (0.28 in.) [D]
  - 16 mm (0.63 in.) [E]

#### NOTE

○ To make the procedure easy, use a holder plate to keep the rod from pushing out. A replacement chain tensioner (spare parts) has a holder plate. The holder plate can be made less than 1 mm (0.04 in.) thick steel plate as shown.

- Apply a non-permanent locking agent to the chain tensioner mounting bolts.
- Install the chain tensioner mounting bolt [A] to the right chain tensioner mounting hole.
- Install the chain tensioner [B] with the chain tensioner mounting bolt.
- Install the chain tensioner so that the mark [C] faces to the forward.

- Tighten:
  - Torque - Chain Tensioner Mounting Bolts [A]: 5.2 N·m (0.53 kgf·m, 46 in·lb)**
- Remove the holder plate [B].
- Replace the O-ring with a new one.
- Install the new O-ring and tighten the chain tensioner cap bolt.
  - Torque - Chain Tensioner Cap Bolt: 5.2 N·m (0.53 kgf·m, 46 in·lb)**
- Install the removed parts (see appropriate chapters).

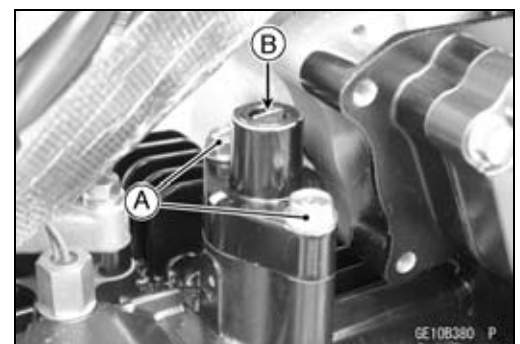
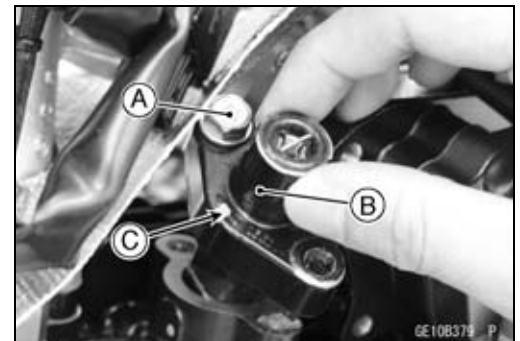
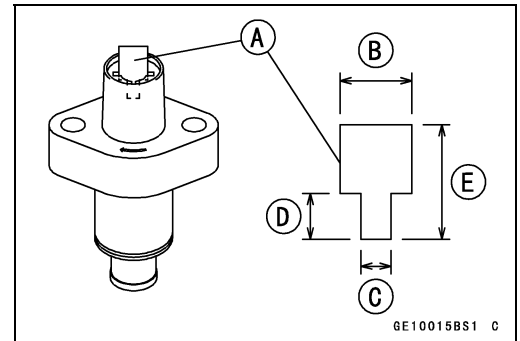
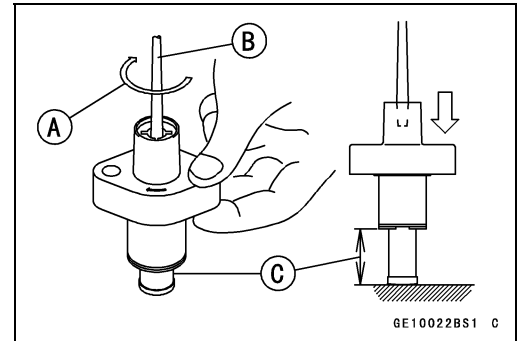

## 4-14 ENGINE TOP END

### Camshaft, Camshaft Chain

#### Camshaft Removal

- Remove:
  - Rocker Arms (see Rocker Arm Removal)
  - Camshaft [A]

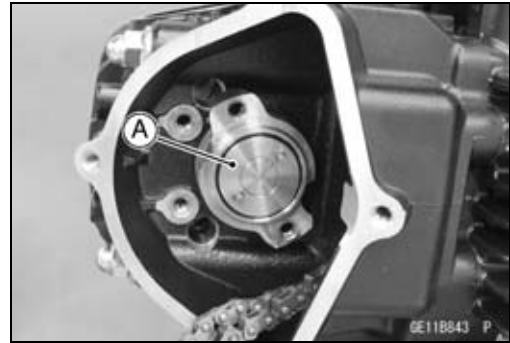

#### Camshaft Installation

- Clean the camshaft with high flash-point solvent.
- Apply engine oil to all cam parts.
- Install the camshaft into the cylinder head.
- Install the removed parts (see appropriate chapters).
- Check and adjust the valve clearance (see Valve Clearance Inspection in the Periodic Maintenance chapter).

#### Camshaft Inspection

- Visually inspect the cam for wear or damage.
- ★ If there is any damage or wear, replace the camshaft.
- Measure the height [A] of each cam.

##### Cam Height

###### Standard:

Exhaust 29.251 ~ 29.365 mm (1.1516 ~ 1.1561 in.)

Intake 29.213 ~ 29.327 mm (1.1501 ~ 1.1546 in.)

###### Service Limit:

Exhaust 29.15 mm (1.148 in.)

Intake 29.11 mm (1.146 in.)

- ★ If any cam falls below the service limit, replace the camshaft.

#### Camshaft Bearing Inspection

- Visually inspect the camshaft bearing [A].
- ★ If there is any damage, replace the camshaft.
- Turn the bearing back and forth while checking for roughness or binding.
- ★ If roughness or binding is found, replace the camshaft.
- ★ If it is noisy, does not spin smoothly, or has any rough spots, replace the camshaft.

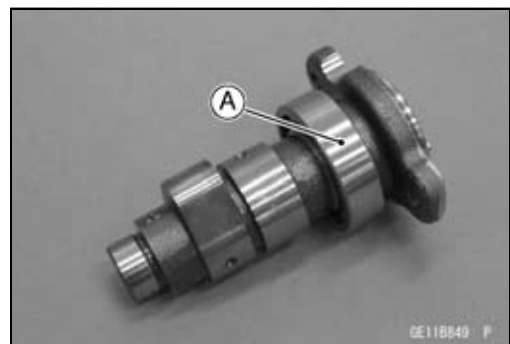
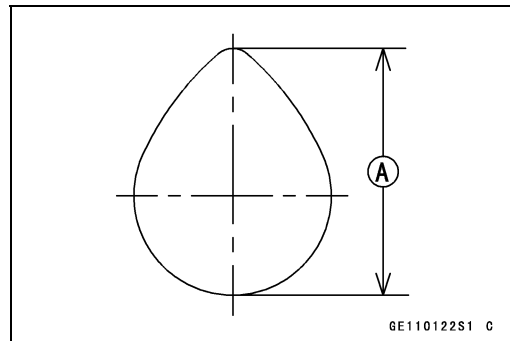

## Camshaft, Camshaft Chain

### Camshaft Sprocket Removal

- Remove:
  - Alternator Rotor Nut Cap [A]
  - Timing Inspection Cap [B]
- Turn the alternator rotor nut counterclockwise and align the "T" mark line [A] on the rotor with the projection [B] of the alternator cover.
- Remove the camshaft chain tensioner (see Camshaft Chain Tensioner Removal).
- Remove:
  - Camshaft Sprocket Cover Bolts [A]
  - Camshaft Sprocket Cover [B]
- With a wrench on the alternator rotor nut to keep the crankshaft from turning, remove the camshaft sprocket bolts [A].

#### **NOTICE**

**Always strain the camshaft chain while turning the crankshaft when the camshaft chain is loose. This avoids kinking the chain on the lower (crankshaft) sprocket. A kinked chain could damage both the chain and the sprocket.**

- Remove the camshaft sprocket, and disengage the chain.
  - Using a suitable tool or wire to keep the chain from falling down into the cylinder block.

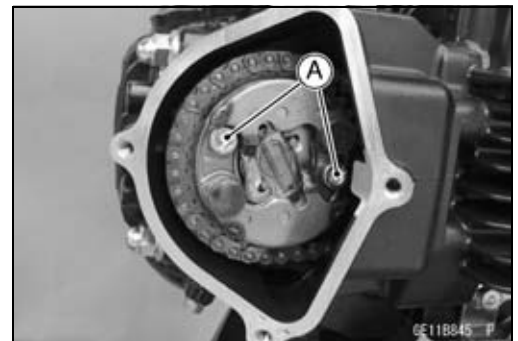
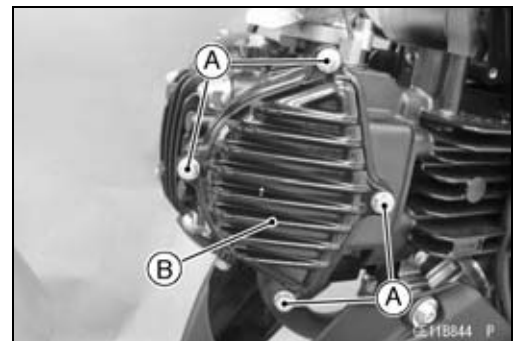
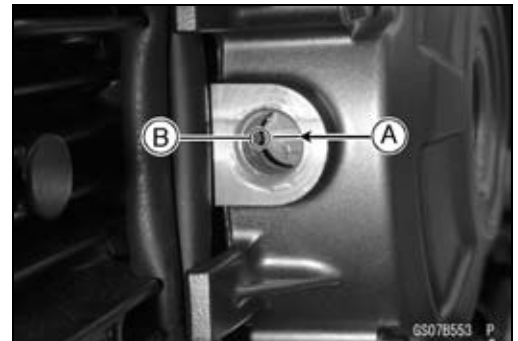
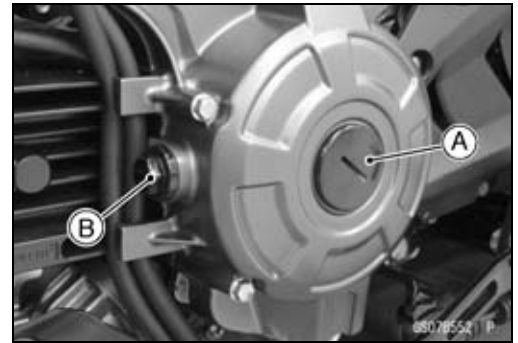

## 4-16 ENGINE TOP END

### Camshaft, Camshaft Chain

#### Camshaft Sprocket Installation

- Position the piston at TDC.
- Turn the alternator rotor nut counterclockwise and align the “T” mark line [A] on the rotor with the projection [B] of the alternator cover.

#### NOTE

- To prevent twining, strain the camshaft chain before rotating the alternator rotor.

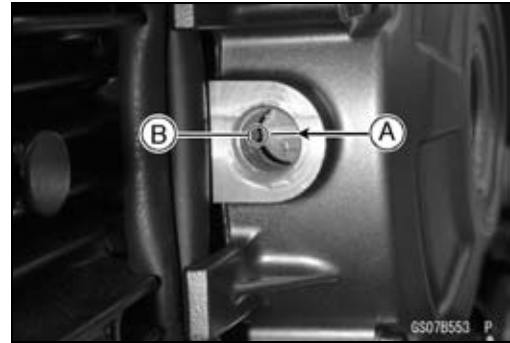

- Install the sprocket so that the mark line [A] of the camshaft sprocket aligns with the projection [B] of the cylinder head.
- Hook the arms [C] on the sprocket so that the unit fits onto the camshaft pins [D].

#### NOTE

- While installing the sprocket, strain the lower side of the camshaft chain.

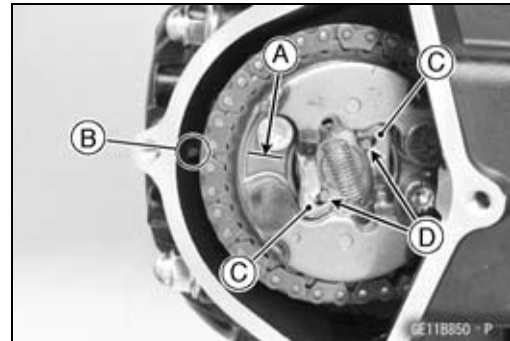

- Apply a non-permanent locking agent to the camshaft sprocket bolts.
- While a wrench on the alternator rotor nut to keep the crankshaft from turning, tighten the camshaft sprocket bolts.

**Torque - Camshaft Sprocket Bolts: 12 N·m (1.2 kgf·m, 106 in·lb)**

- Install the camshaft chain tensioner (see Camshaft Chain Tensioner Installation).
- Check the camshaft chain timing.
- Turn the alternator rotor two turns in the counterclockwise, the crankshaft is at TDC, and recheck the camshaft chain timing.
- ★ If the timing mark is aligned, the camshaft chain timing is correct.

#### NOTICE

**Rotation of the alternator rotor with improper camshaft timing could cause the valve to contact each other or the piston, and bend.  
If any resistance is felt when turning the alternator rotor, stop immediately, and check the camshaft chain timing.**

- Replace the O-ring [A] with a new one.
- Apply grease to the new O-ring and install the camshaft sprocket cover [B].
- Tighten:  
**Torque - Camshaft Sprocket Cover Bolts [C]: 5.2 N·m (0.53 kgf·m, 46 in·lb)**
- Install the removed parts (see appropriate chapters).

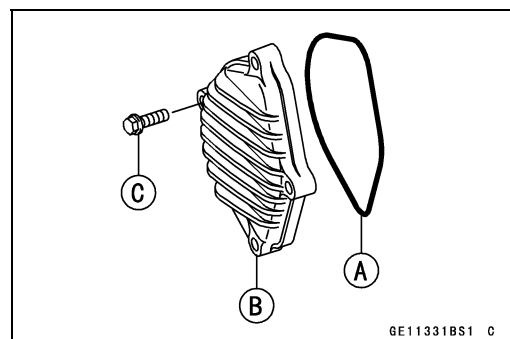

## Camshaft, Camshaft Chain

### Camshaft Sprocket Disassembly/Assembly

- Remove:
  - Camshaft Sprocket (see Camshaft Sprocket Removal)
  - Circlips [A]
  - Weights [B]
  - Spring [C]
- Assembly is the reverse of disassembly.
- Replace the circlips with new ones.
- Hook the spring from the outside with the open side of the hook inwards.

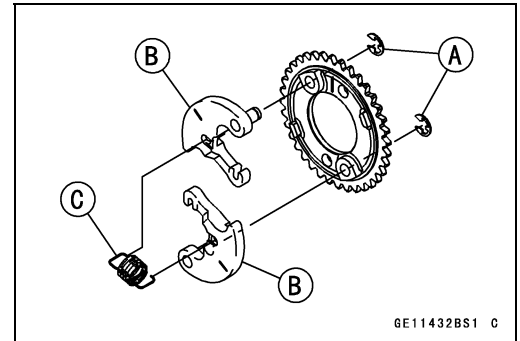

### KACR Inspection

The Kawasaki Automatic Compression Release (KACR) momentarily opens the exhaust valve on the compression stroke at very low speeds. This allows some of the compression pressure to escape, making it easy to turn over the engine during starting.

Due to the simplicity of the mechanism, no periodic maintenance is needed. There are only two symptoms of problems in the KACR mechanism: compression is not released during starting, and compression is released during running.

(1) If compression is not released during starting, the weights are not returning to their rest position.

- Remove the camshaft (see Camshaft Removal).
- Remove the KACR unit.
- Visually inspect the spring.
- ★ If damaged, deformed, or missing, replace the spring.
- Remove the spring and move the weights back and forth.
- ★ If the weights do not move smoothly, replace the KACR unit. Also inspect the exhaust rocker arm for any damage, and replace the rocker arm if necessary.

Rest Position (compression is released) [A]

Weights [B]

Spring [C]

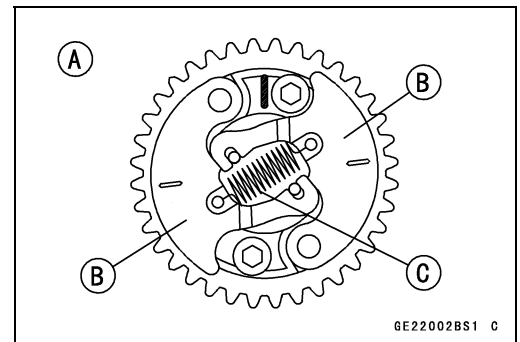
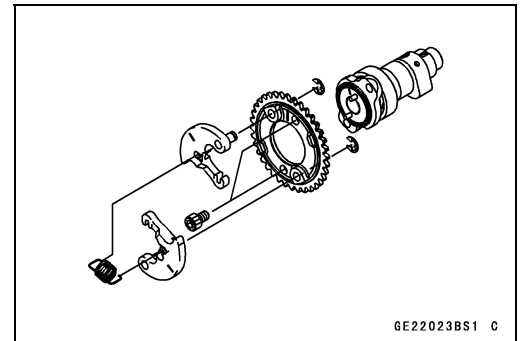

(2) If compression is released while the engine is running, the weights are not swinging out.

- Remove the spring and move the weights back and forth.
- ★ If the weights do not move easily from the retracted position, replace the KACR unit. Also inspect the exhaust rocker arm for any damage, and replace the rocker arm if necessary.

Running Position (compression is not released) [A]

Weights [B]

Spring [C]

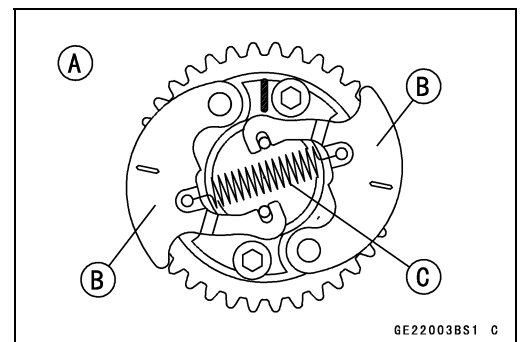

## 4-18 ENGINE TOP END

### Camshaft, Camshaft Chain

#### Camshaft Chain Removal

- Drain the engine oil (see Engine Oil Change in the Periodic Maintenance chapter).
- Remove:
  - Cylinder Head (see Cylinder Head Removal)
  - Alternator Rotor (see Alternator Rotor Removal in the Electrical System chapter)
  - Starter Motor Idle Gear
  - Torque Limiter [A]
  - Starter Motor Clutch Gear [B]
- Remove the camshaft chain holder screws [A] and holder [B].
- Remove the lower chain guide [C] forward.
- Disengage and remove the camshaft chain [D].
- Remove the camshaft chain guide mounting bolt [E] and upper chain guide [F].

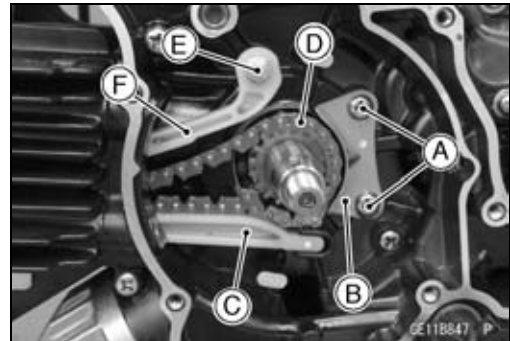
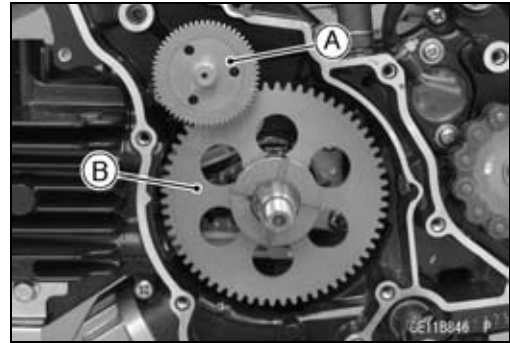

#### Camshaft Chain Installation

- Install the collar [A] to the upper camshaft chain guide [B] as shown.
- Install the upper camshaft chain guide.
- Tighten:
  - Torque - Camshaft Chain Guide Mounting Bolt [C]: 5.2 N·m (0.53 kgf·m, 46 in·lb)
- Engage the camshaft chain to the crankshaft and it is pulled up to the camshaft sprocket pass through camshaft chain hole of the cylinder.
- Keep the chain.
- Install the camshaft chain holder [A].
- Tighten:
  - Torque - Camshaft Chain Holder Screws [B]: 5.2 N·m (0.53 kgf·m, 46 in·lb)
- Insert the lower chain guide [C] securely as shown.
- Install the removed parts (see appropriate chapters).

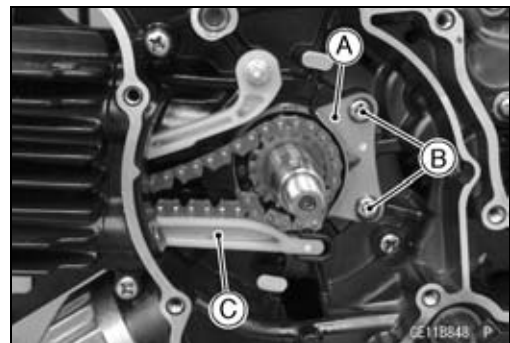
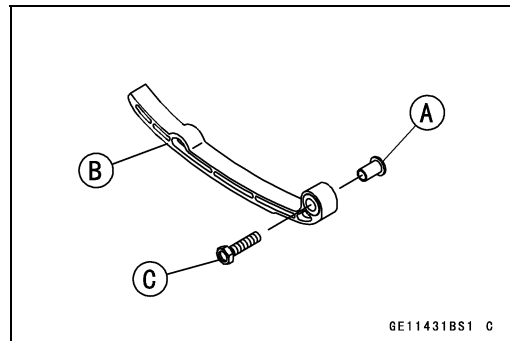

#### Camshaft Chain Guide Wear Inspection

- Visually inspect the guides.
- ★ If the guide is damaged, replace the guide.



## Rocker Arm, Rocker Shaft

### Rocker Arm Removal

- Remove:
  - Camshaft Sprocket (see Camshaft Sprocket Removal)
  - Valve Adjusting Caps [A] (see Valve Clearance Inspection in the Periodic Maintenance chapter)

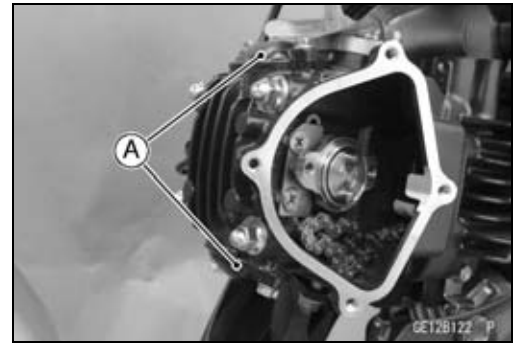

- Remove:
  - Rocker Shaft Stopper Screws [A]
  - Rocker Shaft Stopper [B]

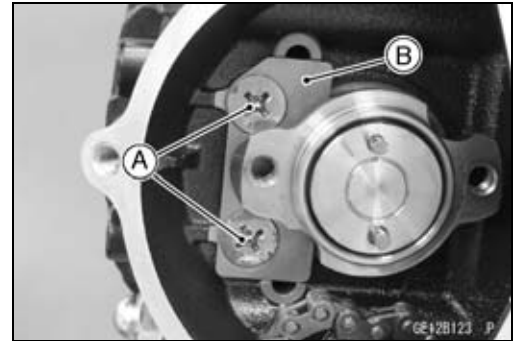

- While holding the rocker arm [A] with hand, remove the rocker shaft [B] and rocker arm.

### NOTE

- Mark and record the rocker arm locations so that the rocker arm can be reinstalled in their original positions.
- The cylinder head has warped by tightening the cylinder head nuts. To remove the rocker shafts easily, loosen the cylinder head nuts.

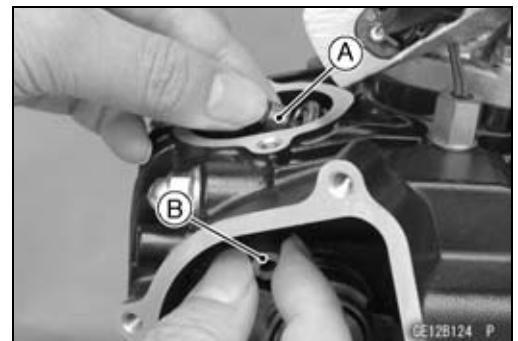

### Rocker Arm Installation

- Clean the rocker arms and rocker shafts with high flash -point solvent.
- Apply engine oil to the rocker shaft outside and the rocker arm cam parts.
- Turn the camshaft so that the cam lobes point downward.
- Install each rocker shaft to the cylinder head, running it through each rocker arm.
- Apply a non-permanent locking agent to the rocker shaft stopper screws [A].
- Install the rocker shaft stopper [B] so that each rocker shaft notch [C] face to face.
- Tighten:

**Torque - Rocker Shaft Stopper Screws: 5.2 N·m (0.53 kgf·m, 46 in·lb)**

- Install the camshaft sprocket (see Camshaft Sprocket Installation).
- Check and adjust the valve clearance (see Valve Clearance Inspection in the Periodic Maintenance chapter).

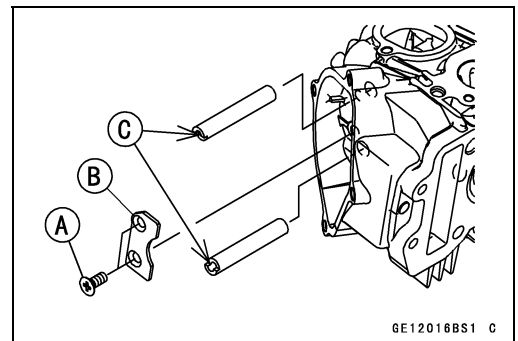

## 4-20 ENGINE TOP END

### Rocker Arm, Rocker Shaft

- Replace the O-ring [A] with a new one.
- Apply grease to the new O-ring and install the valve adjusting cap [B].
- Tighten:  
Torque - Valve Adjusting Cap Bolts [C]: 5.2 N·m (0.53 kgf·m, 46 in·lb)

#### NOTICE

When install the valve adjusting caps, be careful not to drop or protrude the O-rings from the cover grooves. If the O-ring is installed improperly, oil will leak.

- Install the removed parts (see appropriate chapters).

#### Rocker Arm and Rocker Shaft Wear Inspection

- Visually inspect the area on the rocker arm where the cam rubs.
- ★ If there is any damage or uneven wear, replace the rocker arm.
- Measure the inside diameter [A] of each rocker arm.

##### Rocker Arm Inside Diameter

Standard: 10.000 ~ 10.015 mm (0.39370 ~ 0.39429 in.)

Service Limit: 10.05 mm (0.3957 in.)

- ★ If it exceeds the service limit, replace the rocker arm.
- Measure the outside diameter [B] of each rocker shaft where the rocker arm fits.

##### Rocker Shaft Outside Diameter

Standard: 9.980 ~ 9.995 mm (0.3929 ~ 0.3935 in.)

Service Limit: 9.95 mm (0.392 in.)

- ★ If the diameter falls below the service limit, replace the rocker shaft.

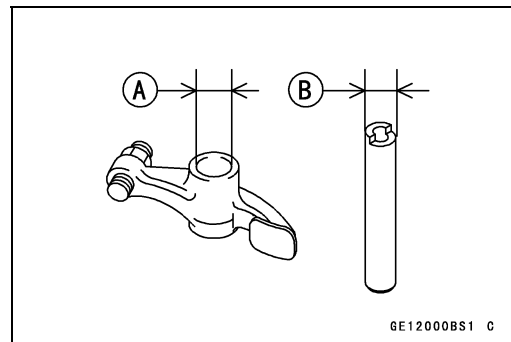
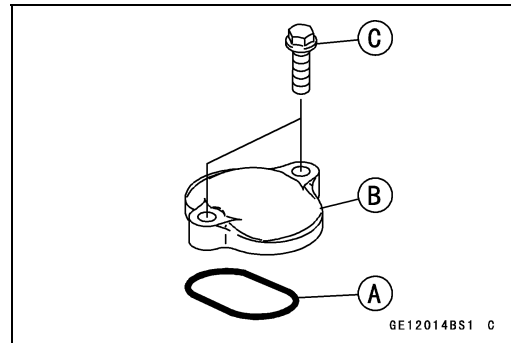

## Cylinder Head

### Cylinder Compression Measurement

#### NOTE

○Use the battery which is fully charged.

- Warm up the engine thoroughly.
- Stop the engine.
- Remove:
  - Spark Plug (see Spark Plug Replacement in the Periodic Maintenance chapter)
- Attach the compression gauge [A] and adapter [B] firmly into the spark plug hole.
- Using the starter motor, turn the engine over with the throttle fully open until the compression gauge stops rising; the compression is the highest reading obtainable.

**Special Tools - Compression Gauge, 20 kgf/cm<sup>2</sup>: 57001-221**  
**Compression Gauge Adapter, M10 × 1.0: 57001-1486**

#### Cylinder Compression

**Usable Range: 294 ~ 518 kPa (3.0 ~ 5.3 kgf/cm<sup>2</sup>, 43 ~ 75 psi) @400 r/min (rpm)**

- Install the spark plug (see Spark Plug Replacement in the Periodic Maintenance chapter).

○The following table should be consulted if the obtainable compression reading is not within the usable range.

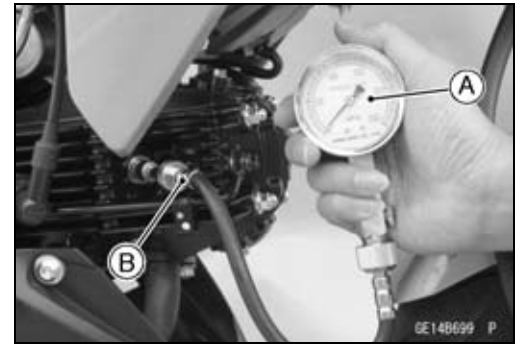

Problem	Diagnosis	Remedy (Action)
Cylinder compression is higher than usable range.	Carbon accumulation on piston and in combustion chamber possibly due to damaged valve stem oil seal and/or damaged piston oil rings (This may be indicated by white exhaust smoke).	Remove the carbon deposits and replace damaged parts if necessary.
	Incorrect cylinder head gasket thickness	Replace the gasket with a standard part.
Cylinder compression is lower than usable range.	Gas leakage around cylinder head	Replace damaged gasket and check cylinder head warp.
	Bad condition of valve seating	Repair if necessary.
	Incorrect valve clearance	Adjust the valve clearance.
	Incorrect piston/cylinder clearance	Replace the piston and/or cylinder.
	Piston seizure	Inspect the cylinder and replace/repair the cylinder and/or piston as necessary.
	Bad condition of piston ring and/or piston ring grooves	Replace the piston and/or the piston rings.

## 4-22 ENGINE TOP END

### Cylinder Head

#### Cylinder Head Removal

- Remove:
  - Camshaft Sprocket (see Camshaft Sprocket Removal)
  - Muffler (see Muffler Removal)
  - Oil Pipe (see Oil Pipe Removal in the Engine Lubrication System chapter)
- Disconnect:
  - Spark Plug Cap [A]

#### NOTICE

**When removing the spark plug cap, do not pull the lead. The lead could be broken off or damaged the wires inside.**

- Remove:
  - Intake Pipe Bolts [B] and washers.
- Remove the cylinder head bolts [A] first, then remove the nuts [B], washer and cylinder head.

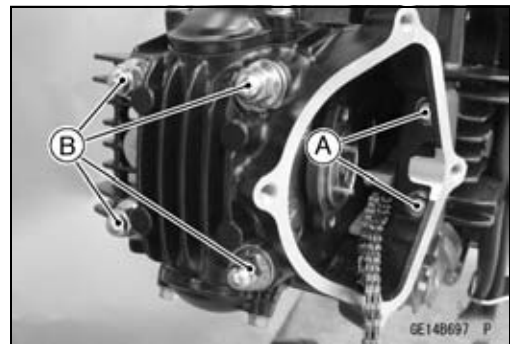
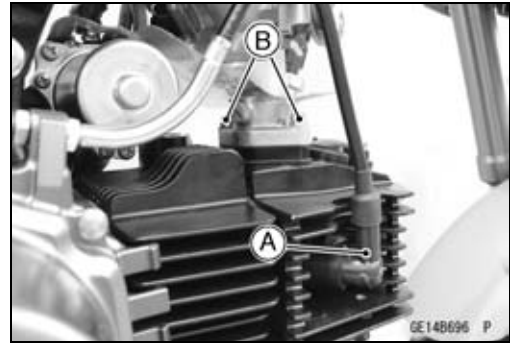

#### Cylinder Head Installation

- Check to see that the two dowel pins [A] are in place on the cylinder.
- Install a new cylinder head gasket [B].

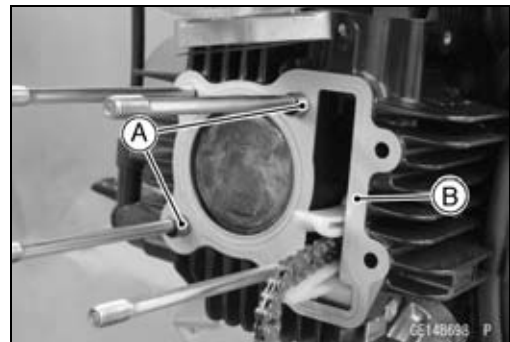

- Fit the cylinder head onto the cylinder block using a suitable tool or wire to keep the chain from falling down into the cylinder block.
- Replace the washer on the cylinder head nut [2] with a new one.
- Apply a non-permanent locking agent to the cylinder head bolts [5] [6].
- Tighten the cylinder head nuts and bolts following the tightening sequence [1 ~ 6].

**Torque - Cylinder Head Bolts: 12 N·m (1.2 kgf·m, 106 in·lb)**  
**Cylinder Head Nuts: 22 N·m (2.2 kgf·m, 16 ft·lb)**

- Install the removed parts (see appropriate chapters).

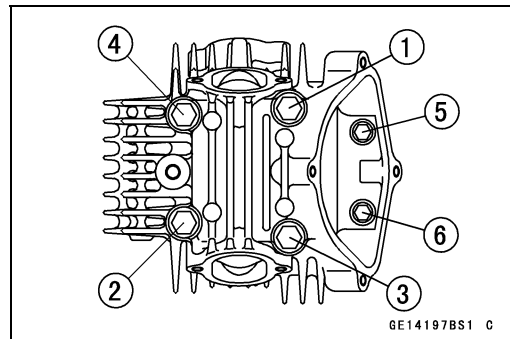

## Cylinder Head

### **Cylinder Head Cleaning**

- Scrape out any carbon, and wash the head with high flash-point solvent.

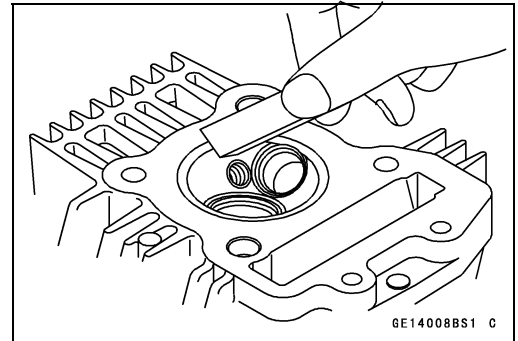

### **Cylinder Head Warp Inspection**

- Lay a straightedge across the lower surface of the cylinder head at several positions.
- Use a thickness gauge [A] to measure the space between the straightedge [B] and the cylinder head.

#### **Cylinder Head Warp**

**Service Limit: 0.03 mm (0.001 in.)**

- ★ If the cylinder head is warped more than the service limit, replace it.
- ★ If the cylinder head is warped less than the service limit, repair the head by rubbing the lower surface on emery paper secured to a surface plate (first No. 200, then No. 400).

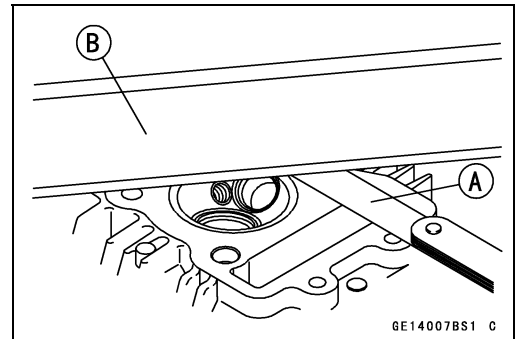

## 4-24 ENGINE TOP END

### Valves

#### Valve Clearance Inspection

- Refer to the Valve Clearance Inspection in the Periodic Maintenance chapter.

#### Valve Clearance Adjustment

- Refer to the Valve Clearance Adjustment in the Periodic Maintenance chapter.

#### Valve Removal

- Remove:
  - Cylinder Head (see Cylinder Head Removal)
  - Rocker Arms and Rocker Shafts (see Rocker Arm Removal)
  - Camshaft (see Camshaft Removal)
- Using the valve spring compressor assembly [A] and valve spring compressor adapter [B], remove the valve.

**Special Tools - Valve Spring Compressor Assembly: 57001-241**

**Valve Spring Compressor Adapter,  $\phi 20$ : 57001-1154**

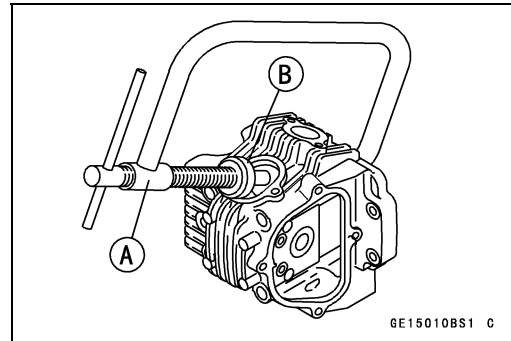

#### Valve Installation

- Replace the valve stem oil seal [A] with a new one.
- ★ If a new valve is to be used, check the valve to guide clearance.
- ★ If there is too much clearance, install a new valve guide.
- Check the spring seat [B].
- Apply engine oil to the valve stem oil seal lip.
- Push a new valve stem oil seal into place.
- Apply thin coat of molybdenum disulfide grease to the valve stem [C].
- Install the spring [D] so that the closed coil end [E] faces downwards, red or white paint faces upward.
- Install the red painted valve spring to the exhaust valve.
- Install the white painted valve spring to the intake valve.
- Install the spring retainer [F] press it down with the valve spring compressor assembly, and put on the split keepers [G].

**Special Tools - Valve Spring Compressor Assembly: 57001-241**

**Valve Spring Compressor Adapter,  $\phi 20$ : 57001-1154**

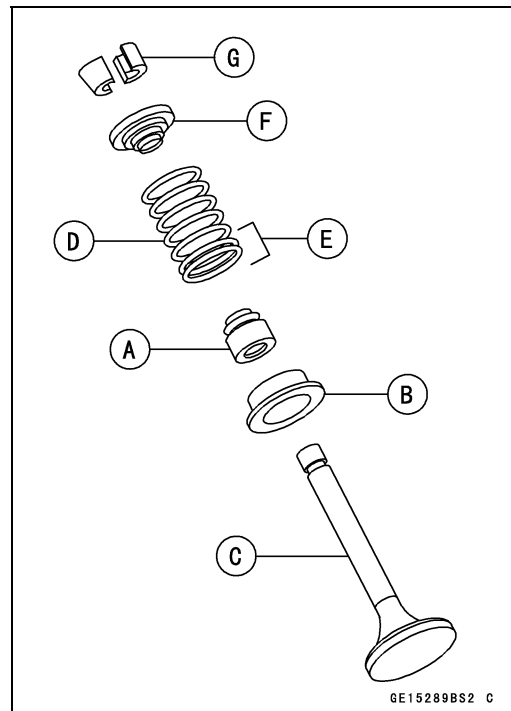

- After making sure that the split keepers and valve stem are all properly fitted, remove the tools.
- Install the removed parts (see appropriate chapters).
- Check the valve clearance, and adjust it if necessary (see Valve Clearance Inspection in the Periodic Maintenance chapter).

## Valves

### Valve Guide Removal

- Remove:
  - Cylinder Head (see Cylinder Head Removal)
  - Valve (see Valve Removal)
- Heat the area around the valve guide to about 120 ~ 150°C (248 ~ 302°F).

#### NOTICE

**Do not heat the cylinder head with a torch. This will warp the cylinder head. Soak the cylinder head and heat the oil.**

- Hammer lightly on the valve guide arbor [A] to remove the guide from top of the head.  
**Special Tool - Valve Guide Arbor,  $\phi$ 4.5: 57001-1331**

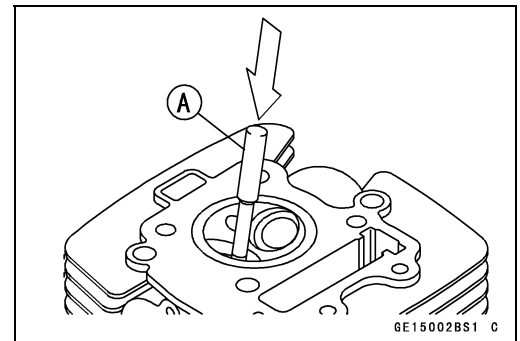

### Valve Guide Installation

#### NOTE

○ Valve guides are identical.

- Apply engine oil to the valve guide outer surface before installation.
- Heat the area around the valve guide hole to about 120 ~ 150°C (248 ~ 302°F).

#### NOTICE

**Do not heat the cylinder head with a torch. This will warp the cylinder head. Soak the cylinder head and heat the oil.**

- Using the valve guide arbor [A], drive the valve guide [B] in until its new snap ring [C] comes in contact with the head surface.  
**Special Tool - Valve Guide Arbor,  $\phi$ 4.5: 57001-1331**
- Allow the cylinder head to cool.

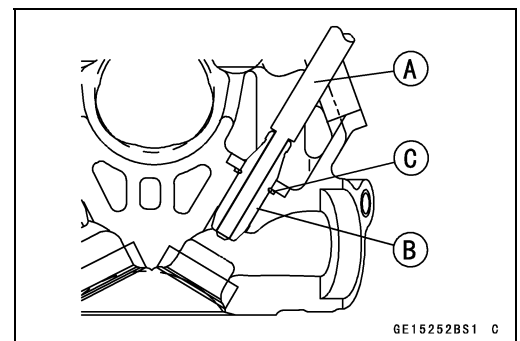

## 4-26 ENGINE TOP END

### Valves

- Ream the valve guide with the valve guide reamer [A] even if the old guide is reused.

Special Tool - Valve Guide Reamer,  $\phi 4.5$ : 57001-1333

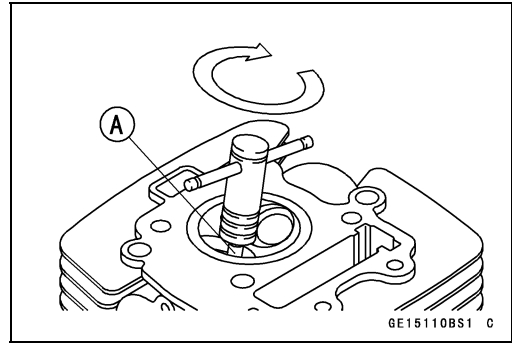

### Valve-to-Guide Clearance Measurement (Wobble Method)

If a small bore gauge is not available, inspect the valve guide wear by measuring the valve to valve guide clearance with the wobble method as follows.

- Insert a new valve [A] into the valve guide [B] and set a dial gauge against the stem perpendicular to it as close as possible to the cylinder head mating surface.
- Move the stem back and forth [C] to measure valve/valve guide clearance.

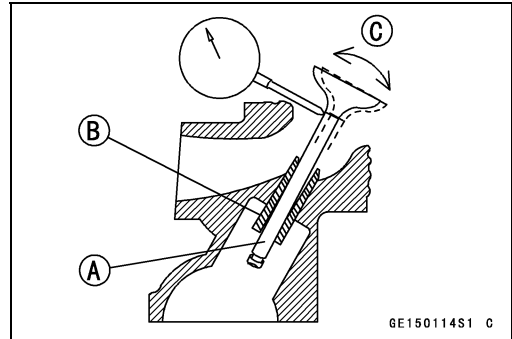

### Valve/Valve Guide Clearance (Wobble Method)

#### Standard:

Exhaust 0.06 ~ 0.11 mm (0.0024 ~ 0.0043 in.)

Intake 0.02 ~ 0.08 mm (0.0008 ~ 0.0031 in.)

#### Service Limit:

Exhaust 0.25 mm (0.0098 in.)

Intake 0.22 mm (0.0087 in.)

- Repeat the measurement in a direction at a right angle to the first.
- ★ If the reading exceeds the service limit, replace the guide.

### NOTE

- The reading is not actual valve/valve guide clearance because the measuring point is above the guide.



## Valves

### Valve Seat Inspection

- Remove the valve (see Valve Removal).
- Check the valve seat surface [A] between the valve [B] and valve seat [C].
- Coat the valve seat with machinist's dye.
- Push the valve into the guide.
- Rotate the valve against the seat with a lapping tool.
- Pull the valve out, and check the seating pattern on the valve head. It must be the correct width and even all the way around.
- Measure the outside diameter [D] of the seating pattern on the valve seat.
- ★ If the outside diameter is too large or too small, repair the seat (see Valve Seat Repair).

#### Valve Seat Surface Outside Diameter

##### Standard:

Exhaust	19.9 ~ 20.1 mm (0.783 ~ 0.791 in.)
Intake	22.9 ~ 23.1 mm (0.902 ~ 0.909 in.)

### NOTE

○ The valve stem and guide must be in good condition or this check will not be valid.

- ★ If the valve seating pattern is not correct, repair the seat.
- Measure the seat width [E] of the portion where there is no build-up carbon (white portion) of the valve seat with a vernier caliper.
- Good [F]
- ★ If the width is too wide [G], too narrow [H] or uneven [J], repair the seat (see Valve Seat Repair).

#### Valve Seat Width

##### Standard:

Exhaust	0.80 ~ 1.15 mm (0.031 ~ 0.045 in.)
Intake	0.80 ~ 1.15 mm (0.031 ~ 0.045 in.)

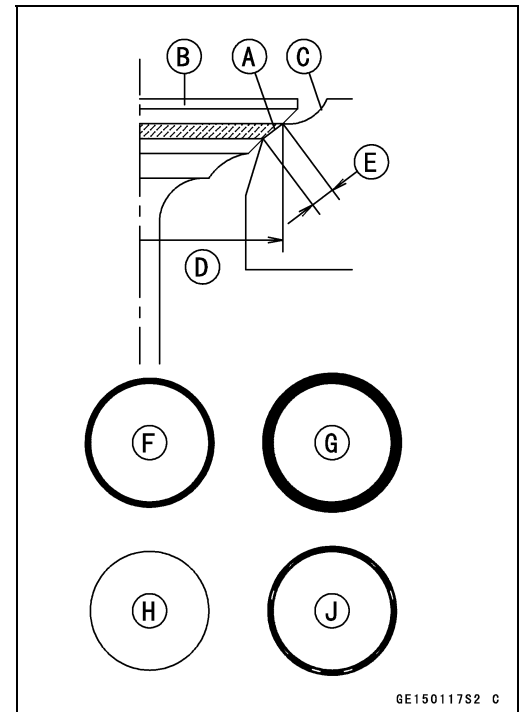

GE150117S2 C

# 4-28 ENGINE TOP END

## Valves

### Valve Seat Repair

- Repair the valve seat with the valve seat cutters.

Special Tools - Valve Seat Cutter Holder Bar: 57001-1128  
Valve Seat Cutter Holder,  $\phi 4.5$ : 57001-1330

### Exhaust

Special Tools - Valve Seat Cutter, 45° -  $\phi 22$ : 57001-1205  
Valve Seat Cutter, 32° -  $\phi 22$ : 57001-1206  
Valve Seat Cutter, 67.5° -  $\phi 22$ : 57001-1207

### Intake

Special Tools - Valve Seat Cutter, 45° -  $\phi 27.5$ : 57001-1114  
Valve Seat Cutter, 32° -  $\phi 25$ : 57001-1118  
Valve Seat Cutter, 60° -  $\phi 30$ : 57001-1123

★If the manufacturer's instructions are not available, use the following procedure.

### Seat Cutter Operating Care

1. This valve seat cutter is developed to grind the valve for repair. Therefore the cutter must not be used for other purpose than seat repair.
2. Do not drop or shock the valve seat cutter, or the diamond particles may fall off.
3. Do not fail to apply engine oil to the valve seat cutter before grinding the seat surface. Also wash off ground particles sticking to the cutter with washing oil.

#### NOTE

○Do not use a wire brush to remove the metal particles from the cutter. It will take off the diamond particles.

4. Setting the valve seat cutter holder in position, operate the cutter in one hand. Do not apply too much force to the diamond position.

#### NOTE

○Prior to grinding, apply engine oil to the cutter and during the operation, wash off any ground particles sticking to the cutter with washing oil.

5. After use, wash the cutter with washing oil and apply a thin layer of engine oil before storing.

### Marks Stamped on the cutter

The marks stamped on the back of the cutter [A] represent the following.

- 60° ..... Cutter angle [B]  
30 $\phi$  ..... Outer diameter of cutter [C]

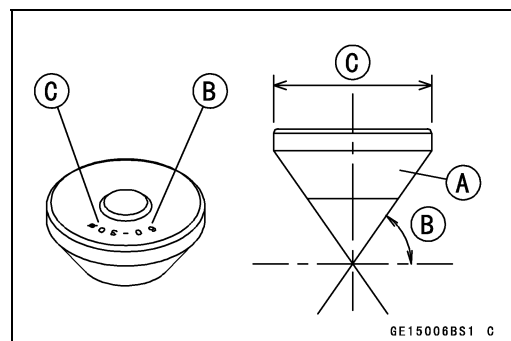

## Valves

### Operating Procedures

- Clean the seat area carefully.
- Coat the seat with machinist's dye.
- Fit a 45° cutter [A] to the holder [B] and slide it into the valve guide.
- Press down lightly on the handle [C] and turn it right or left. Grind the seating surface only until it is smooth.

### NOTICE

**Do not grind the seat too much. Overgrinding will reduce valve clearance by sinking the valve into the head. If the valve sinks too far into the head, it will be impossible to adjust the clearance, and the cylinder head must be replaced.**

- Valve seat area form is as follows:  
Widened Width [A] of engagement by machining with 45° cutter  
Ground Volume [B] by 32° cutter  
32° [C]  
Correct Width [D]  
Ground Volume [E] by 60° or 67.5° cutter  
60° or 67.5° [F]

- Measure the outside diameter of the seating surface with a vernier caliper.
- ★ If the outside diameter of the seating surface is too small, repeat the 45° [A] grind until the diameter is within the specified range.  
Original Seating Surface [B]

### NOTE

- Remove all pittings of flaws from 45° ground surface.
- After grinding with 45° cutter, apply thin coat of machinist's dye to seating surface. This makes seating surface distinct and 32° and 60° or 67.5° grinding operation easier.
- When the valve guide is replaced, be sure to grind with 45° cutter for centering and good contact.

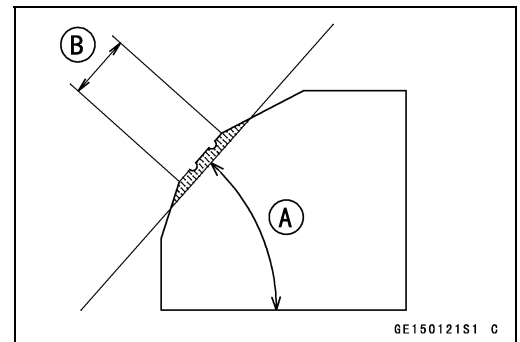
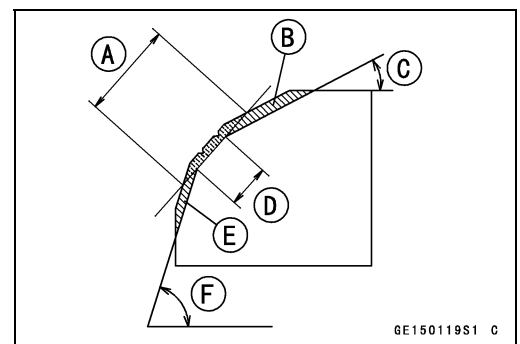
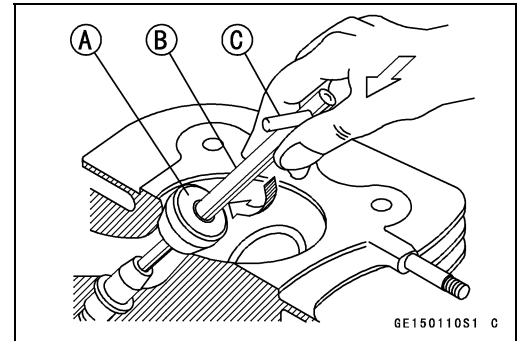

## 4-30 ENGINE TOP END

### Valves

- ★ If the outside diameter [A] of the seating surface is too large, make the 32° [B] grind described below.
- ★ If the outside diameter of the seating surface is within the specified range, measure the seat width as described below.
- Grind the seat at a 32° angle until the seat outside diameter is within the specified range.
- To make the 32° grind, fit a 32° cutter into the holder, and slide it into the valve guide.
- Turn the holder one turn at a time while pressing down very lightly. Check the seat after each turn.

#### NOTICE

**The 32° cutter removes material very quickly. Check the seat outside diameter frequently to prevent overgrinding.**

- After making the 32° grind, return to the seat outside diameter measurement step above.
- To measure the seat width, use a vernier caliper to measure the width of the 45° angle portion of the seat at several places around the seat.
- ★ If the seat width is too narrow, repeat the 45° grind until the seat is slightly too wide, and then return to the seat outside diameter measurement step above.
- ★ If the seat width is too wide, make the 60° or 67.5° [A] grind described below.
- ★ If the seat width is within the specified range, lap the valve to the seat as described below.
- Grind the seat at a 60° or 67.5° angle until the seat width is within the specified range.
- To make the 60° or 67.5° grind, fit 60° or 67.5° cutter into the holder, and slide it into the valve guide.
- Turn the holder, while pressing down lightly.
- After making the 60° or 67.5° grind, return to the seat width measurement step above.

Correct Width [B]

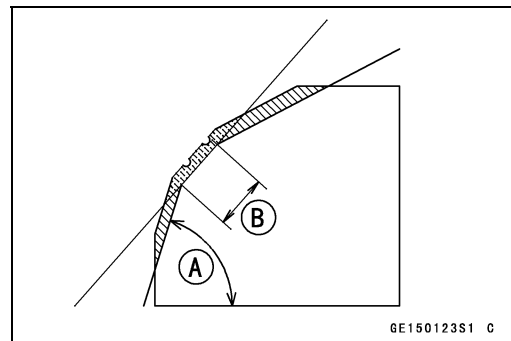
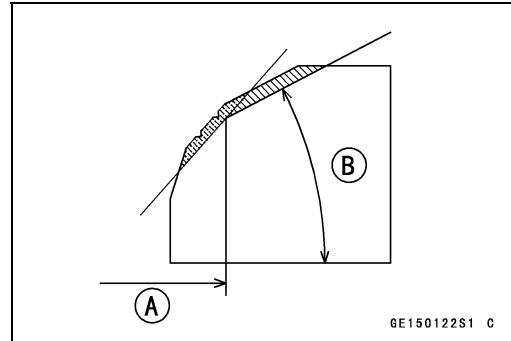

## Valves

- Lap the valve to the seat using a lapper, once the seat width and outside diameter are within the ranges specified above.
- Put a little coarse grinding compound on the face of the valve in a number of places around the valve head.
- Spin the valve against the seat until the grinding compound produces a smooth, matched surface on both the seat and the valve.
- Repeat the process with fine grinding compound.
  - Lapper [A]
  - Valve Seat [B]
  - Valve [C]
- The seating area should be marked about in the middle of the valve face.
- ★ If the seat area is incorrect place on the valve, be sure to check the valve is the correct part. If it is, it may have been refaced too much replace the valve.
- Be sure to remove all grinding compound before assembly.
- When the engine is assembled, be sure to adjust the valve clearance (see Valve Clearance Inspection in the Periodic Maintenance chapter).

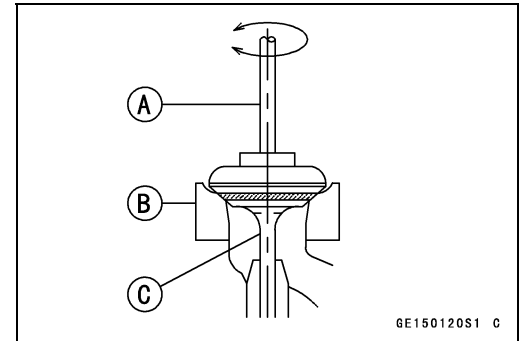

# 4-32 ENGINE TOP END

## Valves

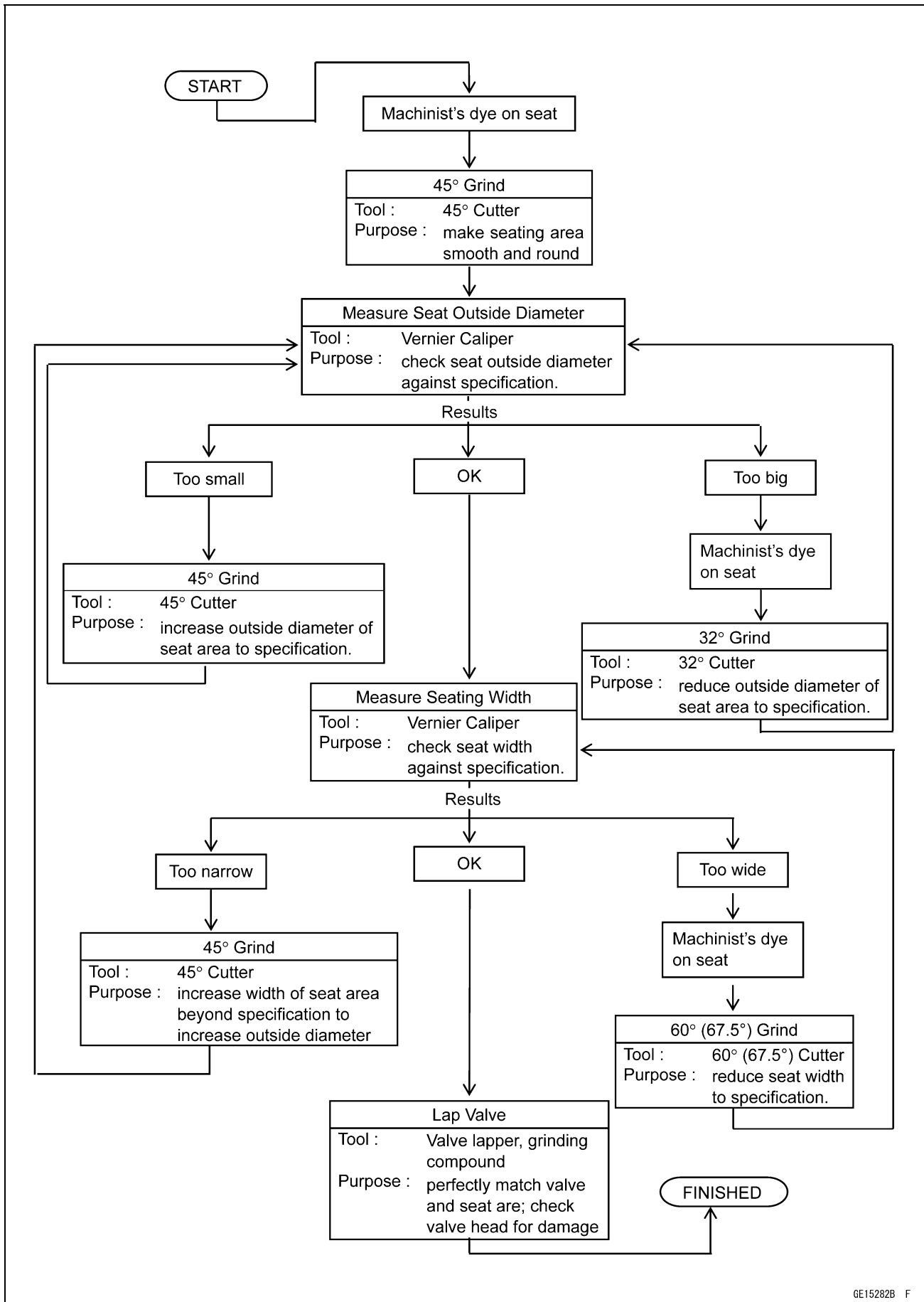

## Cylinder, Piston

### Cylinder Removal

- Remove:
  - Cylinder Head (see Cylinder Head Removal)
  - Lower Camshaft Chain Guide [A]
  - Cylinder [B]

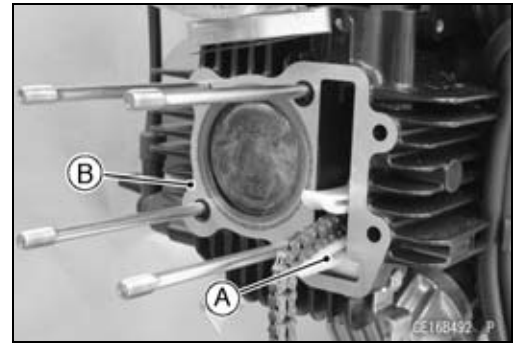

### Cylinder Installation

#### NOTE

○ If the cylinder block is replaced with a new one, piston/cylinder clearance must be checked against the specified value (see Piston/Cylinder Clearance Inspection).

- Install a new cylinder base gasket [A] and be sure that two dowel pins [B] are properly fitted in the crankcase.
- Strain the camshaft chain top avoid kinking it and use a wrench on the crankshaft to set the piston at BDC.
- Position the piston ring opening as follows.
  - Top Ring [A]
  - Second Ring [B]
  - Upper Steel Rail [C]
  - Expander [D]
  - Lower Steel Rail [E]
  - 30 ~ 90° [F]

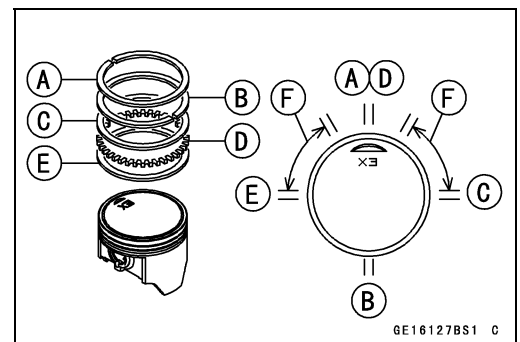
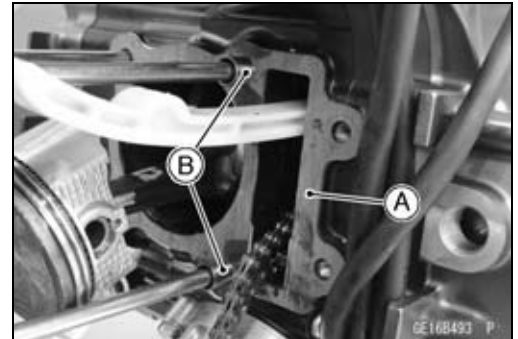

- Apply engine oil to the piston rings and the cylinder inside surface.
- Pull the camshaft chain up through the cylinder and insert a suitable tool to keep the chain from falling back into the engine.
- Place the upper camshaft chain guide inside the cylinder block.
- Fit the bottom of the cylinder over the piston rings, pressing in on opposite sides of the rings as necessary. Take care that the rings do not slip out of their proper positions.
- Insert the lower camshaft chain guide [A] securely.



# 4-34 ENGINE TOP END

## Cylinder, Piston

### Piston Removal

- Remove the cylinder (see Cylinder Removal).
- Wrap a clean cloth around the base of the piston.
- Using the pliers [A] and remove the snap ring [B].

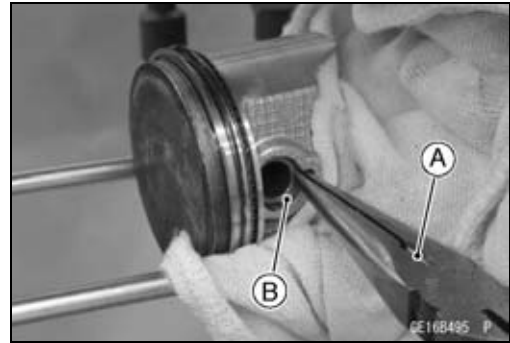

- Remove the piston by pushing its pin pull out the side that the snap ring was removed. Use the piston pin puller assembly [A] if the pin is tight.

**Special Tool - Piston Pin Puller Assembly: 57001-910**

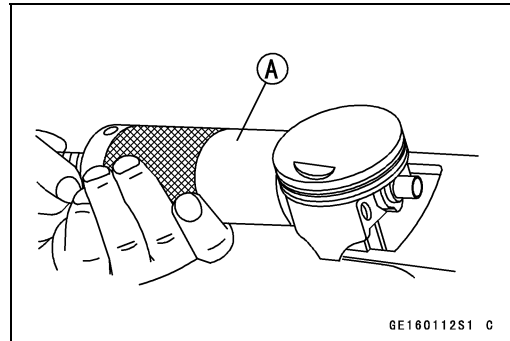

- Remove the piston rings [A].
- Carefully spread the ring opening with your thumbs and then push up on the opposite side of the ring to remove it.

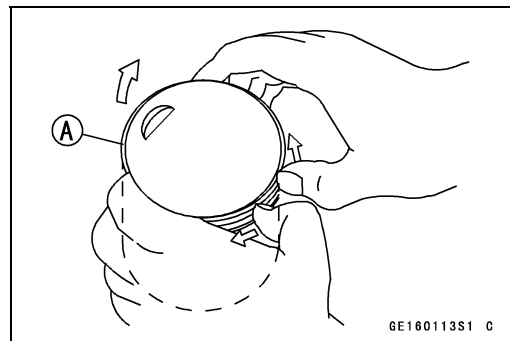

### Piston Installation

#### NOTE

○ The oil ring steel rails have no "top" or "bottom."

- Install the oil ring expander [A] in the bottom piston ring groove so that the ends [B] but together, never overlap.
- Install the oil ring steel rails, one above the expander and one below it.
- Spread the rail with your thumbs, but only enough to fit the rail over the piston.
- Release the rail into the bottom piston ring groove.
- Do not mix up the top ring and second ring.
- Install the top ring [A] so that the "R" mark [B] faces up.
- Install the second ring [C] so that the "RN" mark [D] faces up.

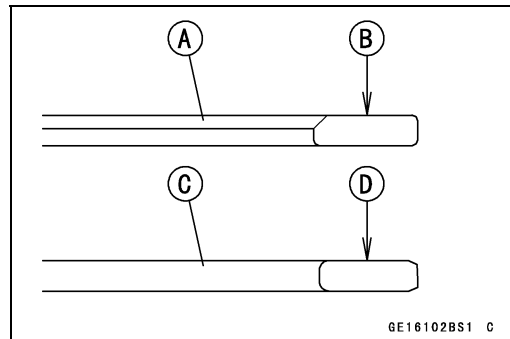
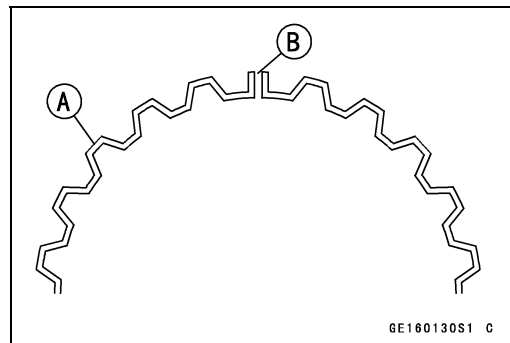



**Cylinder, Piston**

**NOTE**

○If a new piston is used, check piston/cylinder clearance (see *Piston/Cylinder Clearance Inspection*), and use new piston rings.

- Install the piston so that the “EX” mark [A] on the piston faces toward exhaust side.
- Apply engine oil to the piston pin and the piston pin hole.
- Install the piston pin.

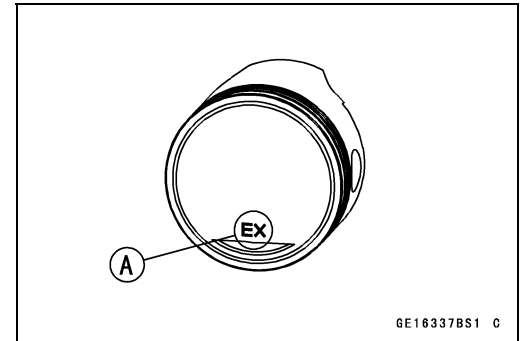

- Wrap a clean cloth around the base of the piston.
- Fit a new piston pin snap ring into the side of the piston so that the ring opening [A] does not coincide with the slit [B] of the piston pin hole.
- When installing a piston pin snap ring, compress it only enough to install it no more.

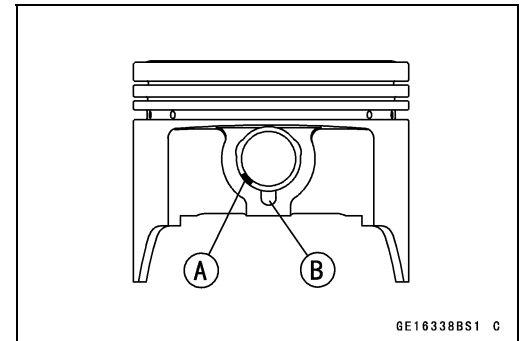

**NOTICE**

**Do not reuse snap rings, as removal weakens and deforms them. They could fall out and score the cylinder wall.**

- Install the cylinder (see *Cylinder Installation*).

**Cylinder Wear Inspection**

- Since there is a difference in cylinder wear in different directions, take a side to side and a front to back measurement at each of the 3 locations (total of 6 measurements) shown.
- ★ Other than ID model, if any of the cylinder inside diameter measurements exceeds the service limit, replace the cylinder.
- ★ For ID model, if any of the cylinder inside diameter measurements exceeds the service limit, the cylinder will have to be bored to oversize and then honed.

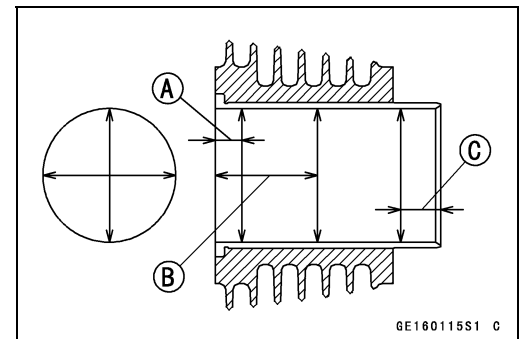

**Cylinder Inside Diameter**

**Standard:** 55.986 ~ 55.998 mm (2.2042 ~ 2.2046 in.) and less than 0.01 mm (0.0004 in.) difference between any two measurements

**Service Limit:** 56.09 mm (2.208 in.) or 0.05 mm (0.002 in.) difference between any two measurements

10 mm (0.39 in.) [A]

60 mm (2.4 in.) [B]

20 mm (0.79 in.) [C]

## 4-36 ENGINE TOP END

### Cylinder, Piston

#### **Piston Wear Inspection**

- Measure the outside diameter [A] of the piston **5 mm (0.2 in.)** [B] up from the bottom of the piston at a right angle to the direction of the piston pin.

#### **Piston Diameter**

**Standard:** 55.970 ~ 55.982 mm (2.2035 ~ 2.2040 in.)

**Service Limit:** 55.82 mm (2.198 in.)

#### **NOTE**

○ *Abnormal wear such as a marked diagonal pattern across the piston skirt may mean a bent connecting rod or crankshaft.*

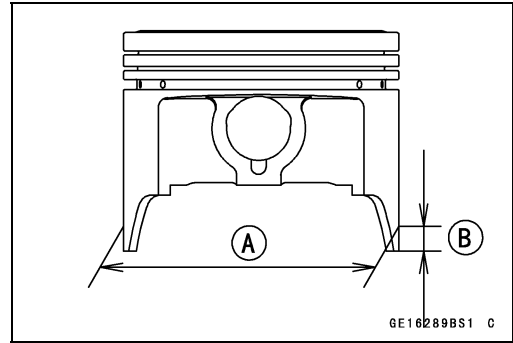

#### **Piston/Cylinder Clearance Inspection**

The most accurate way to find the piston clearance is by making separate piston and cylinder diameter measurements and then computing the difference between the two values. Measure the piston diameter as just described, and measure the cylinder diameter at the very bottom of the cylinder.

#### **Piston/Cylinder Clearance**

**Standard:** 0.011 ~ 0.023 mm (0.00043 ~ 0.00091 in.)

#### **NOTE**

○ *Whenever the piston cylinder has been replaced with a new one, the motorcycle must be broken in the same as with a new machine.*

#### **Piston Ring, Piston Ring Groove Wear Inspection**

- Check for uneven groove wear by inspecting the ring seating.
- ★ The rings should fit perfectly parallel to groove surfaces. If not, replace the piston and all the piston rings.
- With the piston rings in their grooves, make several measurements with a thickness gauge [A] to determine piston ring/groove clearance.

#### **Piston Ring/Groove Clearance**

#### **Standard:**

**Top** 0.02 ~ 0.06 mm (0.0008 ~ 0.0024 in.)

**Second** 0.01 ~ 0.05 mm (0.0004 ~ 0.0020 in.)

#### **Service Limit:**

**Top** 0.16 mm (0.0063 in.)

**Second** 0.15 mm (0.0059 in.)

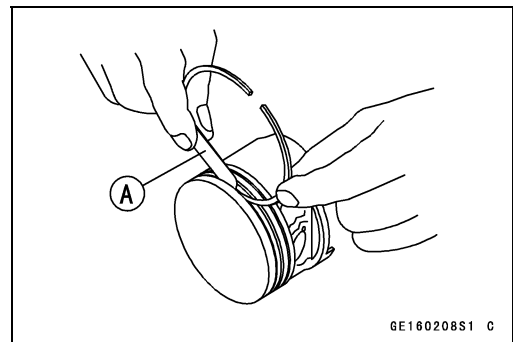

**Cylinder, Piston**

**Piston Ring Groove Width Inspection**

- Measure the piston ring groove width.
- Use a vernier caliper at several points around the piston.

**Piston Ring Groove Width**

**Standard:**

Top [A]      0.81 ~ 0.83 mm (0.0319 ~ 0.0327 in.)

Second [B]   0.80 ~ 0.82 mm (0.0315 ~ 0.0323 in.)

**Service Limit:**

Top            0.91 mm (0.036 in.)

Second       0.90 mm (0.035 in.)

- ★ If the width of any of the two grooves is wider than the service limit at any point, replace the piston.

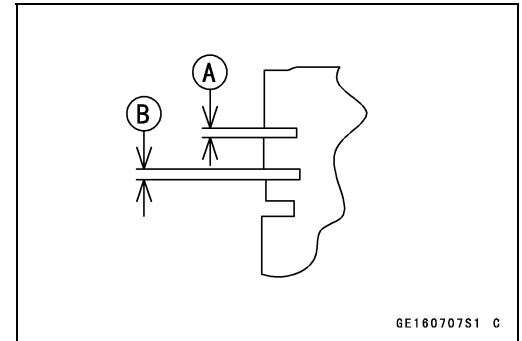

**Piston Ring Thickness Inspection**

- Measure the piston ring thickness.
- Use the micrometer to measure at several points around the ring.

**Piston Ring Thickness**

**Standard:**

Top [A]      0.77 ~ 0.79 mm (0.0303 ~ 0.0311 in.)

Second [B]   0.77 ~ 0.79 mm (0.0303 ~ 0.0311 in.)

**Service Limit:**

Top            0.70 mm (0.028 in.)

Second       0.70 mm (0.028 in.)

- ★ If any of the measurements is less than the service limit on either of the rings, replace all the rings.

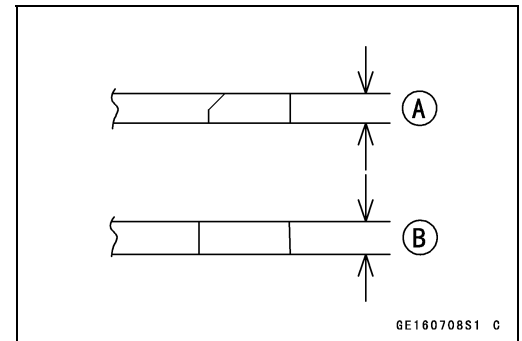

**NOTE**

- When using new rings in a used piston, check for uneven groove wear. The rings should fit perfectly parallel to the groove sides. If not, replace the piston.

**Piston Ring End Gap Inspection**

- Place the piston ring [A] inside the cylinder, using the piston to locate the ring squarely in place. Set it close to the bottom of the cylinder, where cylinder wear is low.
- Measure the gap [B] between the ends of the ring with a thickness gauge.

**Piston Ring End Gap**

**Standard:**

Top            0.15 ~ 0.30 mm (0.0059 ~ 0.0118 in.)

Second       0.30 ~ 0.45 mm (0.0118 ~ 0.0177 in.)

**Service Limit:**

Top            0.6 mm (0.02 in.)

Second       0.8 mm (0.03 in.)

- ★ If the end gap of either ring is greater than the service limit, replace all the rings.

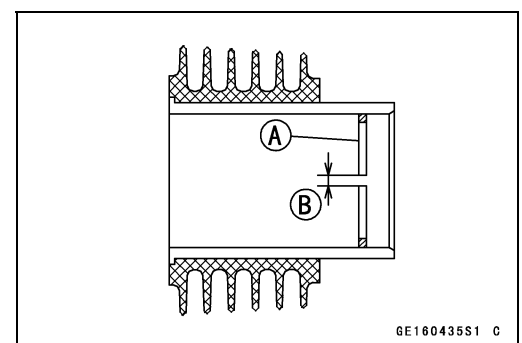

## 4-38 ENGINE TOP END

### Cylinder, Piston

#### **Piston, Piston Pin, Connecting Rod Wear Inspection**

- Visually inspect the snap rings [A] are fitted in place.
- ★ If the ring shows weakness or deformation, replace the ring. Also if the pin hole groove shows excessive wear, replace the piston.
- Visually inspect the piston pin hole and connecting rod small end hole.
- ★ If the piston pin hole shows uneven wear, replace the piston.
- ★ If the rod small end hole shows uneven wear, replace the rod, or crankshaft assembly.
- Visually inspect the outer surface of the piston pin [B].
- ★ If the pin shows color change or stepped wear, replace the pin.

- Measure the inside diameter [A] of both piston pin holes in the piston.

#### **Piston Pin Hole Diameter**

**Standard:** 13.001 ~ 13.007 mm (0.51185 ~ 0.51209 in.)

**Service Limit:** 13.08 mm (0.5150 in.)

- ★ If either piston pin hole diameter exceeds the service limit, replace the piston.
- Measure the diameter [B] of the piston pin.

#### **Piston Pin Diameter**

**Standard:** 12.995 ~ 13.000 mm (0.51161 ~ 0.51181 in.)

**Service Limit:** 12.96 mm (0.5102 in.)

- ★ If the piston pin diameter is less than the service limit at any point, replace the piston pin.
- ★ Measure the inside diameter [A] of the connecting rod small end.

#### **Connecting Rod Small End Inside Diameter**

**Standard:** 13.003 ~ 13.014 mm (0.51193 ~ 0.51236 in.)

**Service Limit:** 13.05 mm (0.5138 in.)

- ★ If the diameter exceeds the service limit, replace the connecting rod.

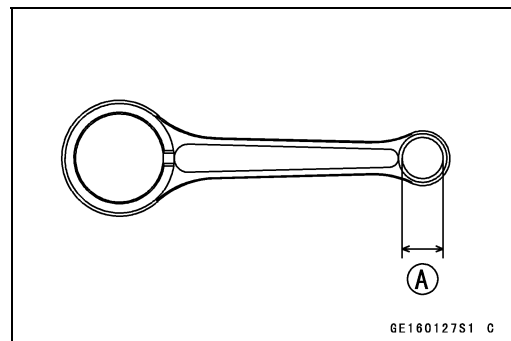
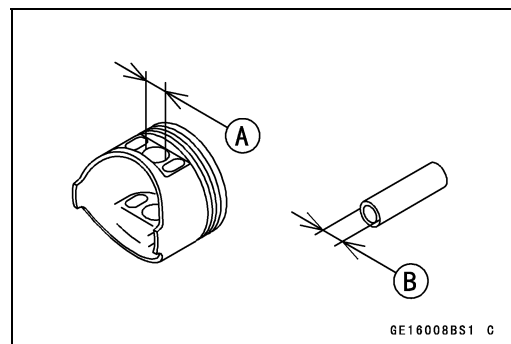
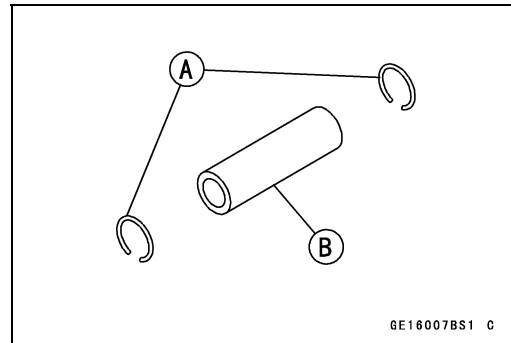

#### **Boring, Honing Performance (ID Model)**

When boring and honing a cylinder, note the following:

- There are two sizes of oversize pistons available. Oversize pistons require oversize rings.

#### **Oversize Pistons and Rings**

+0.5 mm (0.020 in.)

+1.0 mm (0.039 in.)

## Cylinder, Piston

- Before boring a cylinder [A], first measure the exact diameter of the Specifications section, oversize piston, and then, according to the standard clearance in the determine the rebore diameter. However, if the amount of boring necessary would make the inside diameter greater than 1.0 mm (0.039 in.) oversize, the cylinder block must be replaced.
- Cylinder inside diameter must not vary more than 0.01 mm (0.0004 in.) at any points.
- Be wary of measurements taken immediately after boring since the heat affects cylinder diameter.
- In the case of a rebored cylinder and oversize piston, the service limit for the cylinder is the diameter that the cylinder was bored to plus 0.1 mm (0.004 in.) and the service limit for the piston is the oversize piston original diameter minus 0.20 mm (0.0079 in.). If the exact figure for the rebored diameter is unknown, it can be roughly determined by measuring the diameter at the base of the cylinder.

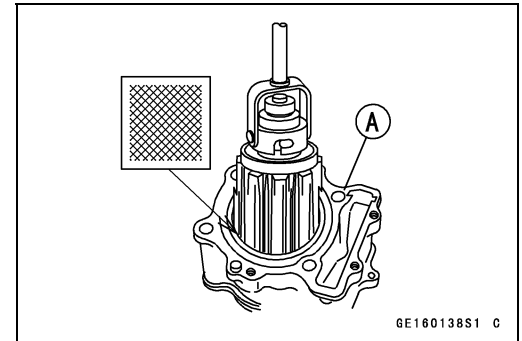

## 4-40 ENGINE TOP END

### Muffler

#### **Muffler Removal**

- Remove the oxygen sensor (see Oxygen Sensor Removal in the Electrical System chapter).
- Remove the exhaust pipe holder nuts [A].



- Remove the muffler mounting bolt [A], washers, and muffler [B].

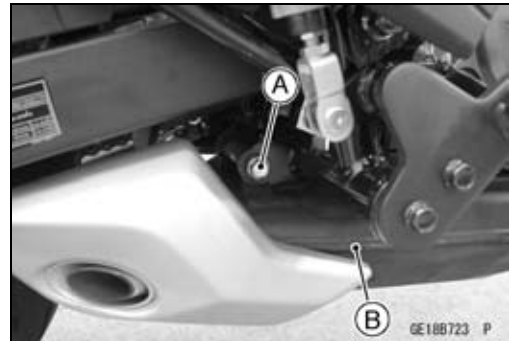

#### **Muffler Installation**

- Replace the exhaust pipe gasket with a new one.
- Install the muffler.
- Tighten the exhaust pipe holder nuts first.

**Torque - Exhaust Pipe Holder Nuts: 14.7 N·m (1.50 kgf·m, 10.8 ft·lb)**

**Muffler Body Mounting Bolt: 16.5 N·m (1.68 kgf·m, 12.2 ft·lb)**

- Thoroughly warm up the engine, wait until the engine cools down and tighten all bolt and nuts.

# Clutch

## Table of Contents

Exploded View .....	5-2
Specifications .....	5-6
Special Tools .....	5-7
Clutch Lever and Cable (BR125H/J) .....	5-8
Clutch Lever Free Play Inspection .....	5-8
Clutch Lever Free Play Adjustment .....	5-8
Clutch Cable Removal .....	5-8
Clutch Cable Installation .....	5-8
Clutch Cable Lubrication .....	5-8
Clutch Lever Holder Installation .....	5-8
Clutch Lever Installation .....	5-9
Clutch Cover .....	5-10
Clutch Cover Removal .....	5-10
Clutch Cover Installation .....	5-10
Release Shaft Removal (BR125H/J) .....	5-12
Release Shaft Installation (BR125H/J) .....	5-12
Clutch Cover Disassembly .....	5-12
Clutch Cover Assembly .....	5-13
Clutches .....	5-14
Clutch Removal (BR125G) .....	5-14
Clutch Installation (BR125G) .....	5-15
Clutch Removal (BR125H/J) .....	5-16
Clutch Installation (BR125H/J) .....	5-17
Clutch Disassembly .....	5-18
Clutch Assembly .....	5-18
Primary Clutch Housing Wear Inspection (BR125G) .....	5-19
Primary Clutch Shoe Lining Wear Inspection (BR125G) .....	5-20
One-Way Clutch Inspection (BR125G) .....	5-20
Clutch Plate Wear and Damage Inspection .....	5-21
Clutch Plate Warp Inspection .....	5-21
Clutch Housing Finger Damage Inspection .....	5-22
Clutch Hub Spline Damage Inspection .....	5-22
Clutch Spring Inspection .....	5-22

# 5-2 CLUTCH

## Exploded View

BR125G

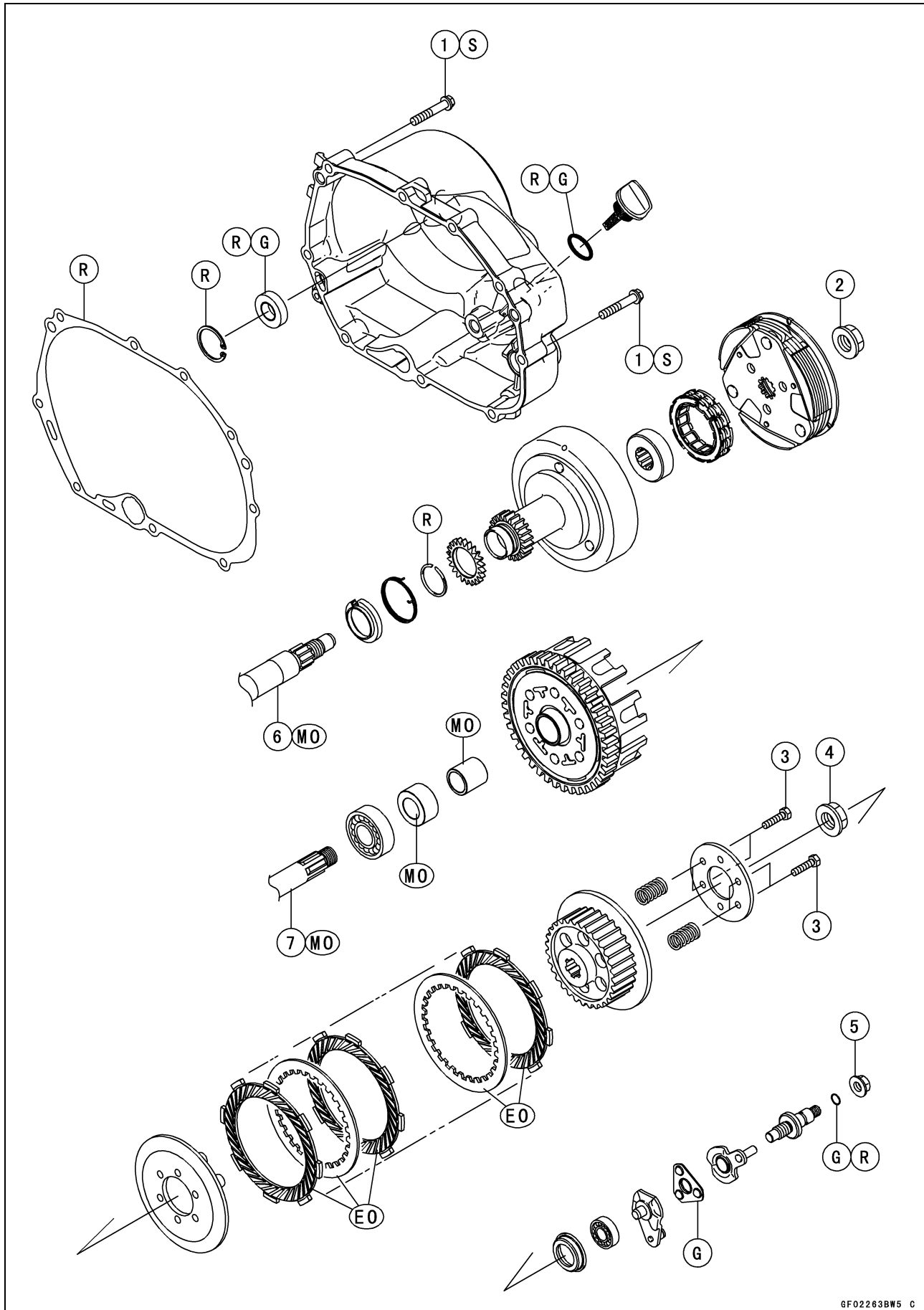



## Exploded View

No.	Fastener	Torque			Remarks
		N·m	kgf·m	ft·lb	
1	Clutch Cover Bolts	8.8	0.90	78 in·lb	S
2	Primary Clutch Hub Nut	72	7.3	53	
3	Secondary Clutch Spring Bolts	5.0	0.51	44 in·lb	
4	Secondary Clutch Hub Nut	72	7.3	53	
5	Clutch Adjusting Screw Locknut	19	1.9	14	

6. Crankshaft

7. Drive Shaft

EO: Apply engine oil.

G: Apply grease.

MO: Apply molybdenum disulfide oil solution.

(mixture of engine oil and molybdenum disulfide grease in a weight ratio 10:1)

R: Replacement Parts

S: Follow the specified tightening sequence.

# 5-4 CLUTCH

## Exploded View

BR125H/J

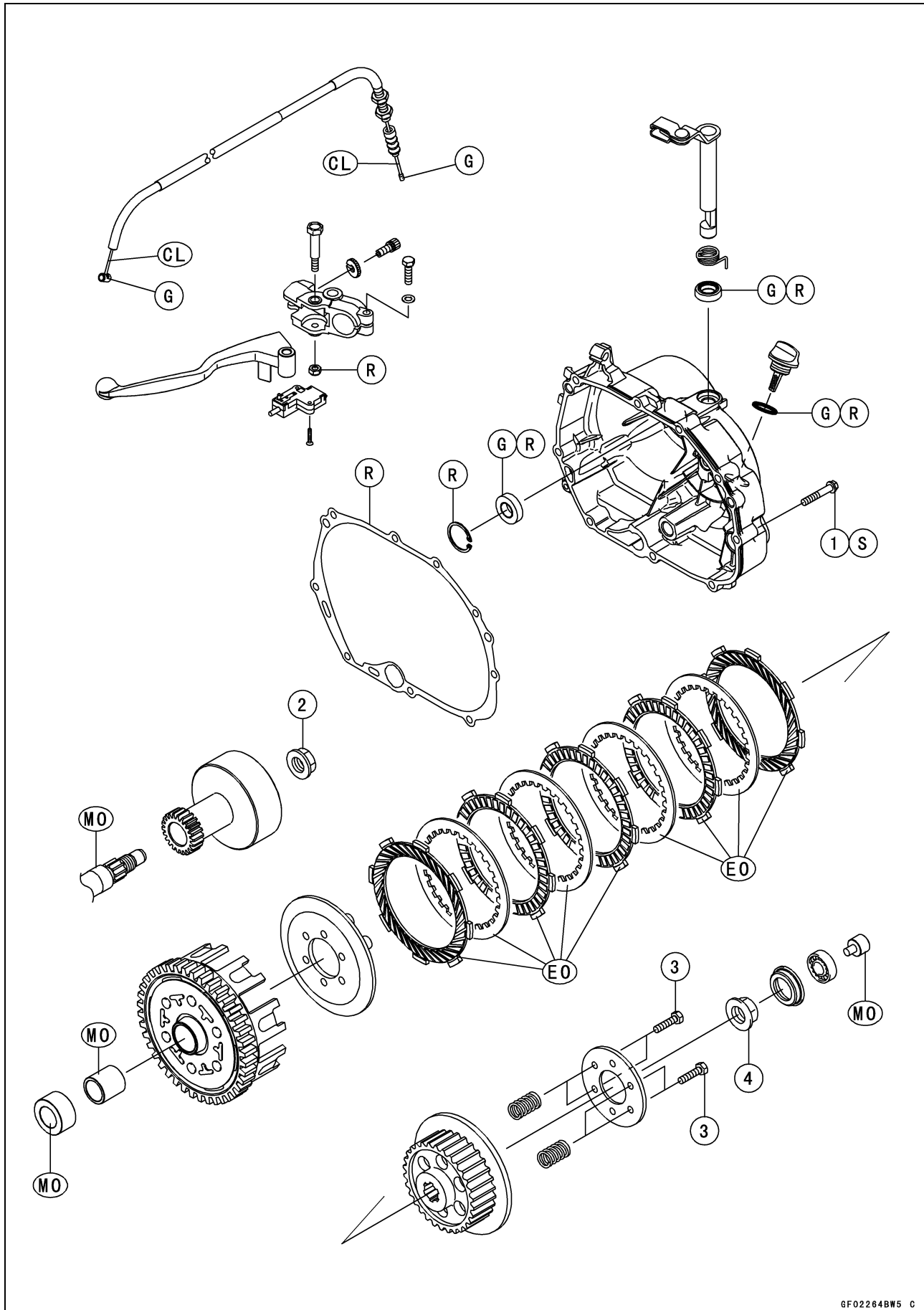

---

**Exploded View**

---

No.	Fastener	Torque			Remarks
		N·m	kgf·m	ft·lb	
1	Clutch Cover Bolts	8.8	0.90	78 in·lb	S
2	Primary Gear Nut	72	7.3	53	
3	Clutch Spring Bolts	5.0	0.51	44 in·lb	
4	Clutch Hub Nut	72	7.3	53	

CL: Apply cable lubricant.

EO: Apply engine oil.

G: Apply grease.

MO: Apply molybdenum disulfide oil solution.

(mixture of engine oil and molybdenum disulfide grease in a weight ratio 10:1)

R: Replacement Parts

S: Follow the specified tightening sequence.

## 5-6 CLUTCH

### Specifications

Item	Standard	Service Limit
<b>Clutch Lever and Cable (BR125H/J)</b>		
Clutch Lever Free Play	2 ~ 3 mm (0.08 ~ 0.12 in.)	— — —
<b>Clutches</b>		
Primary Clutch Housing Inside Diameter (BR125G)	104.0 ~ 104.2 mm (4.094 ~ 4.102 in.)	104.5 mm (4.114 in.)
Primary Clutch Shoe Groove Depth (BR125G)	1.0 mm (0.04 in.)	0.5 mm (0.02 in.)
Friction Plate Thickness:		
13088-1142 (oblique groove type plate)	3.10 ~ 3.30 mm (0.122 ~ 0.130 in.)	2.9 mm (0.11 in.)
13088-0048 (radial groove type plate)	3.12 ~ 3.28 mm (0.123 ~ 0.129 in.)	3.0 mm (0.12 in.)
Friction Plate Warp:		
13088-1142 (oblique groove type plate)	0.2 mm (0.008 in.) or less	0.3 mm (0.01 in.)
13088-0048 (radial groove type plate)	0.15 mm (0.0059 in.) or less	0.3 mm (0.01 in.)
Steel Plate Warp	0.15 mm (0.0059 in.) or less	0.3 mm (0.01 in.)
Clutch Release (BR125G)	1/4 turn out	— — —

**Special Tools**

**Inside Circlip Pliers:**  
**57001-143**

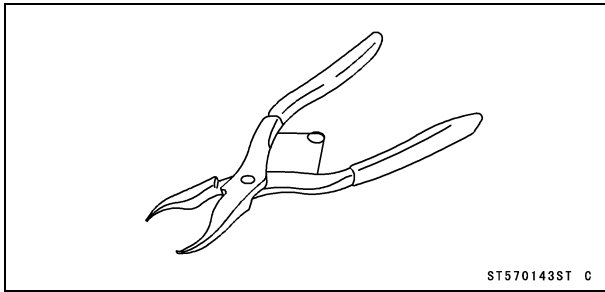

**Clutch Holder 1:**  
**57001-1507**

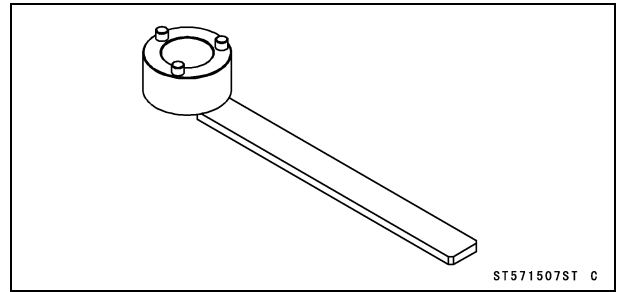

**Bearing Driver Set:**  
**57001-1129**

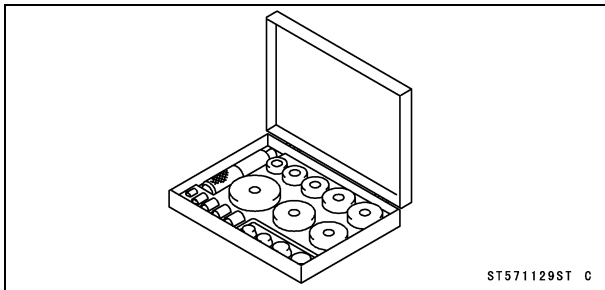

**Gear Holder:**  
**57001-1602**

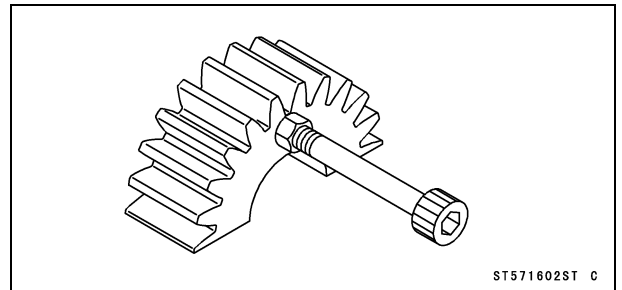

## 5-8 CLUTCH

### Clutch Lever and Cable (BR125H/J)

#### **Clutch Lever Free Play Inspection**

- Refer to the Clutch Operation Inspection in the Periodic Maintenance chapter.

#### **Clutch Lever Free Play Adjustment**

- Refer to the Clutch Operation Inspection in the Periodic Maintenance chapter.

#### **Clutch Cable Removal**

- Slide the dust cover [A] at the clutch cable lower end out of place.
- Loosen the adjusting nuts [B], and slide the lower end of the clutch cable to give the cable plenty of play.

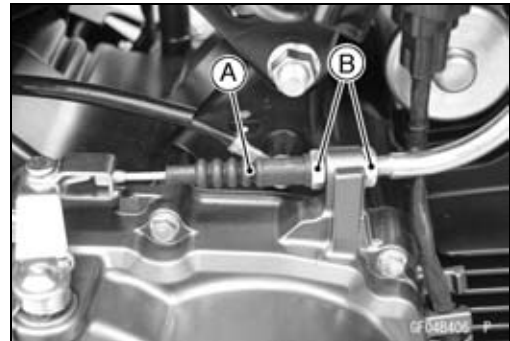

- Loosen the lock nut and screw in the adjuster [A].
- Align the slots [B] in the clutch lever, locknut and adjuster, and then free the cable from the lever.
- Free the clutch inner cable tip from the clutch release lever.
- Pull the clutch cable out of the frame.

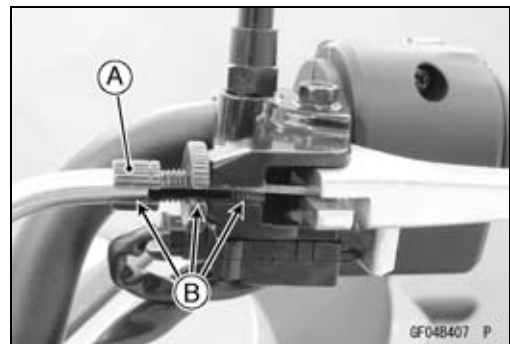

#### **Clutch Cable Installation**

- Installation is the reverse of removal.
- Run the clutch cable correctly (see Cable, Wire, and Hose Routing section in the Appendix chapter).
- Adjust the clutch cable (see Clutch Operation Inspection in the Periodic Maintenance chapter).

#### **Clutch Cable Lubrication**

- Refer to the Chassis Parts Lubrication in the Periodic Maintenance chapter.

#### **Clutch Lever Holder Installation**

- Install the clutch lever holder so that the slit [A] of the clutch lever holder clamp is aligned with the punch mark [B].
- Tighten the clutch lever holder clamp bolt [C] securely.

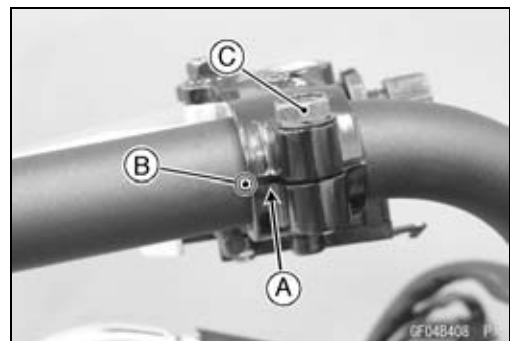

## Clutch Lever and Cable (BR125H/J)

### Clutch Lever Installation

#### **⚠ WARNING**

If the starter lockout switch pin has been damaged the starter lockout system will not work properly. This allows the motorcycle to be started in gear with the clutch lever released (clutch engaged), creating sudden forward movement that can result in an accident or injury. Check that the starter lockout switch operates properly when installing the clutch lever.

- Replace the locknut with a new one.
- Install the clutch lever [A] from frame left side [B] so that it may not damage a pin [C] of the starter lockout switch.

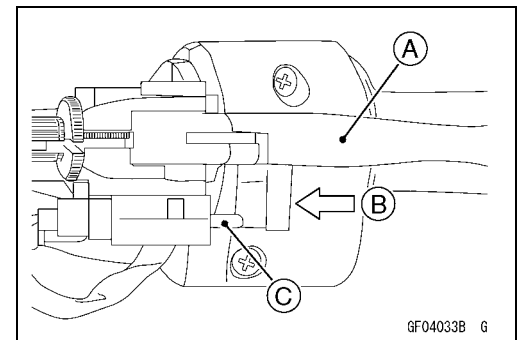

#### **NOTICE**

Do not install the clutch lever [A] from the front side [B]. The pin [C] of the starter lockout switch may be damaged in the projection [D] of a clutch lever.

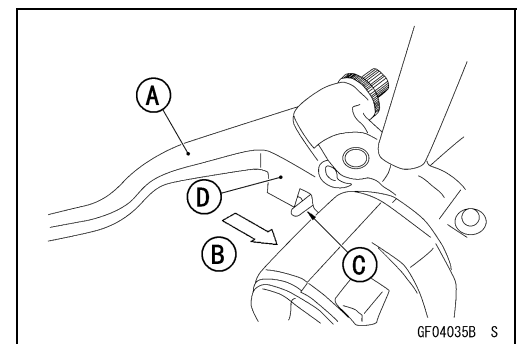

- Tighten the bolt [A] and locknut [B].
- Install the upper end of the clutch cable (see Clutch Cable Installation).
- Adjust the clutch cable (see Clutch Operation Inspection in the Periodic Maintenance chapter).
- Check that the pin [C] of the starter lockout switch moves smoothly.

#### **⚠ WARNING**

Too much cable play can prevent clutch disengagement and cause an accident resulting in serious injury or death. When adjusting the clutch or replacing the cable, be sure the upper end of the clutch outer cable is fully seated in its fitting, or it could slip into place later, creating enough cable play to prevent clutch disengagement.

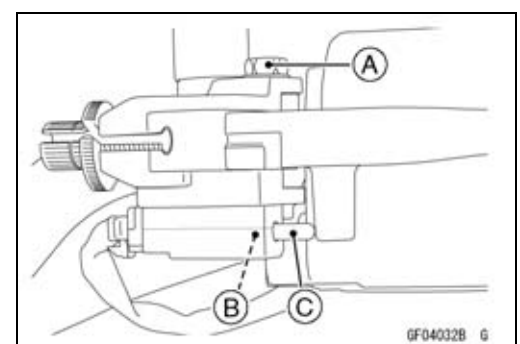

## 5-10 CLUTCH

### Clutch Cover

#### Clutch Cover Removal

- Drain the engine oil (see Engine Oil Change in the Periodic Maintenance chapter).
- For BR125H/J, remove the clutch cable lower end (see Clutch Cable Removal).
- Remove:
  - Right Side/Frame Cover (see Side/Frame Cover Removal in the Frame chapter)
  - Lower Fairing and Right Lower Fairing Bracket (see Lower Fairing Removal in the Frame chapter)
- Remove:
  - Rear Brake Light Switch Spring [A]
  - Brake Pedal Return Spring [B]
  - Right Front Footpeg Assy Bolt [C]

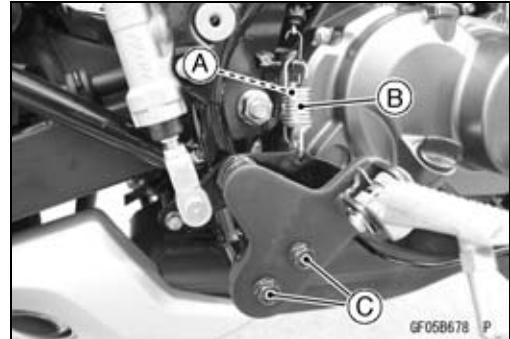

- Free the oxygen sensor lead [A] from the guides [B].
- Remove the clutch cover bolts [C] and take off the clutch cover.

#### NOTE

○For BR125G, when disassembling the clutch cover, loosen the clutch adjusting screw locknut before the clutch cover removal (see Clutch Release Adjustment in the Periodic Maintenance chapter).

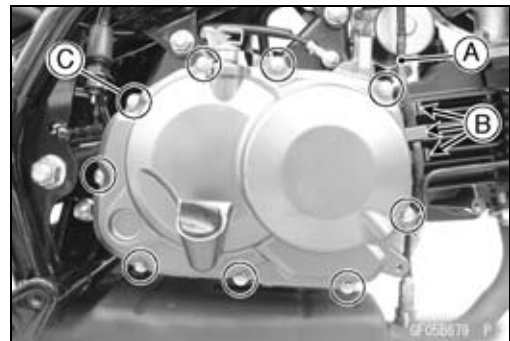

#### Clutch Cover Installation

- Assemble the clutch cover (see Clutch Cover Assembly).
- Using compressed air, blow out the oil passage [A] in the clutch cover.

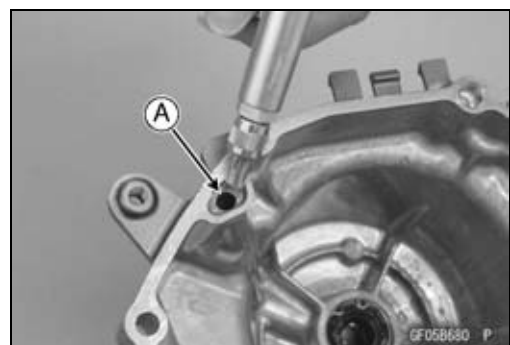



## Clutch Cover

- Check that the two dowel pins [A] are in place on the crankcase.
- Replace the clutch cover gasket [B] with a new one.
- Before install the clutch cover, be sure that the following items are in place.
  - Release Cam [C]
  - Release Ball Assembly [D]
  - Oil Screen [E]
  - Clutch Pusher [F]
  - BR125G [G]
  - BR125H/J [H]

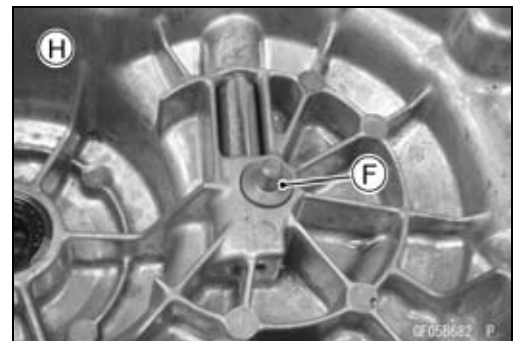
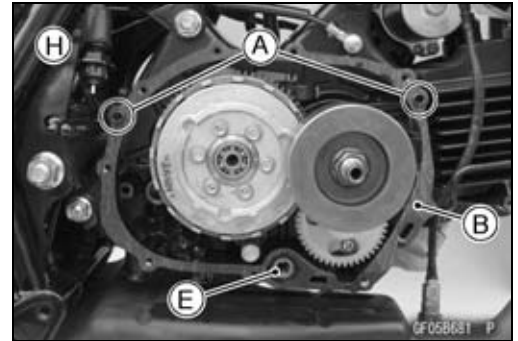
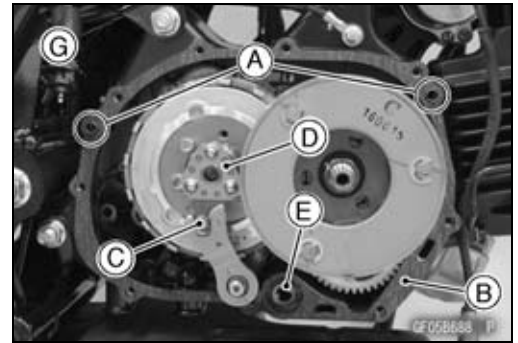

- Tighten the clutch cover bolts with the sequence [1 ~ 12] as shown.

**Torque - Clutch Cover Bolts: 8.8 N·m (0.90 kgf·m, 78 in·lb)**

- Run the oxygen sensor lead to the guides correctly (see Cable, Wire, and Hose Routing section in the Appendix chapter).
- Install the removed parts (see appropriate chapters).
- Pour in the specified engine oil (see Engine Oil Change in the Periodic Maintenance chapter).
- For BR125G, adjust the clutch (see Clutch Release Adjustment in the Periodic Maintenance chapter).
- For BR125H/J, adjust the clutch cable (see Clutch Operation Inspection in the Periodic Maintenance chapter).

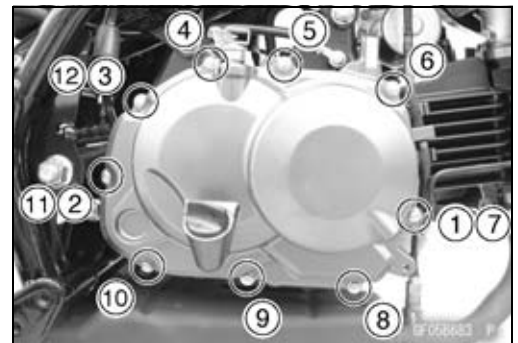

## 5-12 CLUTCH

### Clutch Cover

#### Release Shaft Removal (BR125H/J)

##### NOTICE

Do not remove the clutch release shaft unless it is absolutely necessary. If removed, release shaft oil seal must be replaced with a new one.

- Remove the clutch cover (see Clutch Cover Removal).
  - Remove the clutch pusher [A].
- 
- Pull the lever and shaft assembly [A] straight out of the clutch cover.

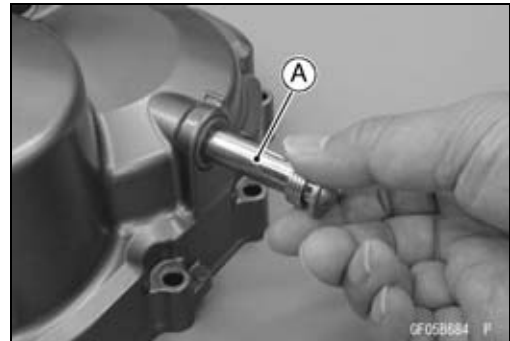

#### Release Shaft Installation (BR125H/J)

- Installation is the reverse of removal.
- Replace the oil seal [A] with a new one.
- Apply grease to the oil seal lips.
- Press in the oil seal until it is bottomed.
- Apply molybdenum disulfide oil solution to the clutch pusher.

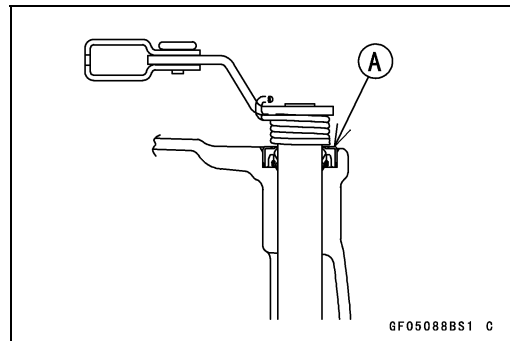

#### Clutch Cover Disassembly

- Remove:
    - Clutch Cover (see Clutch Cover Removal)
    - Oil Filler Cap/Dipstick [A]
    - O-ring
- 
- Remove:
    - Circlip [A]
    - Oil Seal [B]
- Special Tool - Inside Circlip Pliers: 57001-143

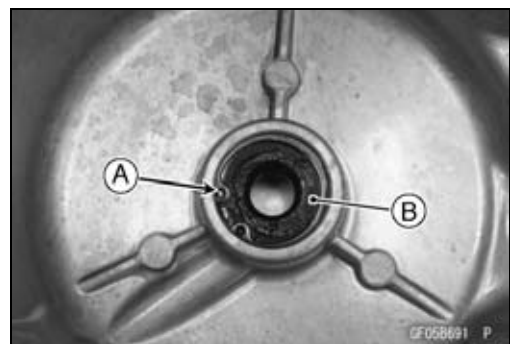
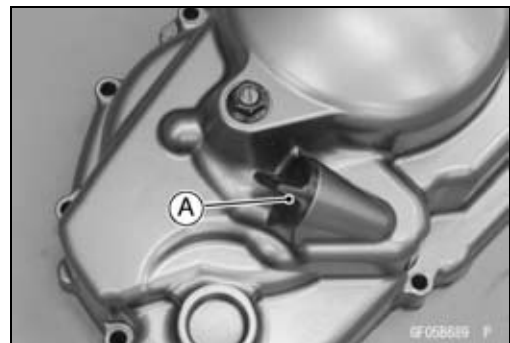

## Clutch Cover

### BR125G

- Remove:
  - Clutch Adjusting Screw Locknut [A]
  - Release Plate [B] and Release Shaft [C]

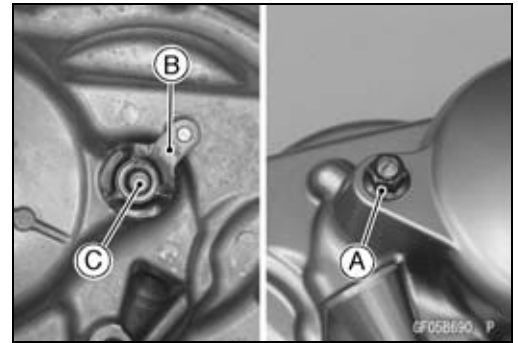

### BR125H/J

- Remove:
  - Release Lever and Shaft Assembly (see Release Shaft Removal)

### Clutch Cover Assembly

- Replace the O-ring, the oil seals and the circlip with new ones.
- Apply grease to the oil seal lips and O-ring.
- Install the oil seals so that the surfaces are flush with the edge of the clutch cover.

**Special Tool - Bearing Driver Set: 57001-1129**

- Install the circlip [A] into the groove in the clutch cover.

**Special Tool - Inside Circlip Pliers: 57001-143**

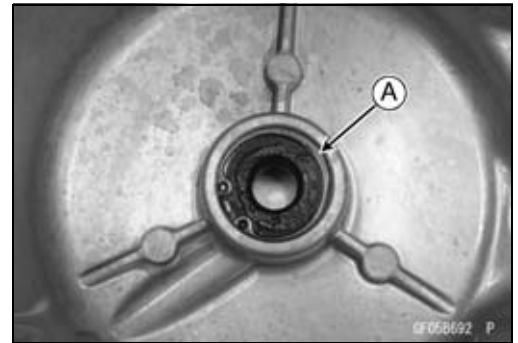

### BR125G

- Replace the O-ring [A] with a new one.
- Apply grease to the O-ring, and install it.
- Turn in the release plate [B] into the release shaft [C] fully but not tightly and then back it out the three turns, and insert it into the holes [D] of clutch cover securely.
- Tighten the locknut into the release shaft from the opposite side.

**Torque - Clutch Adjusting Screw Locknut: 19 N·m (1.9 kgf·m, 14 ft·lb)**

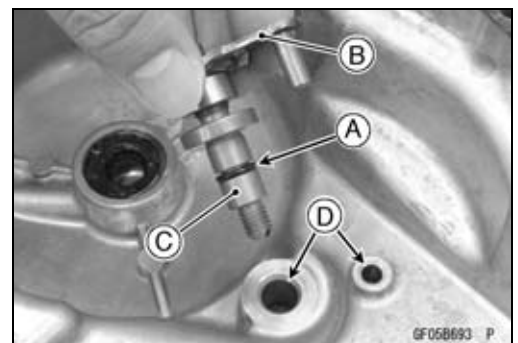

### BR125H/J

- Install the release lever and shaft assembly (see Release Shaft Installation).

## 5-14 CLUTCH

### Clutches

#### Clutch Removal (BR125G)

- Remove:
  - Clutch Cover (see Clutch Cover Removal)
  - Clutch Release Lever [A]
  - Release Ball Assembly [B]
  - Release Cam [C]
  - Ball Bearing [D]
  - Ball Bearing Holder [E]
- Remove the primary clutch hub nut [A] while holding the primary clutch steady with the clutch holder [B].  
**Special Tool - Clutch Holder 1: 57001-1507**
- Hold the secondary clutch with the gear holder [A].  
**Special Tool - Gear Holder: 57001-1602**
- Remove the secondary clutch hub nut [B].
- Remove the primary clutch [A] and secondary clutch [B] as a set.
- Remove:
  - Collar [A]
  - Spacer [B]

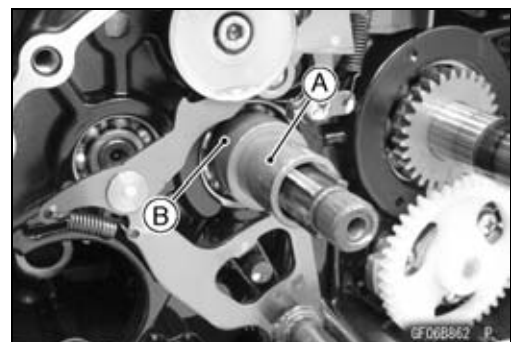
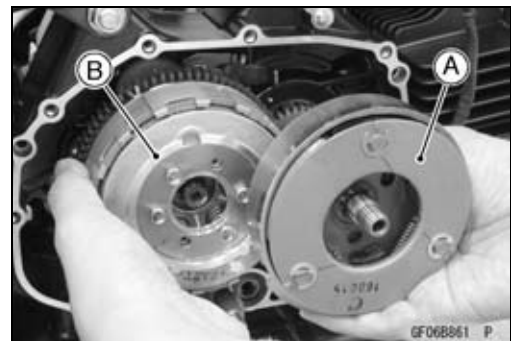
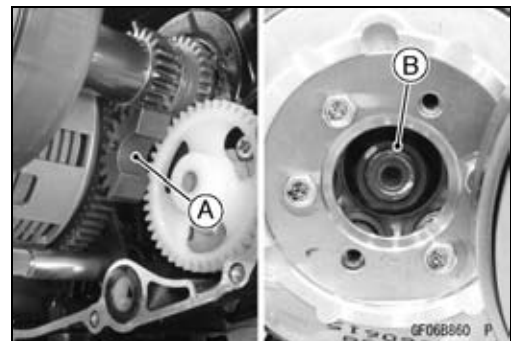
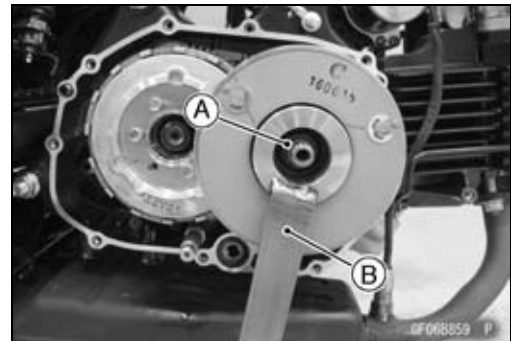
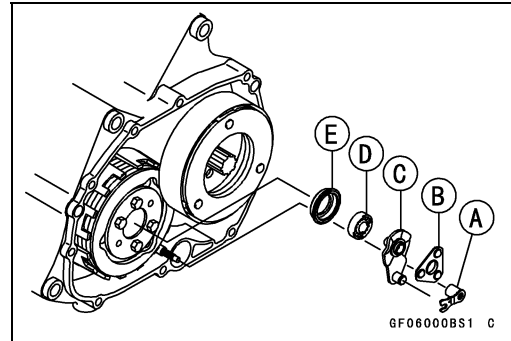

## Clutches

### Clutch Installation (BR125G)

★ If the primary clutch housing disassembled, assemble it as follows.

- Install the gear [A] to the primary clutch housing [B].
- Replace the circlip [C] with a new one, and install it.
- Install the spring [D] to the holder [E].
- Fit the tooth form of the gears, and press the holder to the clutch housing.
- Before installing the clutch housing, mark [F] on the tip of optional tooth (1 place).
- The gear shall be rotated clockwise [G] more than 1 tooth and less than 2 teeth (Confirm that making is rotated.).

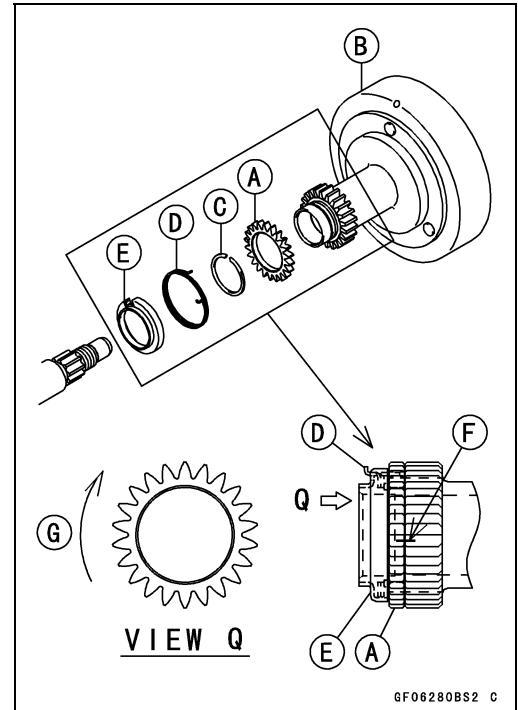

- Apply molybdenum disulfide oil solution to the drive shaft, crankshaft and collar [A].
- Install the spacer [B] and the collar to the drive shaft.
- Insert the primary and secondary clutches as a set.
- Hard to install the secondary clutch, turn the drive shaft while pushing the clutch.

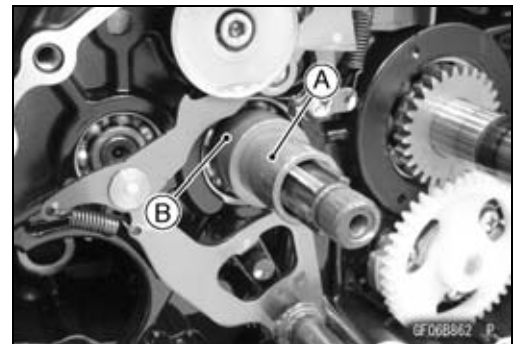

★ If the one-way clutch and race dropped from the primary clutch housing, install it as follows.

- Put the one-way clutch [A] in the clutch housing halfway with the rotation mark [B] facing out.
- Fit the race [C] with the machining unevenness side facing to the outside into the one-way clutch and while turn the clutch housing counterclockwise, push the race in the clutch housing.

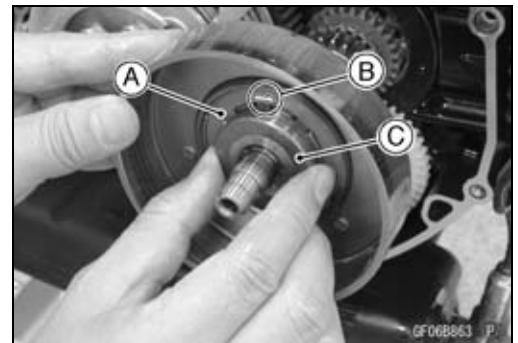

- Hold the secondary clutch with gear holder [A].
- Special Tool - Gear Holder: 57001-1602
- Tighten:
- Torque - Secondary Clutch Hub Nut [B]: 72 N·m (7.3 kgf·m, 53 ft·lb)

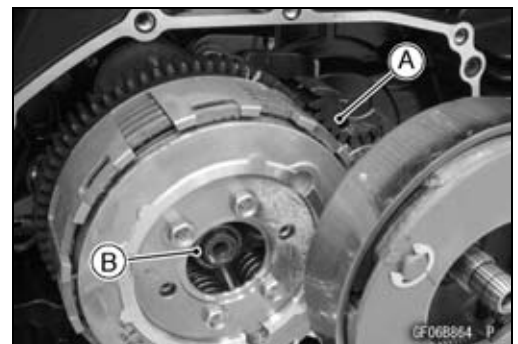

## 5-16 CLUTCH

### Clutches

- Tighten the primary clutch hub nut while holding the primary clutch steady with the clutch holder.

**Special Tool - Clutch Holder 1: 57001-1507**

**Torque - Primary Clutch Hub Nut: 72 N·m (7.3 kgf·m, 53 ft·lb)**

- Install the ball bearing holder [A] and the ball bearing [B].

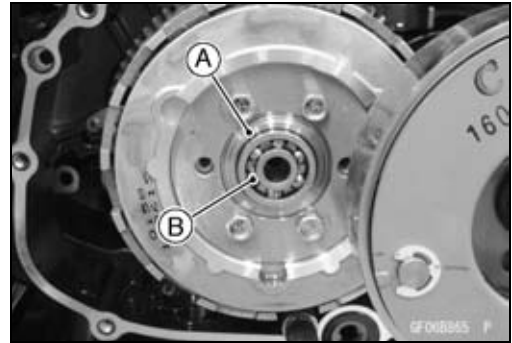

- Apply grease to the release ball assembly.
- Install the release cam [A] and the release ball assembly [B].
- Install the release lever [C] so that the lines [D] on the lever is aligning to the line [E] on the shift shaft.
- Install the clutch cover (see Clutch Cover Installation).
- Adjust the clutch (see Clutch Release Adjustment in the Periodic Maintenance chapter).

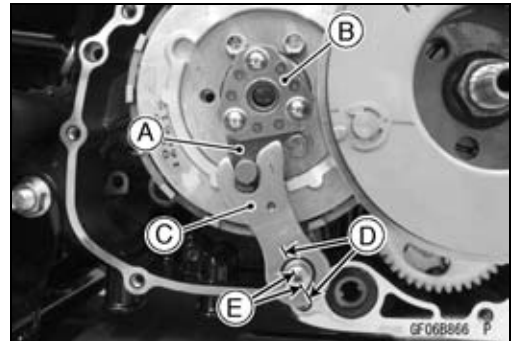

### **Clutch Removal (BR125H/J)**

- Remove the clutch cover (see Clutch Cover Removal).
- Hold the primary gear with the gear holder [A].

**Special Tool - Gear Holder: 57001-1602**

- Remove the primary gear nut [B].
- Remove the ball bearing and ball bearing holder [C].

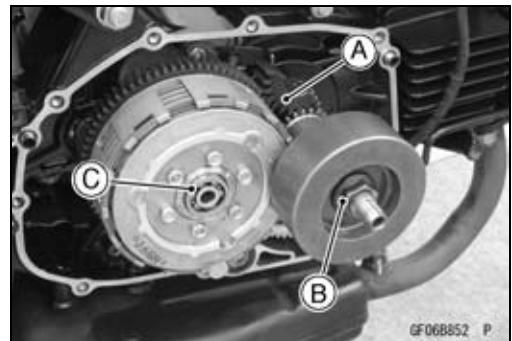

- Hold the clutch assembly with the gear holder [A].

**Special Tool - Gear Holder: 57001-1602**

- Remove the clutch hub nut [B].

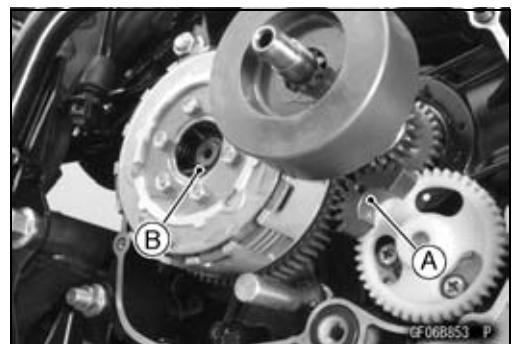

- Remove the primary gear [A] and clutch assembly [B] as a set.

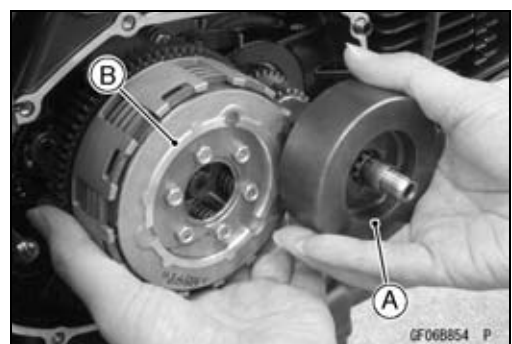

## Clutches

- Remove:
  - Collar [A]
  - Spacer [B]

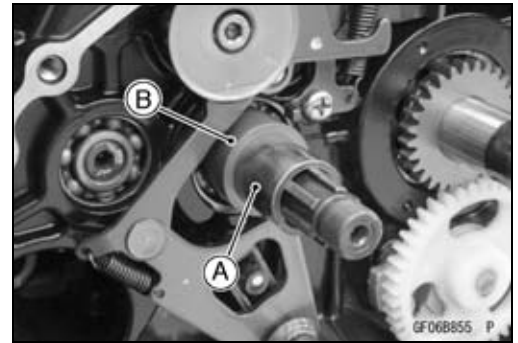

### Clutch Installation (BR125H/J)

- Apply molybdenum disulfide oil solution to the drive shaft and collar [A].
- Install the spacer [B] and the collar to the drive shaft.

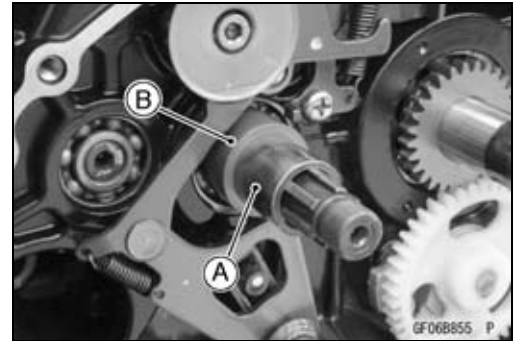

- Apply molybdenum disulfide oil solution to the crankshaft.
  - Install the primary gear [A] and clutch assembly [B] together.
- Hard to install the clutch assembly, turn the drive shaft while pushing the clutch.

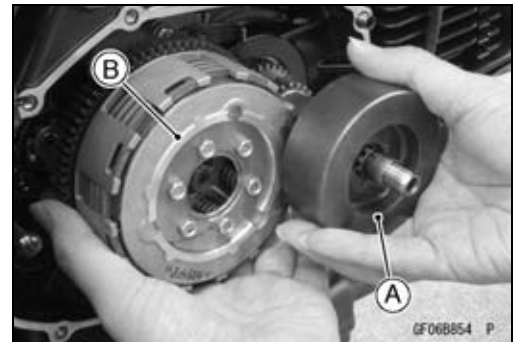

- Hold the clutch assembly with the gear holder [A].
  - Special Tool - Gear Holder: 57001-1602**
- Tighten:
  - Torque - Clutch Hub Nut [B] : 72 N·m (7.3 kgf·m, 53 ft·lb)**

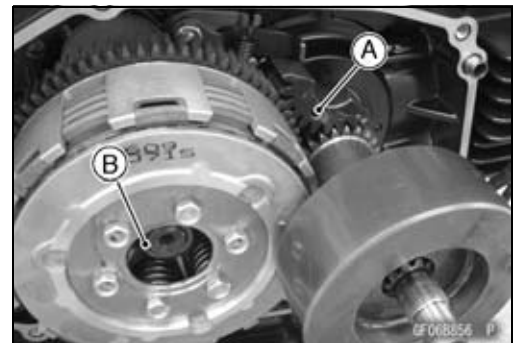

- Hold the primary gear with the gear holder [A].
  - Special Tool - Gear Holder: 57001-1602**
- Tighten:
  - Torque - Primary Gear Nut [B]: 72 N·m (7.3 kgf·m, 53 ft·lb)**

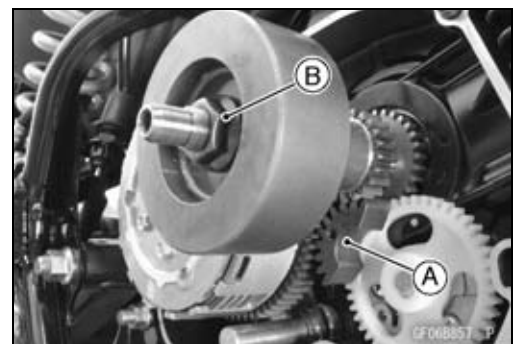

## 5-18 CLUTCH

### Clutches

- Install the ball bearing holder and ball bearing [A].
- Install the clutch cover (see Clutch Cover Installation).



### Clutch Disassembly

- Remove the clutch (see Clutch Removal).
- Remove the clutch spring bolts [A], spring plate [B] and the springs [C].

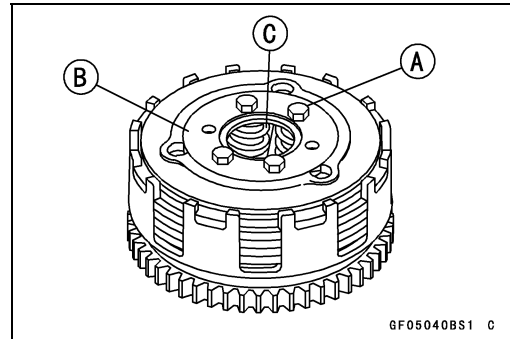

- Remove the clutch hub [A] and clutch wheel [B].
- Remove the clutch plates [C].

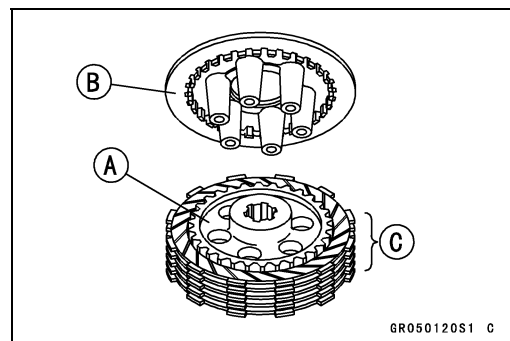

### Clutch Assembly

- Install the friction plates [A] and steel plates [B] on the clutch hub [C], starting with a friction plate and alternating them.

#### BR125G

- The grooves [D] on the friction plate surfaces are cut tangentially and radially. Install the friction plates (13088 -1142) so that the grooves run toward the center in the direction of the clutch housing rotation (clockwise viewed from the engine left side).

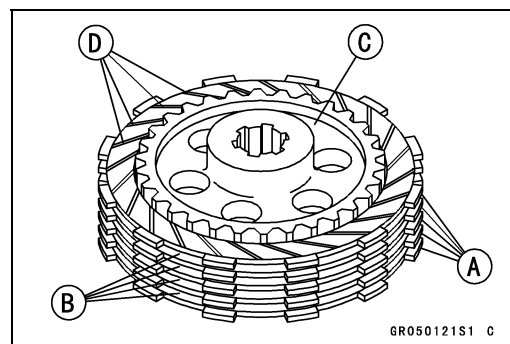

### NOTICE

If new dry steel plates and friction plates are installed, apply engine oil to the surfaces of each plate to avoid clutch plate seizure.



Clutches

**BR125H/J**

- Place the two oblique groove type friction plates (13088-1142) [A] to both ends. Also, install the oblique groove on the friction plates so that the grooves run toward the center in the direction of the clutch housing rotation [B].
- Install the three radial groove type friction plates (13088-0048) [C] between the steel plates [D].

**NOTICE**

**If new dry steel plates and friction plates are installed, apply engine oil to the surfaces of each plate to avoid clutch plate seizure.**

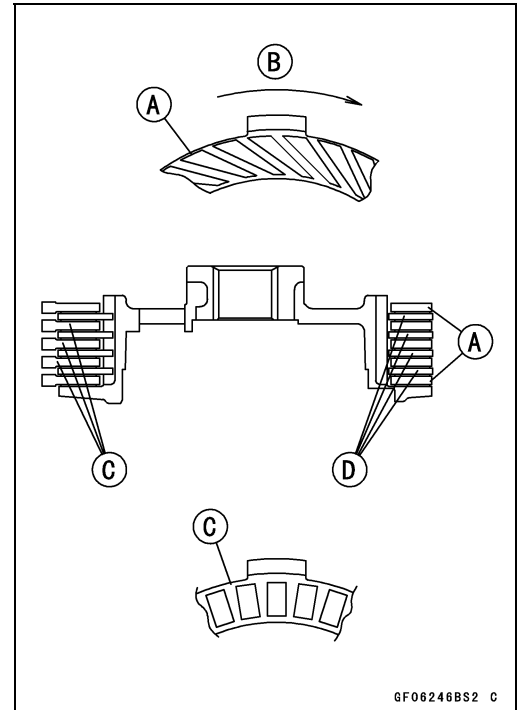

- Install the clutch wheel on the clutch hub.
- Install the clutch spring plate [A] with the springs and the spring bolts temporarily and fit the clutch hub and plate assembly into the clutch housing [B].

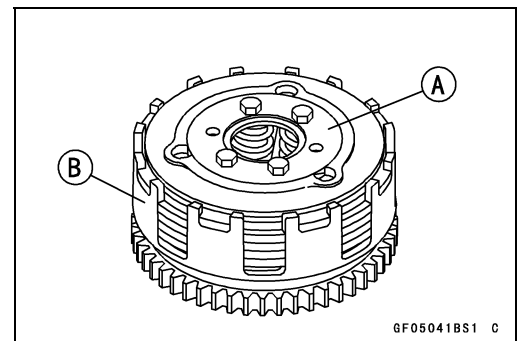

- Install the last friction plate [A] fitting the tangs in the grooves on the housing as shown.
- Temporarily install the clutch assembly to the drive shaft (see Clutch Installation).
- Tighten:

**Torque - Secondary Clutch Spring Bolts (BR125G): 5.0 N·m (0.51 kgf·m, 44 in·lb)**  
**Clutch Spring Bolts (BR125H/J): 5.0 N·m (0.51 kgf·m, 44 in·lb)**

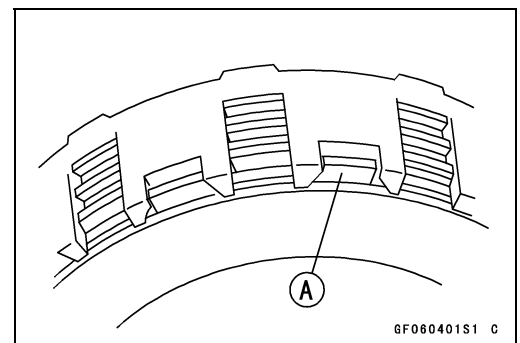

**Primary Clutch Housing Wear Inspection (BR125G)**

- Measure the inside diameter [A] of the clutch housing sliding surface.
- Use a vernier caliper and measure at several points.
- ★ If any measurement exceeds the service limit, replace the primary clutch housing.

**Primary Clutch Housing Inside Diameter**  
**Standard: 104.0 ~ 104.2 mm (4.094 ~ 4.102 in.)**  
**Service Limit: 104.5 mm (4.114 in.)**

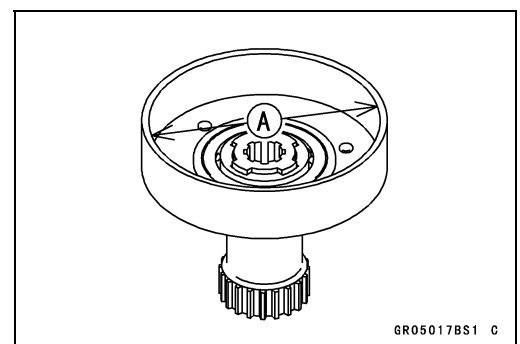

## 5-20 CLUTCH

### Clutches

#### Primary Clutch Shoe Lining Wear Inspection (BR125G)

- Remove the primary clutch hub (see Clutch Removal).
- Visually inspect the primary clutch shoe linings [A] for uneven wear, discoloration, missing friction material, cracks or other damage.
- ★ If any of the linings are damaged, replace the primary clutch hub.

- Measure the groove depth [A].
- Use a depth gauge, and measure at several points.
- ★ If any measurement less than the service limit, replace the primary clutch hub.

#### Primary Clutch Shoe Groove Depth

Standard: 1.0 mm (0.04 in.)

Service Limit: 0.5 mm (0.02 in.)

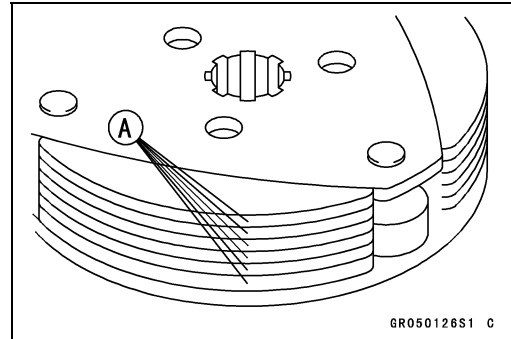
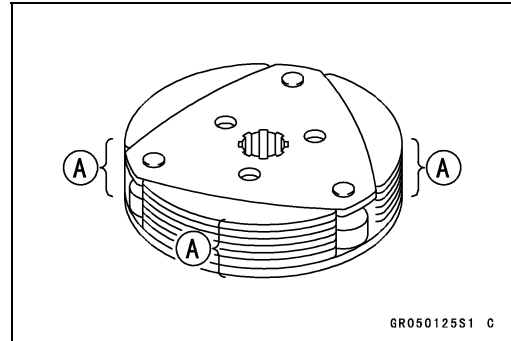

#### One-Way Clutch Inspection (BR125G)

- Remove the clutch cover (see Clutch Cover Removal).
- Turn the primary clutch housing by hand. When view from the right side of the engine, the primary clutch housing should turn counterclockwise [A] freely but should not turn clockwise.

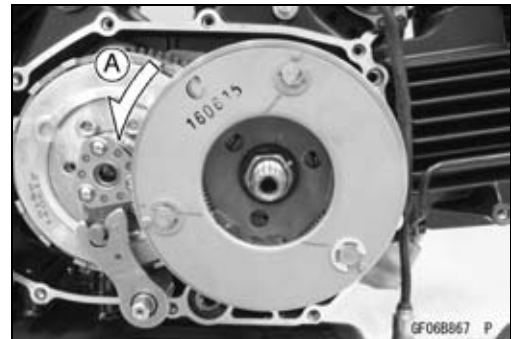

- ★ If the one-way clutch does not operate as it should or if it makes noise, go to the next steps.
- Remove the primary clutch.
- Check that the one-way clutch [A] is installed so that the rotation mark faces out.
- Visually inspect the one-way clutch and the race [B] in the primary clutch housing.
- ★ If there is any worn or damaged part, replace it.
- Check that the rollers [C] in the one-way clutch is installed when viewed from the right side of the engine.

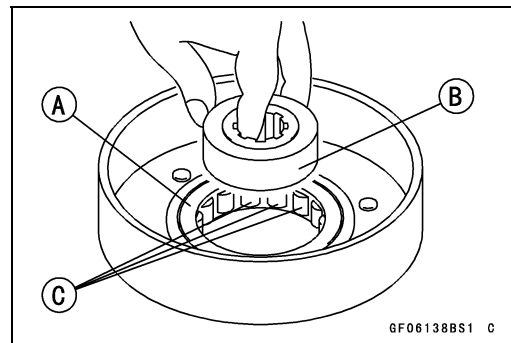

## Clutches

### Clutch Plate Wear and Damage Inspection

- Visually inspect the friction and steel plates for uneven wear, discoloration, missing friction material, cracks or other damage.
- ★ If any plates show signs of damaged, replace the friction and steel plates as a set.
- Measure the thickness of the friction plates [A] at several points.

#### Friction Plate Thickness

##### Standard:

13088-1142 (oblique groove type plate)	3.10 ~ 3.30 mm (0.122 ~ 0.130 in.)
13088-0048 (radial groove type plate)	3.12 ~ 3.28 mm (0.123 ~ 0.129 in.)

##### Service Limit:

13088-1142 (oblique groove type plate)	2.9 mm (0.11 in.)
13088-0048 (radial groove type plate)	3.0 mm (0.12 in.)

- ★ If any of the measurement is less than the service limit, replace the plates as a set.

### Clutch Plate Warp Inspection

- Place each friction plate or steel plate [A] on a surface plate [B] and measure the gap between the surface plate and each plate with a thickness gauge [C]. The gap is the amount of friction and steel plate warp.
- ★ If any of the clutch plate is warped beyond the service limit, replace the plate with a new one.

#### Friction Plate Warp

##### Standard:

13088-1142 (oblique groove type plate)	0.2 mm (0.008 in.) or less
13088-0048 (radial groove type plate)	0.15 mm (0.0059 in.) or less

##### Service Limit:

13088-1142 (oblique groove type plate)	0.3 mm (0.01 in.)
13088-0048 (radial groove type plate)	0.3 mm (0.01 in.)

#### Steel Plate Warp

Standard:	0.15 mm (0.0059 in.) or less
Service Limit:	0.3 mm (0.01 in.)

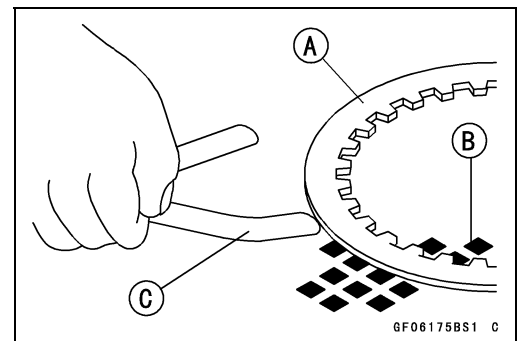
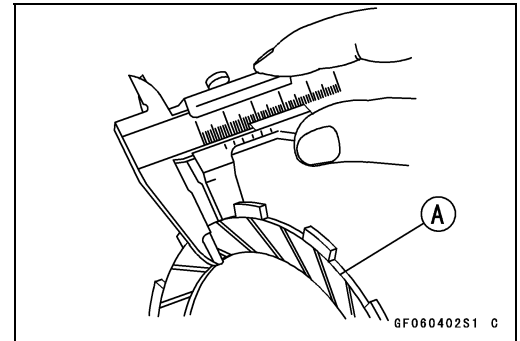

## 5-22 CLUTCH

### Clutches

#### **Clutch Housing Finger Damage Inspection**

- Visually inspect the clutch housing finger [A] where the friction plate tangs [B] hit them.
- ★ If they are badly worn or if there are groove cuts where the tangs hit, replace the housing. Also, replace the friction plates if their tangs are damaged.

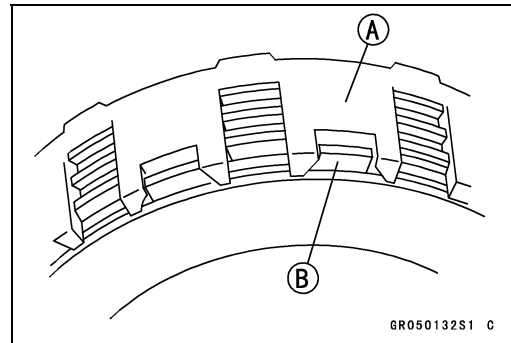

#### **Clutch Hub Spline Damage Inspection**

- Visually inspect where the teeth on the steel plates wear against the clutch hub splines.
- ★ If there are notches worn into the clutch hub splines [A], replace the clutch hub. Also, replace the steel plates if their teeth are damaged.

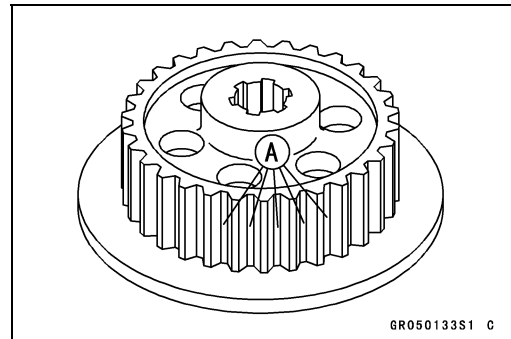

#### **Clutch Spring Inspection**

- ★ If all the components are good, but the problem still exists, replace the clutch springs (see Clutch Removal and Clutch Installation).

# Engine Lubrication System

## Table of Contents

Exploded View.....	6-2
Engine Oil Flow Chart.....	6-4
Specifications .....	6-5
Special Tools .....	6-6
Engine Oil and Oil Filter.....	6-7
Oil Level Inspection.....	6-7
Engine Oil Change.....	6-7
Oil Filter Replacement .....	6-8
Oil Screen Removal .....	6-8
Oil Screen Installation .....	6-8
Oil Screen Cleaning .....	6-8
Oil Pump.....	6-9
Oil Pump Removal .....	6-9
Oil Pump Installation .....	6-9
Oil Pump Inspection.....	6-9
Oil Pressure Measurement.....	6-10
Oil Pressure Measurement .....	6-10
Oil Pipe.....	6-11
Oil Pipe Removal .....	6-11
Oil Pipe Installation .....	6-11

# 6-2 ENGINE LUBRICATION SYSTEM

## Exploded View

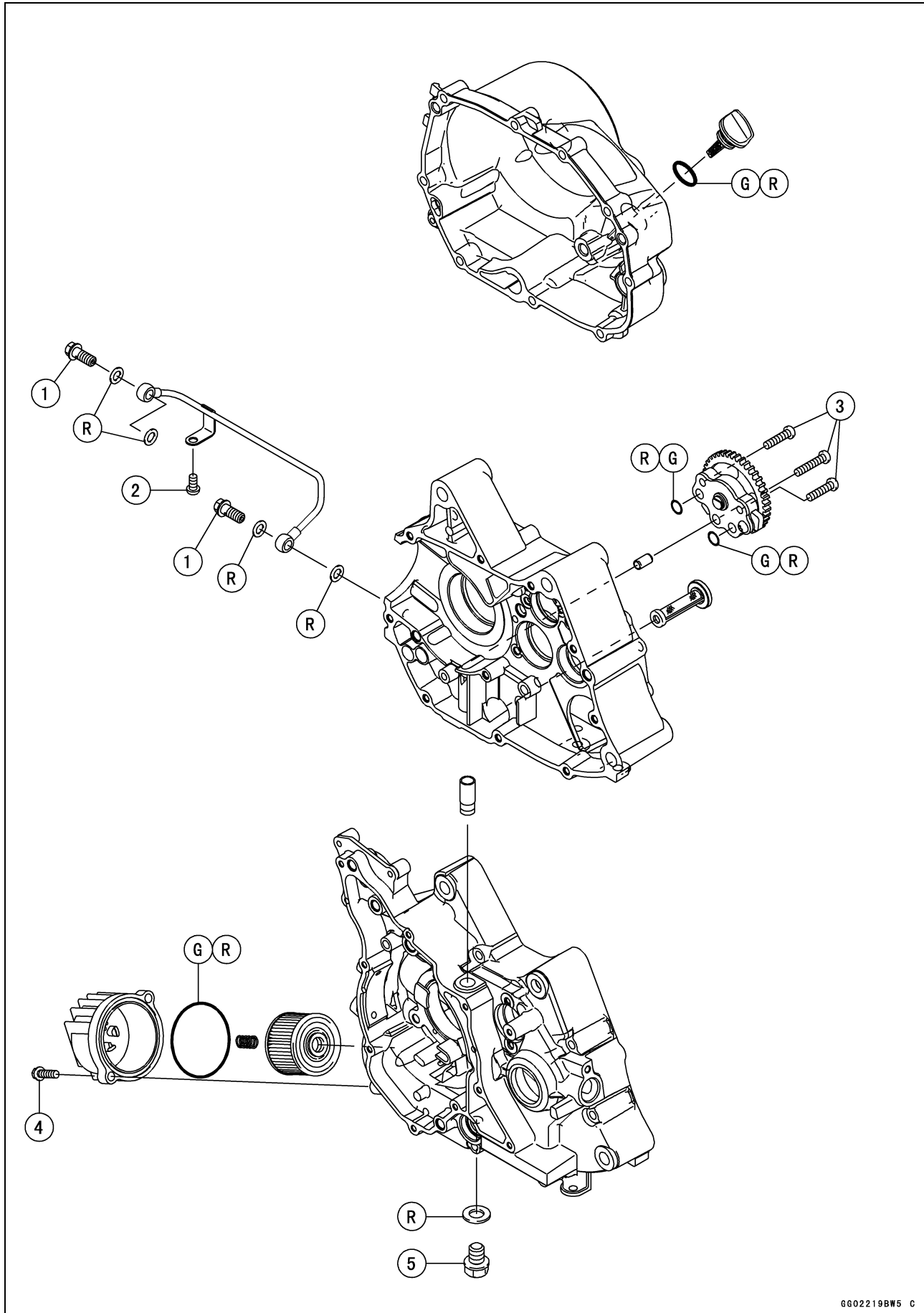

## ENGINE LUBRICATION SYSTEM 6-3

### Exploded View

No.	Fastener	Torque			Remarks
		N·m	kgf·m	ft·lb	
1	Oil Pipe Banjo Bolts	15	1.5	11	
2	Oil Pipe Mounting Screw	5.2	0.53	46 in·lb	
3	Oil Pump Mounting Screws	5.2	0.53	46 in·lb	
4	Oil Filter Cap Bolts	5.2	0.53	46 in·lb	
5	Engine Oil Drain Bolt	29	3.0	21	

G: Apply grease.

R: Replacement Parts

## 6-4 ENGINE LUBRICATION SYSTEM

### Engine Oil Flow Chart

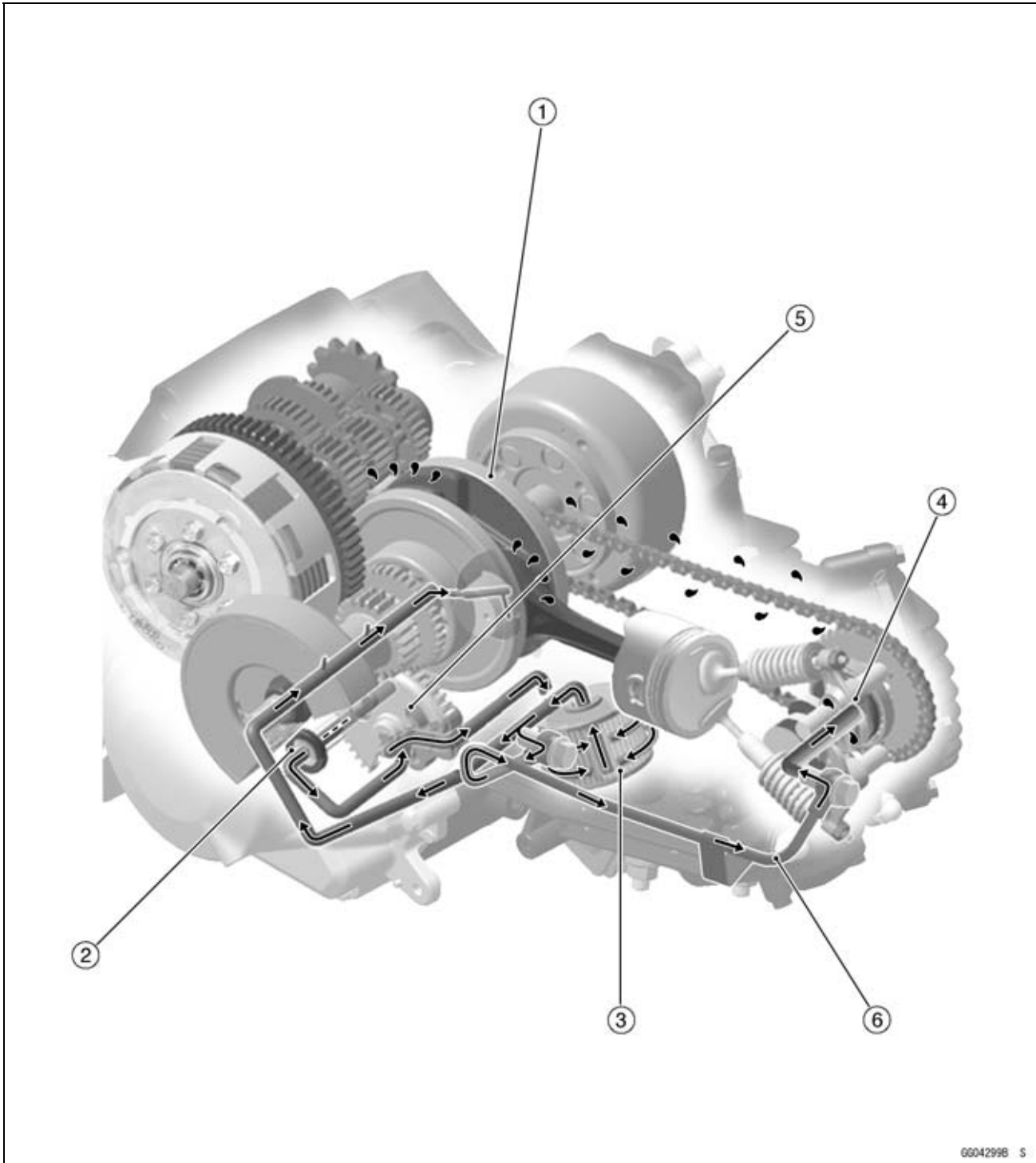

1. Crankshaft
2. Oil Screen
3. Oil Filter
4. Camshaft
5. Oil Pump
6. Oil Pipe



## ENGINE LUBRICATION SYSTEM 6-5

### Specifications

Item	Standard
<b>Engine Oil</b> Type Viscosity Capacity:  Level	API SG, SH, SJ, SL or SM with JASO MA, MA1 or MA2 SAE 10W-40 0.8 L (0.8 US qt) (When filter is not removed.) 0.9 L (1.0 US qt) (When filter is removed.) 1.0 L (1.1 US qt) (When engine is completely dry.) Between upper and lower level lines on the dipstick (Wait several minutes after idling or running)
<b>Oil Pressure Measurement</b> Oil Pressure	88 ~ 147 kPa (0.90 ~ 1.50 kgf/cm <sup>2</sup> , 13 ~ 21 psi) @4 000 r/min (rpm), Oil Temperature 50°C (122°F)

## 6-6 ENGINE LUBRICATION SYSTEM

### Special Tools

**Oil Pressure Gauge, 5 kgf/cm<sup>2</sup>:**  
**57001-125**

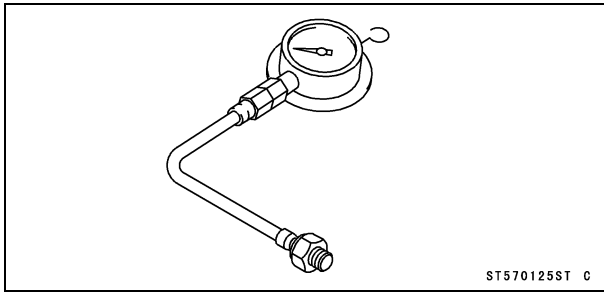

**Oil Pressure Cap:**  
**57001-1651**

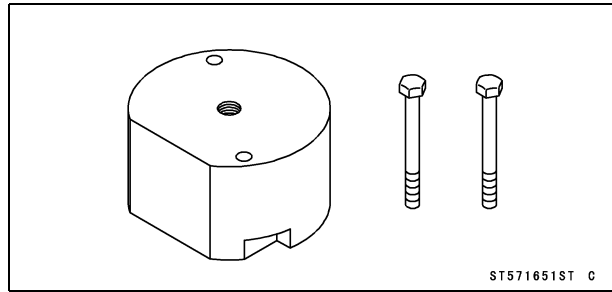

**Oil Pressure Gauge Adapter, M10 × 1.25:**  
**57001-1182**

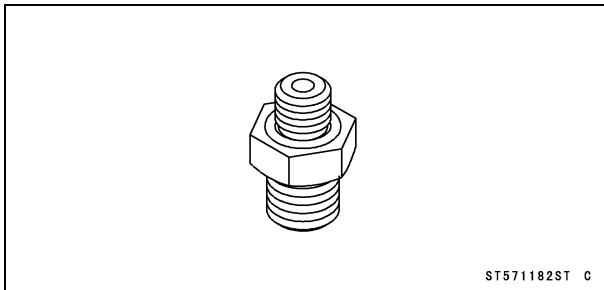

## Engine Oil and Oil Filter

### **⚠ WARNING**

Vehicle operation with insufficient, deteriorated, or contaminated engine oil will cause accelerated wear and may result in engine seizure, accident, and injury. Check the oil level before each use and change the oil and filter according to the periodic maintenance chart.

### **Oil Level Inspection**

- With the motorcycle held level, unscrew the oil filler cap/dipstick [A].
- Wipe the dipstick sufficiently, and screw it fully.
- Unscrew the oil filler cap/dipstick again.



- Check that the engine oil level is between the upper [A] and lower [B] levels in the dipstick.

### **NOTE**

- If the motorcycle has just been used, wait several minutes for all the oil to drain down.
- If the oil has just been changed, start the engine and run it for several minutes at idle speed. This fills the oil filter with oil. Stop the engine, then wait several minutes until the oil settles.

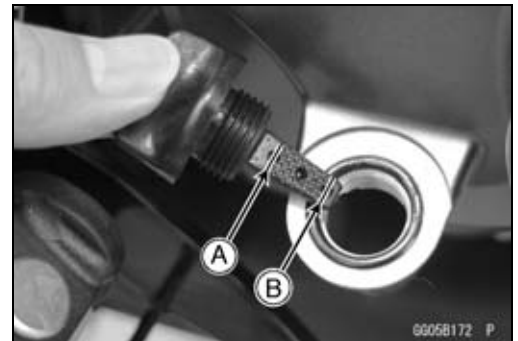

### **NOTICE**

**Racing the engine before the oil reaches every part can cause engine seizure.**

- ★ If the oil level is too high, remove the excess oil, using a syringe or other suitable device.
- ★ If the oil level is too low, add the correct amount of oil. Use the same type and make of oil that is already in the engine.

### **NOTE**

- If the engine oil type and make are unknown, use any brand of the specified oil to top off the level rather than running the engine with the oil level low. Then at your earliest convenience, change the oil completely.

- Replace the O-ring with a new one.
- Apply grease to the new O-ring.
- Install the O-ring on the oil filler neck correctly first, then install the oil filler cap/dipstick.

### **NOTE**

- Do not pinch the O-ring when installing the dipstick on the oil filler neck.

### **Engine Oil Change**

- Refer to the Engine Oil Change in the Periodic Maintenance chapter.

## 6-8 ENGINE LUBRICATION SYSTEM

### Engine Oil and Oil Filter

#### **Oil Filter Replacement**

- Refer to the Oil Filter Replacement in the Periodic Maintenance chapter.

#### **Oil Screen Removal**

- Drain the engine oil (see Engine Oil Change in the Periodic Maintenance chapter).
- Remove:
  - Clutch Cover (see Clutch Cover Removal in the Clutch chapter)
  - Oil Screen [A]

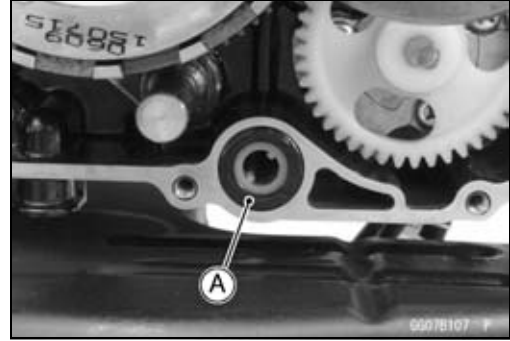

#### **Oil Screen Installation**

- Check the screen carefully for any damage.
- ★ Replace the screen with a new one if it is damaged.
- Install:
  - Oil Screen
  - Clutch Cover (see Clutch Cover Installation in the Clutch chapter)

#### **Oil Screen Cleaning**

- Remove the oil screen (see Oil Screen Removal).
- Clean the screen with high flash-point solvent, and then dry it.
- Clean the screen thoroughly whenever the engine oil is changed.

#### **NOTE**

○ While cleaning the screen, check for any metal particles that engine indicate internal damage.

#### **⚠ WARNING**

**Gasoline and low flash-point solvents can be flammable and/or explosive and cause severe burns. Clean the oil screen in a well-ventilated area, and take care that there are no sparks or flame anywhere near the working area; this includes any appliance with a pilot light. Do not use gasoline or a low flash-point solvent to clean the oil screen.**

- Install the oil screen (see Oil Screen Installation).

## Oil Pump

### Oil Pump Removal

- Drain the engine oil (see Engine Oil Change in the Periodic Maintenance chapter).
- Remove:
  - Clutch Cover (see Clutch Cover Removal in the Clutch chapter)
- For BR125G, remove the clutch (see Clutch Removal in the Clutch chapter).
- Turn the crankshaft so that the oil pump mounting screws [A] can be removed through the pump gear holes.
- Remove the oil pump mounting screws and the oil pump assembly [B].

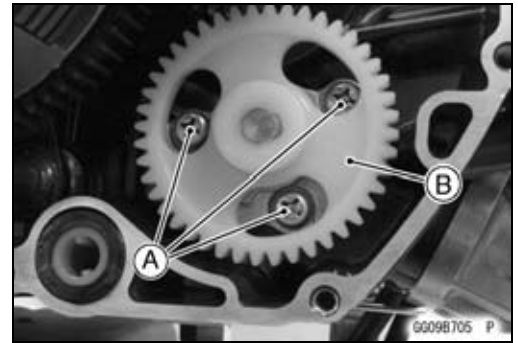

### Oil Pump Installation

- Replace the O-rings [A] with new ones.
- Apply grease to the O-rings.
- Check to see that the O-rings and the dowel pin [B] are in place.

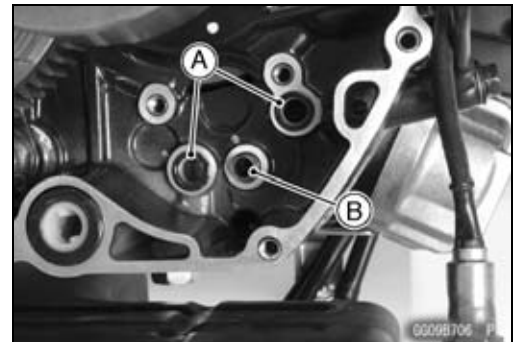

- Install the oil pump and the oil pump mounting screws [A].
  - The lower screw [B] is longer than the other ones.
  - Be sure the oil pump gear [C] and pump drive gear [D] on the crankshaft mesh properly.
- Tighten:
  - Torque - Oil Pump Mounting Screws: 5.2 N·m (0.53 kgf·m, 46 in·lb)**

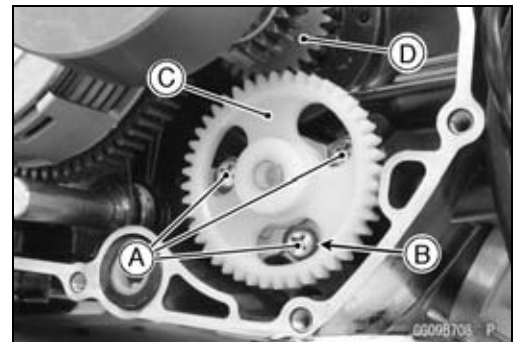

### Oil Pump Inspection

- Visually inspect the oil pump body [A] and the gear [B].
- ★ If there is any damage or uneven wear, replace the oil pump assembly.
- Turn the gear by hand to inspect the condition of the oil pump.
- ★ If the rotation of the pump is noisy, does not turn smoothly or has any rough spots, replace the oil pump assembly.

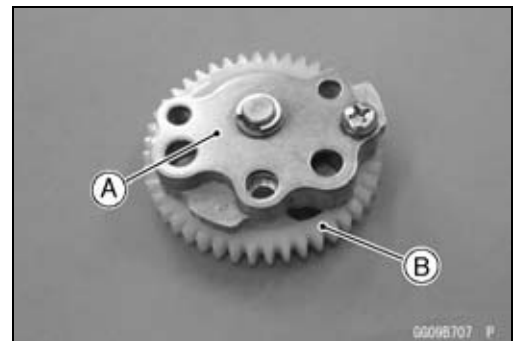

### NOTICE

**Do not disassemble the oil pump, because the individual parts of pump are not supplied.**

## 6-10 ENGINE LUBRICATION SYSTEM

### Oil Pressure Measurement

#### Oil Pressure Measurement

- Remove the oil filter cap (see Oil Filter Replacement in the Periodic Maintenance chapter).
- Move the oil filter cap spring [A] and the O-ring [B] to the oil pressure cap [C].

**Special Tool - Oil Pressure Cap: 57001-1651**

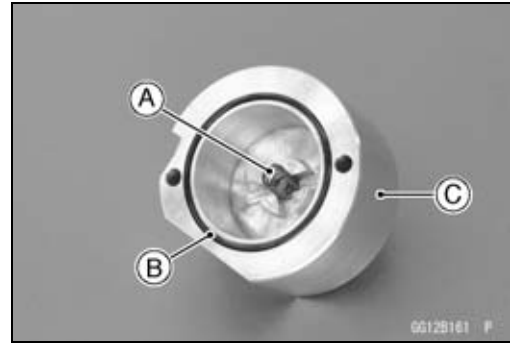

- Attach the oil pressure cap [A], adapter [B] and gauge [C].

**Special Tools - Oil Pressure Gauge, 5 kgf/cm<sup>2</sup>: 57001-125**  
**Oil Pressure Gauge Adapter, M10 × 1.25: 57001-1182**

- Start the engine and warm up it thoroughly.
- Run the engine at the specified speed, and read the oil pressure gauge.
- ★ If the oil pressure is much lower than the standard, check the oil pump and oil seal.
- ★ If the reading is much higher than the standard, check the oil pump screen and oil filter first, oil passages for clogging.

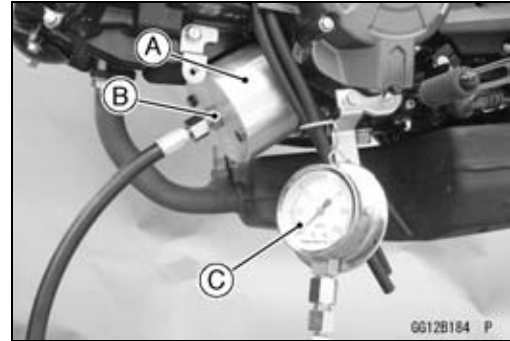

#### Oil Pressure

**Standard: 88 ~ 147 kPa (0.90 ~ 1.50 kgf/cm<sup>2</sup>, 13 ~ 21 psi) @4 000 r/min (rpm), Oil Temperature 50°C (122°F)**

- Stop the engine, and remove the oil pressure gauge, adapter and oil pressure cap.

#### **⚠ WARNING**

**Hot oil can cause severe burns. Beware of hot engine oil that will drain through the oil passage when the oil pressure gauge adapter is removed.**

- Install the oil filter cap (see Oil Filter Replacement in the Periodic Maintenance chapter).

### Oil Pipe

#### **Oil Pipe Removal**

- Drain the engine oil (see Engine Oil Change in the Periodic Maintenance chapter).
- Remove:
  - Lower Fairing (see Lower Fairing Removal in the Frame chapter)
  - Oil Pipe Banjo Bolts [A]
  - Oil Pipe Mounting Screw [B]
  - Oil Pipe [C]

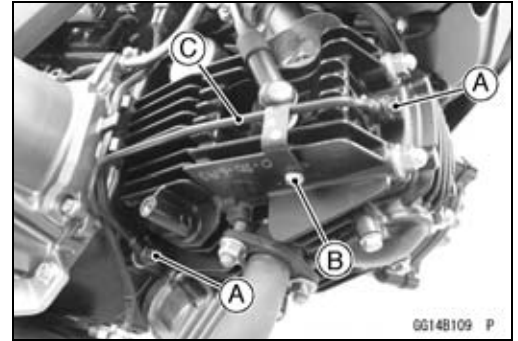

#### **Oil Pipe Installation**

- Before installation, flush out the pipe with high flash-point solvent.
- Replace the washers on each side of the pipe fittings.
- Lightly tighten the banjo bolts and oil pipe mounting screw to a snug fit, and tighten them to the specified torque.

**Torque - Oil Pipe Banjo Bolts: 15 N·m (1.5 kgf·m, 11 ft·lb)**  
**Oil Pipe Mounting Screw: 5.2 N·m (0.53 kgf·m, 46 in·lb)**





# Engine Removal/Installation

## Table of Contents

Exploded View.....	7-2
Engine Removal/Installation .....	7-4
Engine Removal.....	7-4
Engine Installation.....	7-5

## 7-2 ENGINE REMOVAL/INSTALLATION

### Exploded View

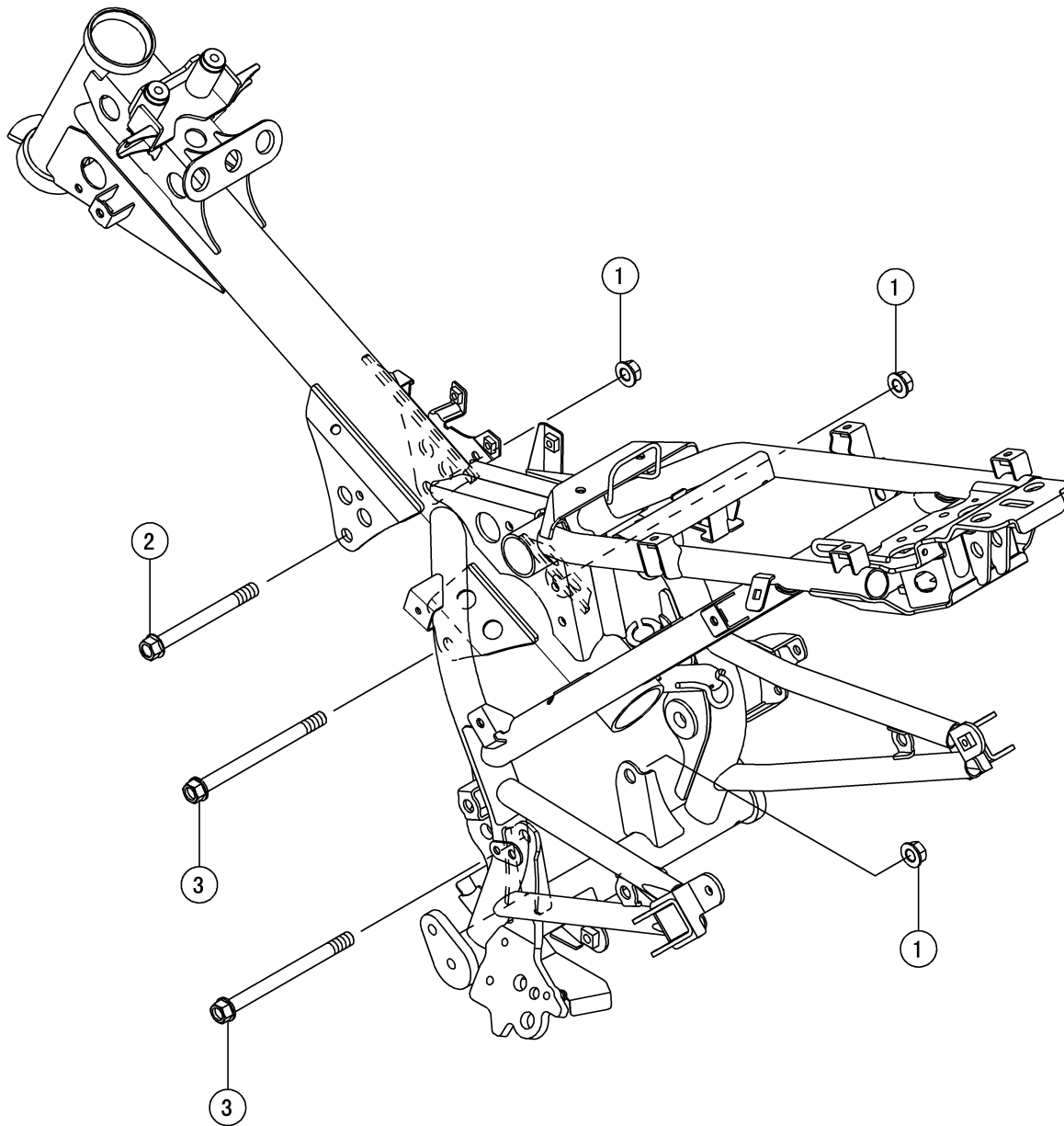

## ENGINE REMOVAL/INSTALLATION 7-3

### Exploded View

No.	Fastener	Torque			Remarks
		N·m	kgf·m	ft·lb	
1	Engine Mounting Nuts	59	6.0	44	

2. Engine Mounting Bolt (L = 100 mm, 3.94 in.)
3. Engine Mounting Bolts (L = 125 mm, 4.92 in.)

## 7-4 ENGINE REMOVAL/INSTALLATION

### Engine Removal/Installation

#### Engine Removal

- Squeeze the brake lever slowly and hold it with a band [A].

#### **⚠ WARNING**

**Motorcycle may fall over unexpectedly resulting in an accident or injury. Be sure to hold the front brake when removing the engine.**

#### **NOTICE**

**Be sure to hold the front brake when removing the engine, or the motorcycle may fall over. The engine or the motorcycle could be damaged.**

- Drain the engine oil (see Engine Oil Change in the Periodic Maintenance chapter).
- Remove:
  - Middle Fairings (see Middle Fairing Removal in the Frame chapter)
  - Lower Fairing (see Lower Fairing Removal in the Frame chapter)
  - Muffler (see Muffler Removal in the Engine Top End chapter)
  - Clutch Cable Lower End (see Clutch Cable Removal in the Clutch chapter) (BR125H/J)
  - Shift Pedal (see Shift Pedal Removal in the Crankshaft/Transmission chapter)
  - Front Footpeg Brackets (see Front Footpeg Bracket Removal in the Frame chapter)
  - Air Cleaner Housing (see Air Cleaner Housing Removal in the Fuel System (DFI) chapter)
  - Engine Temperature Sensor (see Engine Temperature Sensor Removal in the Fuel System (DFI) chapter)
  - Engine Sprocket (see Engine Sprocket Removal in the Final Drive chapter)
- Remove:
  - Intake Pipe Bolts [A] and Washers
- Disconnect:
  - Spark Plug Cap [B]

#### **NOTICE**

**When removing the spark plug cap, do not pull the lead. The lead could be broken off or damaged the wires inside.**

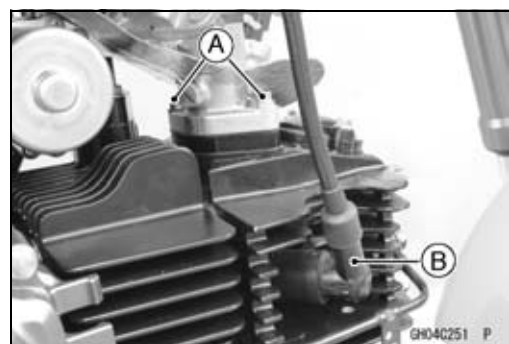
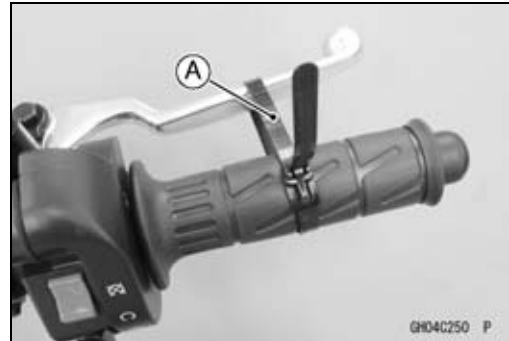

## Engine Removal/Installation

- Remove:  
Engine Ground Terminal Bolt [A]

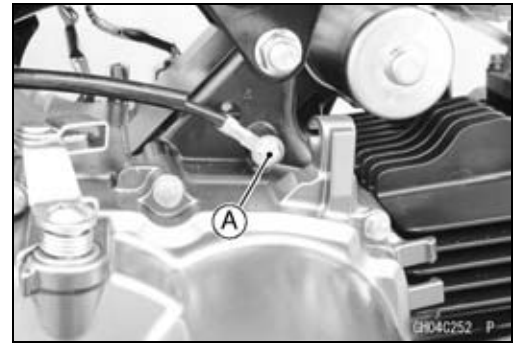

- Disconnect:  
Alternator Lead Connector [A]  
Crankshaft Sensor Lead Connector [B]  
Gear Position Switch Lead Connector [C]  
Starter Motor Lead Connector [D]

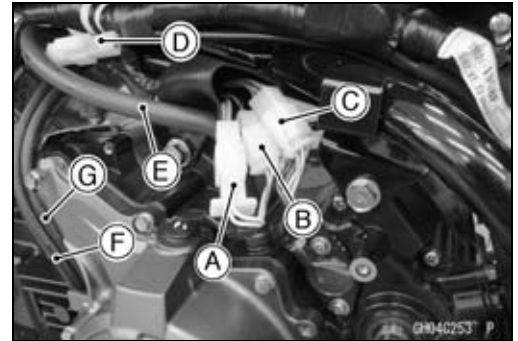

- Remove:  
Breather Hose [E]
- Free the fuel drain hose [F] and fuel breather hose [G] (other than CAL models) from the guides.

- Disconnect the speed sensor lead connector [A].

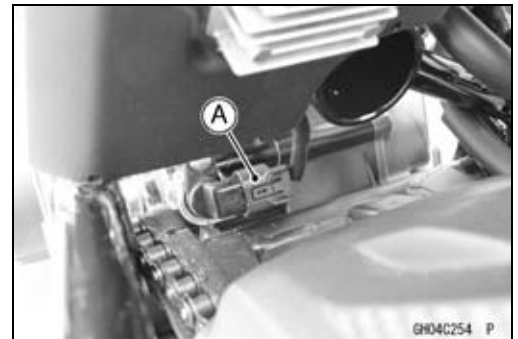

- Support the engine with a suitable stand [A].  
○ If necessary, put some suitable wooden blocks [B].
- Remove the engine mounting nuts [C] and bolts, and dismount the engine.

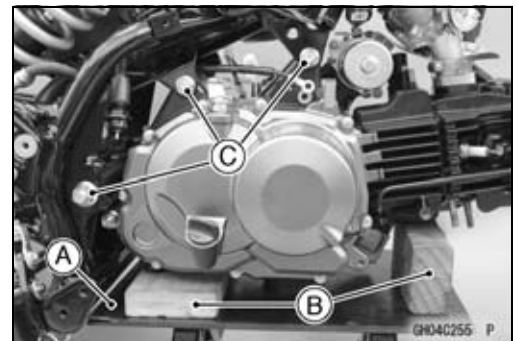

### **Engine Installation**

- Installation is the reverse of removal.
- Insert the engine mounting bolts from left side.
- Tighten:  
**Torque - Engine Mounting Nuts: 59 N·m (6.0 kgf·m, 44 ft·lb)**

## 7-6 ENGINE REMOVAL/INSTALLATION

---

### Engine Removal/Installation

---

- Run the cables, hoses and leads according to the Cable, Wire, and Hose Routing section in the Appendix chapter.
- Install the removed parts (see appropriate chapters).
- Fill the engine oil (see Engine Oil Change in the Periodic Maintenance chapter).
- Adjust:
  - Throttle Cable (see Throttle Control System Inspection in the Periodic Maintenance chapter)
  - Clutch Cable (see Clutch Operation Inspection in the Periodic Maintenance chapter) (BR125H/J)
  - Drive Chain (see Drive Chain Slack Adjustment in the Periodic Maintenance chapter)
- Check the brake effectiveness.

** WARNING**

**After servicing, it takes several applications of the brake lever or pedal before the brake pads contact the disc, which could result in increased stopping distance and cause an accident resulting in injury or death. Do not attempt to ride the motorcycle until a firm brake lever or pedal is obtained by pumping the lever or pedal until the pads are against the disc.**

# Crankshaft/Transmission

## Table of Contents

Exploded View .....	8-2
Specifications .....	8-6
Special Tools and Sealant .....	8-7
Crankcase Splitting.....	8-8
Crankcase Splitting .....	8-8
Crankcase Assembly .....	8-9
Crankshaft, Connecting Rod .....	8-12
Crankshaft Removal .....	8-12
Crankshaft Installation .....	8-12
Crankshaft Disassembly .....	8-13
Crankshaft Assembly .....	8-13
Connecting Rod Big End Seizure Inspection .....	8-14
Connecting Rod Big End Radial Clearance Inspection.....	8-14
Connecting Rod Big End Side Clearance Inspection.....	8-14
Crankshaft Runout Inspection.....	8-14
Crankshaft Alignment Inspection .....	8-15
Starter Motor Clutch .....	8-16
Starter Motor Clutch Removal/Installation .....	8-16
Starter Motor Clutch Disassembly .....	8-16
Starter Motor Clutch Assembly .....	8-16
Starter Motor Clutch Inspection .....	8-16
Starter Motor Idle Gear and Torque Limiter Gear Inspection .....	8-17
External Shift Mechanism.....	8-18
Shift Pedal Removal .....	8-18
Shift Pedal Installation .....	8-18
External Shift Mechanism Removal.....	8-18
External Shift Mechanism Installation .....	8-19
External Shift Mechanism Inspection.....	8-19
Transmission .....	8-20
Transmission Shaft Removal .....	8-20
Transmission Shaft Installation .....	8-20
Transmission Shaft Disassembly .....	8-20
Transmission Shaft Assembly.....	8-21
Shift Drum Removal.....	8-22
Shift Drum Installation.....	8-22
Shift Fork Bending Inspection .....	8-22
Shift Fork Ear/Gear Shift Fork Groove Wear Inspection.....	8-22
Shift Fork Guide Pin/Shift Drum Groove Wear Inspection .....	8-23
Gear Dog/Gear Dog Hole Damage Inspection .....	8-23
Ball Bearing, Needle Bearing, and Oil Seal.....	8-24
Ball and Needle Bearing Wear Inspection .....	8-24
Oil Seal Inspection .....	8-24

# 8-2 CRANKSHAFT/TRANSMISSION

## Exploded View

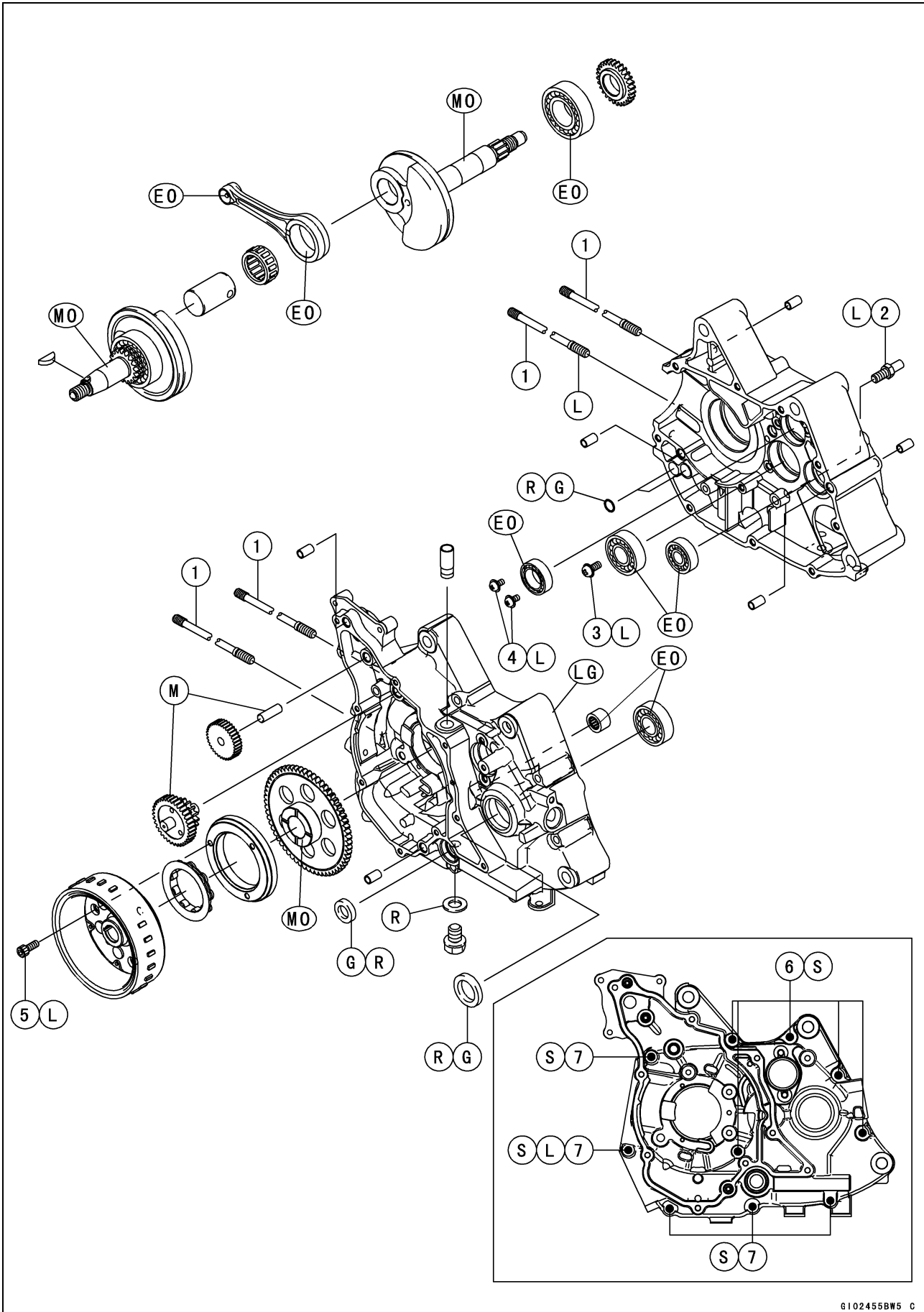



**Exploded View**

No.	Fastener	Torque			Remarks
		N·m	kgf·m	ft·lb	
1	Crankcase Studs	12	1.2	106 in·lb	L (1)
2	Shift Shaft Return Spring Pin	22	2.2	16	L
3	Drive Shaft Bearing Retaining Screw	5.2	0.53	46 in·lb	L
4	Shift Drum Bearing Retaining Screws	2.9	0.30	26 in·lb	L
5	Starter Motor Clutch Bolts	11.8	1.20	104 in·lb	L
6	Crankcase Screws (L = 50 mm)	5.2	0.53	46 in·lb	S
7	Crankcase Screws (L = 75 mm)	5.2	0.53	46 in·lb	L (1), S

EO: Apply engine oil.

G: Apply grease.

L: Apply a non-permanent locking agent.

LG: Apply liquid gasket.

M: Apply molybdenum disulfide grease.

MO: Apply molybdenum disulfide oil solution.

(mixture of engine oil and molybdenum disulfide grease in a weight ratio 10:1)

R: Replacement Parts

S: Follow the specified tightening sequence.

# 8-4 CRANKSHAFT/TRANSMISSION

## Exploded View

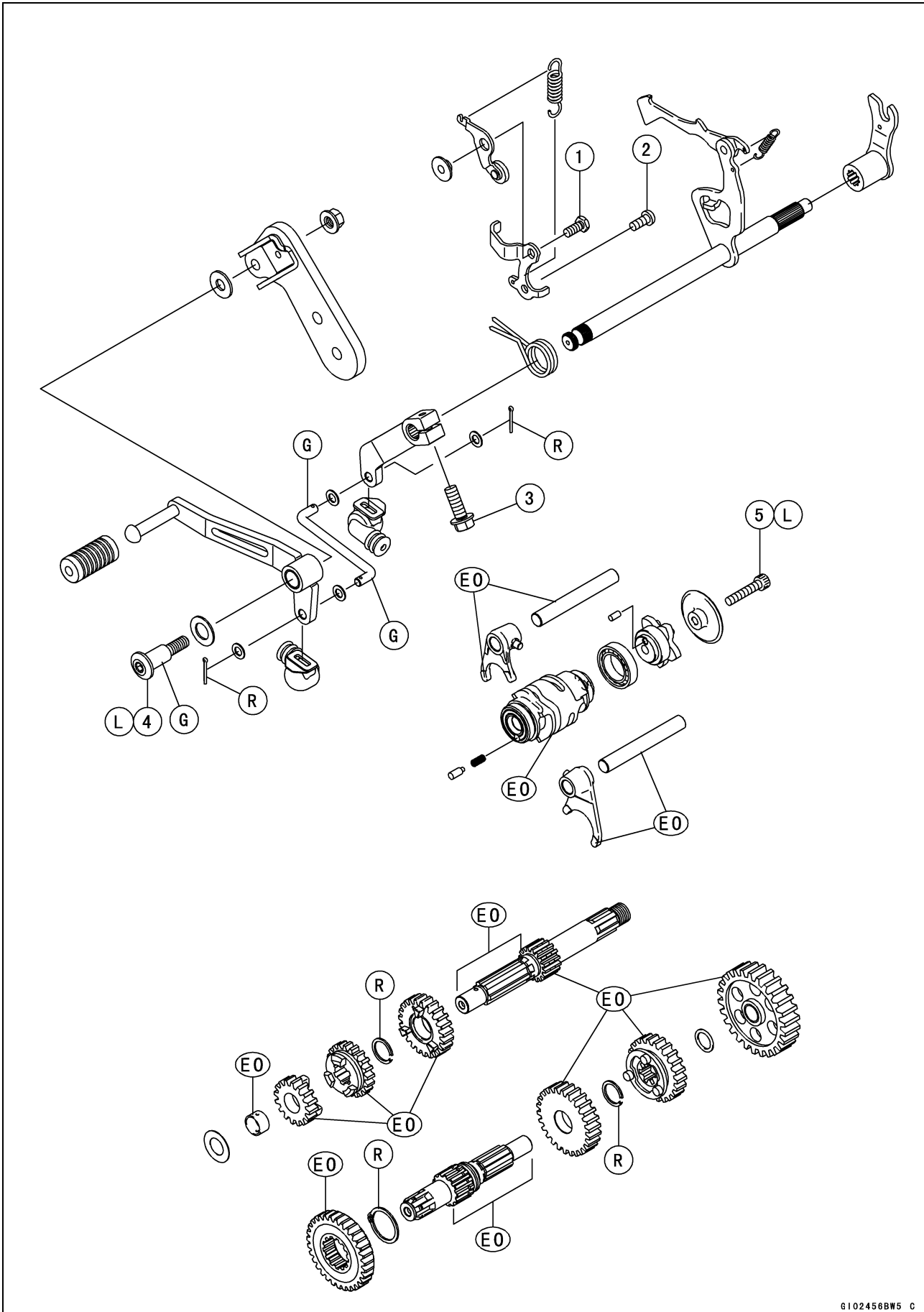

## CRANKSHAFT/TRANSMISSION 8-5

### Exploded View

No.	Fastener	Torque			Remarks
		N·m	kgf·m	ft·lb	
1	Shift Drum Positioning Lever Pivot Bolt	5.2	0.53	46 in·lb	
2	Shift Drum Positioning Plate Screw	5.2	0.53	46 in·lb	
3	Shift Lever Bolt	12	1.2	106 in·lb	
4	Shift Pedal Mounting Bolt	22	2.2	16	G, L
5	Shift Drum Cam Bolt	5.2	0.53	46 in·lb	L

EO: Apply engine oil.

G: Apply grease.

L: Apply a non-permanent locking agent.

R: Replacement Parts

## 8-6 CRANKSHAFT/TRANSMISSION

### Specifications

Item	Standard	Service Limit
<b>Crankshaft, Connecting Rod</b>		
Connecting Rod Big End:		
Radial Clearance	0.006 ~ 0.020 mm (0.00024~ 0.00079 in.)	0.07 mm (0.003 in.)
Side Clearance	0.1 ~ 0.2 mm (0.004 ~ 0.008 in.)	0.4 mm (0.02 in.)
Crankshaft Runout	TIR 0.03 mm (0.0012 in.) or less	TIR 0.08 mm (0.0031 in.)
<b>Transmission</b>		
Shift Fork Ear Thickness	3.9 ~ 4.0 mm (0.154 ~ 0.157 in.)	3.8 mm (0.15 in.)
Gear Groove Width	4.05 ~ 4.15 mm (0.159 ~ 0.163 in.)	4.3 mm (0.17 in.)
Shift Fork Guide Pin Diameter	4.9 ~ 5.0 mm (0.193 ~ 0.197 in.)	4.8 mm (0.19 in.)
Shift Drum Groove Width	5.05 ~ 5.20 mm (0.199 ~ 0.205 in.)	5.3 mm (0.21 in.)

**Special Tools and Sealant**

**Outside Circlip Pliers:**  
**57001-144**

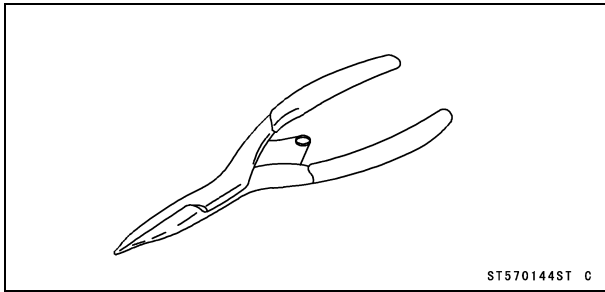

ST570144ST C

**Crankshaft Jig:**  
**57001-1174**

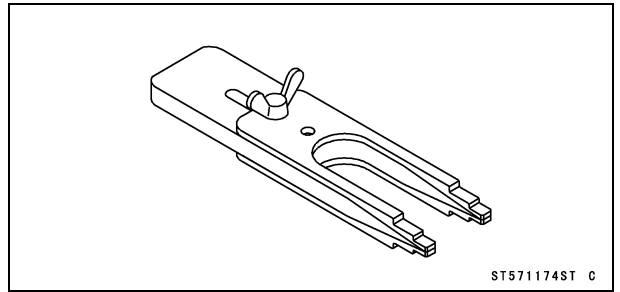

ST571174ST C

**Bearing Puller:**  
**57001-158**

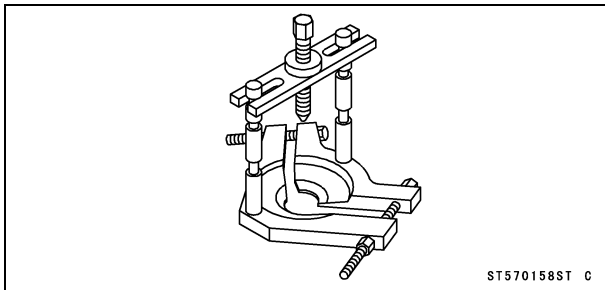

ST570158ST C

**Flywheel Holder:**  
**57001-1313**

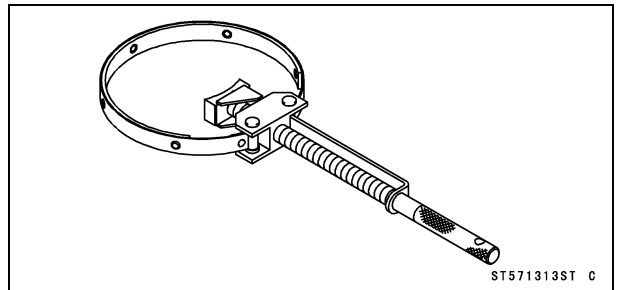

ST571313ST C

**Crankcase Splitting Tool Assembly:**  
**57001-1098**

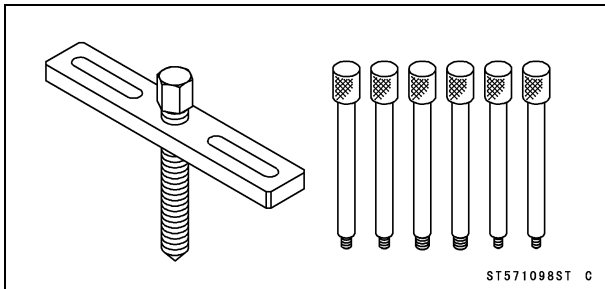

ST571098ST C

**Liquid Gasket, TB1215:**  
**92104-1065**

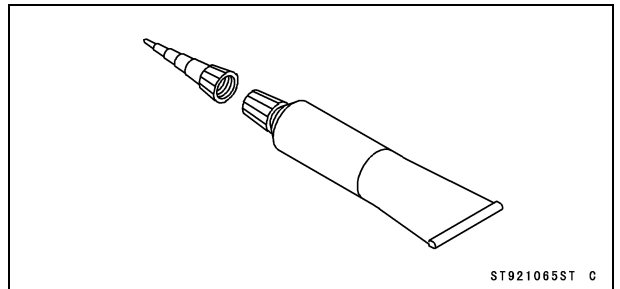

ST921065ST C

**Bearing Driver Set:**  
**57001-1129**

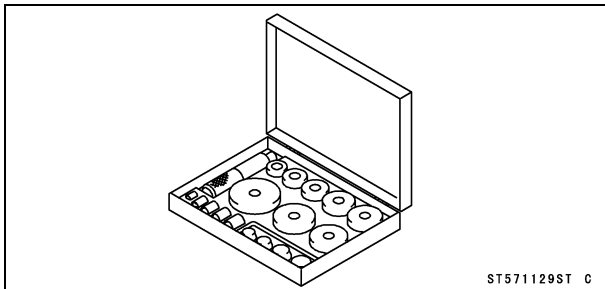

ST571129ST C

○Crankcase Splitting Tool Assembly: 57001-1362 can also be used instead of Crankcase Splitting Tool Assembly: 57001-1098.

## 8-8 CRANKSHAFT/TRANSMISSION

### Crankcase Splitting

#### **Crankcase Splitting**

- Remove the engine (see Engine Removal in the Engine Removal/Installation chapter).
- Set the engine on a clean surface and hold the engine steady while parts are being removed.
- Remove:
  - Cylinder (see Cylinder Removal in the Engine Top End chapter)
  - Camshaft Chain (see Camshaft Chain Removal in the Engine Top End chapter)
  - Piston (see Piston Removal in the Engine Top End chapter)
  - Oil Filter (see Oil Filter Replacement in the Periodic Maintenance chapter)
  - Clutch (see Clutch Removal in the Clutch chapter)
  - External Shift Mechanism (see External Shift Mechanism Removal)
  - Oil Pump (see Oil Pump Removal in the Engine Lubrication System chapter)
  - Gear Position Switch (see Gear Position Switch Removal in the Electrical System chapter)
  - Speed Sensor (see Speed Sensor Removal in the Electrical System chapter)
  - Starter Motor (see Starter Motor Removal in the Electrical System chapter)
  - Starter Motor Idle Gear and Torque Limiter Gear (see Starter Motor Idle Gear and Torque Limiter Gear Inspection)
- Remove:
  - Output Shaft Collar [A]
  - O-ring [B]

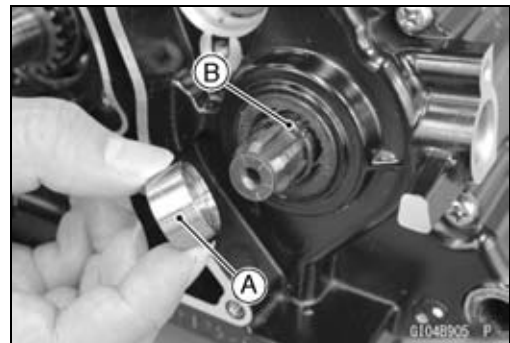

- Remove the crankcase screws [A].

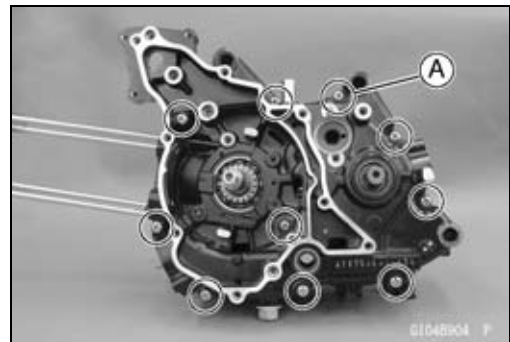

## Crankcase Splitting

- Position the connecting rod in BDC.
- Insert the crankshaft jig [A] between the crankshaft flywheels opposite the connecting rod big end to protect flywheel alignment. This tool is easily adjustable to fit in any gap between the flywheel.

**Special Tool - Crankshaft Jig: 57001-1174**

- Using the crankcase splitting tool assembly [B], split the crankcase.

**Special Tool - Crankcase Splitting Tool Assembly: 57001-1098**  
**or Crankcase Splitting Tool Assembly: 57001-1362**

- Once the crankcase is split, remove the crankcase splitting tool and crankshaft jig. Separate the crankcase halves.

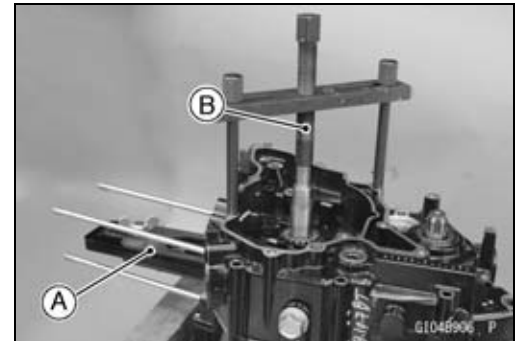

## Crankcase Assembly

### NOTICE

**Right and left crankcase halves are machined at the factory in the assembled state, so the crankcase halves must be replaced as a set.**

- Chip off the old gasket from the mating surfaces of the crankcase halves.
- Blow on compressed air to the oil passages [A] in the crankcase halves and the crankshaft.
- With high flash-point solvent, clean off the mating surfaces of the crankcase halves and wipe dry.



### ⚠ WARNING

**Gasoline and low flash-point solvents can be flammable and/or explosive and cause severe burns. Clean the engine parts in a well-ventilated area, and take care that there is no spark or flame anywhere near the working areas. Do not use gasoline or low flash-point solvents to clean parts.**

- Using a press and the bearing driver set, install new bearings until they bottoms out.

**Special Tool - Bearing Driver Set: 57001-1129**

- Press in the oil seals of the left crankcase half so that the seal surface is flush [A] with the end of the hole.
- Apply grease to the oil seal lips.

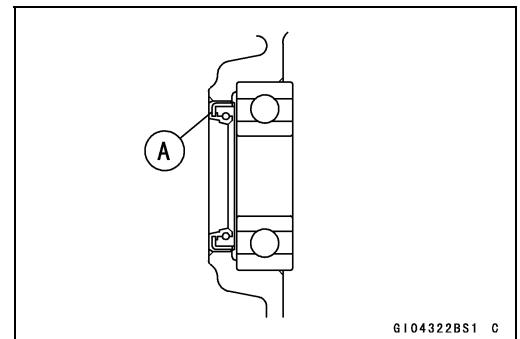

## 8-10 CRANKSHAFT/TRANSMISSION

### Crankcase Splitting

- Apply a non-permanent locking agent to the bearing retaining screws.
- Tighten the shift drum bearing retaining screws [A] and drive shaft bearing retaining screw [B] to the right crankcase.

**Torque - Shift Drum Bearing Retaining Screws: 2.9 N·m (0.30 kgf·m, 26 in·lb)**

**Drive Shaft Bearing Retaining Screw: 5.2 N·m (0.53 kgf·m, 46 in·lb)**

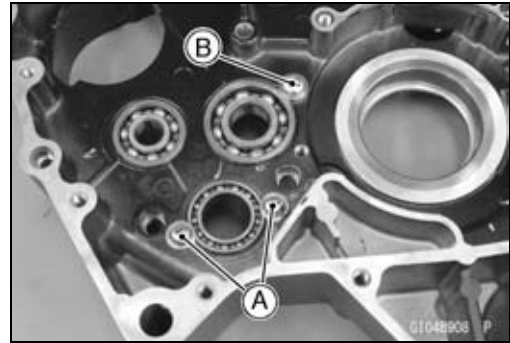

- Install:
  - Shift Drum (see Shift Drum Installation)
  - Crankshaft (see Crankshaft Installation)
  - Transmission Shafts (see Transmission Shaft Installation)

- Make sure that the mating surfaces of the crankcase halves are completely free of oil or contamination.
- Using a high flash-point solvent, clean off any oil or dirt that may be on the liquid gasket coating area. Dry them with a clean cloth.
- Apply liquid gasket to the mating surface of the left crankcase half as shown.

**Sealant - Liquid Gasket, TB1215: 92104-1065**

#### NOTE

○Do not apply liquid gasket to this area [A].

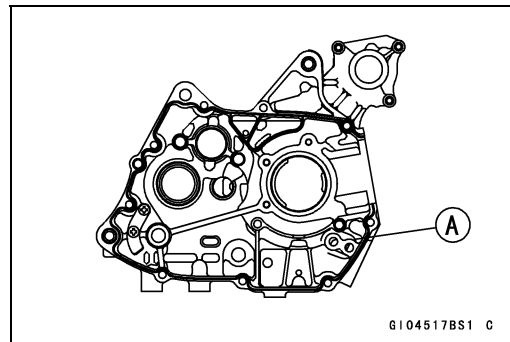

- Replace the O-rings [A] with new ones.
- Apply grease to the O-rings, and install them.
- Check that the dowel pins [B], the O-rings and the drive shaft spacer [C] are in place of the right crankcase half.

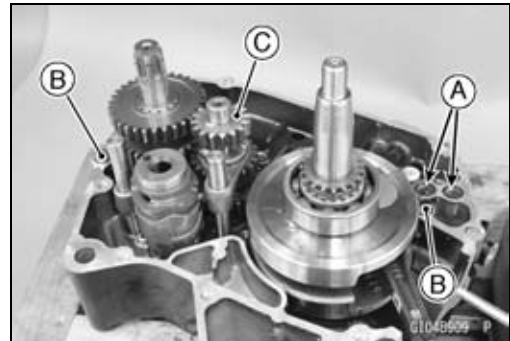

- Turn the crankshaft to BDC, and install the crankshaft jig between the flywheels opposite the connecting rod big end to protect flywheel alignment.

**Special Tool - Crankshaft Jig: 57001-1174**

- Fit the crankcase halves together hitting with a plastic mallet on the left crankcase side.
- Tighten the crankcase screws in that order shown.

**Torque - Crankcase Screws: 5.2 N·m (0.53 kgf·m, 46 in·lb)**

#### NOTE

○Apply a non-permanent locking agent to this screw [10] only.

- Remove the crankshaft jig.

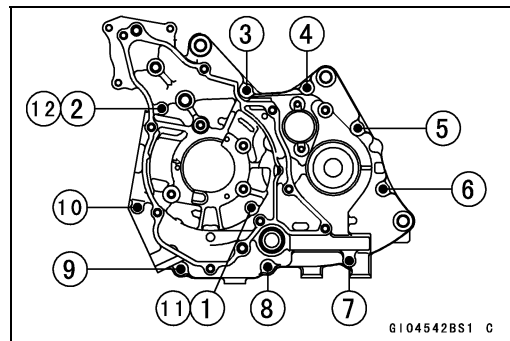



## Crankcase Splitting

- Replace the O-ring [A] with a new one.
- Apply grease to the new O-ring.
- Install the collar [B] to the output shaft.
- Turn the stepped side [C] of the collar to inside.

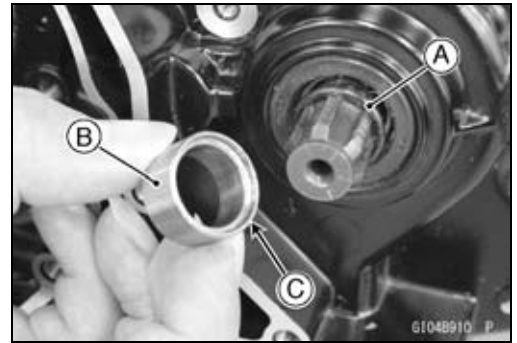

- Check to see that the crankshaft, and the output shaft all turn freely.
- ★ If the crankshaft will not turn, it is probably not centered. Tap the mount portion of the crankcase with a plastic mallet [A] to reposition it. If it does not free up, split the crankcase again and find the cause.
- ★ Spinning the output shaft, shift the transmission through all the gears to make certain there is not binding and that all the gears shift properly.

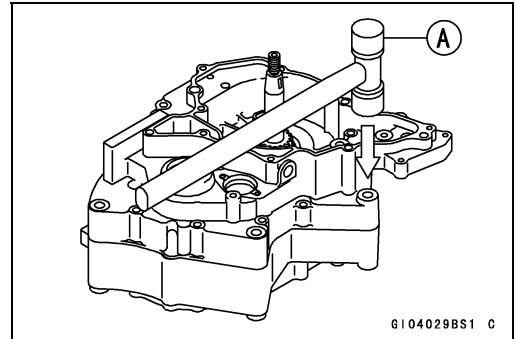

## 8-12 CRANKSHAFT/TRANSMISSION

### Crankshaft, Connecting Rod

#### **Crankshaft Removal**

- Split the crankcase (see Crankcase Splitting).
- Remove:
  - Transmission Shafts [A] (see Transmission Shaft Removal)
  - Shift Drum [B] (see Shift Drum Removal)

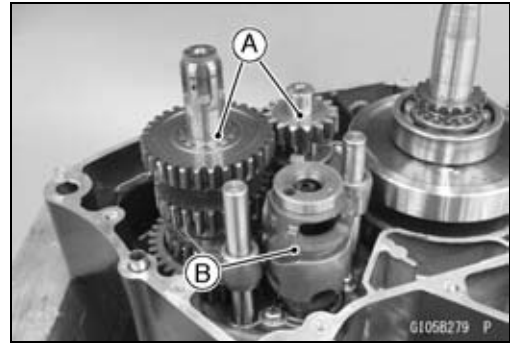

- Using a press [A], remove the crankshaft [B] from the right crankcase half [C].

#### **NOTICE**

**Do not remove the ball/needle bearings and the oil seals unless it is necessary. Removal may damage them.**

- ★ If the bearing remains on the crankcase half, then push out it.

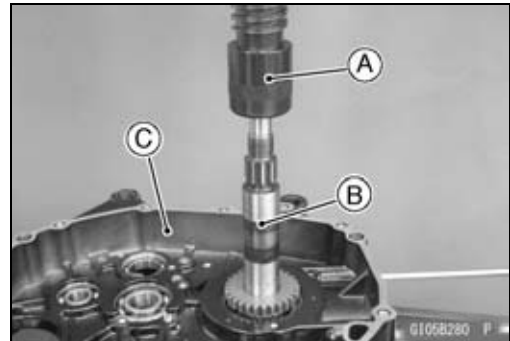

#### **Crankshaft Installation**

- Insert the crankshaft jig [A] between the crankshaft flywheels opposite the connecting rod big end to protect flywheel alignment.

**Special Tool - Crankshaft Jig: 57001-1174**

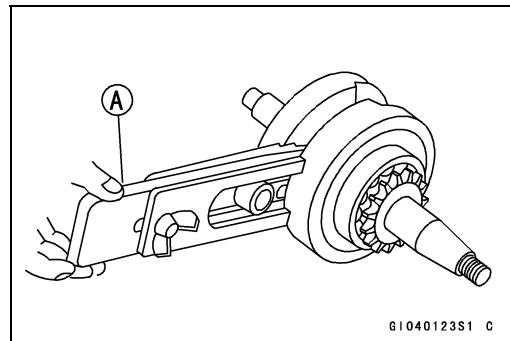

- Turn the connecting rod to BDC, and install the crankshaft to the right crankcase together with the crankshaft jig [A].
  - Using a press [B], install the crankshaft [C] into the right crankcase.
- When pressing, position the jig in the crankcase opening so that the jig will not hit the crankcase.

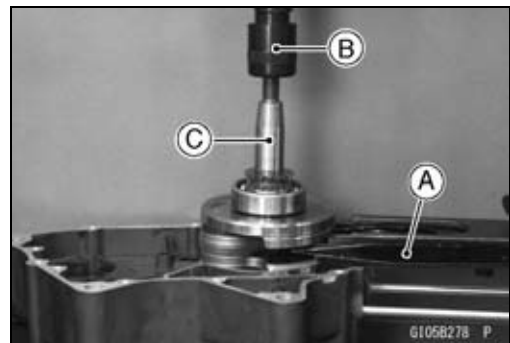

Crankshaft, Connecting Rod

**Crankshaft Disassembly**

**NOTICE**

Since assembly of the crankshaft demands exacting tolerance, the disassembly and reassembly of the crankshaft should only be performed by experienced mechanics with the necessary tools and equipment. The crankpin, connecting rod, and light crankshaft are available separately as spare parts, however it is recommended that the crankshaft assembly be replaced rather than attempting to replace the components.

- ★ If it should be necessary to disassemble the crankshaft, follow the following procedures.
- Remove the oil pump drive gear and bearing, using the bearing puller.
- Special Tool - Bearing Puller: 57001-158**
- Remove the crankpin with a press.
- Removal of the crankpin separates the flywheels, the connecting rod, the big end needle bearing and the crankpin.

**Crankshaft Assembly**

- Carefully align the oil passage hole in the right flywheel [A] with the one in the crankpin [B] at rebuilding of the crankshaft as shown.
- Using compressed air, check that the air goes through the oil passage hole.

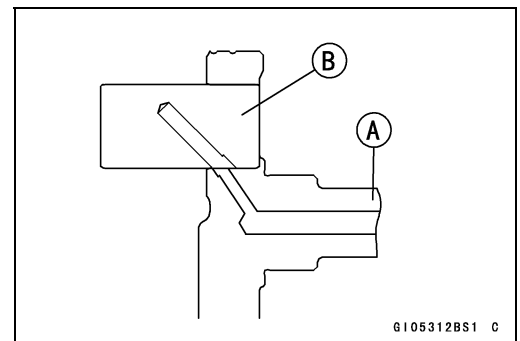

- Apply engine oil to the big end bearing.
- Press the crank halves onto the crankpin, noting the crankpin direction until connecting rod side clearance is within specification as shown.  
 Side Clearance [A]: 0.1 ~ 0.2 mm (0.004 ~ 0.008 in.)  
 Crankpin Depth [B]: 0.8 ~ 1.2 mm (0.031 ~ 0.047 in.)

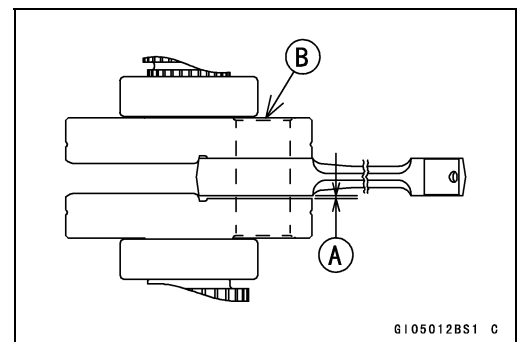

- Press the bearing [A] and oil pump drive gear [B] until it bottoms out.
- Check the following items after assemble the crankshaft.  
 Connecting Rod Radial Clearance (see Connecting Rod Big End Radial Clearance Inspection)  
 Connecting Rod Side Clearance (see Connecting Rod Big End Side Clearance Inspection)  
 Crankshaft Runout (see Crankshaft Runout Inspection)

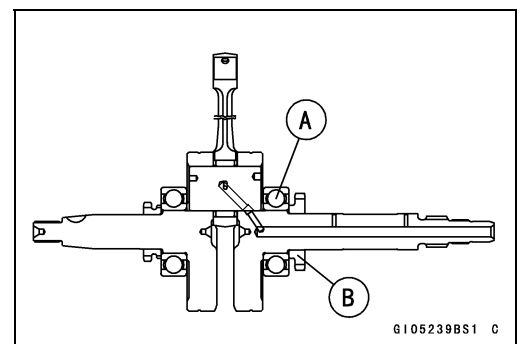

## 8-14 CRANKSHAFT/TRANSMISSION

### Crankshaft, Connecting Rod

#### Connecting Rod Big End Seizure Inspection

- ★ In the case of serious seizure with damaged flywheels, the crankshaft must be replaced.
- ★ In the case of less serious damage, disassemble the crankshaft and replace the crankpin, the needle bearing, and the connecting rod.

#### Connecting Rod Big End Radial Clearance Inspection

- Set the crankshaft in flywheel alignment jig or on V blocks, and place a dial gauge [A] against the big end of the connecting rod.
- Push [B] the connecting rod first towards the gauge and then in the opposite direction. The difference between the two gauge readings is the radial clearance.
- ★ If the radial clearance exceeds the service limit, the crankshaft should be either replaced or disassembled and the crankpin, the needle bearing, and the connecting rod big end examined for wear.

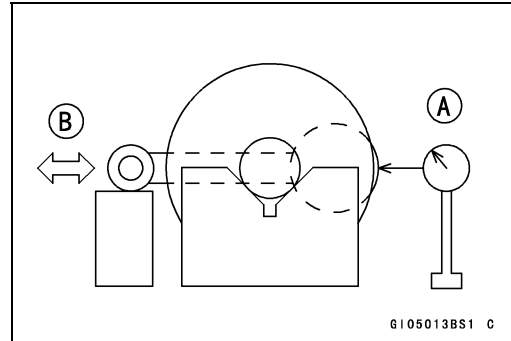

#### Connecting Rod Big End Radial Clearance

Standard: 0.006 ~ 0.020 mm (0.00024 ~ 0.00079 in.)

Service Limit: 0.07 mm (0.003 in.)

#### Connecting Rod Big End Side Clearance Inspection

- Measure the side clearance [A] of the connecting rod with a thickness gauge.
- ★ If the clearance exceeds the service limit, replace the crankshaft.

#### Connecting Rod Big End Side Clearance

Standard: 0.1 ~ 0.2 mm (0.004 ~ 0.008 in.)

Service Limit: 0.4 mm (0.02 in.)

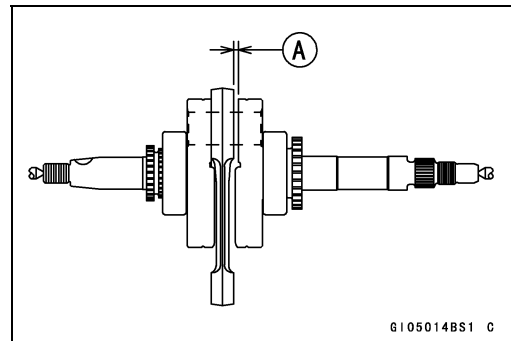

#### Crankshaft Runout Inspection

- Set the crankshaft in a flywheel alignment jig or on V blocks, and place a dial gauge [A] against the points indicated.  
Measurement Point: 8 mm (0.3 in.) [B]
- Turn the crankshaft slowly. The maximum difference in gauge readings is the crankshaft runout.

#### Crankshaft Runout

Standard: TIR 0.03 mm (0.0012 in.) or less

Service Limit: TIR 0.08 mm (0.0031 in.)

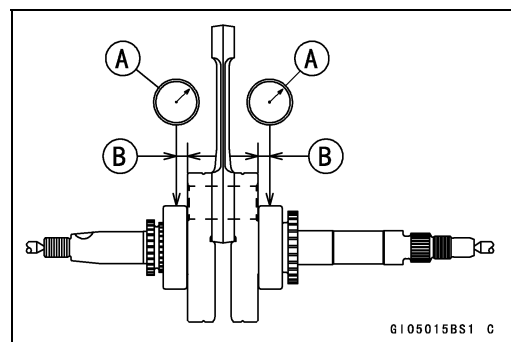

**Crankshaft, Connecting Rod**

**Crankshaft Alignment Inspection**

- ★ If the runout at either point exceeds the service limit, align the flywheels so that the runout falls within the service limit.
- In the case of horizontal misalignment, which is the most common, strike the projecting rim of the flywheel with a plastic, soft lead, or brass hammer as shown.
- Recheck the runout with a dial gauge, repeating the process until the runout falls within the service limit.
- Vertical misalignment is corrected either by driving a wedge in between the flywheels, or by squeezing the flywheel rims in a vise, depending on the nature of the misalignment.
- In the case of both horizontal and vertical misalignment, correct the horizontal misalignment first.
- Recheck big end side clearance after aligning crankshaft (see Connecting Rod Big End Side Clearance Inspection).

**NOTE**

○ If crankshaft alignment cannot be corrected by the above method, replace the crankpin or crank halves as required. Recheck the runout and repeat the process until the runout is within service limit.

**NOTICE**

**Don't hammer the flywheel at the point [A].**

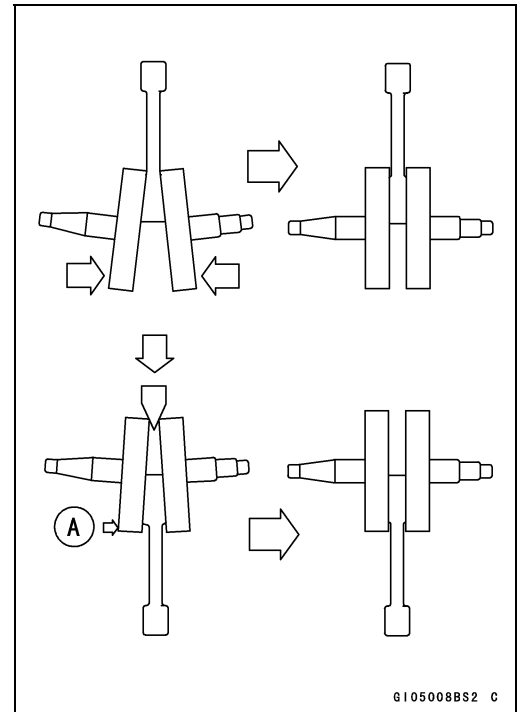
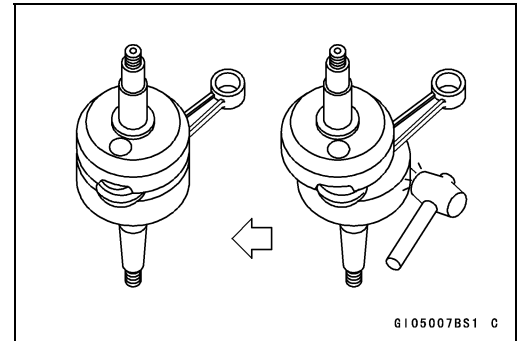

## 8-16 CRANKSHAFT/TRANSMISSION

### Starter Motor Clutch

#### Starter Motor Clutch Removal/Installation

- Refer to the Starter Motor Clutch Disassembly/Assembly.

#### Starter Motor Clutch Disassembly

- Remove the alternator rotor (see Alternator Rotor Removal in the Electrical System chapter).
- Hold the alternator rotor with the flywheel holder (see Alternator Rotor Removal in the Electrical System chapter).

**Special Tool - Flywheel Holder: 57001-1313**

- Remove:
  - Starter Motor Clutch Bolts [A]
  - Starter Motor Clutch
- Separate the one-way clutch and race.

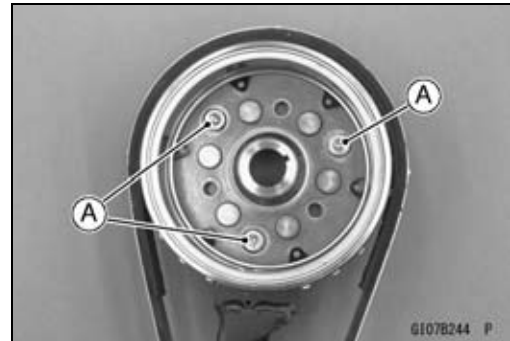

#### Starter Motor Clutch Assembly

- Install the one-way clutch [A] into the race [B].
- Install the starter motor clutch so that its stepped side [C] fits the alternator rotor.
- Apply a non-permanent locking agent to the starter motor clutch bolts [D].

**Torque - Starter Motor Clutch Bolts: 11.8 N·m (1.20 kgf·m, 104 in·lb)**

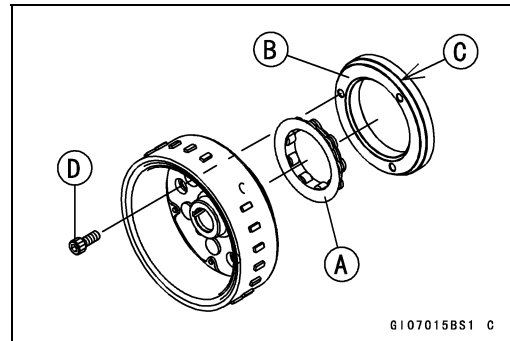

#### Starter Motor Clutch Inspection

- Remove the alternator cover (see Alternator Cover Removal in the Electrical System chapter).
- Remove the shaft [A] and starter motor idle gear [B].

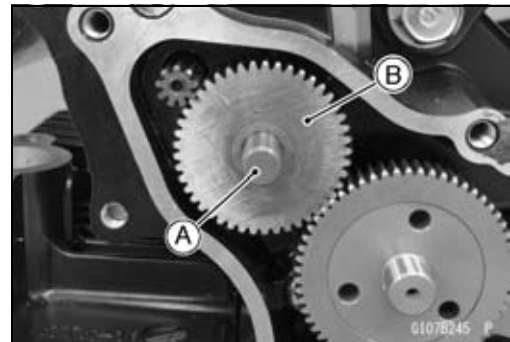

- Turn the torque limiter gear [A], then the starter motor clutch gear [B] should turn clockwise [C] freely but should not turn counterclockwise.
- ★ If the starter motor clutch does not operate as it should or if it makes noise, go to the next step.
- Disassemble the starter motor clutch, and visually inspect the clutch parts.
- ★ If there is any worn or damaged part, replace it.

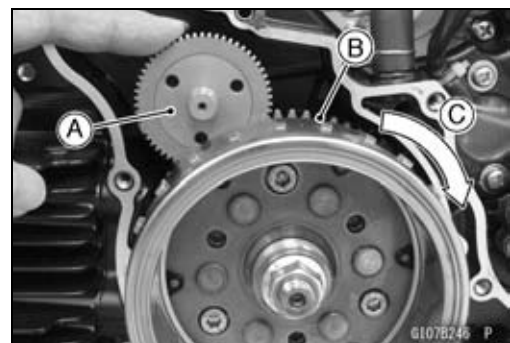

## Starter Motor Clutch

- Remove the alternator rotor (see Alternator Rotor Removal in the Electrical System chapter).
- Remove the torque limiter gear.
- Inspect the starter motor clutch gear [A].
- ★ If the sliding surface [B] is worn or damaged, replace the starter motor clutch gear.

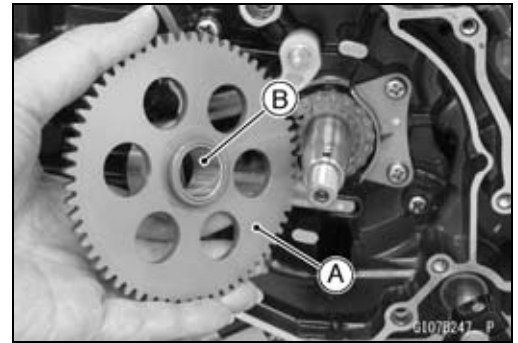

## Starter Motor Idle Gear and Torque Limiter Gear Inspection

- Remove:
  - Alternator Rotor (see Alternator Rotor Removal in the Electrical System chapter)
  - Starter Motor Idle Gear [A]
  - Torque Limiter Gear [B]
- Visually inspect the gears.
- ★ If the gear has wear, discoloration, or other damage, replace it.

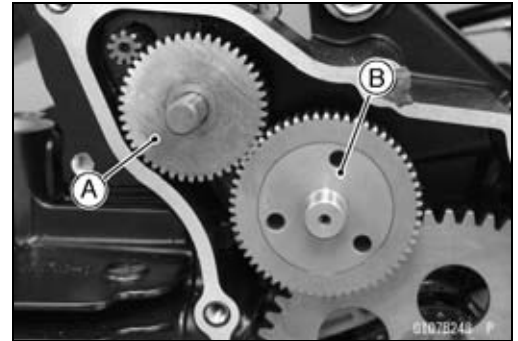

## 8-18 CRANKSHAFT/TRANSMISSION

### External Shift Mechanism

#### Shift Pedal Removal

- Remove:
  - Shift Lever Bolt [A]
  - Shift Lever [B]
  - Shift Pedal Bolt [C]
  - Washers
  - Shift Pedal [D] with Tie-Rod [E]

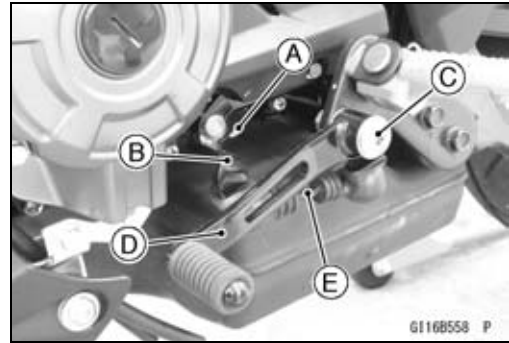

#### Shift Pedal Installation

- Install the shift lever [A] to the shift shaft [B].
- Align the slit [C] of shift lever with mark [D] on engine sprocket cover.
- Tighten the shift lever bolt [E].
- Torque - Shift Lever Bolt: 12 N·m (1.2 kgf·m, 106 in·lb)**

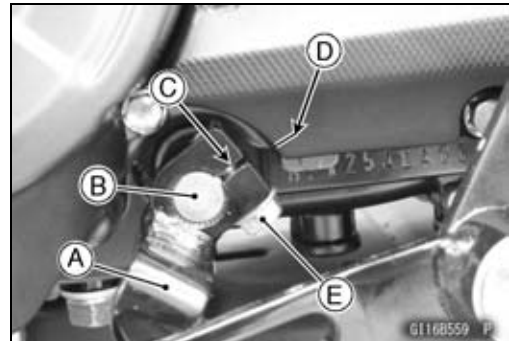

- Apply grease to the sliding surface of the shift pedal mounting bolt [A].
- Install:
  - Washers [B]
  - Shift Pedal [C] with Tie-Rod
- Apply a non-permanent locking agent to the shift pedal mounting bolt.
- Tighten:
  - Torque - Shift Pedal Mounting Bolt: 22 N·m (2.2 kgf·m, 16 ft·lb)**

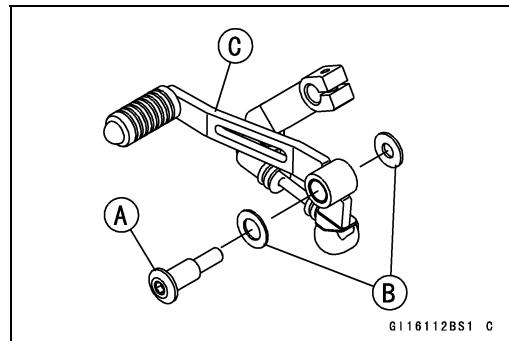

- Be sure that the shift pedal [A] is within the lines the step lower surface position as shown.
  - Center of Alternator Cover Bolt [B]
  - Front Step Lower Surface [C]
  - 10 mm (0.39 in.) [D]
  - Tolerance  $\pm 5$  mm ( $\pm 0.2$  in.) [E]

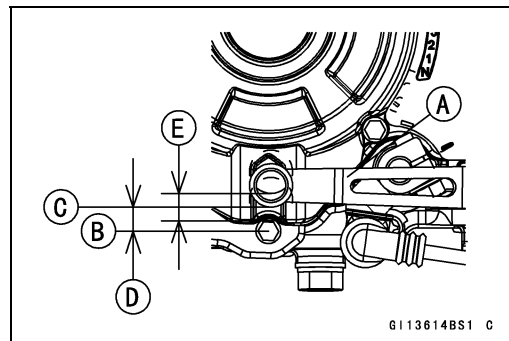

#### External Shift Mechanism Removal

- Remove:
  - Shift Pedal (see Shift Pedal Removal)
  - Clutch (see Clutch Removal in the Clutch chapter)
- Move the shift mechanism arm [A] out of its position the end of the shift drum and pull out the shift shaft [B].

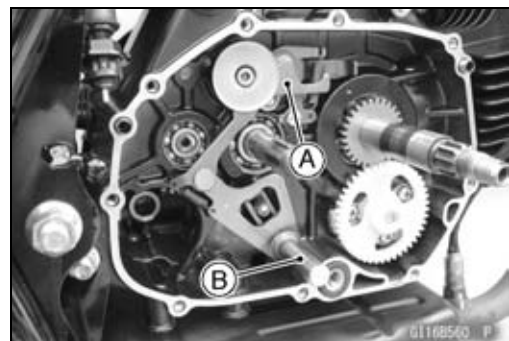



## External Shift Mechanism

- Remove the screw [A] and the pivot bolt [B].
- Remove the shift drum positioning plate [C], lever [D] and its spring [E] as a set.

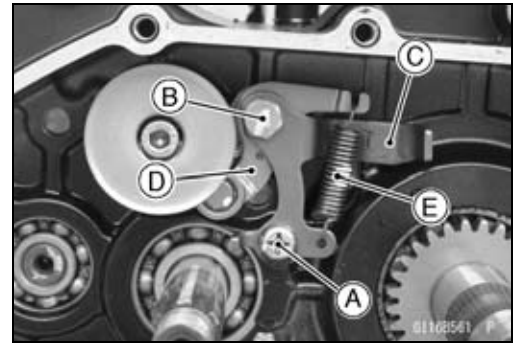

### External Shift Mechanism Installation

- Install the shift drum positioning lever [A], plate [B] and spring [C].
- Tighten:
  - Torque - Shift Drum Positioning Lever Pivot Bolt [D]: 5.2 N·m (0.53 kgf·m, 46 in·lb)
  - Shift Drum Positioning Plate Screw [E]: 5.2 N·m (0.53 kgf·m, 46 in·lb)

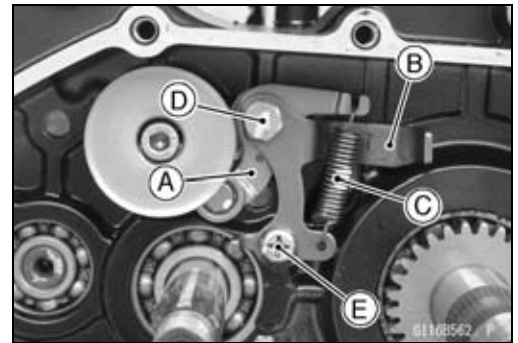

- Check that the return spring pin [A] is not loosening.
- ★ If it is loose, unscrew it, apply a non-permanent locking agent to the threads, and tighten it.

Torque - Shift Shaft Return Spring Pin: 22 N·m (2.2 kgf·m, 16 ft·lb)

- Insert the shift shaft [B].
- Check that the return spring [C] and the shift arm spring [D] are properly fitted on the mechanism.

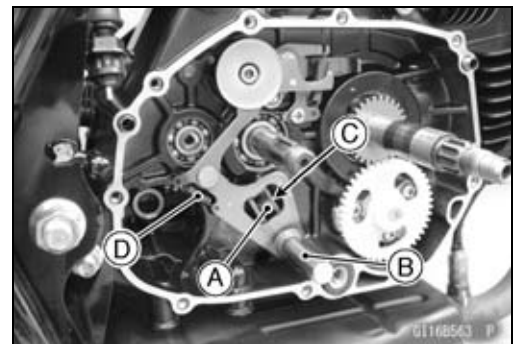

### External Shift Mechanism Inspection

- Visually inspect the shift shaft for any damage.
- ★ If the shaft [A] is bent, straighten or replace it.
- ★ If the splines [B] are damaged, replace the shaft.
- ★ If the return spring [C] and arm spring [D] are damaged in any way, replace them.
- ★ If the shift pawl [E] is damaged in any way, replace the shift shaft assembly.

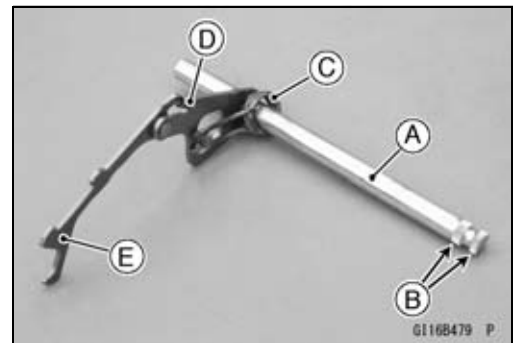

- Check the shift drum positioning lever [A] and spring [B] for breaks or distortion.
- ★ If the lever or spring are damaged in any way, replace them.

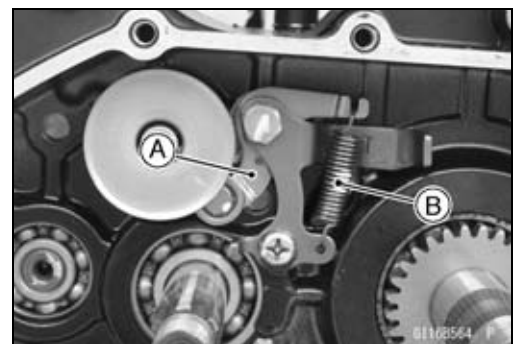

## 8-20 CRANKSHAFT/TRANSMISSION

### Transmission

#### **Transmission Shaft Removal**

- Split the crankcase (see Crankcase Splitting).
- Remove the shift rods [A] and shift forks [B].
- Remove the drive [C] and output [D] shaft assemblies as a set.

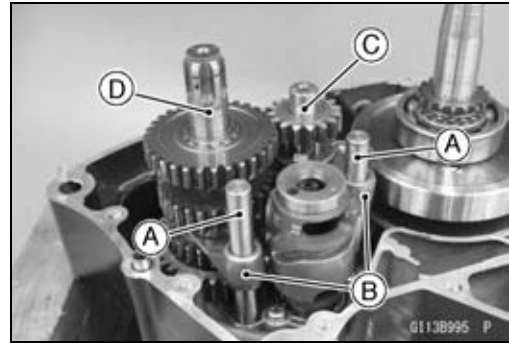

#### **Transmission Shaft Installation**

- Apply engine oil to the transmission gears, bearings, and shaft journal.
- Fit the output [A] and drive [B] shaft assemblies as a set into the right crankcase half.
- Set the shift drum in neutral position.

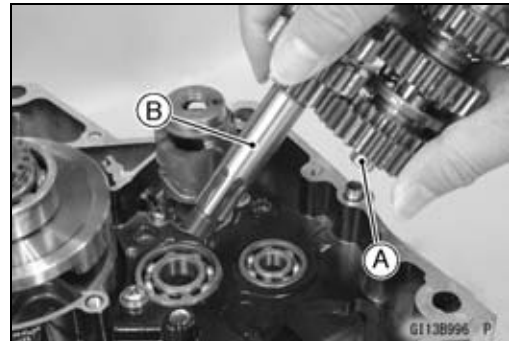

- Apply engine oil to the shift fork ears and the shift drum groove.
- Fit each shift fork into its gear groove so that the shift fork guide pin is in the proper shift drum groove.

#### **NOTE**

○Fingers of the 1st/3rd shift fork are longer than the fingers of the 2nd/4th shift fork.

- Apply engine oil to the shift rods [A], and insert each rod running it through each shift fork [B].
- Set the shift drum in neutral position, that is, the drive and output shaft turn freely.
- Assemble the crankcase (see Crankcase Assembly).

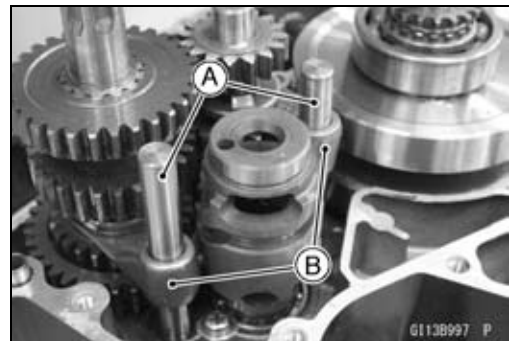

#### **NOTE**

○For BR125G model, shall be checked that it is impossible to shift change from top position to neutral position when rear wheel is driven.

#### **Transmission Shaft Disassembly**

- Remove the drive and output shafts (see Transmission Shaft Removal).
- Using the circlip pliers to remove the circlip, disassemble the transmission shaft and gears.

**Special Tool - Outside Circlip Pliers: 57001-144**

Transmission

**Transmission Shaft Assembly**

● Assemble the transmission gears with following procedures.

- Replace the old circlip with a new one.
- The drive shaft gears can be identified by size; the smallest diameter gear is 1st gear, and the largest it 4th. Be sure that all parts are put back in the correct sequence, facing the proper direction, and that the circlip and the washer are properly in place.

- 2nd Gear [A]
- 3rd Gear [B]
- 4th Gear [C]
- 1st Gear [D]
- Circlip [E]
- Spacer [F]
- Bushing [G]

- Apply engine oil to the step, spline portion [A] and outside of bushing [B] on the drive shaft.

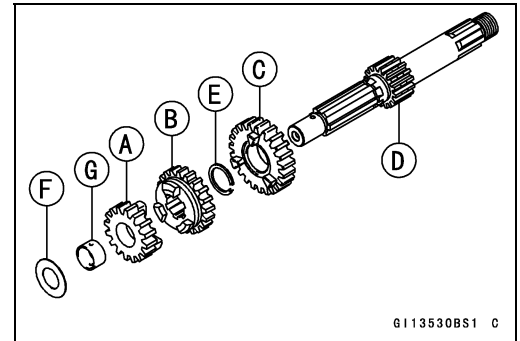

G113530BS1 C

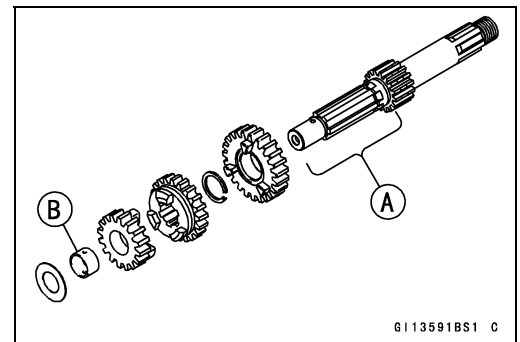

G113591BS1 C

- The output shaft gears can be identified by size; the largest diameter gear is 1st gear, and the smallest is 4th. Be sure that all parts are put back in the correct sequence and facing the proper direction, and that the circlip is properly in place.

- 2nd Gear [A]
- 3rd Gear [B]
- 4th Gear [C]
- 1st Gear [D]
- Circlip [E]
- Spacer [F]
- Circlip [G]
- Output Shaft [H]

- Apply engine oil to the step and spline portion [A] on the output shaft.

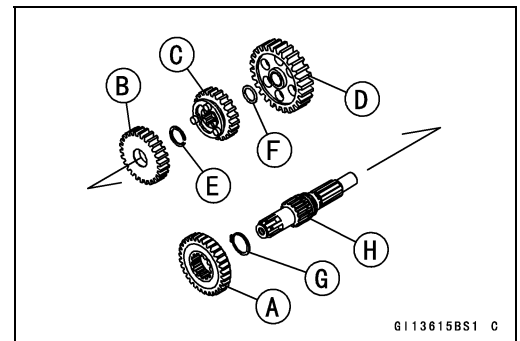

G113615BS1 C

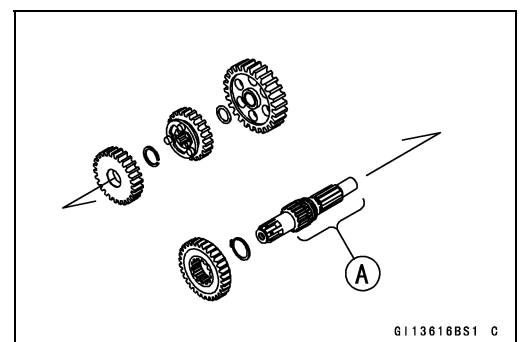

G113616BS1 C

## 8-22 CRANKSHAFT/TRANSMISSION

### Transmission

○Always install circlips so that the opening is aligned with a spline groove. To install a circlip without damage, first fit the circlip onto the shaft expanding it just enough to install it, and then use a suitable gear to push the circlip into place.

Opening of Circlip [A]

Groove of Shaft Spline [B]

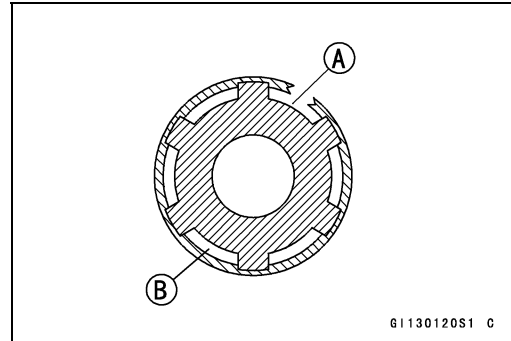

### Shift Drum Removal

- Remove the shift forks and transmission shafts (see Transmission Shaft Removal).
- While holding the shift drum by inserting a suitable bar into the drum, remove the shift drum cam bolt [A].
- Remove:
  - Cam holder [B]
  - Shift Drum Cam [C]
  - Dowel Pin
  - Shift Drum

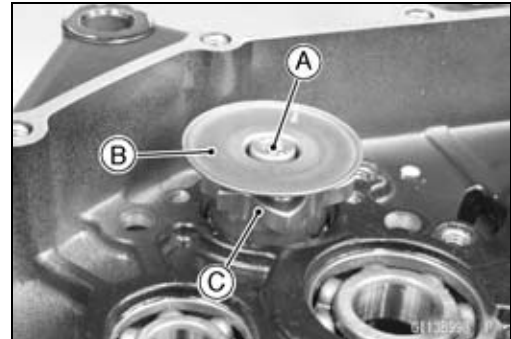

### Shift Drum Installation

- Fit the shift drum to the right crankcase half.
  - Install the shift drum cam [A] aligning its hole [B] with the dowel pin [C].
  - Apply a non-permanent locking agent to the shift drum cam bolt.
  - Install the cam holder and tighten the shift drum cam bolt.
- Torque - Shift Drum Cam Bolt: 5.2 N·m (0.53 kgf·m, 46 in·lb)**

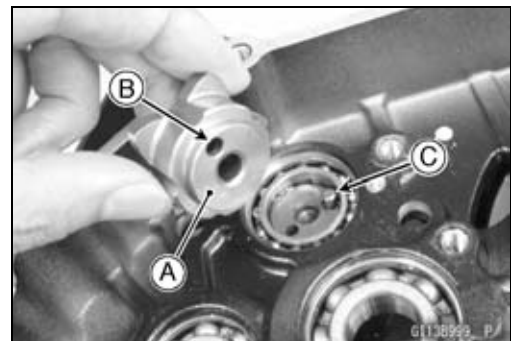

### Shift Fork Bending Inspection

- Visually inspect the shift forks, and replace any fork that is bent. A bent fork could cause difficulty in shifting, or allow the transmission to jump out of gear when under power. 90° [A]

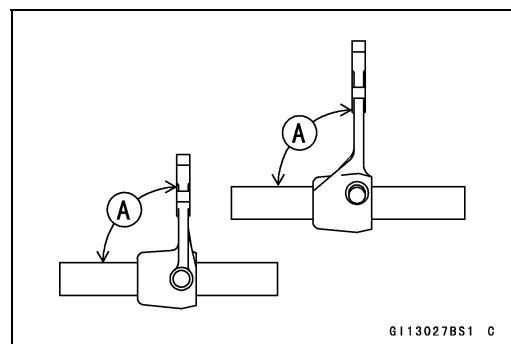

### Shift Fork Ear/Gear Shift Fork Groove Wear Inspection

- Measure the thickness [A] of the shift fork ears.
- ★ If the thickness of shift fork ear is less than the service limit, the shift fork must be replaced.

#### Shift Fork Ear Thickness

**Standard: 3.9 ~ 4.0 mm (0.154 ~ 0.157 in.)**

**Service Limit: 3.8 mm (0.15 in.)**

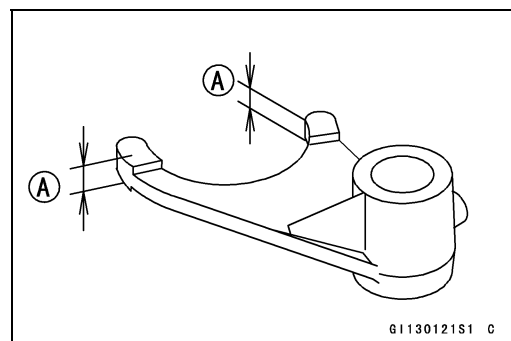

**Transmission**

- Measure the width [A] of the gear shift fork groove in the transmission gears.
- ★ If a gear shift fork groove is worn over the service limit, the gear must be replaced.

**Gear Groove Width**

**Standard:** 4.05 ~ 4.15 mm (0.159 ~ 0.163 in.)

**Service Limit:** 4.3 mm (0.17 in.)

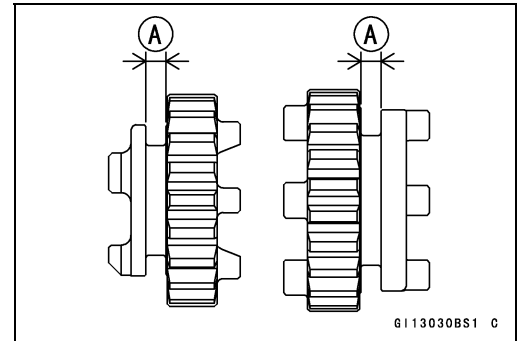

**Shift Fork Guide Pin/Shift Drum Groove Wear Inspection**

- Measure the diameter [A] of each shift fork guide pin, and measure the width of each shift drum groove.
- ★ If the guide pin on any shift fork is less than the service limit, the fork must be replaced.

**Shift Fork Guide Pin Diameter**

**Standard:** 4.9 ~ 5.0 mm (0.193 ~ 0.197 in.)

**Service Limit:** 4.8 mm (0.19 in.)

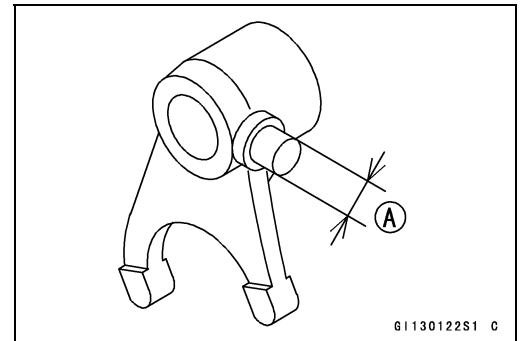

- ★ If any shift drum groove [A] is worn over the service limit, the drum must be replaced.

**Shift Drum Groove Width**

**Standard:** 5.05 ~ 5.20 mm (0.199 ~ 0.205 in.)

**Service Limit:** 5.3 mm (0.21 in.)

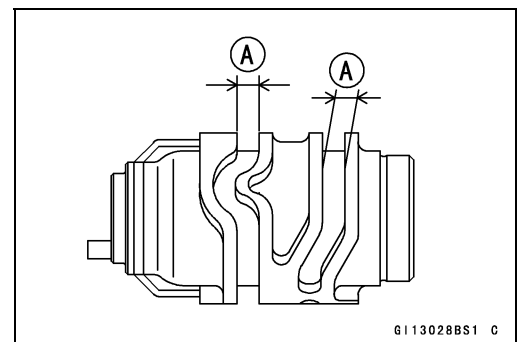

**Gear Dog/Gear Dog Hole Damage Inspection**

- Visually inspect the gear dogs [A] and gear dog holes [B].
- ★ Replace any damaged gears or gears with excessively worn dogs or dog holes.

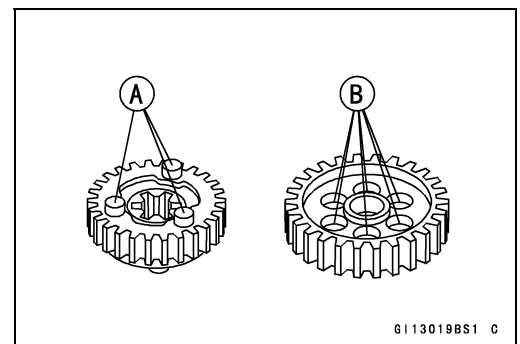

## 8-24 CRANKSHAFT/TRANSMISSION

### Ball Bearing, Needle Bearing, and Oil Seal

#### *Ball and Needle Bearing Wear Inspection*

##### **NOTICE**

**Do not remove the ball bearings for inspection. Removal may damage them.**

- Check the ball bearings.
  - Since the ball bearings are made to extremely close tolerances, the wear must be judged by feel rather than measurement. Clean each bearing in high flash-point solvent, dry it (do not spin the bearing while it is dry), and oil it with engine oil.
  - Turn [A] each bearing over by hand and see that it makes no noise, turns smoothly and has no rough spots.
  - ★ If any of the bearings are defective, replace them.
- Check the needle bearings.
  - The rollers in a needle bearing normally wear very little, and wear is difficult to measure. Instead of measuring, inspect the bearing for abrasion, color change, or other damage.
  - ★ If there is any doubt as to the condition of a needle bearing, replace it.

#### ***Oil Seal Inspection***

- Inspect the oil seal.
- ★ Replace it if the lips are misshapen, discolored (indicating that the rubber has deteriorated), hardened or otherwise damaged.

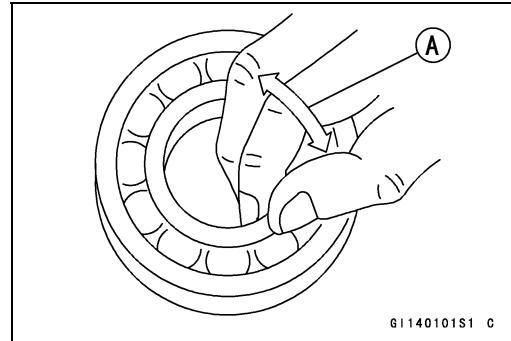

# Wheels/Tires

## Table of Contents

Exploded View .....	9-2
Specifications .....	9-4
Special Tools .....	9-5
Wheels (Rims) .....	9-6
Front Wheel Removal .....	9-6
Front Wheel Installation .....	9-6
Rear Wheel Removal .....	9-7
Rear Wheel Installation .....	9-8
Wheel Inspection .....	9-9
Axle Inspection .....	9-10
Tires .....	9-11
Air Pressure Inspection/Adjustment .....	9-11
Tire Inspection .....	9-11
Tire Removal .....	9-11
Tire Installation .....	9-11
Tire Repair .....	9-13
Hub Bearing .....	9-14
Hub Bearing Removal .....	9-14
Hub Bearing Installation .....	9-14
Hub Bearing Inspection .....	9-15
Hub Bearing Lubrication .....	9-15

# 9-2 WHEELS/TIRES

## Exploded View

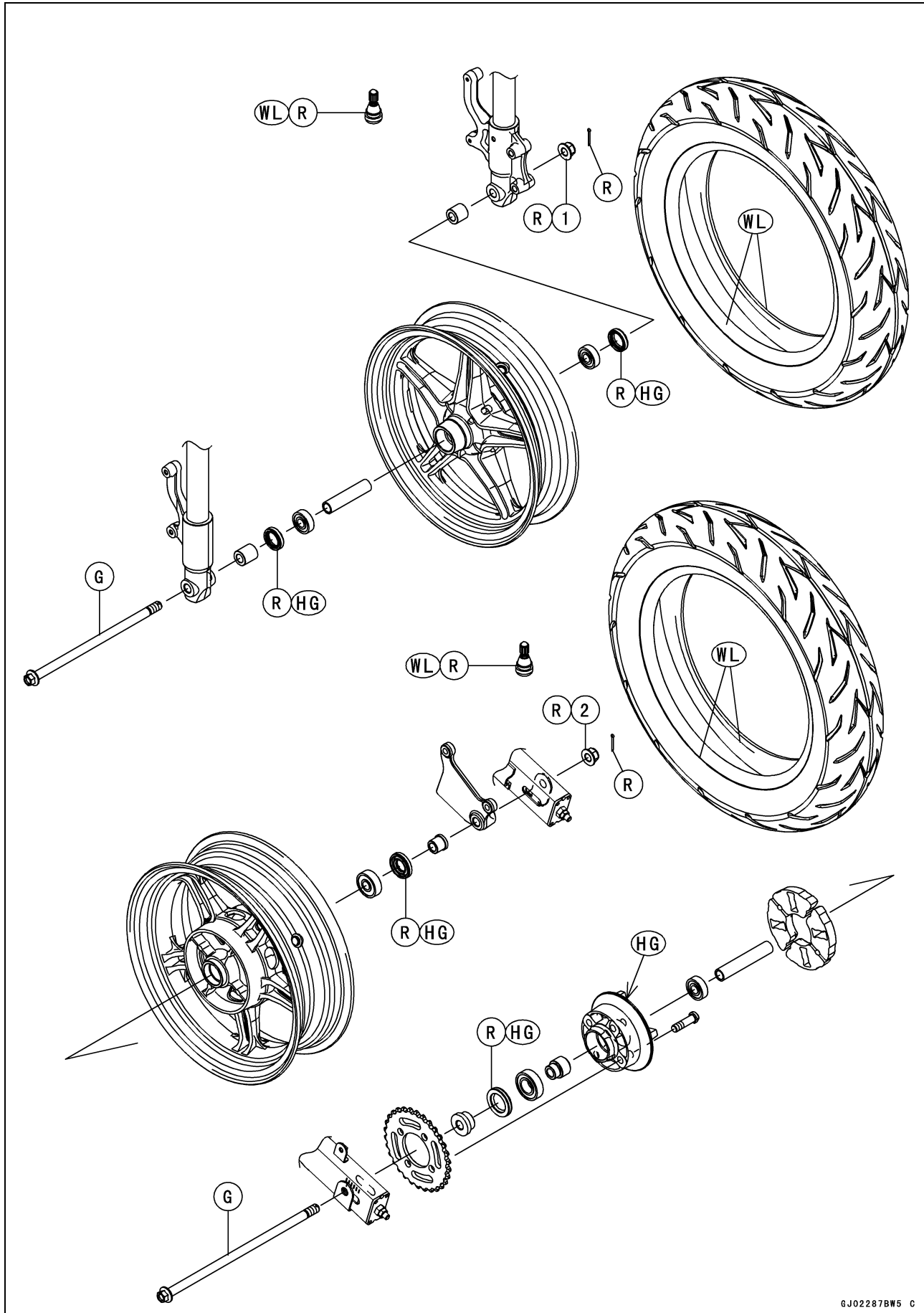



**Exploded View**

<b>No.</b>	<b>Fastener</b>	<b>Torque</b>			<b>Remarks</b>
		<b>N·m</b>	<b>kgf·m</b>	<b>ft·lb</b>	
1	Front Axle Nut	64	6.5	47	R
2	Rear Axle Nut	64	6.5	47	R

G: Apply grease.

HG: Apply high-temperature grease.

R: Replacement Parts

WL: Apply soap and water solution or lubber lubricant.

## 9-4 WHEELS/TIRES

### Specifications

Item	Standard	Service Limit
<b>Wheels (Rims)</b>		
Rim Runout:		
Axial	TIR 0.5 mm (0.02 in.) or less	TIR 1.0 mm (0.04 in.)
Radial	TIR 0.8 mm (0.03 in.) or less	TIR 1.0 mm (0.04 in.)
Axle Runout/100 mm (3.94 in.)	TIR 0.03 mm (0.001 in.) or less	TIR 0.2 mm (0.008 in.)
Rim Size:		
Front	J12 × MT2.50	— — —
Rear	J12 × MT3.50	— — —
<b>Tires</b>		
Air Pressure (when Cold):		
Front	150 kPa (1.50 kgf/cm <sup>2</sup> , 22 psi)	— — —
Rear	200 kPa (2.00 kgf/cm <sup>2</sup> , 29 psi)	— — —
Tread Depth:		
Front	4.2 mm (0.17 in.)	1 mm (0.04 in.)
Rear	4.7 mm (0.19 in.)	Up to 130 km/h (80 mph): 2 mm (0.08 in.), Over 130 km/h (80 mph): 3 mm (0.12 in.)
Standard Tires:	Make, Type	Size
Front	IRC, NR77U	100/90-12 49J
Rear	IRC, NR77U	120/70-12 51L

### **WARNING**

**Some replacement tires may adversely affect handling and cause an accident resulting in serious injury or death. To ensure proper handling and stability, use only the recommended standard tires for replacement, inflated to the standard pressure.**

Special Tools

Bearing Driver Set:  
57001-1129

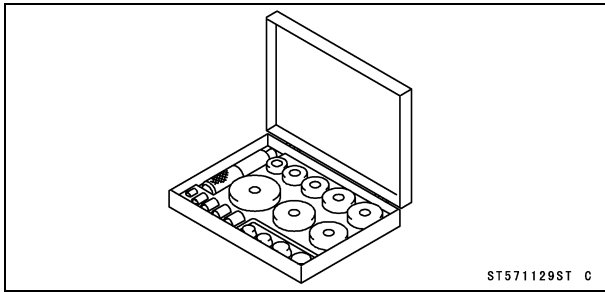

Bearing Remover Head,  $\phi 10 \times \phi 12$ :  
57001-1266

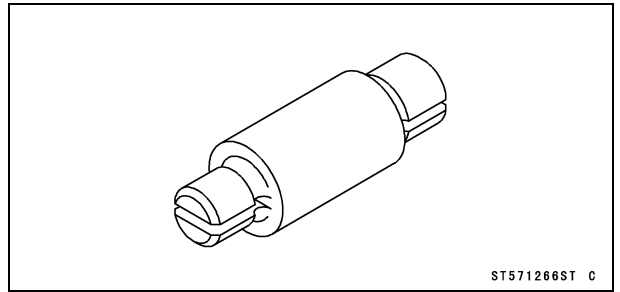

Jack:  
57001-1238

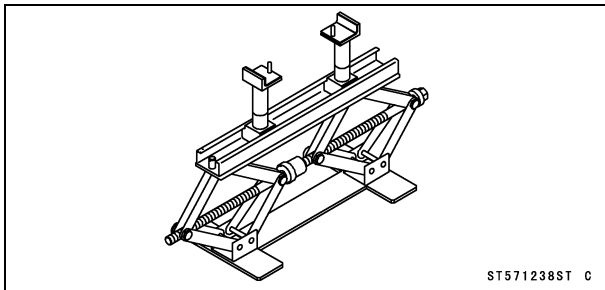

Jack Attachment:  
57001-1608

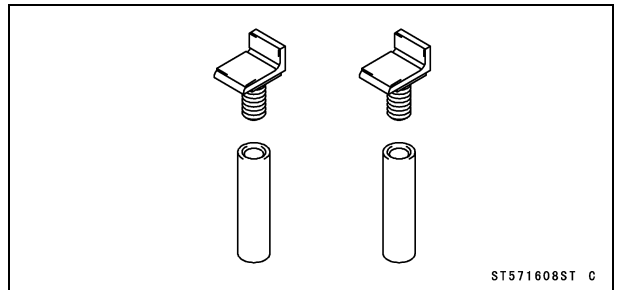

Bearing Remover Shaft,  $\phi 9$ :  
57001-1265

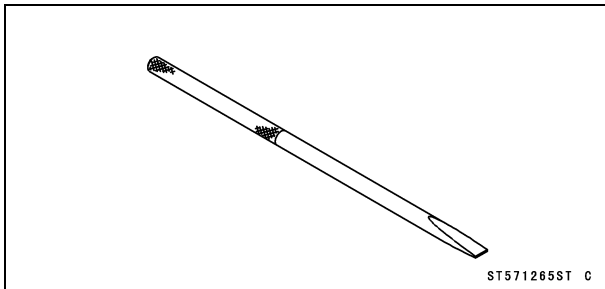

## 9-6 WHEELS/TIRES

### Wheels (Rims)

#### Front Wheel Removal

- Remove:
  - Lower Fairing (see Lower Fairing Removal in the Frame chapter)
  - Front Caliper (see Front Caliper Removal in the Brakes chapter)
  - Cotter Pin [A]
  - Axle Nut [B]
- Raise the front wheel off the ground using the jack.

**Special Tools - Jack: 57001-1238**

**Jack Attachment: 57001-1608**

- Pull out the axle [A] to the left side while supporting the front wheel.
- Remove the front wheel from the fork legs.

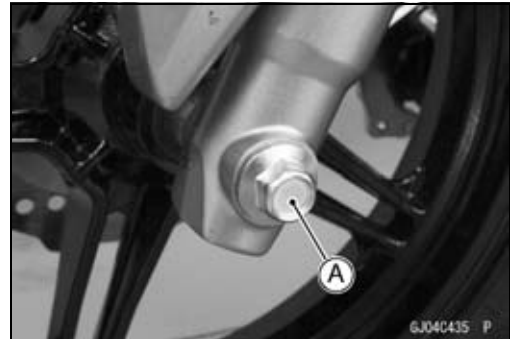
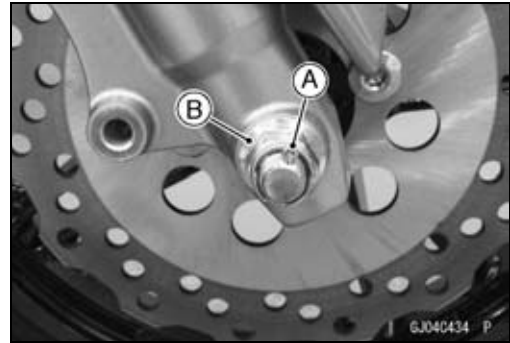

#### NOTICE

**Do not lay the wheel on the ground with the disc facing down. This can damage or warp the disc. Place blocks under the wheel so that the disc does not touch the ground.**

#### Front Wheel Installation

- Apply high-temperature grease to the grease seal lips.
- Install the collars [A] on both sides of the hub.

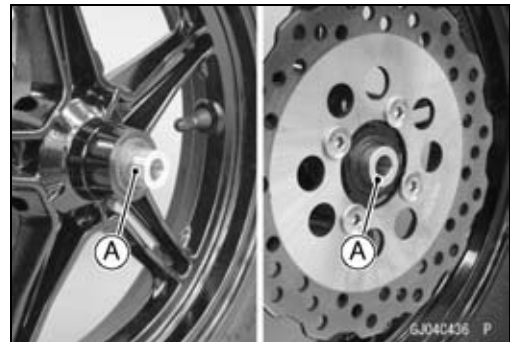

- Apply a thin coat of grease [A] to the front axle [B] for rust prevention.
  - About 10 mm (0.4 in.) [C]
  - About 70 mm (2.8 in.) [D]

#### NOTE

○ Do not apply grease to the thread portion of the axle.

- ★ If the front axle nut adhere, wipe off any grease.

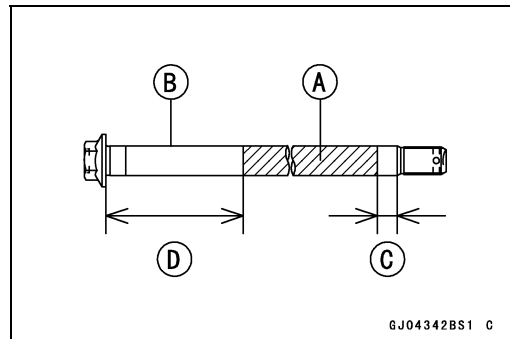

- Replace the front axle nut [A] with a new one.
- Insert the front axle from the left side of the wheel, and tighten the front axle nut.

**Torque - Front Axle Nut: 64 N·m (6.5 kgf·m, 47 ft·lb)**

- Wipe off excess grease if necessary.
- Replace the cotter pin [B] with a new one.
- Insert the cotter pin and bend the pin ends [C].

#### WARNING

**A loose axle nut can lead to an accident resulting in serious injury or death. Tighten the axle nut to the proper torque and install a new cotter pin.**

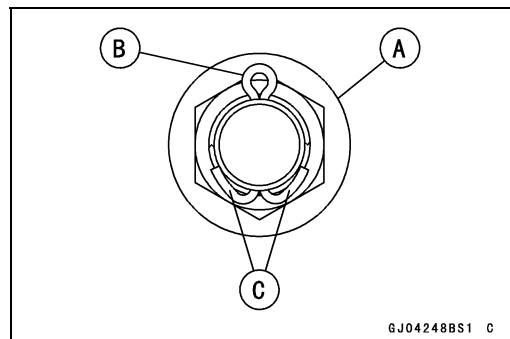

## Wheels (Rims)

- Install the removed parts (see appropriate chapters).
- Check the front brake effectiveness (see Brake Operation Inspection in the Periodic Maintenance chapter).

### **⚠ WARNING**

**After servicing, it takes several applications of the brake lever before the brake pads contact the disc, which could result in increased stopping distance and cause an accident resulting in injury or death. Do not attempt to ride the motorcycle until a firm brake lever is obtained by pumping the lever until the pads are against the disc.**

### **Rear Wheel Removal**

- Raise the rear wheel off the ground with the stand [A].



- Remove:
  - Rear Caliper (see Rear Caliper Removal in the Brakes chapter)
  - Cotter Pin [A]
  - Axle Nut [B]
  - Axle [C] (from Left Side)
  - Wheel Alignment Indicator [D] (Both Sides)
  - Chain Adjuster [E] (Both Sides)

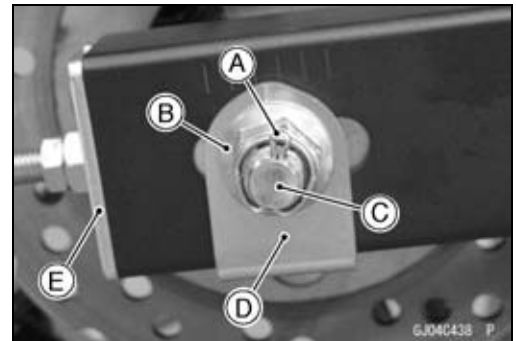

- Remove the drive chain [A] from the rear sprocket toward the left.
- Move the rear wheel back and remove it.

### **NOTICE**

**Do not lay the wheel on the ground with the disc facing down. This can damage or warp the disc. Place blocks under the wheel so that the disc does not touch the ground.**

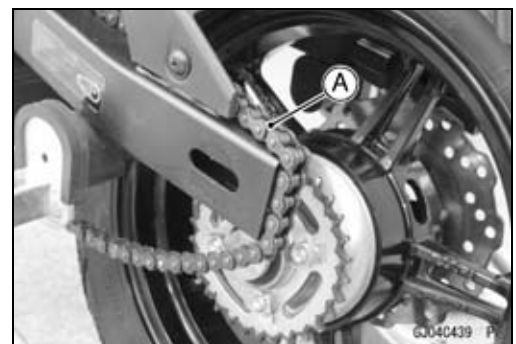

## 9-8 WHEELS/TIRES

### Wheels (Rims)

#### Rear Wheel Installation

- Apply high-temperature grease to the grease seal lips.
- Install the collars [A] on the both sides of the hub.

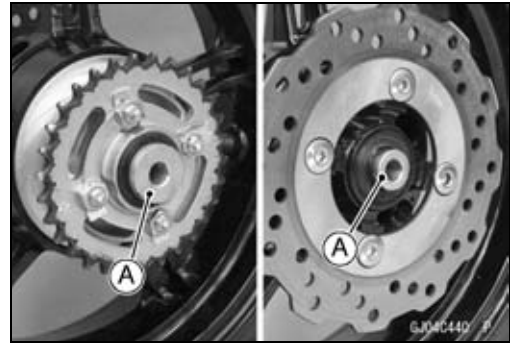

- Align the groove [A] on the caliper bracket [B] with the stopper [C] on the swingarm [D].
- Install the caliper bracket between the rear wheel and swingarm.

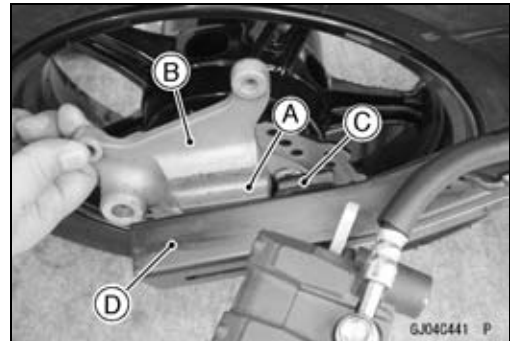

- Apply a thin coat of grease [A] to the rear axle [B] for rust prevention.
  - About 10 mm (0.4 in.) [C]
  - About 70 mm (2.8 in.) [D]

#### NOTE

○ Do not apply grease to the thread portion of the axle.

- ★ If the rear axle nut adhere, wipe off any grease.

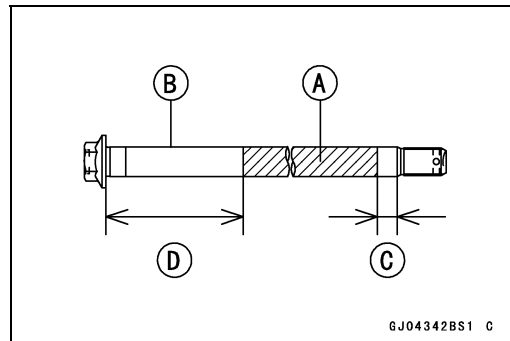

- Engage the drive chain with the rear sprocket.
- Install the left wheel alignment indicator [A] and chain adjuster [B] on both sides.
- Install the rear axle [C] from the left side.

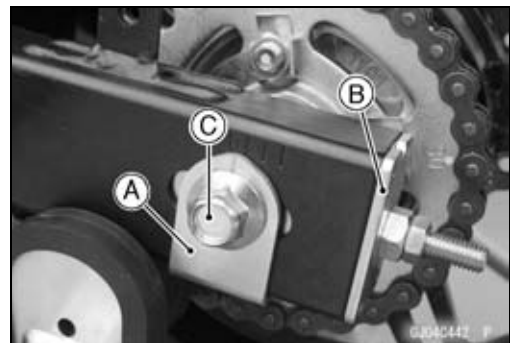

- Install the right wheel alignment indicator [A].
- Adjust the drive chain slack after installation (see Drive Chain Slack Inspection in the Periodic Maintenance chapter).
- Replace the rear axle nut [B] with a new one.

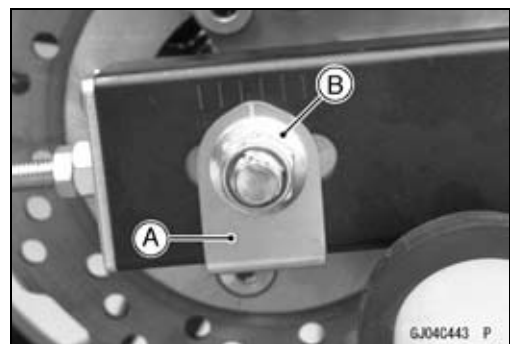

## Wheels (Rims)

- Tighten:
  - Torque - Rear Axle Nut [A]: 64 N·m (6.5 kgf·m, 47 ft·lb)
- Wipe off excess grease if necessary.
- Replace the cotter pin [B] with a new one.
- Insert the cotter pin and bend the pin ends [C].

### **⚠ WARNING**

**A loose axle nut can lead to an accident resulting in serious injury or death. Tighten the axle nut to the proper torque and install a new cotter pin.**

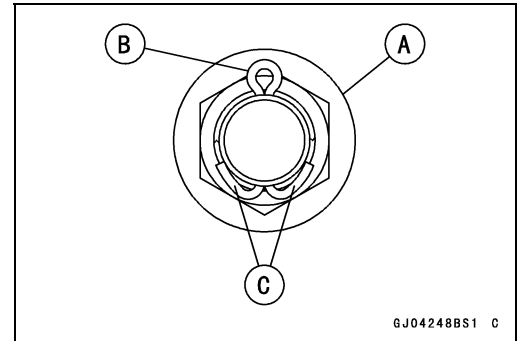

- Install the rear caliper (see Caliper Installation in the Brakes chapter).
- Check the rear brake effectiveness (see Brake Operation Inspection in the Periodic Maintenance chapter).

### **⚠ WARNING**

**After servicing, it takes several applications of the brake pedal before the brake pads contact the disc, which could result in increased stopping distance and cause an accident resulting in injury or death. Do not attempt to ride the motorcycle until a firm brake pedal is obtained by pumping the pedal until the pads are against the disc.**

### **Wheel Inspection**

- Raise the front/rear wheel off the ground.
  - Special Tools - Jack: 57001-1238
  - Jack Attachment: 57001-1608
- Spin the wheel lightly, and check for roughness or binding.
- ★ If roughness or binding is found, replace the hub bearings (see Hub Bearing Removal/Installation).
- Inspect the wheel for small cracks, dents, bending, or warp.
- ★ If there is any damage to the wheel, replace the wheel.
- Remove the wheel, and support it with the tire by the axle.
- Measure the rim runout, axial [A] and radial [B], with a dial gauge.
- ★ If rim runout exceeds the service limit, check the hub bearings (see Hub Bearing Inspection).
- ★ If the problem is not due to the bearings, replace the wheel.

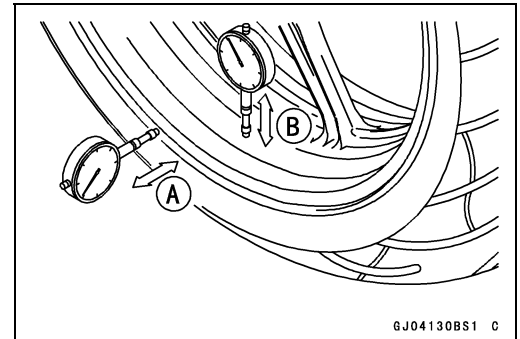

#### **Rim Runout (with tire installed)**

##### **Standard:**

Axial	TIR 0.5 mm (0.02 in.) or less
Radial	TIR 0.8 mm (0.03 in.) or less

##### **Service Limit:**

Axial	TIR 1.0 mm (0.04 in.)
Radial	TIR 1.0 mm (0.04 in.)

### **⚠ WARNING**

**Damaged wheel parts may fail and cause an accident resulting in serious injury or death. Never attempt to repair a damaged wheel part. If the wheel part is damaged, it must be replaced with a new one.**

## 9-10 WHEELS/TIRES

### Wheels (Rims)

#### ***Axle Inspection***

- Remove the front and rear axles (see Front/Rear Wheel Removal).
- Visually inspect the front and rear axle for damages.
- ★ If the axle is damaged or bent, replace it.
- Place the axle in V blocks that are 100 mm (3.94 in.) [A] apart, and set a dial gauge [B] on the axle at a point halfway between the blocks. Turn [C] the axle to measure the runout. The difference between the highest and lowest dial readings is the amount of runout.
- ★ If axle runout exceeds the service limit, replace the axle.

#### **Axle Runout/100 mm (3.94 in.)**

**Standard: TIR 0.03 mm (0.001 in.) or less**

**Service Limit: TIR 0.2 mm (0.008 in.)**

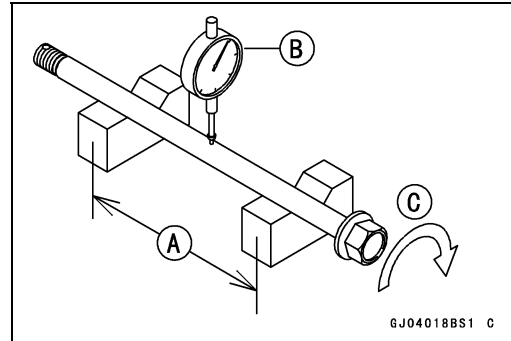



**Tires**

**Air Pressure Inspection/Adjustment**

- Refer to the Air Pressure Inspection in the Periodic Maintenance chapter.

**Tire Inspection**

- Refer to the Wheel/Tire Damage Inspection in the Periodic Maintenance chapter.

**Tire Removal**

- Remove:
  - Wheels (see Front/Rear Wheel Removal)
  - Valve Core (Let out the air)
- To maintain wheel balance, mark the valve stem position on the tire with chalk so that the tire can be reinstalled in the same position.
  - Chalk Mark or Yellow Mark [A]
  - Air Valve [B]
  - Align [C]
- Lubricate the tire beads and rim flanges on both sides with a soap and water solution or rubber lubricant. This helps the tire beads slip off the rim flanges.

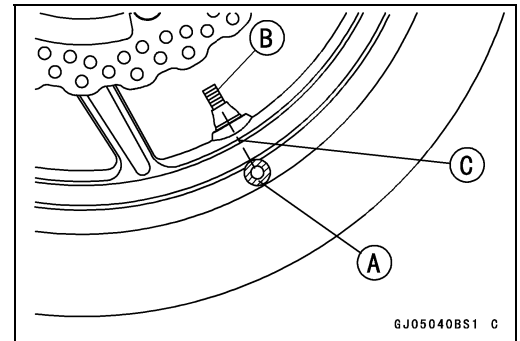

**NOTICE**

**Never lubricate with engine oil or petroleum distillates because they will deteriorate the tire.**

- Remove the tire from the rim using a suitable commercially available tire changer.

**NOTE**

○ *The tires cannot be removed with hand tools because they fit the rims too tightly.*

**Tire Installation**

**WARNING**

**Some replacement tires may adversely affect handling and cause an accident resulting in serious injury or death. To ensure proper handling and stability, use only the recommended standard tires for replacement, inflated to the standard pressure.**

- Inspect the rim and tire, and replace them if necessary.
- Clean the sealing surfaces of the rim and tire, and smooth the sealing surfaces of the rim with a fine emery cloth if necessary.
- Remove the air valve and discard it.

**NOTICE**

**Replace the air valve whenever the tire is replaced. Do not reuse the air valve.**

# 9-12 WHEELS/TIRES

## Tires

- Install a new valve in the rim.
- Remove the valve cap, lubricate the stem seal [A] with a soap and water solution or rubber lubricant, and pull [B] the valve stem through the rim from the inside out until it snaps into place.

### NOTICE

**Do not use engine oil or petroleum distillates to lubricate the stem because they will deteriorate the rubber.**

- The air valve is as shown.

- Valve Cap [A]
- Valve Core [B]
- Stem Seal [C]
- Valve Stem [D]
- Valve Seat [E]
- Valve Opened [F]

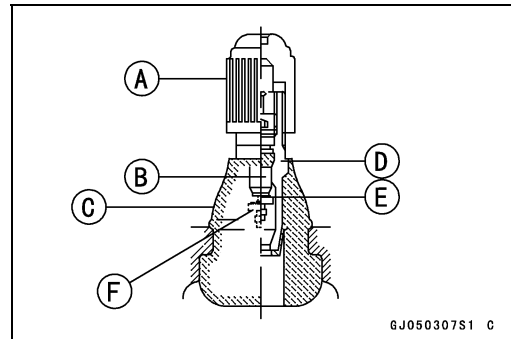
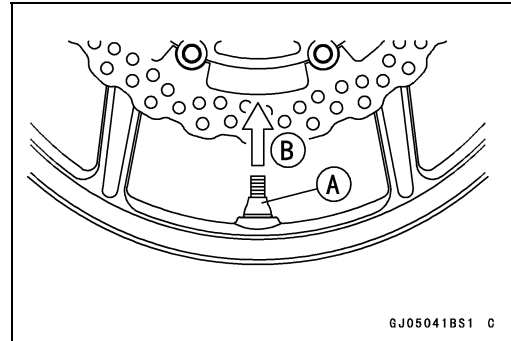

- Check the tire rotation mark for front wheel on the front tire and install it on the rim.  
Tire Rotation Mark for Front Wheel [A]  
Rotating Direction [B]

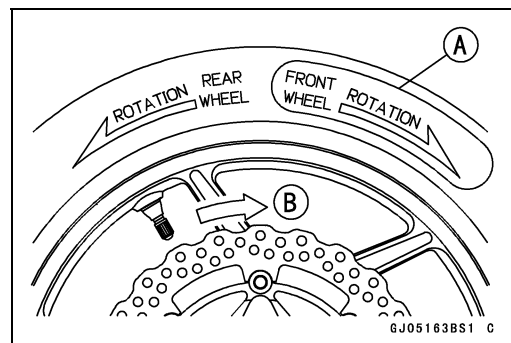

- Check the tire rotation mark on the rear tire and install it on the rim.  
Tire Rotation Mark [A]  
Rotating Direction [B]

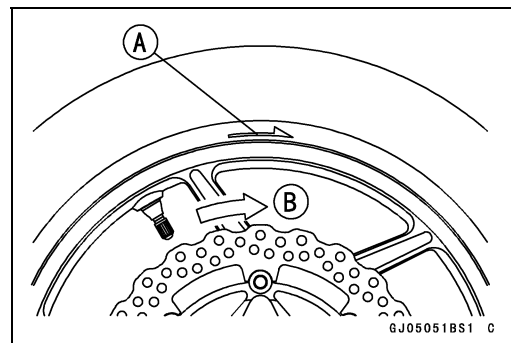

**Tires**

- Position the tire on the rim so that the valve [A] align with the tire balance mark [B] (the chalk mark made during removal, or the yellow paint mark on a new tire).
- Install the tire bead over the rim flange using a suitable commercially available tire changer.
- Lubricate the tire beads and rim flanges with a soap and water solution or rubber lubricant to help seat the tire beads in the sealing surfaces of the rim while inflating the tire.
- Center the rim in the tire beads, and inflate the tire with compressed air until the tire beads seat in the sealing surfaces.

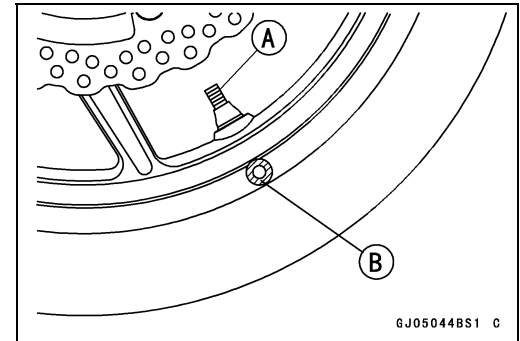

**⚠ WARNING**

**Overinflating a tire can cause it to explode, causing serious injury or death. Be sure to install the valve core whenever inflating the tire, and do not inflate the tire to more than 400 kPa (4.0 kgf/cm<sup>2</sup>, 57 psi).**

- Check to see that the rim lines [A] on both sides of the tire sidewalls are parallel with the rim flanges.
- ★ If the rim flanges and tire sidewall rim lines are not parallel, remove the valve core.
- Lubricate the rim flanges and tire beads.
- Install the valve core and inflate the tire again.
- After the tire beads seat in the rim flanges, check for air leakage.
- Inflate the tire slightly above standard inflation.
- Use a soap and water solution or submerge the tire, and check for bubbles that would indicate leakage.
- Adjust the air pressure to the specified pressure (see Air Pressure Inspection in the Periodic Maintenance chapter).
- Install the air valve cap.

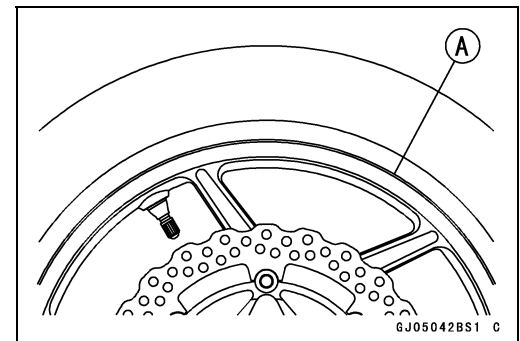

**Tire Repair**

Currently two types of repair for tubeless tires have come into wide use. One type is called a temporary (external) repair which can be carried out without removing the tire from the rim, and the other type is called permanent (internal) repair which requires tire removal. It is generally understood that higher running durability is obtained by permanent (internal) repairs than by temporary (external) ones. Also, permanent (internal) repairs have the advantage of permitting a thorough examination for secondary damage not visible from external inspection of the tire. For these reasons, Kawasaki does not recommend temporary (external) repair. Only appropriate permanent (internal) repairs are recommended. Repair methods may vary slightly from make to make. Follow the repair methods indicated by the manufacturer of the repair tools and materials so that safe results can be obtained.

# 9-14 WHEELS/TIRES

## Hub Bearing

### Hub Bearing Removal

- Remove the wheels (see Front/Rear Wheel Removal).
- Remove:
  - Collars
  - Grease Seal [A] (Both Sides)



- Use the bearing remover to remove the hub bearings [A].

### NOTICE

Do not lay the wheel on the ground with the disc facing down. This can damage or warp the disc. Place blocks under the wheel so that the disc does not touch the ground.

Special Tools - Bearing Remover Shaft,  $\phi 9$  [B]: 57001-1265  
Bearing Remover Head,  $\phi 10 \times \phi 12$  [C]: 57001-1266

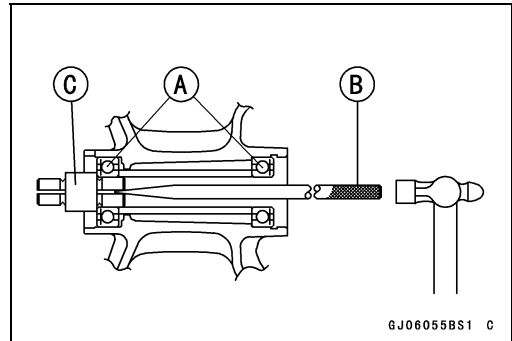

### Hub Bearing Installation

- Before installing the hub bearings, blow any dirt or foreign particles out of the hub with compressed air to prevent contamination of the bearings.
- Replace the bearings with new ones.

### NOTE

○ Install the front hub bearings with their sealed side facing out.

- By the following specified sequence, install the bearings.
- Press in the right side bearing [A] until it is bottomed.

Special Tool - Bearing Driver Set [B]: 57001-1129

- Install the collar into the hub from left side.
- Press in the left side bearing until it is bottomed.

Special Tool - Bearing Driver Set: 57001-1129

- Check that the both sides of bearing inner race turn at same times.

- Replace the grease seals with new ones.
- Press in the grease seals [A] so that the seal surface is flush [B] with the end of the hole.
- Apply high-temperature grease to the grease seal lips.

Special Tool - Bearing Driver Set [C]: 57001-1129

- Install the removed parts (see appropriate chapters).

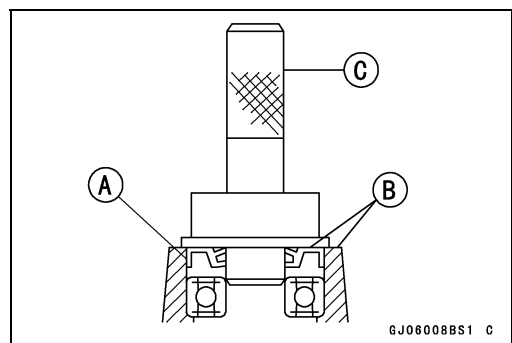
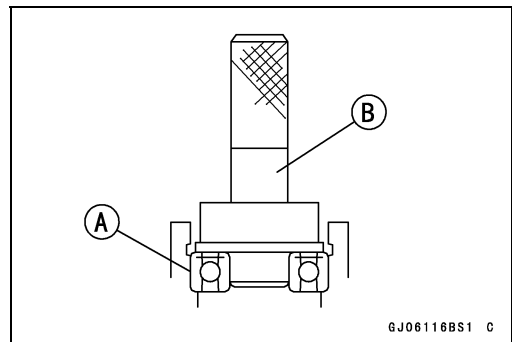

## Hub Bearing

### Hub Bearing Inspection

Since the hub bearings are made to extremely close tolerances, the clearance can not normally be measured.

#### NOTE

○ Do not remove any bearings for inspection. If any bearings are removed, they will need to be replaced with new ones.

- Turn each bearing in the hub back and forth [A] while checking for plays, roughness, or binding.
- ★ If bearing play, roughness, or binding is found, replace the bearing.
- Examine the bearing seal [B] for tears or leakage.
- ★ If the seal is torn or is leaking, replace the bearing.

### Hub Bearing Lubrication

#### NOTE

- When replacing the front hub bearing, pack grease to the new hub bearing from the non-sealed side.
- Since the rear hub bearings are packed with grease and sealed, lubrication is not required.

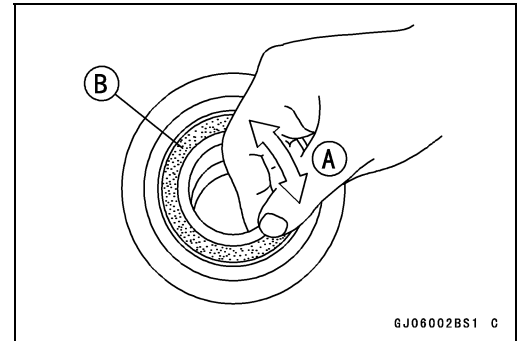



# Final Drive

## Table of Contents

Exploded View .....	10-2
Specifications .....	10-4
Special Tools .....	10-5
Drive Chain .....	10-6
Drive Chain Slack Inspection .....	10-6
Drive Chain Slack Adjustment .....	10-6
Wheel Alignment Inspection/Adjustment .....	10-6
Drive Chain Wear Inspection .....	10-6
Drive Chain Lubrication .....	10-6
Drive Chain Guide Wear Inspection .....	10-6
Drive Chain Removal .....	10-6
Drive Chain Installation .....	10-6
Sprockets, Coupling .....	10-8
Engine Sprocket Removal .....	10-8
Engine Sprocket Installation .....	10-8
Rear Sprocket Removal .....	10-8
Rear Sprocket Installation .....	10-9
Coupling Removal .....	10-9
Coupling Installation .....	10-9
Coupling Bearing Removal .....	10-10
Coupling Bearing Installation .....	10-10
Coupling Bearing Inspection .....	10-10
Coupling Bearing Lubrication .....	10-10
Coupling Damper Inspection .....	10-11
Sprocket Wear Inspection .....	10-11
Rear Sprocket Warp Inspection .....	10-11

# 10-2 FINAL DRIVE

## Exploded View

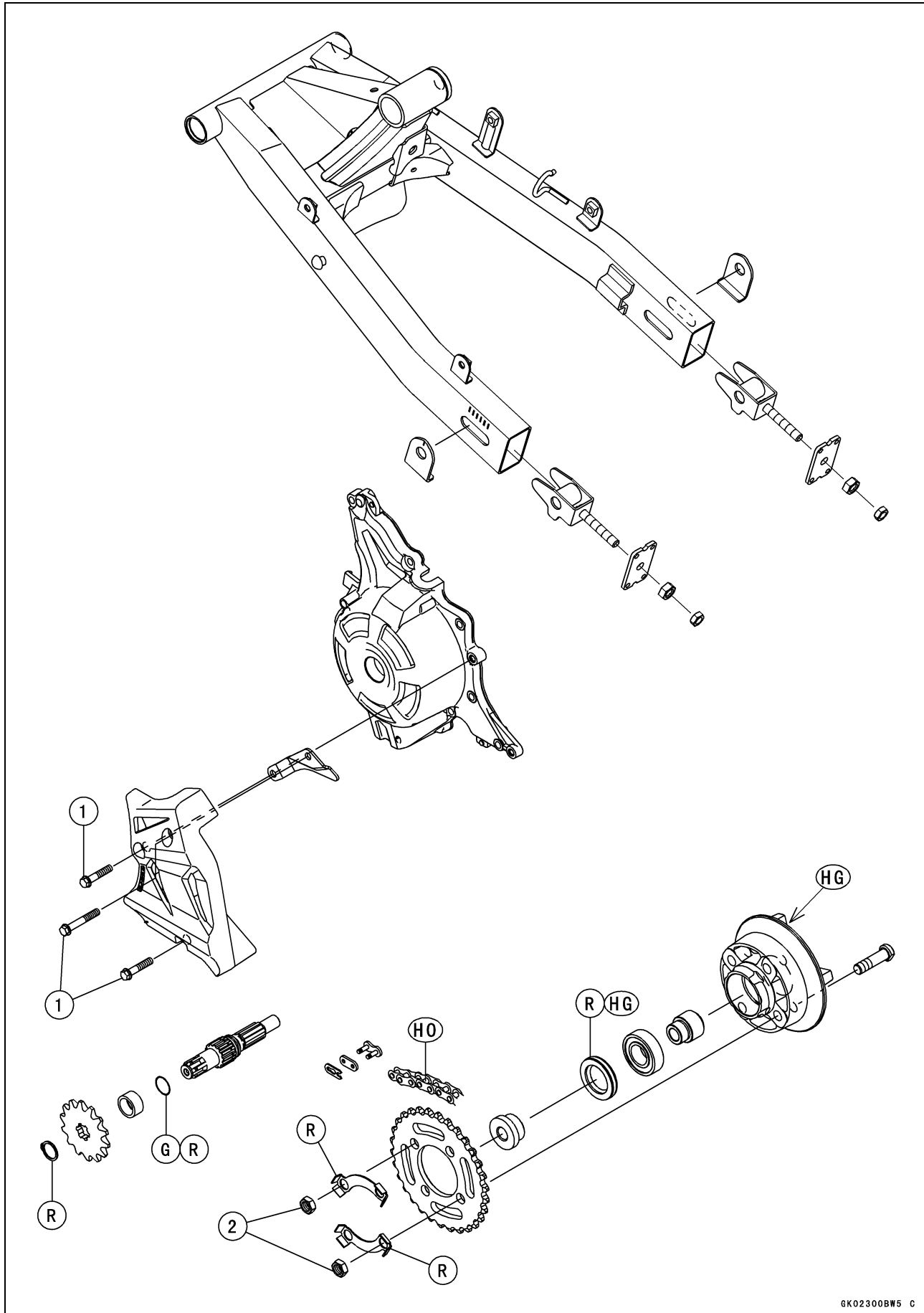



**Exploded View**

No.	Fastener	Torque			Remarks
		N·m	kgf·m	ft·lb	
1	Engine Sprocket Cover Bolts	5.2	0.53	46 in·lb	
2	Rear Sprocket Nuts	34	3.5	25	

G: Apply grease.

HG: Apply high-temperature grease.

HO: Apply heavy oil.

R: Replacement Parts

## 10-4 FINAL DRIVE

### Specifications

Item	Standard	Service Limit
<b>Drive Chain</b>		
Standard Chain:		
Make	DAIDO	---
Type	DID420AD	---
Link	100 links	---
Drive Chain Slack	20 ~ 35 mm (0.8 ~ 1.4 in.)	---
Chain 20-link Length	254.0 ~ 254.6 mm (10.00 ~ 10.02 in.)	259 mm (10.2 in.)
<b>Sprocket</b>		
Rear Sprocket Warp	TIR 0.4 mm (0.016 in.) or less	TIR 0.5 mm (0.020 in.)

**Special Tools**

---

**Outside Circlip Pliers:**  
**57001-144**

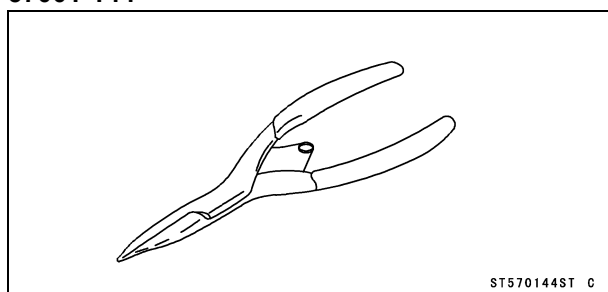

**Bearing Driver Set:**  
**57001-1129**

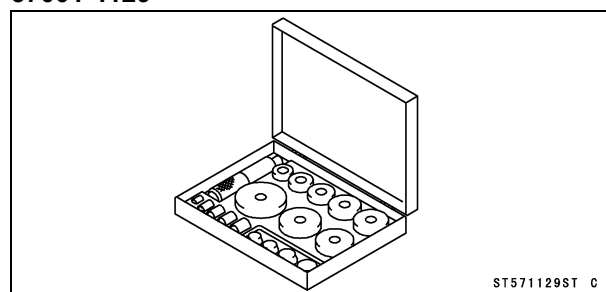

## 10-6 FINAL DRIVE

### Drive Chain

#### **Drive Chain Slack Inspection**

- Refer to the Drive Chain Slack Inspection in the Periodic Maintenance chapter.

#### **Drive Chain Slack Adjustment**

- Refer to the Drive Chain Slack Adjustment in the Periodic Maintenance chapter.

#### **Wheel Alignment Inspection/Adjustment**

- Refer to the Wheel Alignment Inspection in the Periodic Maintenance chapter.

#### **Drive Chain Wear Inspection**

- Refer to the Drive Chain Wear Inspection in the Periodic Maintenance chapter.

#### **Drive Chain Lubrication**

- Refer to the Drive Chain Lubrication Condition Inspection in the Periodic Maintenance chapter.

#### **Drive Chain Guide Wear Inspection**

- Refer to the Chain Guide Wear Inspection in the Periodic Maintenance chapter.

#### **Drive Chain Removal**

- Remove:
  - Mud Guard (see Mud Guard Removal in the Frame chapter)
  - Engine Sprocket Cover and Chain Guide (see Engine Sprocket Removal)
- Remove the master link clip [A] from the drive chain master link using pliers, and remove the master link.
- Free the drive chain from the sprockets, being careful that the chain does not get dirty from contact with the ground.

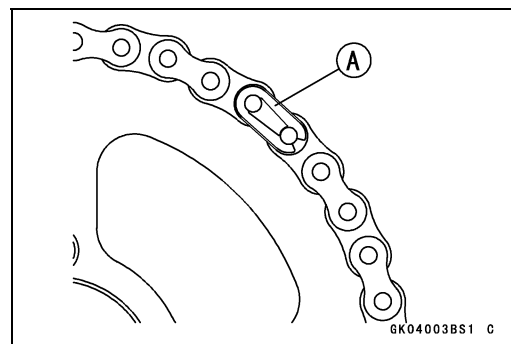

#### **Drive Chain Installation**

- Fit the drive chain back onto the sprockets with the ends at the rear sprocket.
- Install the master link from the frame side.
- Install the master link clip [A] so that the closed end of the "U" pointed in the direction of chain rotation [B].

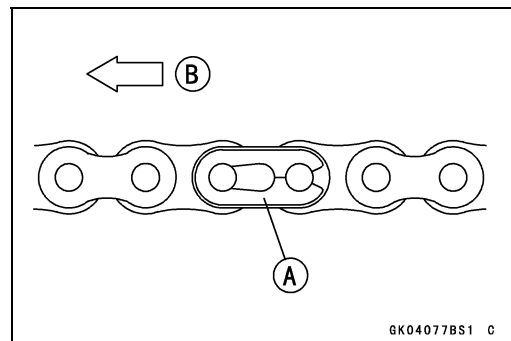

#### **⚠ WARNING**

Incorrect installation of the master link clip can allow it to catch on an adjacent part. If the clip dislodges, the chain could come a part, and this could result in rear wheel lockup and loss of control. Be sure the master link clip is installed correctly.

**Drive Chain**

---

- Install the removed parts (see appropriate chapters).
- Adjust the drive chain slack (see Drive Chain Slack Adjustment in the Periodic Maintenance chapter).
- Check the rear brake (see Brake Pedal Free Play Adjustment in the Brakes chapter).

## 10-8 FINAL DRIVE

### Sprockets, Coupling

#### Engine Sprocket Removal

- Remove:
  - Left Front Footpeg Bracket (see Front Footpeg Bracket Removal in the Frame chapter)
  - Shift Pedal (see Shift Pedal Removal in the Crankshaft/Transmission chapter)
- Remove the bolts [A] and engine sprocket cover [B] with the chain guide.
- Loosen the drive chain (see Drive Chain Slack Adjustment in the Periodic Maintenance chapter).
- Remove the circlip [A].
  - Special Tool - Outside Circlip Pliers: 57001-144**
- Pull the engine sprocket [B] with the drive chain [C] off the output shaft [D].
- Disengage the sprocket from the drive chain.

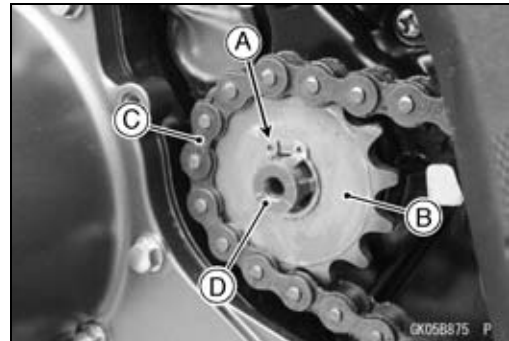
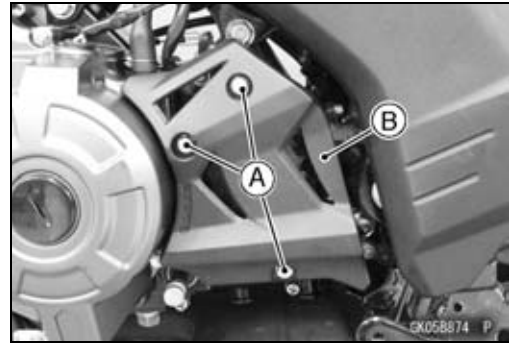

#### Engine Sprocket Installation

- Install the engine sprocket [A] so that the tooth number marking side [B] faces outward, and the drive chain together.
- Replace the circlip [C] with a new one.
- Install the circlip securely.
  - Special Tool - Outside Circlip Pliers: 57001-144**

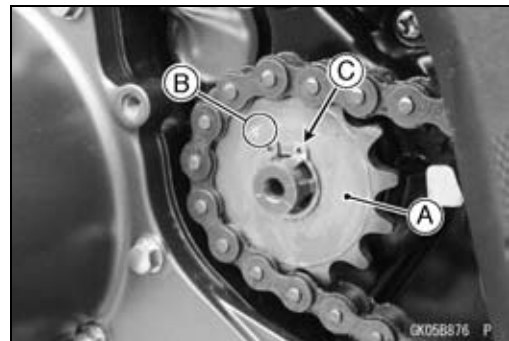

- Adjust the drive chain slack (see Drive Chain Slack Adjustment in the Periodic Maintenance chapter).
- Set the chain guide [A] to the engine sprocket cover [B].
- Install the engine sprocket cover.
- Tighten:
  - Torque - Engine Sprocket Cover Bolts: 5.2 N·m (0.53 kgf·m, 46 in·lb)**

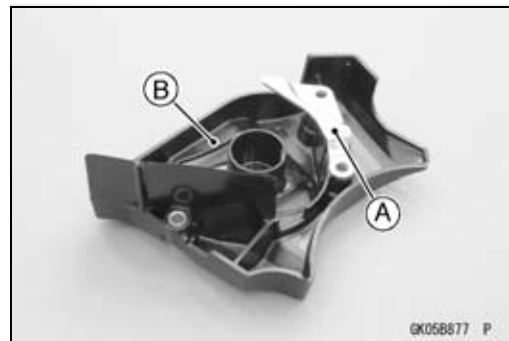

#### Rear Sprocket Removal

- Remove the rear wheel (see Rear Wheel Removal in the Wheels/Tires chapter).

#### NOTICE

**Do not lay the wheel on the ground with the disc facing down. This can damage or warp the disc. Place blocks under the wheel so that the disc does not touch the ground.**

- Straighten the double lockwashers [A] that they bent over the side of the rear sprocket nuts [B].
- Remove the rear sprocket nuts and double lockwashers.
- Remove the rear sprocket.



## Sprockets, Coupling

### Rear Sprocket Installation

- Install the rear sprocket [A] so that the marked side [B] faces outward.
- Replace the double lockwashers with new ones.
- Install the double lockwashers.
- Tighten:
  - Torque - Rear Sprocket Nuts: 34 N·m (3.5 kgf·m, 25 ft·lb)**
- Bend the one side of the double lockwashers over the rear sprocket nuts.
- Install the rear wheel (see Rear Wheel Installation in the Wheels/Tires chapter).

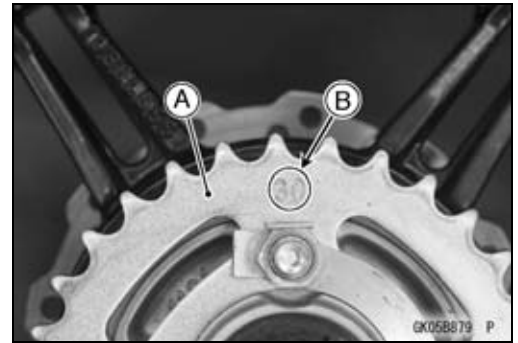

### Coupling Removal

- Remove:
  - Rear Wheel (see Rear Wheel Removal in the Wheels/Tires chapter)
  - Coupling [A]



### Coupling Installation

- Apply high-temperature grease to the following parts.
  - Grease Seal Lip [A]
  - Coupling Internal Surface [B]
- Install the collar [A].

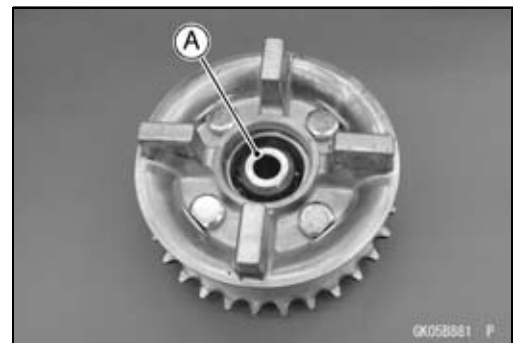
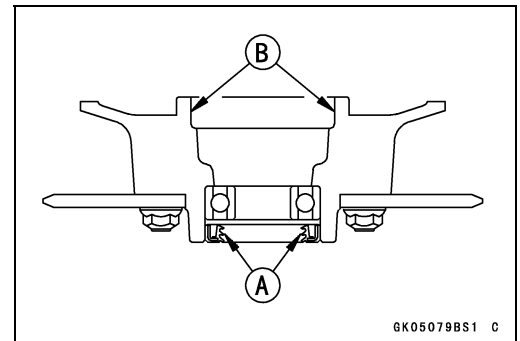

## 10-10 FINAL DRIVE

### Sprockets, Coupling

- Install the coupling to the rubber dampers so that align the projections [A] and groove [B] on the dampers.
- Install:
  - Rear Wheel (see Rear Wheel Installation in the Wheels/Tires chapter)

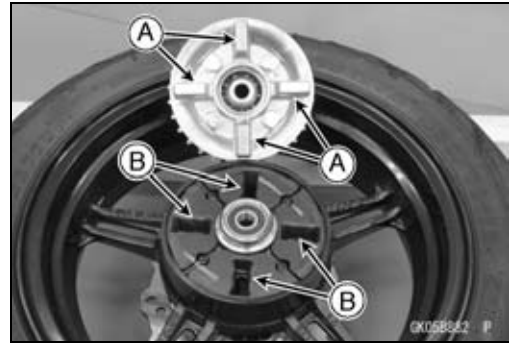

#### **Coupling Bearing Removal**

- Remove the coupling collar.
- Remove the oil seal.
- Using the bearing driver [A], remove the bearing [B] by tapping from the inside.

**Special Tool - Bearing Driver Set: 57001-1129**

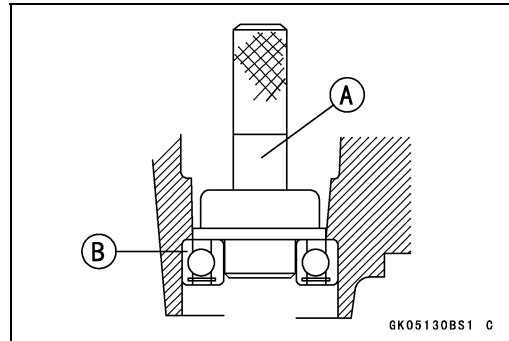

#### **Coupling Bearing Installation**

- Replace the bearing with a new one.
- Press in the bearing [A] so that the marked side faces out until it is bottomed.

**Special Tool - Bearing Driver Set [B]: 57001-1129**

- Replace the oil seal with a new one.
- Apply high-temperature grease to the oil seal lip.
- Press in the oil seal so that the seal surface is flush with the end of the hole.

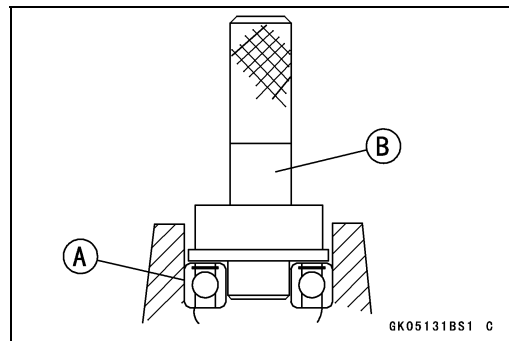

#### **Coupling Bearing Inspection**

Since the coupling bearing is made to extremely close tolerances, the clearance can not normally be measured.

##### **NOTE**

○It is not necessary to remove the coupling bearing for inspection. If the bearing is removed, it will need to be replaced with a new one.

- Turn the bearing in the coupling back and forth [A] while checking for plays, roughness or binding.
- ★ If the bearing play, roughness or binding is found, replace the bearing.
- Examine the bearing seal [B] for tears or leakage.
- ★ If the seal is torn or is leaking, replace the bearing.

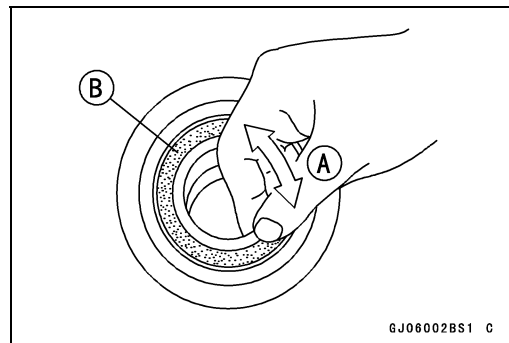

#### **Coupling Bearing Lubrication**

##### **NOTE**

○Since the coupling bearing is packed with grease and sealed, lubrication is not required.



## Sprockets, Coupling

### Coupling Damper Inspection

- Remove the rear wheel coupling, and inspect the rubber dampers [A].
- ★ Replace the dampers if they appear damaged or deteriorated.

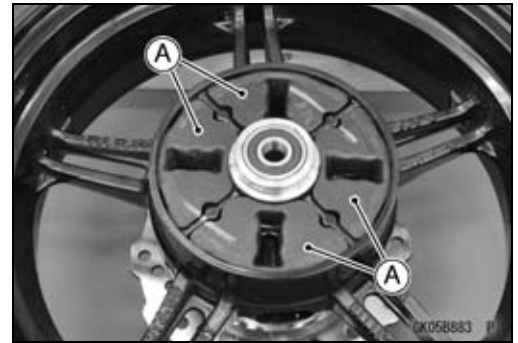

### Sprocket Wear Inspection

- Visually inspect the engine and rear sprocket teeth for wear and damage.
- ★ If they are worn as shown or other damaged, replace the sprocket with new ones and inspect the drive chain wear.
  - Worn Tooth (Engine Sprocket) [A]
  - Worn Tooth (Rear Sprocket) [B]
  - Direction of Rotation [C]

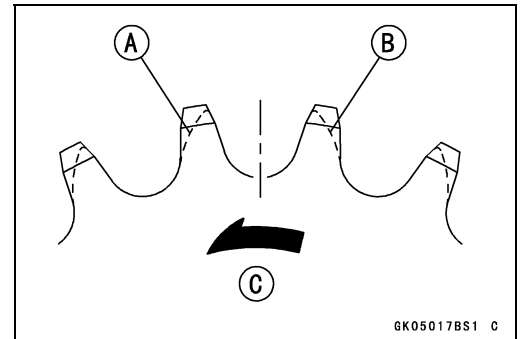

### NOTE

○ If a sprocket requires replacement, the chain is probably worn also. When replacing a sprocket, inspect the chain.

### Rear Sprocket Warp Inspection

- Raise the rear wheel so that it will turn freely, and set a dial gauge [A] against the rear sprocket [B] near the teeth as shown.
- Rotate [C] the rear wheel, and read the dial gauge. The difference between the highest and lowest dial gauge readings is the amount of runout (warp).
- ★ If the runout exceeds the service limit, replace the rear sprocket.

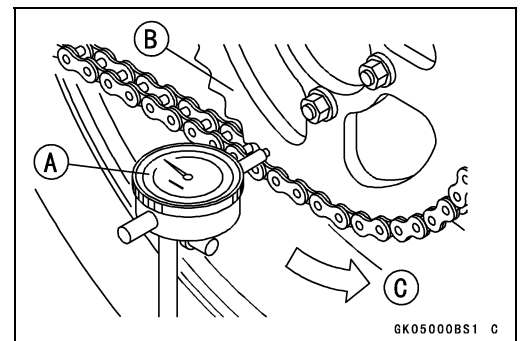

### Rear Sprocket Warp

Standard: TIR 0.4 mm (0.016 in.) or less

Service Limit: TIR 0.5 mm (0.020 in.)



# Brakes

## Table of Contents

Exploded View .....	11-2	Rear Brake Pad Removal .....	11-15
Specifications .....	11-6	Rear Brake Pad Installation .....	11-15
Special Tools .....	11-7	Brake Pad Wear Inspection .....	11-16
Brake Pedal .....	11-8	Master Cylinder .....	11-17
Brake Pedal Position Inspection ..	11-8	Front Master Cylinder Removal ...	11-17
Brake Pedal Position Adjustment	11-8	Front Master Cylinder Installation	11-17
Brake Pedal Removal .....	11-8	Rear Master Cylinder Removal....	11-17
Brake Pedal Installation .....	11-9	Rear Master Cylinder Installation.	11-18
Calipers .....	11-10	Front Master Cylinder	
Front Caliper Removal .....	11-10	Disassembly .....	11-18
Rear Caliper Removal.....	11-10	Rear Master Cylinder	
Caliper Installation .....	11-10	Disassembly .....	11-18
Front Caliper Disassembly .....	11-10	Master Cylinder Assembly .....	11-19
Front Caliper Assembly.....	11-11	Master Cylinder Inspection .....	11-19
Rear Caliper Disassembly .....	11-11	Brake Disc .....	11-20
Rear Caliper Assembly .....	11-11	Brake Disc Removal .....	11-20
Caliper Fluid Seal Damage		Brake Disc Installation .....	11-20
Inspection.....	11-11	Brake Disc Wear Inspection.....	11-20
Caliper Dust Seal Damage		Brake Disc Warp Inspection.....	11-20
Inspection.....	11-11	Brake Fluid .....	11-21
Caliper Boots Inspection .....	11-12	Brake Fluid Level Inspection.....	11-21
Caliper Piston and Cylinder		Brake Fluid Change .....	11-21
Damage Inspection .....	11-12	Brake Line Bleeding.....	11-21
Caliper Holder Pin Inspection .....	11-13	Brake Hose.....	11-26
Brake Pad.....	11-14	Brake Hose Removal/Installation.	11-26
Front Brake Pad Removal.....	11-14	Brake Hose Inspection.....	11-26
Front Brake Pad Installation.....	11-14		

# 11-2 BRAKES

## Exploded View

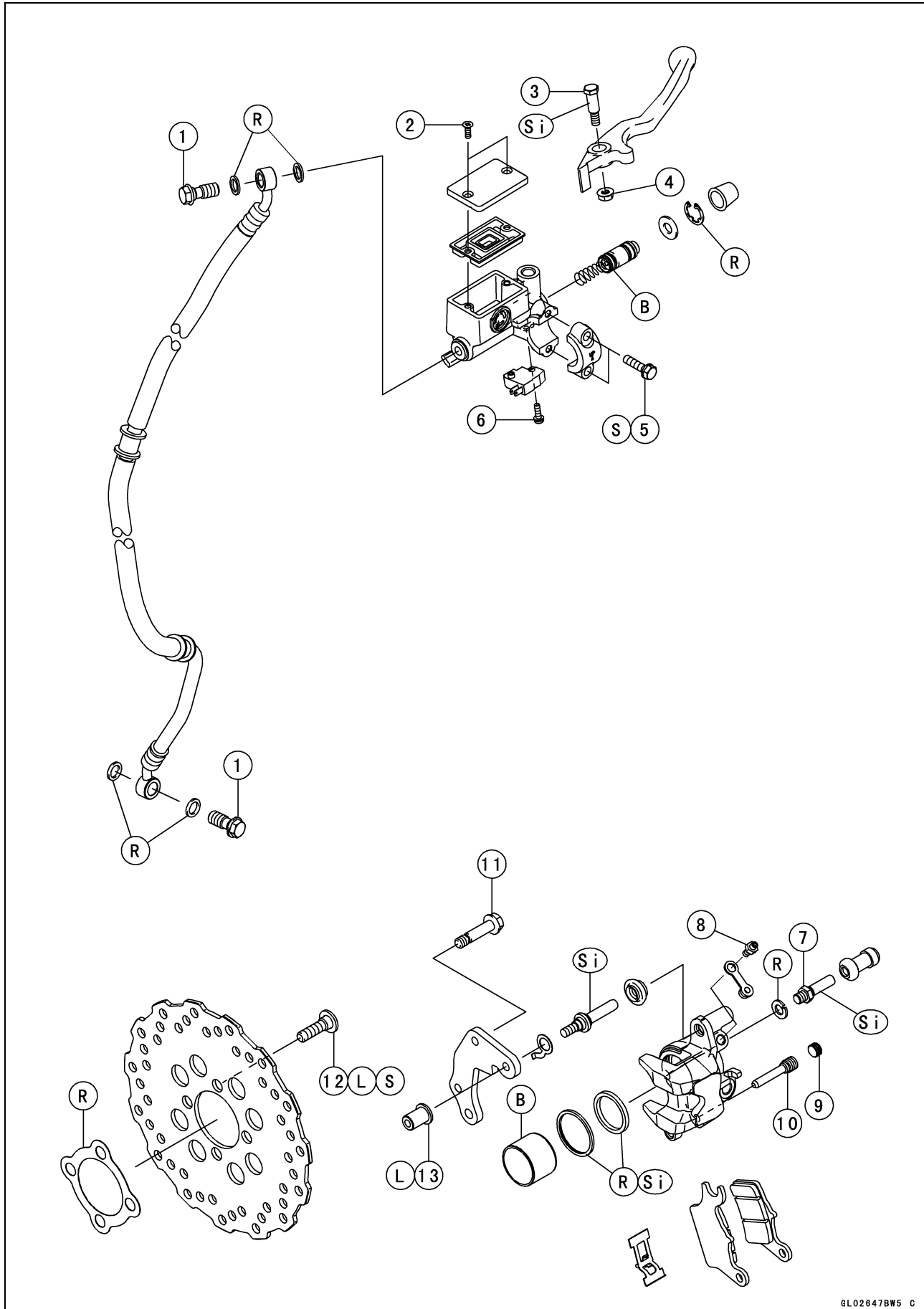

## Exploded View

No.	Fastener	Torque			Remarks
		N·m	kgf·m	ft·lb	
1	Brake Hose Banjo Bolts	25	2.5	18	
2	Front Brake Reservoir Cap Screws	1.5	0.15	13 in·lb	
3	Brake Lever Pivot Bolt	5.9	0.60	52 in·lb	Si
4	Brake Lever Pivot Bolt Locknut	5.9	0.60	52 in·lb	
5	Front Master Cylinder Clamp Bolts	8.8	0.90	78 in·lb	S
6	Front Brake Light Switch Screw	1.2	0.12	11 in·lb	
7	Front Caliper Holder Pin	17.2	1.75	12.7	Si
8	Bleed Valve	7.8	0.80	69 in·lb	
9	Front Caliper Pad Pin Plug	2.5	0.25	22 in·lb	
10	Front Caliper Pad Pin	17.2	1.75	12.7	
11	Front Caliper Mounting Bolts	25	2.5	18	
12	Front Brake Disc Mounting Bolts	27	2.8	20	L, S
13	Front Caliper Holder Pin Nut	22.1	2.25	16.3	L

B: Apply brake fluid.

L: Apply a non-permanent locking agent.

R: Replacement Parts

S: Follow the specified tightening sequence.

Si: Apply silicone grease.

# 11-4 BRAKES

## Exploded View

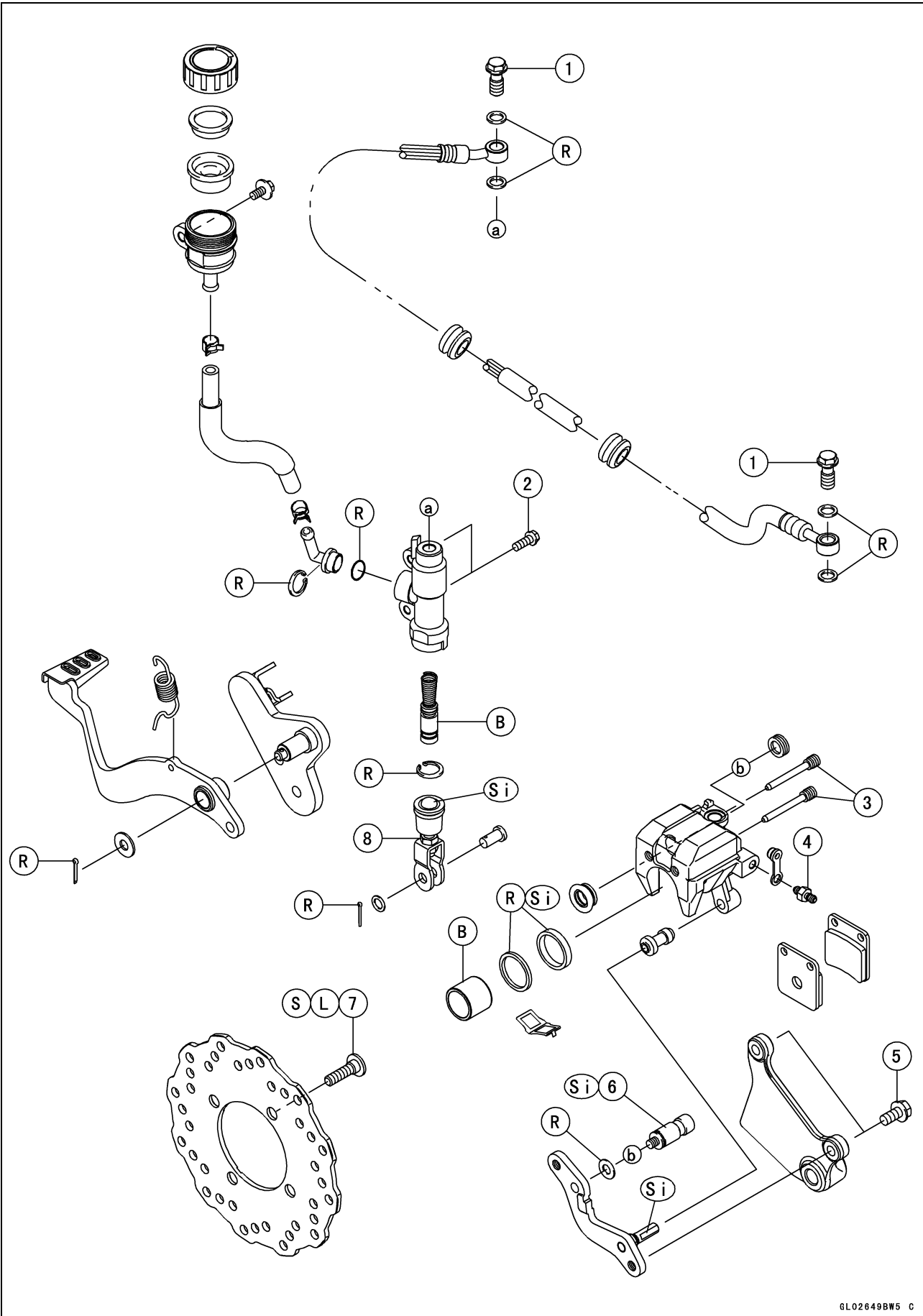

## Exploded View

No.	Fastener	Torque			Remarks
		N·m	kgf·m	ft·lb	
1	Brake Hose Banjo Bolts	25	2.5	18	
2	Rear Master Cylinder Mounting Bolts	8.8	0.90	78 in·lb	
3	Rear Caliper Pad Pins	17.2	1.75	12.7	
4	Bleed Valve	7.8	0.80	69 in·lb	
5	Rear Caliper Mounting Bolts	25	2.5	18	
6	Rear Caliper Holder Pin	17.2	1.75	12.7	Si
7	Rear Brake Disc Mounting Bolts	27	2.8	20	L, S
8	Rear Master Cylinder Push Rod Locknut	17.2	1.75	12.7	

B: Apply brake fluid.

L: Apply a non-permanent locking agent.

R: Replacement Parts

S: Follow the specified tightening sequence.

Si: Apply silicone grease.

# 11-6 BRAKES

## Specifications

Item	Standard	Service Limit
<b>Brake Lever, Brake Pedal</b> Brake Lever Position Brake Lever Free Play Pedal Free Play Pedal Position	Non-adjustable Non-adjustable Non-adjustable About 38 mm (1.5 in.) below top of footpeg	- - - - - - - - - - - -
<b>Brake Pads</b> Lining Thickness: Front Rear	4.0 mm (0.16 in.) 4.5 mm (0.18 in.)	1 mm (0.04 in.) 1 mm (0.04 in.)
<b>Brake Discs</b> Thickness: Front Rear Runout	3.3 ~ 3.7 mm (0.13 ~ 0.15 in.) 3.8 ~ 4.2 mm (0.15 ~ 0.17 in.) TIR 0.2 mm (0.008 in.) or less	3.0 mm (0.12 in.) 3.5 mm (0.14 in.) TIR 0.3 mm (0.01 in.)
<b>Brake Fluid</b> Grade: Front Rear	DOT3 or DOT4 DOT3	- - - - - -



**Special Tools**

**Jack:  
57001-1238**

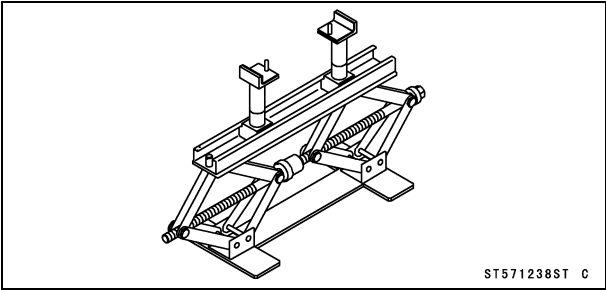

**Jack Attachment:  
57001-1608**

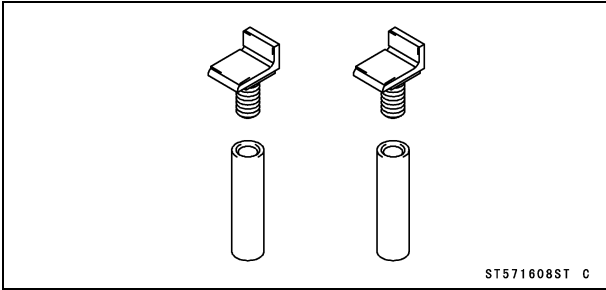

## 11-8 BRAKES

### Brake Pedal

#### Brake Pedal Position Inspection

- Check that the brake pedal [A] is in the correct position. Footpeg [B]

##### Pedal Position

Standard: About 38 mm (1.5 in.) [C] below top of footpeg

- ★ If it is incorrect, adjust the brake pedal position.

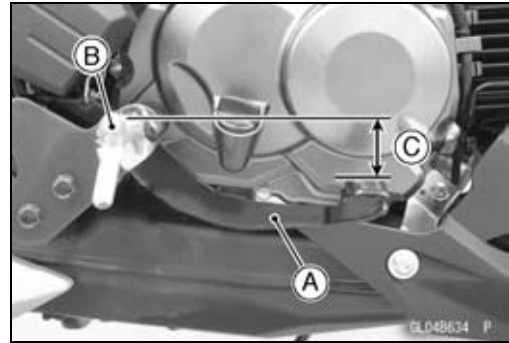

#### Brake Pedal Position Adjustment

##### NOTE

○ Usually it is not necessary to adjust the pedal position, but always adjust it when push rod locknut has been loosened.

- Remove the right side/frame cover (see Side/Frame Cover Removal in the Frame chapter).
- Loosen the locknut [A] and turn the push rod with the hex head [B] to achieve the correct pedal position.
- ★ If the length [C] shown is **75 ±1 mm (2.95 ±0.04 in.)**, the pedal position will be within the standard range.
- Tighten:

**Torque - Rear Master Cylinder Push Rod Locknut: 17.2 N·m (1.75 kgf·m, 12.7 ft·lb)**

- Check the brake light switch operation (see Brake Light Switch Operation Inspection in the Periodic Maintenance chapter).

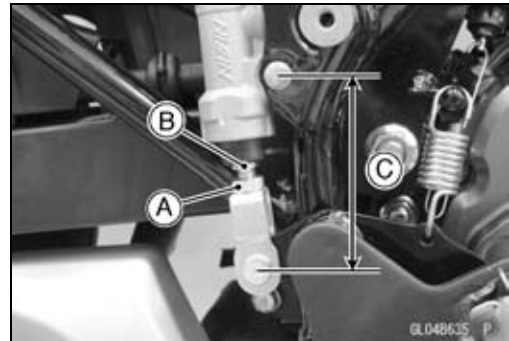

#### Brake Pedal Removal

- Remove:
  - Right Side/Frame Cover (see Side/Frame Cover Removal in the Frame chapter)
  - Right Front Footpeg Bracket Bolts [A]
  - Rear Brake Light Switch Spring Lower End [B]
  - Return Spring Lower End [C]
  
- Remove:
  - Cotter Pins [A]
  - Washers [B]
  - Joint Pin [C]
  - Right Front Footpeg Bracket [D]
  - Brake Pedal [E]

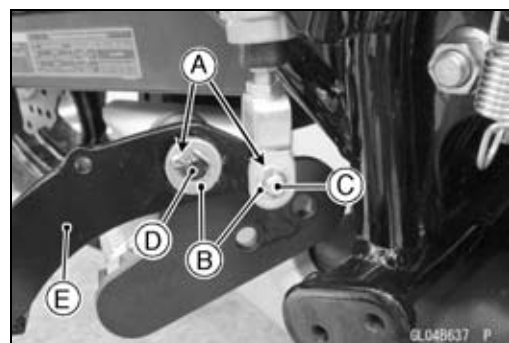
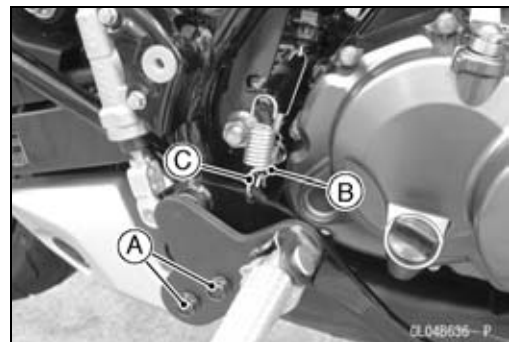

## Brake Pedal

### **Brake Pedal Installation**

- Apply grease to the sliding surface of the brake pedal and install it.
- Install:
  - Joint Pin [A]
  - Right Front Footpeg Bracket [B]
  - Washers [C]
- Replace the cotter pins [D] with new ones.
- Insert the cotter pins into the joint pin and right front footpeg bracket, and bend the pin ends.
- Hook the lower end of the return spring [A] to the brake pedal [B].
- Hook the lower end of the brake light switch spring [C] to the return spring.
- Tighten:
  - Torque - Right Front Footpeg Bracket Bolts [D]: 25 N·m (2.5 kgf·m, 18 in·lb)**
- Check:
  - Brake Pedal Position (see Brake Pedal Position Inspection)
  - Brake Light Switch Operation (see Brake Light Switch Operation Inspection in the Periodic Maintenance chapter)
- Install the right side/frame cover (see Side/Frame Cover Installation in the Frame chapter).

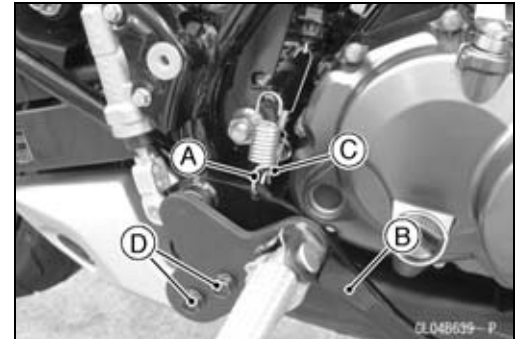
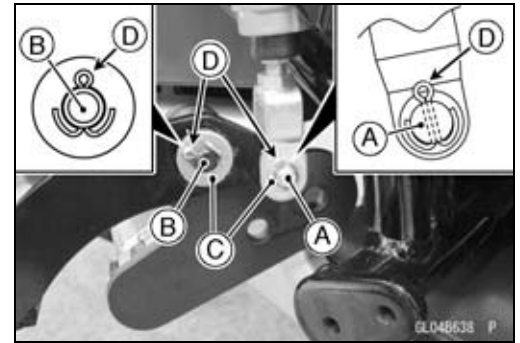

## 11-10 BRAKES

### Calipers

#### Front Caliper Removal

- Loosen the banjo bolt [A] at the brake hose lower end, and tighten it loosely.
- Remove the caliper mounting bolts [B] and caliper [C].
- Remove the banjo bolt to disconnect the brake hose [D] from the caliper.

#### NOTICE

Brake fluid quickly damages painted plastic surfaces; any spilled fluid should be completely washed away immediately.

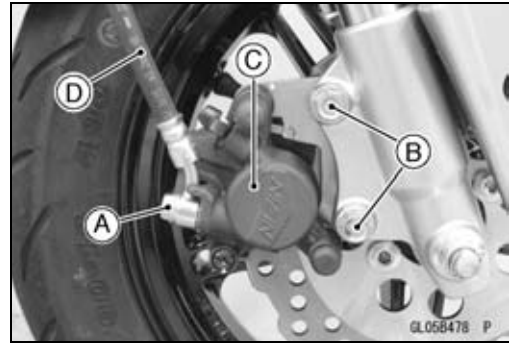

#### Rear Caliper Removal

- Loosen the banjo bolt [A] at the brake hose lower end, and tighten it loosely.
- Remove the caliper mounting bolts [B] and caliper [C].
- Remove the banjo bolt and disconnect the brake hose [D] from the caliper.

#### NOTICE

Brake fluid quickly damages painted plastic surfaces; any spilled fluid should be completely washed away immediately.

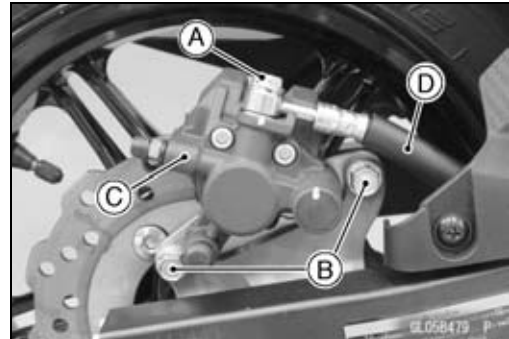

#### Caliper Installation

- Replace the washers on each side of hose fitting with new ones.
- Connect the brake hose to the caliper with the new washers and brake hose banjo bolt.
- Fit the brake hose to the stopper on the caliper.
- Install the caliper.
- Tighten:

##### Torque - Caliper Mounting Bolts:

Front: 25 N·m (2.5 kgf·m, 18 ft·lb)

Rear: 25 N·m (2.5 kgf·m, 18 ft·lb)

Brake Hose Banjo Bolts: 25 N·m (2.5 kgf·m, 18 ft·lb)

- Check the fluid level in the brake reservoirs.
- Bleed the brake line (see Brake Line Bleeding).
- Check the brake for good braking power, no brake drag, and no fluid leakage.

#### ⚠ WARNING

After servicing, it takes several applications of the brake lever or pedal before the brake pads contact the disc, which could result in increased stopping distance and cause an accident resulting in injury or death. Do not attempt to ride the motorcycle until a firm brake lever or pedal is obtained by pumping the lever or pedal until the pads are against the disc.

#### Front Caliper Disassembly

- Refer to the Caliper Rubber Parts Replacement in the Periodic Maintenance chapter.

## Calipers

### Front Caliper Assembly

- Refer to the Caliper Rubber Parts Replacement in the Periodic Maintenance chapter.

### Rear Caliper Disassembly

- Refer to the Caliper Rubber Parts Replacement in the Periodic Maintenance chapter.

### Rear Caliper Assembly

- Refer to the Caliper Rubber Parts Replacement in the Periodic Maintenance chapter.

### Caliper Fluid Seal Damage Inspection

The fluid seals (piston seals) [A] are placed around the piston to maintain clearance between the pad and the disc. If the seal is in a poor condition, it could lead the pad to wear excessively or the brake to drag, which may cause the temperature of the discs or the brake fluid to increase.

- Replace the fluid seal if it exhibits any of the conditions listed below.
  - Brake fluid leakage around the pad.
  - Brakes overheat.
  - Considerable difference in inner and outer pad wear.
  - Seal and piston are stuck together.
- ★ If the fluid seal is replaced, replace the dust seal [B] as well. Also, replace all seals every other time the pads are changed.

Front Caliper [C]

Rear Caliper [D]

### Caliper Dust Seal Damage Inspection

- Check that the dust seals [A] are not cracked, worn, swollen, or otherwise damaged.
- ★ If they show any damage, replace the dust seals with new ones.

Pistons [B]

Fluid Seals [C]

Front Caliper [D]

Rear Caliper [E]

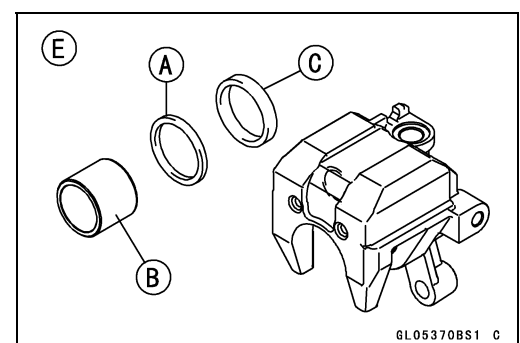
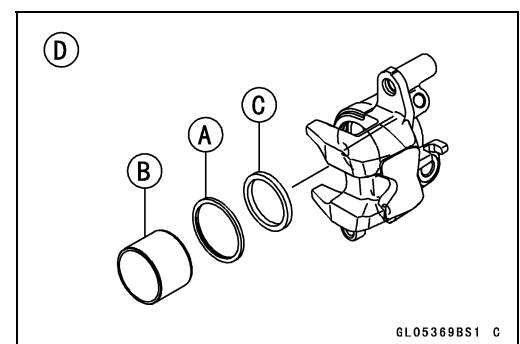
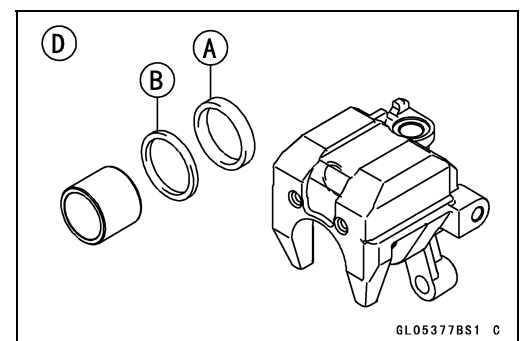
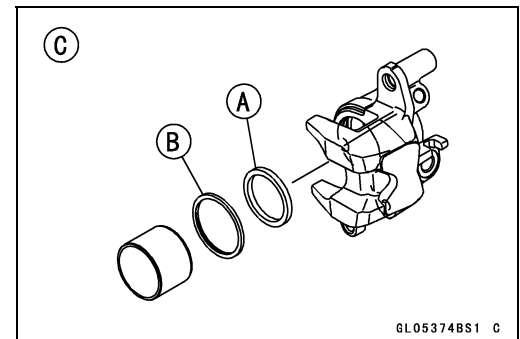

# 11-12 BRAKES

## Calipers

### Caliper Boots Inspection

- Check that the dust boots [A] and friction boots [B] are not cracked, worn, swollen, or otherwise damaged.
- ★ If they show any damage, replace it.
  - Front Caliper [C]
  - Rear Caliper [D]

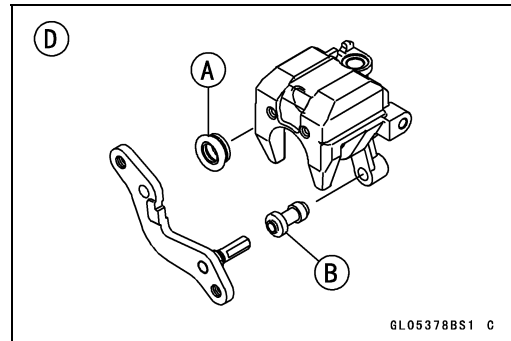
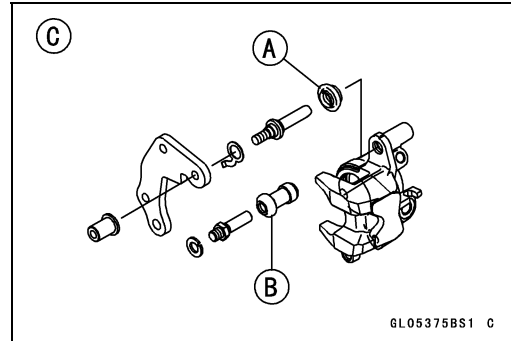

### Caliper Piston and Cylinder Damage Inspection

- Visually inspect the pistons [A] and cylinder surfaces.
- ★ Replace the caliper if the cylinder and piston are badly scored or rusty.
  - Front Caliper [B]
  - Rear Caliper [C]

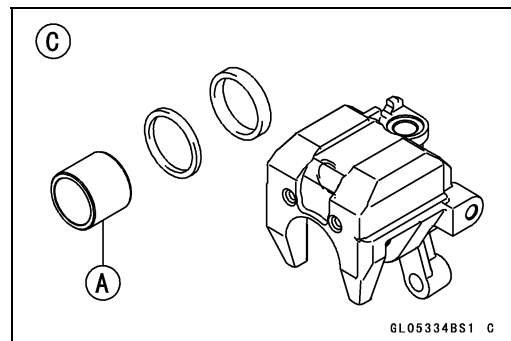
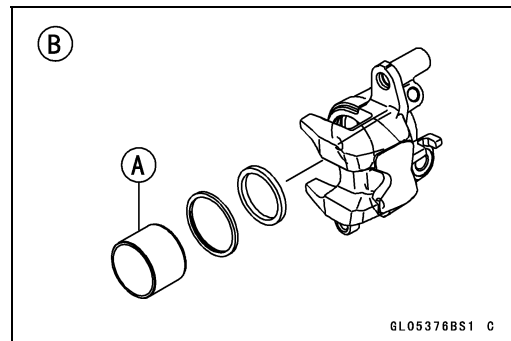

## Calipers

### Caliper Holder Pin Inspection

The caliper body must slide smoothly on the caliper holder pins [A]. If the body does not slide smoothly, one pad will wear more than the other, pad wear will increase, and constant drag on the disc will raise brake and brake fluid temperature.

- Check to see that the caliper holder pins are not badly worn or stepped, and that the rubber friction boots are not damaged.
- ★ If the caliper holder pin is damage, replace the caliper holder or holder pin.

**Torque - Front Caliper Holder Pin: 17.2 N·m (1.75 kgf·m, 12.7 ft·lb)**

- Apply a non-permanent locking agent to the threads of the front caliper holder pin nut [B].

**Torque - Front Caliper Holder Pin Nut: 22.1 N·m (2.25 kgf·m, 16.3 ft·lb)**

- Apply silicone grease to the caliper holder pins.
- Apply a non-permanent locking agent to the threads of the rear caliper holder pin [C] and screw it with the conical spring washer [D] to the rear caliper holder.
- Install the washer to the rear caliper holder pin so that the tapered side [E] faces caliper holder.

**Torque - Rear Caliper Holder Pin: 17.2 N·m (1.75 kgf·m, 12.7 ft·lb)**

- Apply silicone grease to the groove on the rear caliper holder pin.

Front Caliper [F]  
Rear Caliper [G]

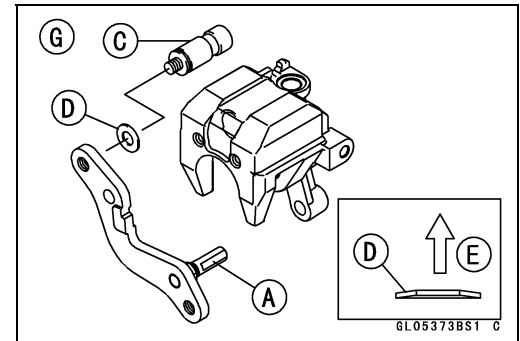
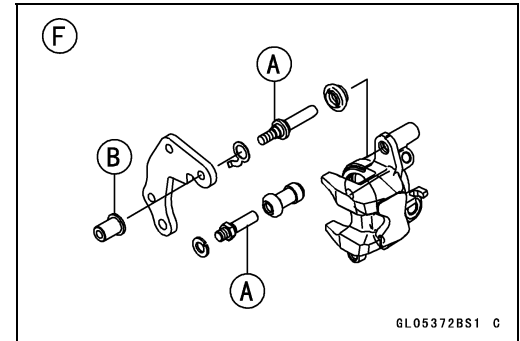

## 11-14 BRAKES

### Brake Pad

#### **Front Brake Pad Removal**

- Push the caliper [A] toward the brake disc to increase a clearance between the brake pads and disc.
- To prevent flow out the brake fluid from the master cylinder, do not push the caliper more than necessary.
- Remove the pad pin plug [B] and loosen the pad pin [C].
- Remove the caliper mounting bolts [D].
- Remove the caliper from the disc with the hose connected.

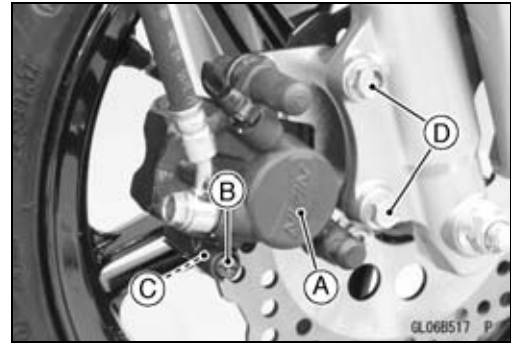

- Remove the pad pin [A] and brake pads [B].

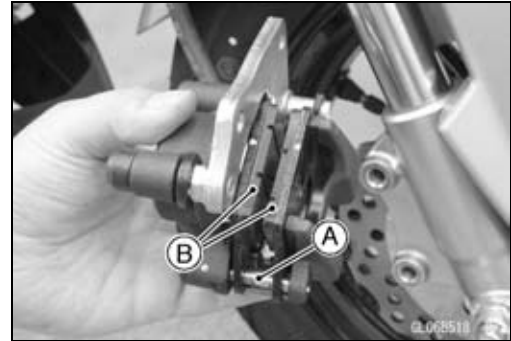

#### **Front Brake Pad Installation**

- Make sure that the anti-rattle spring [A] is in its correct position.

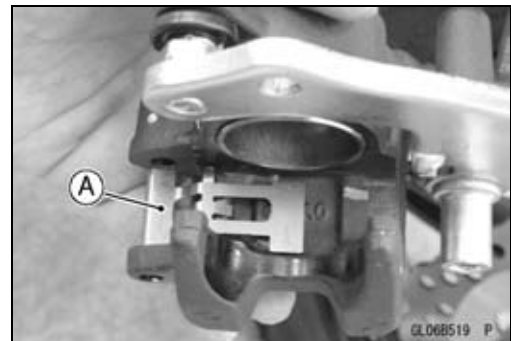

- Install the brake pads [A] with the piston side first, then install the other side.
- Tighten the brake pad pin [B] temporary.

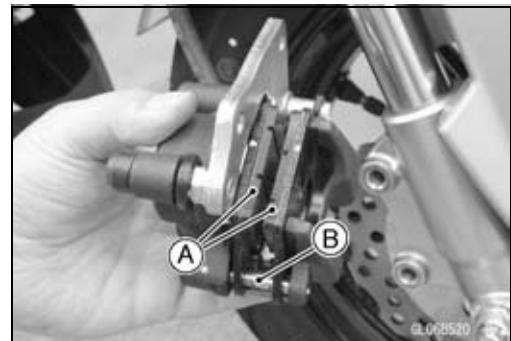



## Brake Pad

- Install the front brake caliper [A] to the front fork.
- Tighten:
  - Torque - Front Caliper Mounting Bolts [B]: 25 N·m (2.5 kgf·m, 18 ft·lb)
  - Front Caliper Pad Pin [C]: 17.2 N·m (1.75 kgf·m, 12.7 ft·lb)
  - Front Caliper Pad Pin Plug [D]: 2.5 N·m (0.25 kgf·m, 22 in·lb)

### WARNING

After servicing, it takes several applications of the brake lever before the brake pads contact the disc, which could result in increased stopping distance and cause an accident resulting in injury or death. Do not attempt to ride the motorcycle until a firm brake lever is obtained by pumping the lever until the pads are against the disc.

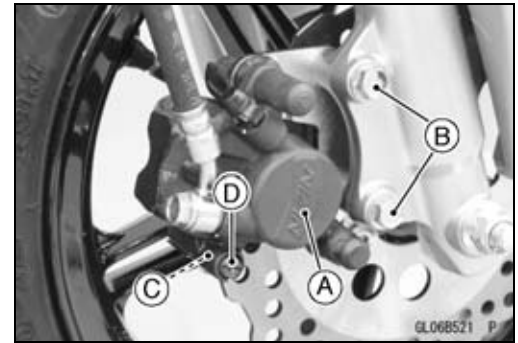

### Rear Brake Pad Removal

- Push the caliper [A] toward the brake disc to increase a clearance between the brake pads and disc.
  - To prevent flow out the brake fluid from the master cylinder, do not push the caliper more than necessary.
  - Loosen the pad pins [B].
  - Remove the caliper mounting bolts [C].
  - Remove the caliper from the disc with the hose connected.
- 
- Remove the pad pins [A] and brake pads [B].

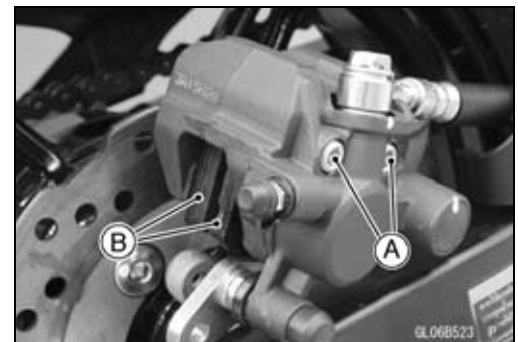
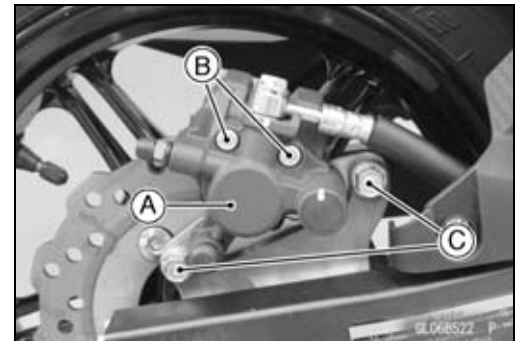

### Rear Brake Pad Installation

- Make sure that the anti-rattle spring [A] is in its correct position.



## 11-16 BRAKES

### Brake Pad

- Install the brake pads [A] with the piston side first, then install the other side.
- Tighten the brake pad pins [B] temporary.

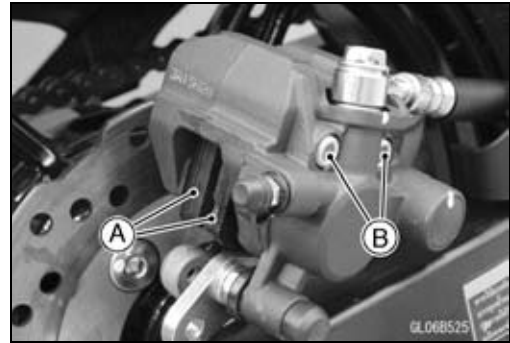

- Install the rear brake caliper [A] to the caliper bracket.
- Tighten:
  - Torque - Rear Caliper Mounting Bolts [B]: 25 N·m (2.5 kgf·m, 18 ft·lb)
  - Rear Caliper Pad Pins [C]: 17.2 N·m (1.75 kgf·m, 12.7 ft·lb)

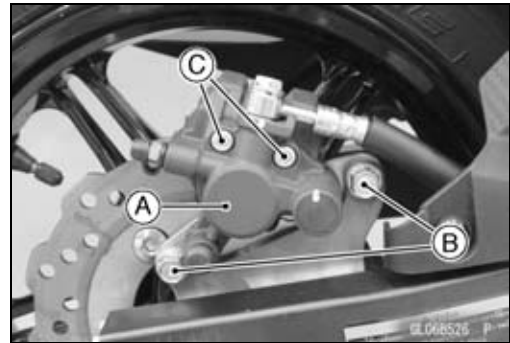

#### **⚠ WARNING**

After servicing, it takes several applications of the brake pedal before the brake pads contact the disc, which could result in increased stopping distance and cause an accident resulting in injury or death. Do not attempt to ride the motorcycle until a firm brake pedal is obtained by pumping the pedal until the pads are against the disc.

#### ***Brake Pad Wear Inspection***

- Refer to the Brake Pad Wear Inspection in the Periodic Maintenance chapter.

## Master Cylinder

### Front Master Cylinder Removal

- Remove the brake hose banjo bolt [A] to disconnect the brake hose from the master cylinder.
- Remove the clamp bolts [B] and remove the master cylinder [C] with the reservoir, brake lever, and front brake light switch as an assembly.
- Disconnect the front brake light switch connectors [D].

#### NOTICE

**Brake fluid quickly damages painted plastic surfaces; any spilled fluid should be completely washed away immediately.**

### Front Master Cylinder Installation

- Connect the front brake light switch connectors.
- Set the front master cylinder to match its mating surface [A] to the punch mark [B] of the handlebar.
- The master cylinder clamp must be installed with the arrow mark [C] upward.
- Tighten the upper clamp bolt first, and then the lower clamp bolt.

**Torque - Front Master Cylinder Clamp Bolts: 8.8 N·m (0.90 kgf·m, 78 in·lb)**

- Replace the washers that are on each side of the hose fitting with new ones.
- Connect the brake hose [A] to the master cylinder [B] with washers.
- Fit the brake hose to the stopper [C] on the master cylinder.
- Tighten:

**Torque - Brake Hose Banjo Bolt [D]: 25 N·m (2.5 kgf·m, 18 ft·lb)**

- Bleed the brake line (see Brake Line Bleeding).
- Check the brake for good braking power, no brake drag, and no fluid leakage.

### Rear Master Cylinder Removal

- Remove:
  - Brake Pedal (see Brake Pedal Removal)
  - Reservoir Mounting Bolt [A]
- Free the reservoir hose [B] from the clamps [C].

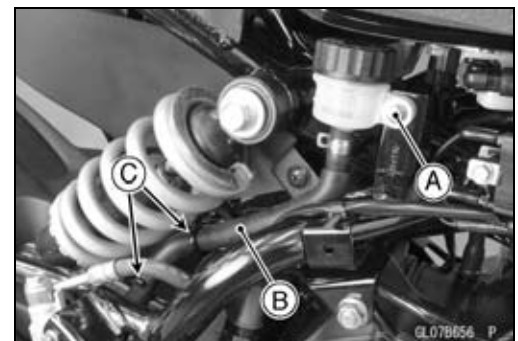
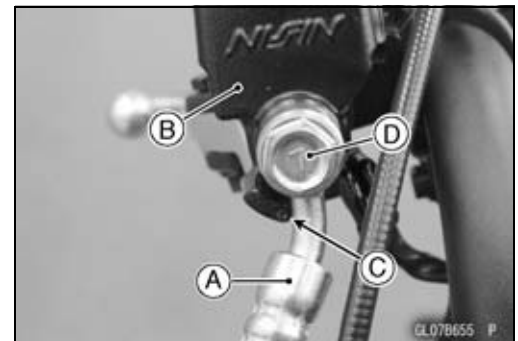
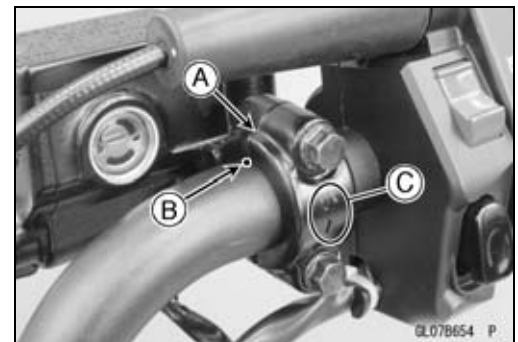
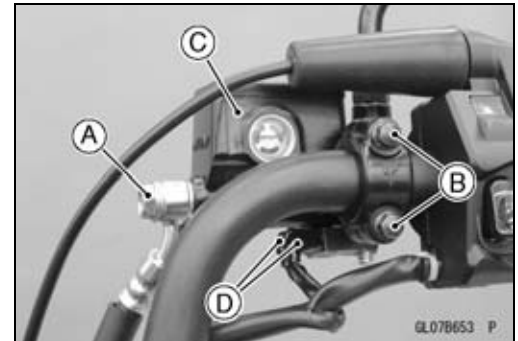

## 11-18 BRAKES

### Master Cylinder

- Remove the brake hose banjo bolt [A] to disconnect the brake hose from the rear master cylinder.
- Remove the rear master cylinder mounting bolts [B].

#### **NOTICE**

**Brake fluid quickly damages painted plastic surfaces; any spilled fluid should be completely washed away immediately.**

- Slide the clamp [A] and disconnect the reservoir hose [B] from the rear master cylinder [C].
- Drain the brake fluid into a container.

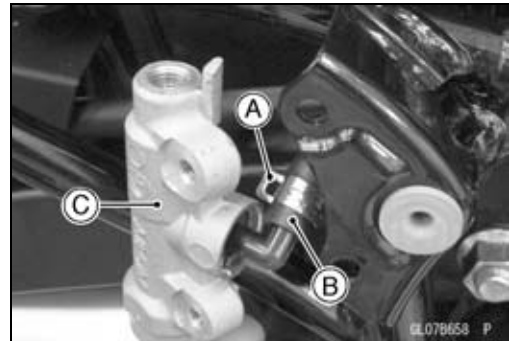
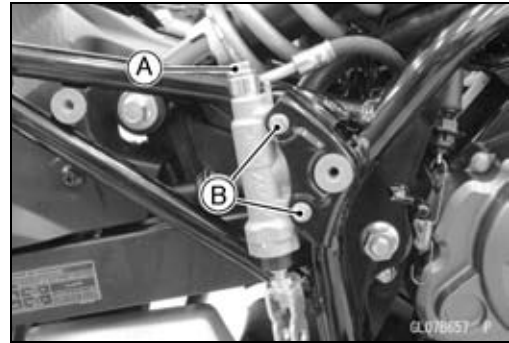

#### **Rear Master Cylinder Installation**

- Connect the reservoir hose [A] to the rear master cylinder [B] and hold it with the clamp [C].

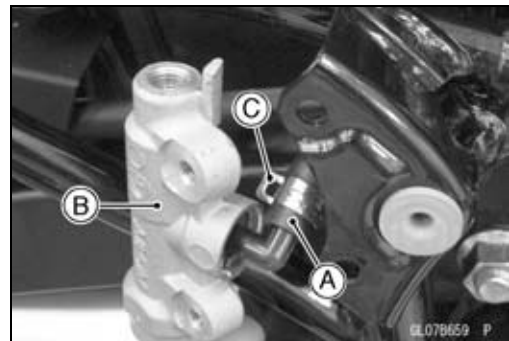

- Replace the washers on each side of hose fitting with new ones.
- Connect the brake hose [A] to the rear master cylinder with washers and loosely install the brake hose banjo bolt [B].
- Tighten:

**Torque - Rear Master Cylinder Mounting Bolts [C]: 8.8 N·m (0.90 kgf·m, 78 in·lb)**

**Brake Hose Banjo Bolt: 25 N·m (2.5 kgf·m, 18 ft·lb)**

- Run the reservoir hose correctly (see Cable, Wire, and Hose Routing section in the Appendix chapter).
- Install the reservoir mounting bolt.
- Install the rear brake pedal (see Brake Pedal Installation).
- Bleed the brake line (see Brake Line Bleeding).
- Check the brake for good braking power, no brake drag, and no fluid leakage.

#### **Front Master Cylinder Disassembly**

- Refer to the Master Cylinder Rubber Parts Replacement in the Periodic Maintenance chapter.

#### **Rear Master Cylinder Disassembly**

- Refer to the Master Cylinder Rubber Parts Replacement in the Periodic Maintenance chapter.

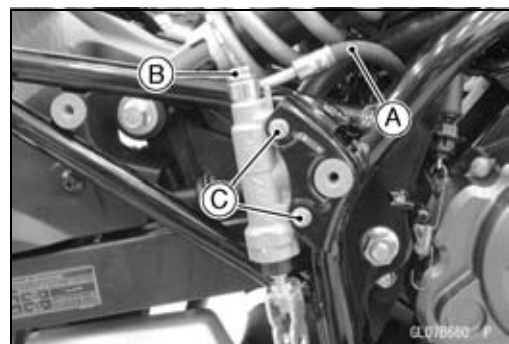

## Master Cylinder

### Master Cylinder Assembly

- Refer to the Master Cylinder Rubber Parts Replacement in the Periodic Maintenance chapter.

### Master Cylinder Inspection

- Remove the master cylinders (see Front/Rear Master Cylinder Removal).
- Disassemble the front and rear master cylinders (see Master Cylinder Rubber Parts Replacement in the Periodic Maintenance chapter).
- Check that there are no scratches, rust or pitting on the inner wall [A] of each master cylinder and on the outside of each piston [B].
- ★ If a master cylinder or piston shows any damage, replace them.
- Inspect the primary cups [C] and secondary cups [D].
- ★ If the cups are worn, damaged softened (rotted), or swollen, the piston assembly should be replaced to renew the cups.
- ★ If fluid leakage is noted at the brake lever, the piston assembly should be replaced to renew the cups.
- Check the dust covers [E] for damage.
- ★ If they are damaged, replace them.
- Check the piston return springs [F] for any damage.
- ★ If the springs are damaged, replace them.
- Check that relief port [G] and supply port [H] are not plugged.
- ★ If the relief port becomes plugged, the brake pads will drag on the disc. Blow the ports clean with compressed air.

Front Master Cylinder [J]

Rear Master Cylinder [K]

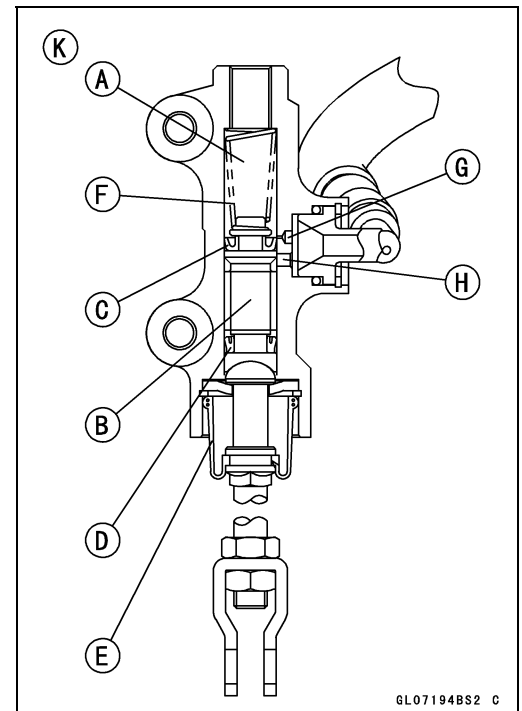
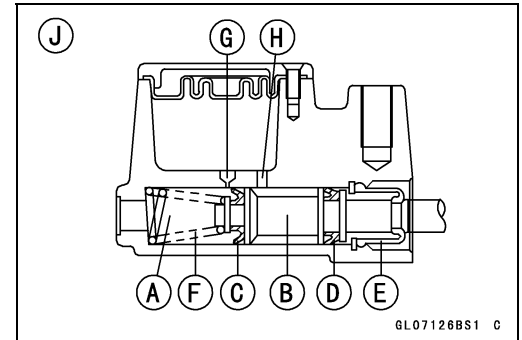

# 11-20 BRAKES

## Brake Disc

### Brake Disc Removal

- Remove the wheels (see Front/Rear Wheel Removal in the Wheels/Tires chapter).
- Remove:
  - Brake Disc Mounting Bolts [A]
  - Brake Disc [B]
  - Gasket (Front only)

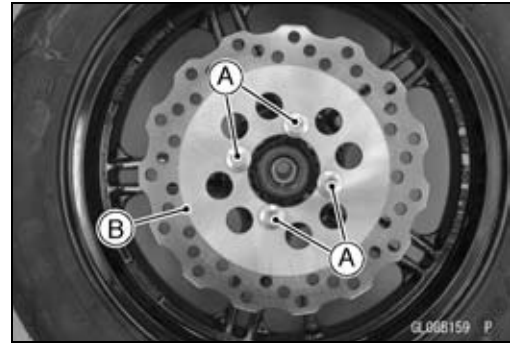

### Brake Disc Installation

- For the front brake disc, replace the gasket with a new one.
- Install the brake disc on the wheel so that the marked side [A] faces out.
- Apply a non-permanent locking agent to the threads of the front and rear brake disc mounting bolts [B], and tighten them alternating diagonally.

**Torque - Brake Disc Mounting Bolts: 27 N·m (2.8 kgf·m, 20 ft·lb)**

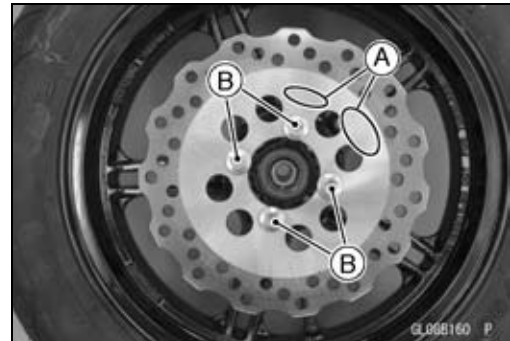

### Brake Disc Wear Inspection

- Measure the thickness of each disc [A] at the point where it has worn the most.
  - ★ If the disc has worn past the service limit, replace it.
- Measuring Area [B]

#### Brake Disc Thickness

##### Standard:

Front	3.3 ~ 3.7 mm (0.13 ~ 0.15 in.)
Rear	3.8 ~ 4.2 mm (0.15 ~ 0.17 in.)

##### Service Limit:

Front	3.0 mm (0.12 in.)
Rear	3.5 mm (0.14 in.)

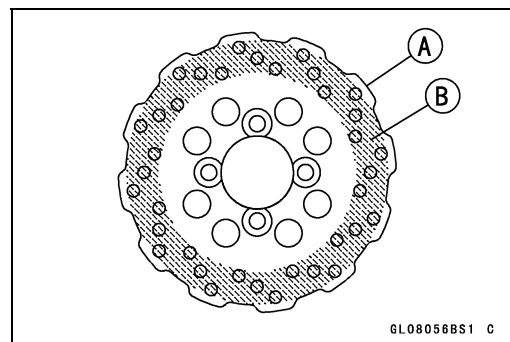

### Brake Disc Warp Inspection

- Raise the front/rear wheel off the ground.
- Special Tool - Jack: 57001-1238**  
**Jack Attachment: 57001-1608**
- For front disc inspection, turn the handlebar fully to one side.
  - Set up a dial gauge against the disc [A] as shown and measure disc runout, while turning [B] the wheel by hand.
  - ★ If runout exceeds the service limit, replace the disc.

#### Disc Runout

Standard:	TIR 0.2 mm (0.008 in.) or less
Service Limit:	TIR 0.3 mm (0.01 in.)

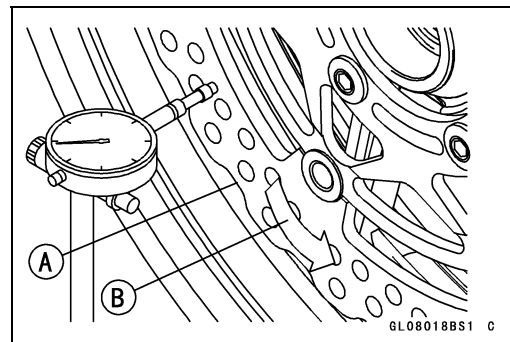

---

## Brake Fluid

---

### ***Brake Fluid Level Inspection***

- Refer to the Brake Fluid Level Inspection in the Periodic Maintenance chapter.

### ***Brake Fluid Change***

- Refer to the Brake Fluid Change in the Periodic Maintenance chapter.

### ***Brake Line Bleeding***

The brake fluid has a very low compression coefficient so that almost all the movement of the brake lever or pedal is transmitted directly to the caliper for braking action. Air, however, is easily compressed. When air enters the brake lines, brake lever or pedal movement will be partially used in compressing the air. This will make the lever or pedal feel spongy, and there will be a loss in braking power.

 <b>WARNING</b>
--

<p><b>Air in the brake lines diminish braking performance and can cause an accident resulting in injury or death. If the brake lever or pedal has a soft or "spongy" feeling mushy when it is applied, there might be air in the brake lines or the brake may be defective. Do not operate the vehicle and service the brake system immediately.</b></p>
--

<b>NOTICE</b>
---------------

<p><b>Brake fluid quickly damages painted plastic surfaces; any spilled fluid should be completely washed away immediately.</b></p>
---

### **NOTE**

- *The procedure to bleed the front brake line is as follows. Bleeding the rear brake line is the same as for the front brake.*

## 11-22 BRAKES

### Brake Fluid

- Remove:
  - Front Reservoir Cap
  - Front Diaphragm
- For the rear brake system followings.
  - Right Side/Frame Cover (see Side/Frame Cover Removal in the Frame chapter)
  - Rear Brake Fluid Reservoir Mounting Bolt
  - Rear Reservoir Cap
  - Rear Diaphragm
- Fill the reservoir [A] with fresh brake fluid to the upper level line [B] in the reservoir.
  - Front Brake Reservoir [C]
  - Rear Brake Reservoir [D]

#### Brake Fluid Grade

Front: DOT3 or DOT4

Rear: DOT3

#### NOTE

- *Keep the reservoir horizontally whenever add brake fluid to the reservoir.*
- *Be careful not to tip over the reservoir while bleeding the brake system.*
- Slowly pump the brake lever several times until no air bubbles can be seen rising up through the fluid from the holes at the bottom of the reservoir.
- Bleed the air completely from the master cylinder by this operation.
- Remove the rubber cap from the bleed valve [A] on the caliper.
- Attach a clear plastic hose [B] to the bleed valve, and run the other end of the hose into a container.

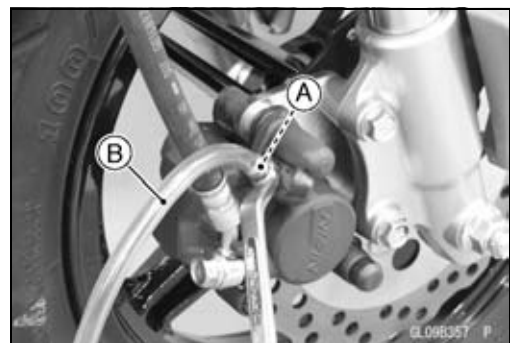
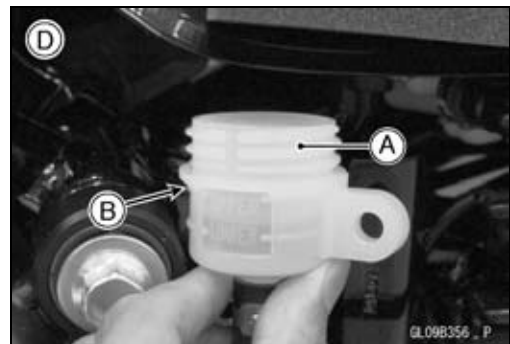
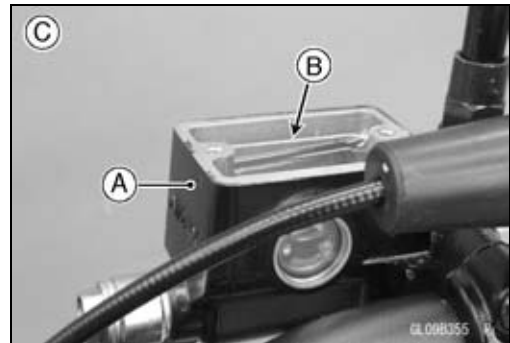



## Brake Fluid

- Bleed the brake line and the caliper.
- Repeat this operation until no more air can be seen coming out into the plastic hose.
- 1. Pump the brake lever until it becomes hard, and apply the brake and hold it [A].
- 2. Quickly open and close [B] the bleed valve while holding the brake applied.
- 3. Release the brake [C].

### NOTICE

**After pumping the brake lever several times, releasing it without opening and closing of the bleed valve may cause brake fluid to be blown back from the master cylinder reservoir. Brake fluid spilt on painted surfaces and plastic parts will quickly damage them. Be sure to open and close the bleed valve.**

### NOTE

- The fluid level must be checked often during the bleeding operation and replenished with fresh brake fluid as necessary. If the fluid in the reservoir runs completely out any time during bleeding, the bleeding operation must be done over again from the beginning since air will have entered the line.
  - Tap the brake hose lightly from the caliper to the reservoir for more complete bleeding.
- Remove the clear plastic hose.
  - Tighten the bleed valve [A], and install the rubber cap [B].  
**Torque - Bleed Valve: 7.8 N·m (0.80 kgf·m, 69 in·lb)**
  - Check the fluid level (see Brake Fluid Level Inspection in the Periodic Maintenance chapter).

- Install the diaphragm and reservoir cap [A].
- Tighten:  
**Torque - Front Brake Reservoir Cap Screws [B]: 1.5 N·m (0.15 kgf·m, 13 in·lb)**

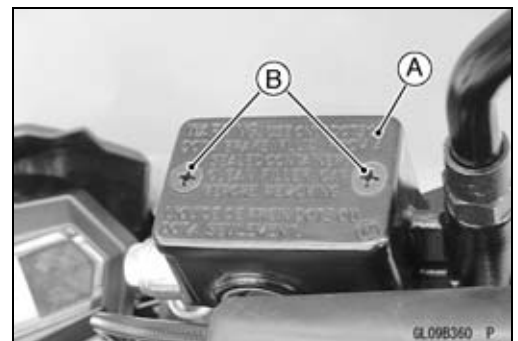
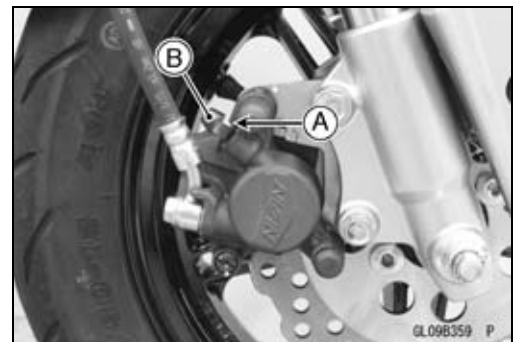
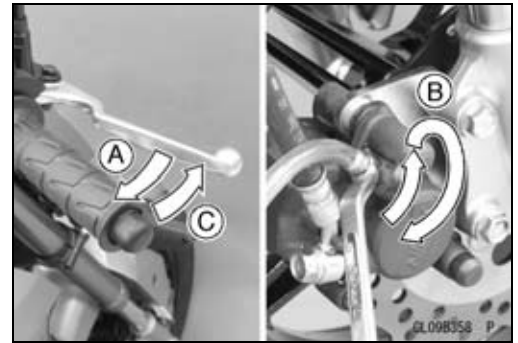

## 11-24 BRAKES

### Brake Fluid

- Follow the procedure below to install the rear brake fluid reservoir cap correctly.

○ First, tighten the rear brake fluid reservoir cap [A] clockwise [B] by hand until slight resistance is felt indicating that the cap is seated on the reservoir body [C], then tighten the cap an additional 1/6 turn [D] while holding the brake fluid reservoir body.

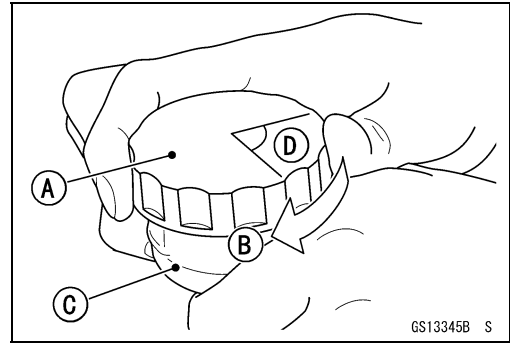

- Install the rear brake fluid reservoir [A].
- Tighten the rear brake fluid reservoir mounting bolt [B].
- After bleeding is done, check the brake for good braking power, no brake drag, and no fluid leakage.
- Install the right side/frame cover (see Side/Frame Cover Installation in the Frame chapter).

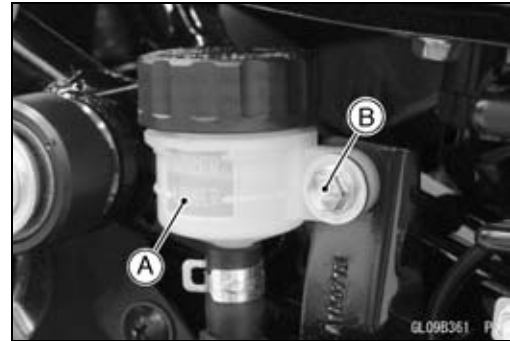

---

**Brake Fluid**

---

** WARNING**

When working with the disc brake, observe the precautions listed below.

- Never reuse old brake fluid.
- Do not use fluid from a container that has been left unsealed or that has been open for a long time.
- Do not mix two types and brands of fluid for use in the brake. This lowers the brake fluid boiling point and could cause the brake to be ineffective. It may also cause the rubber brake parts to deteriorate.
- Don't leave the reservoir cap off for any length of time to avoid moisture contamination of the fluid.
- Don't change the fluid in the rain or when a strong wind is blowing.
- Except for the disc pads and disc, use only disc brake fluid, isopropyl alcohol, or ethyl alcohol for cleaning of the brake parts. Do not use any other fluid for cleaning these parts. Gasoline, engine oil, or any other petroleum distillate will cause deterioration of the rubber parts. Oil spilled on any part will be difficult to wash off completely and will eventually deteriorate the rubber used in the disc brake.
- When handling the disc pads or disc, be careful that no disc brake fluid or any oil gets on them. Clean off any fluid or oil that inadvertently gets on the pads or disc with a high flash-point solvent. Do not use one which will leave an oily residue. Replace the pads with new ones if they cannot be cleaned satisfactorily.
- Brake fluid quickly damages painted surfaces; any spilled fluid should be completely wiped up immediately.
- If any of the brake line fittings or the bleed valve is opened at any time, the AIR MUST BE BLED FROM THE BRAKE LINE.

## 11-26 BRAKES

---

### Brake Hose

---

#### ***Brake Hose Removal/Installation***

- Refer to the Brake Hose and Pipe Replacement in the Periodic Maintenance chapter.

#### ***Brake Hose Inspection***

- Refer to the Brake Hose and Pipe Damage and Installation Condition Inspection in the Periodic Maintenance chapter.

# Suspension

## Table of Contents

Exploded View .....	12-2
Specifications .....	12-6
Special Tools .....	12-7
Front Fork .....	12-8
Front Fork Removal (Each Fork Leg) .....	12-8
Front Fork Installation (Each Fork Leg) .....	12-8
Front Fork Oil Change .....	12-8
Front Fork Disassembly .....	12-9
Front Fork Assembly .....	12-11
Inner Tube, Outer Tube Inspection .....	12-12
Dust Seal Inspection .....	12-12
Rear Shock Absorber .....	12-13
Spring Preload Adjustment .....	12-13
Rear Shock Absorber Removal .....	12-13
Rear Shock Absorber Installation .....	12-13
Rear Shock Absorber Inspection .....	12-13
Swingarm .....	12-14
Swingarm Removal .....	12-14
Swingarm Installation .....	12-14
Swingarm Sleeve Inspection .....	12-15
Swingarm Bushing Removal .....	12-15
Swingarm Bushing Installation .....	12-15
Swingarm Bushing Inspection .....	12-16

# 12-2 SUSPENSION

## Exploded View

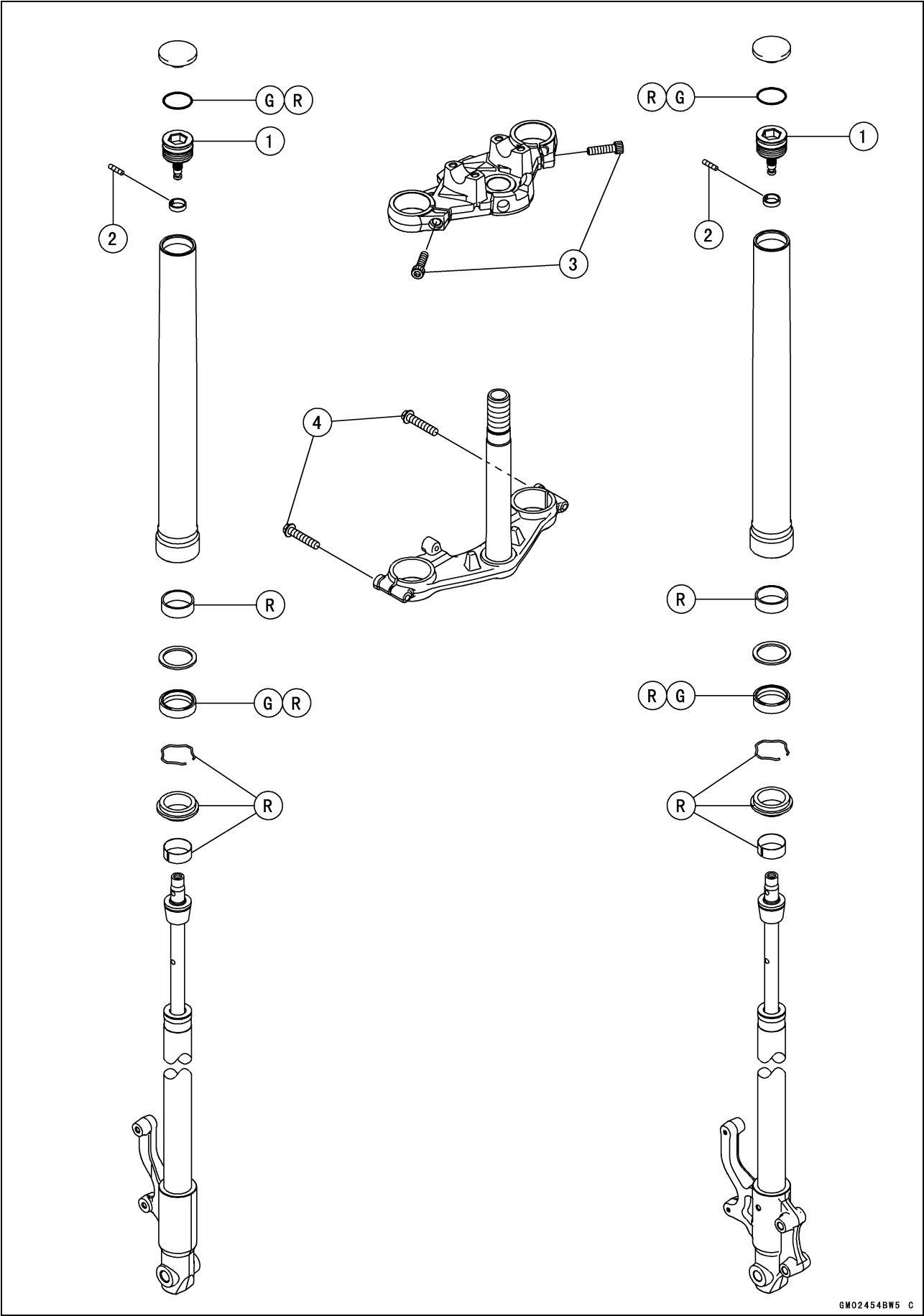

**Exploded View**

No.	Fastener	Torque			Remarks
		N·m	kgf·m	ft·lb	
1	Front Fork Top Plugs (for Outer Tube)	22.5	2.29	16.6	
	Front Fork Top Plugs (for Cylinder Unit)	23	2.3	17	
2	Set Screws	1.4	0.14	12 in·lb	
3	Front Fork Clamp Bolts (Upper)	20	2.0	15	
4	Front Fork Clamp Bolts (Lower)	20	2.0	15	

G: Apply grease.

R: Replacement Parts

# 12-4 SUSPENSION

## Exploded View

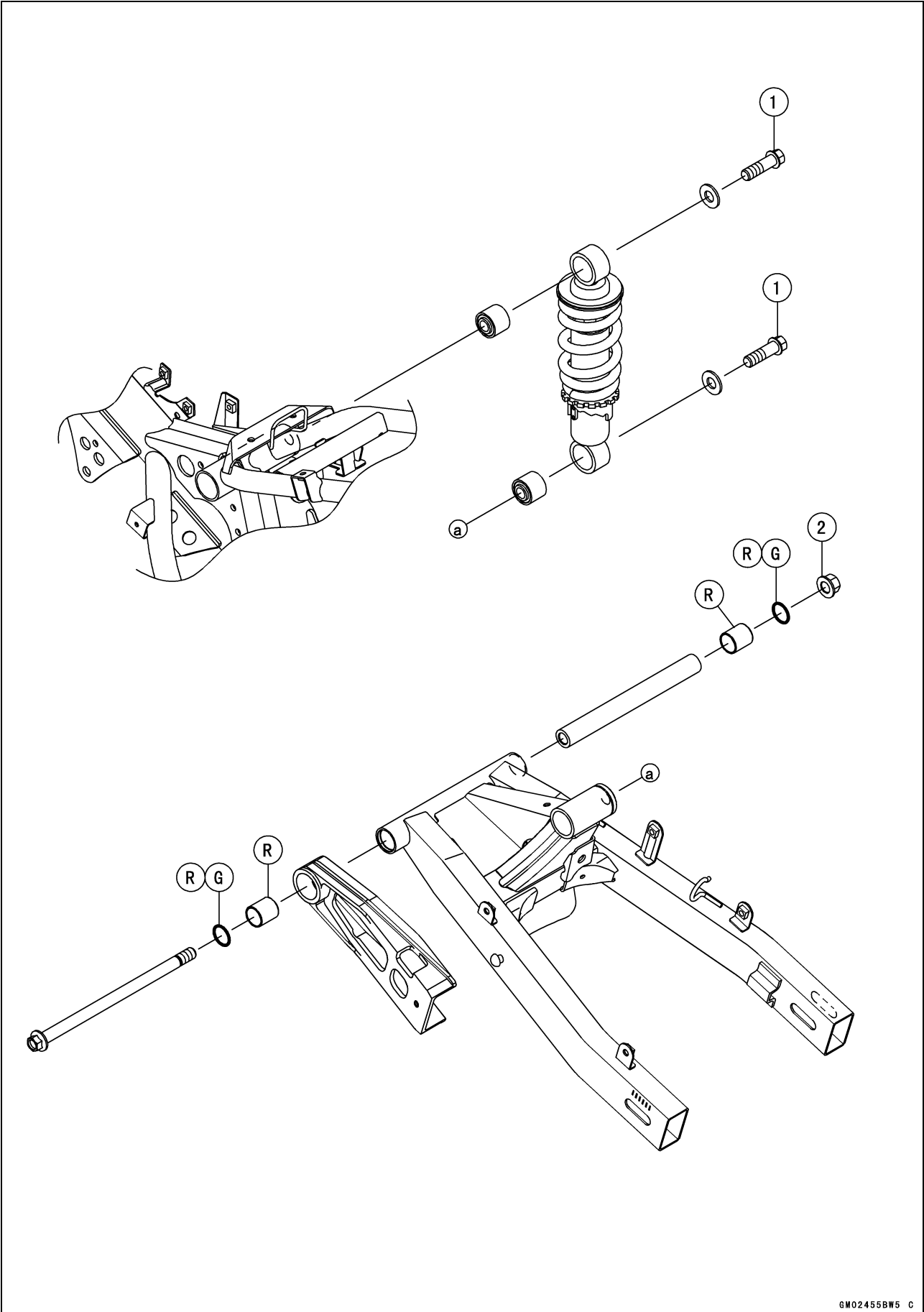



**Exploded View**

<b>No.</b>	<b>Fastener</b>	<b>Torque</b>			<b>Remarks</b>
		<b>N·m</b>	<b>kgf·m</b>	<b>ft·lb</b>	
1	Rear Shock Absorber Bolts	59	6.0	44	
2	Swingarm Pivot Shaft Nut	88	9.0	65	

G: Apply grease.

R: Replacement Parts

## 12-6 SUSPENSION

### Specifications

Item	Standard	Service Limit
<b>Front Fork (Per One Unit)</b>		
Fork Inner Tube Diameter	$\phi$ 30 mm (1.2 in.)	---
Air Pressure	Atmospheric pressure (Non-adjustable)	---
Suspension Oil	Kawasaki G10 or equivalent	---
Amount:		
When changing oil	Approx. 185 mL (6.25 US oz.)	---
After disassembly and completely dry	216 $\pm$ 3 mL (7.30 $\pm$ 0.10 US oz.)	---
Fork Spring Free Length	364 mm (14.3 in.)	357 mm (14.1 in.)
<b>Rear Shock Absorber</b>		
Spring Preload Setting Position:		
Standard	2nd position (Adjustable Range) 1st ~ 4th position	---

Special Tools

Oil Seal & Bearing Remover:  
57001-1058

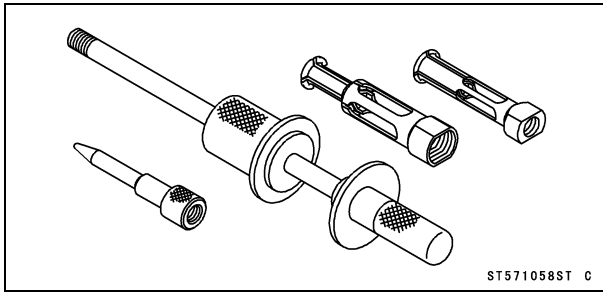

Jack Attachment:  
57001-1608

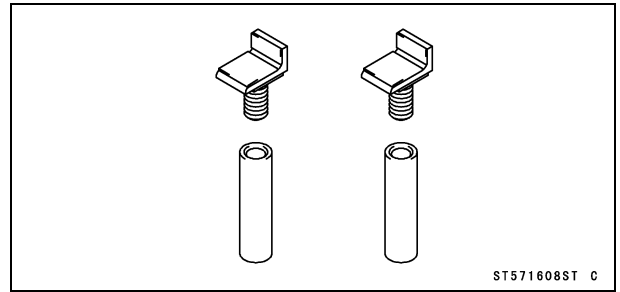

Steering Stem Nut Wrench:  
57001-1100

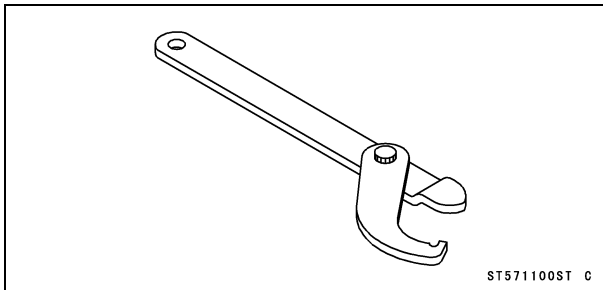

Needle Bearing Driver,  $\phi 17/\phi 18$ :  
57001-1609

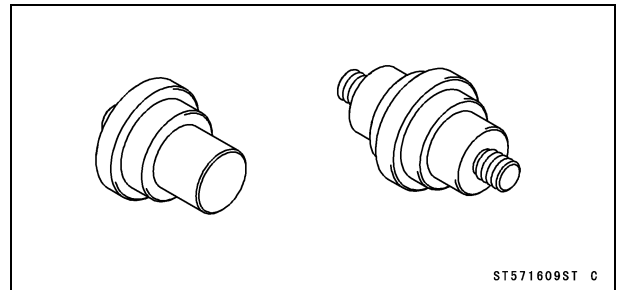

Bearing Driver Set:  
57001-1129

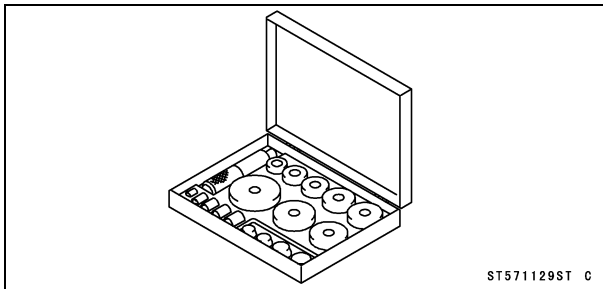

Spacer:  
57001-1790

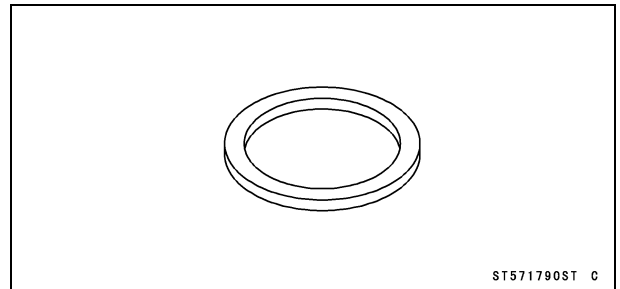

Jack:  
57001-1238

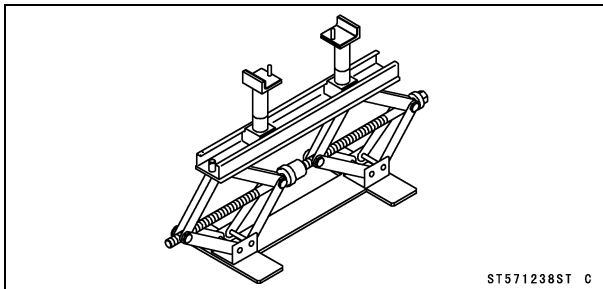

Fork Oil Seal Driver Weight,  $\phi 26 \sim \phi 46$ :  
57001-1795

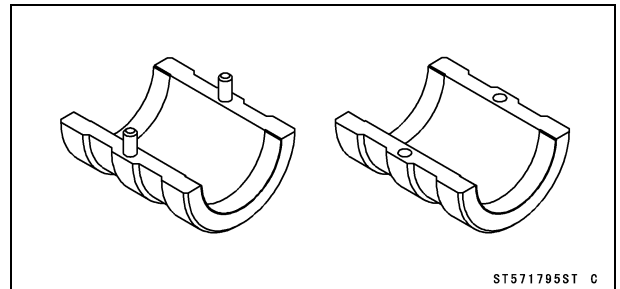

Fork Oil Seal Driver,  $\phi 30$ :  
57001-1337

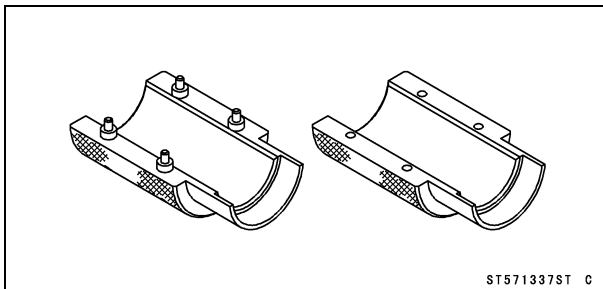

Fork Oil Seal Driver Attachment,  $\phi 26 \sim \phi 36$ :  
57001-1797

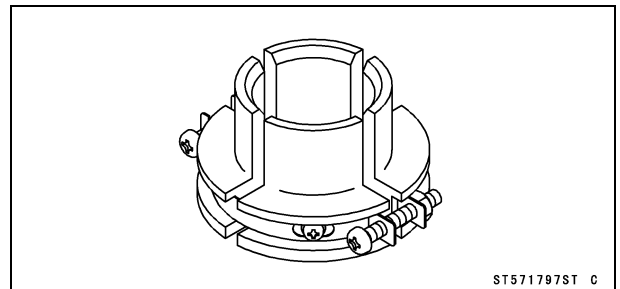

## 12-8 SUSPENSION

### Front Fork

#### **Front Fork Removal (Each Fork Leg)**

- ★ If disassemble the front fork, loosen the front fork top plug (for Outer Tube) before removing the front fork (see Front Fork Oil Change).
- Remove:
  - Front Wheel (see Front Wheel Removal in the Wheels/Tires chapter)
  - Front Fender (see Front Fender Removal in the Frame chapter)
- Remove the rubber cap [A].
- Loosen the front fork clamp bolt (upper) [B] and front fork clamp bolt (lower) [C].
- With a twisting motion, remove the fork leg down and out.

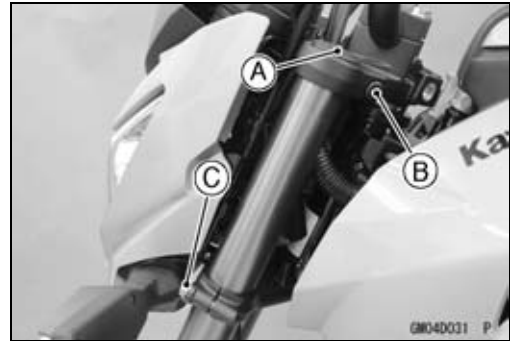

#### **Front Fork Installation (Each Fork Leg)**

- Install the front fork [A] so that the outer tube top [B] is flush with the steering stem head [C].
- Tighten:
  - Torque - Front Fork Clamp Bolts (Upper) [D]: 20 N·m (2.0 kgf·m, 15 ft·lb)
  - Front Fork Clamp Bolts (Lower) [E]: 20 N·m (2.0 kgf·m, 15 ft·lb)
- Tighten the front fork top plug if necessary.
  - Torque - Front Fork Top Plug (for Outer Tube): 22.5 N·m (2.29 kgf·m, 16.6 ft·lb)
- Install the rubber cap [F].
- Install the removed parts (see appropriate chapters).

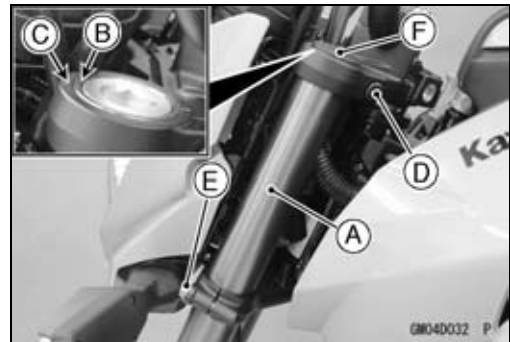

#### **Front Fork Oil Change**

- Remove the front fork (see Front Fork Removal).
- Remove the top plug [A] out of the outer tube.

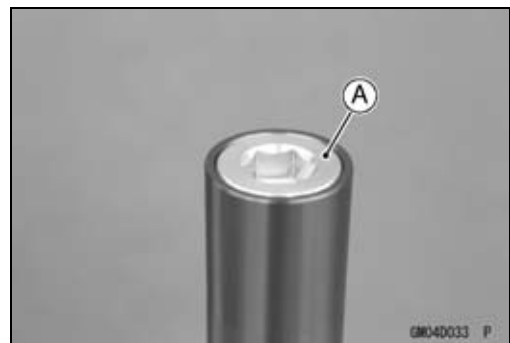

## Front Fork

- Prepare a drain pan [A] and drain the fork oil.

### NOTE

○ Pump the cylinder unit several times to drain the oil.

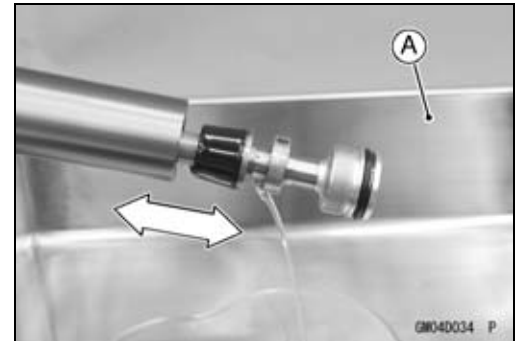

- Hold the fork tube upright, and raise the outer tube [A].
- Pour in the specified type and amount of fork oil.

**Suspension Oil - G10 (1 L): 44091-0002**

**G10 (4 L): 44091-0011**

### Amount (Per Side):

**When changing oil:**

**Approx. 185 mL (6.25 US oz.)**

**After disassembly and completely dry:**

**216 ±3 mL (7.30 ±0.10 US oz.)**

- Replace the O-ring with a new one.
- Apply grease to the O-ring.
- Install the front fork (see Front Fork Installation).



### Front Fork Disassembly

- Drain the fork oil (see Front Fork Oil Change).
- Hold the front fork in a vise.
- Loosen the set screw [A] from the ring.

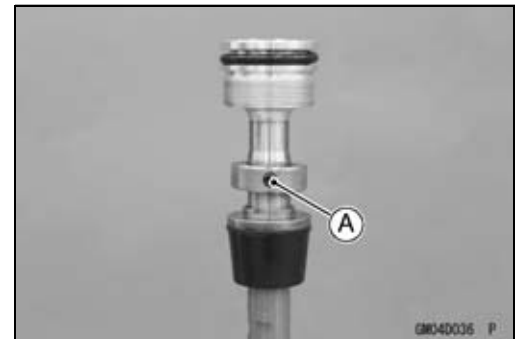

- Insert a suitable bar [A] into the 5.5 mm (0.22 in.) lower hole [B] on the cylinder [C] and hold a bar in a vise.
- While holding the cylinder, loosen the top plug [D] and remove it.

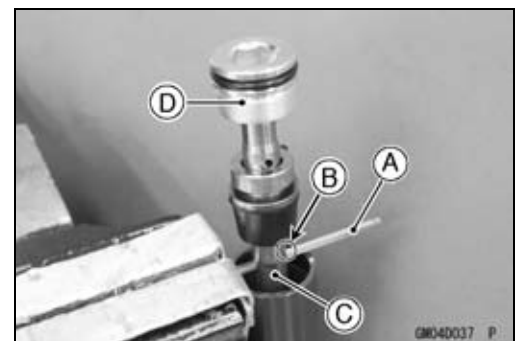

## 12-10 SUSPENSION

### Front Fork

- Remove the dust seal [A] and retaining ring [B] from outer tube.

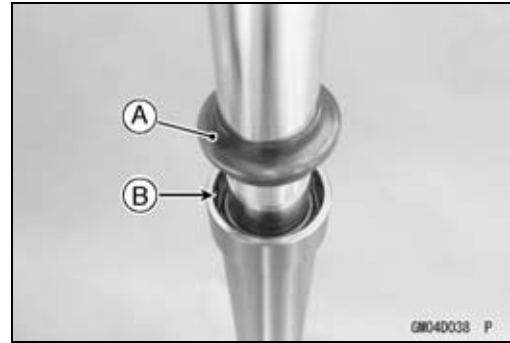

- Separate the inner tube [A] from the outer tube [B].

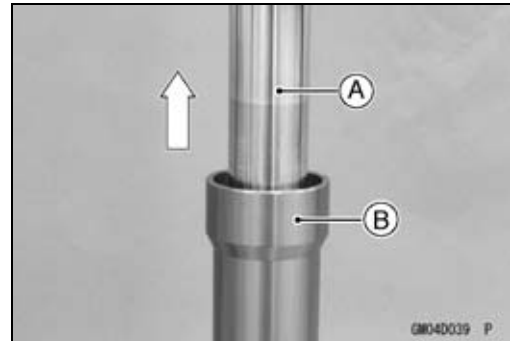

- Pump the inner tube [A] up and down [B] at least ten times to expel the oil from the inner tube.  
Cylinder Unit [C]  
Cloth [D]

#### **NOTICE**

**Be careful not to bend or damage the piston rod when the piston rod is stroked.**

- Hold the front fork at the inverted position for more than 30 minutes to allow the inner tube oil to fully drain.
- Remove the following parts from inner tube assy.  
Inner Guide Bushing [A]  
Outer Guide Bushing [B]  
Washer [C]  
Oil Seal [D]  
Retaining Ring [E]  
Dust Seal [F]

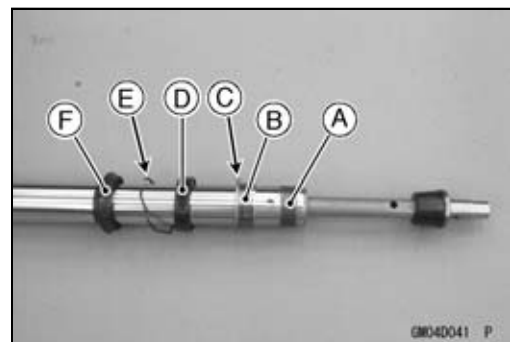
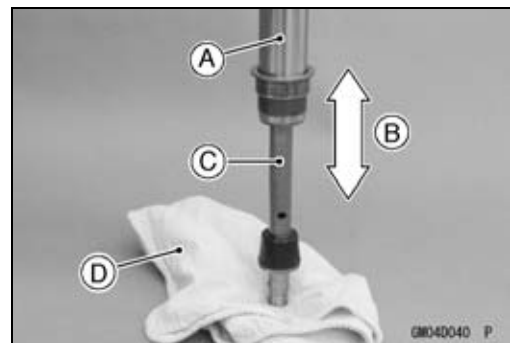

Front Fork

**Front Fork Assembly**

- Replace the following parts with new ones.
  - Inner Guide Bushing [A]
  - Outer Guide Bushing [B]
  - Oil Seal [C]
  - Retaining Ring [D]
  - Dust Seal [E]
- Place an oil coated plastic bag [F] over the end of the inner tube to protect the oil seals.
- The inner tube bushings groove has a sharp edge [G] that cut out the sealing lip of the seals as they are pushed down over the inner tube.
- Install in order these parts on the inner tube.
- Apply grease to the lips of the oil seal.
- Install the oil seal with it lip side (marked side) facing down.
- Insert the inner tube to the outer tube.
- After installing inner tube install the outer guide bushing, washer and oil seal by using the fork oil seal driver weight [A] and attachment [B] or oil seal driver.

**Special Tools - Fork Oil Seal Driver,  $\phi 30$ : 57001-1337**

**Fork Oil Seal Driver Weight,  $\phi 26 \sim \phi 46$ : 57001-1795**

**Fork Oil Seal Driver Attachment,  $\phi 26 \sim \phi 36$ : 57001-1797**

- Install the new retaining ring [A] and dust seal [B] into the outer tube.
- Raise the outer tube, pour in the specified type and amount of oil (see Front Fork Oil Change).
- After the bubbles disappeared in the outer tube, push down the outer tube until the emerged position of the cushion rubber and hold it.

**NOTICE**

**If the oil is not spread enough into the outer tube, the oil overflows when pushing down the outer tube too much.**

- Insert a suitable bar [A] into the 5.5 mm (0.22 in.) lower hole [B] on the cylinder [C] and hold a bar in a vise.
- Tighten the top plug (for cylinder unit) [D].

**Torque - Front Fork Top Plug (for Cylinder Unit): 23 N·m (2.3 kgf·m, 17 ft·lb)**

- Screw the set screw [E] on the ring [F] so that its end fit into the hole on the cylinder and tighten the set screw.

**Torque - Set Screw: 1.4 N·m (0.14 kgf·m, 12 in·lb)**

- Replace the O-ring [G] with a new one.
- Apply grease to the O-ring.
- Install the new O-ring to the top plug.
- Pull the outer tube up and screw top plug to the outer tube.
- Install the front fork (see Front Fork Installation).

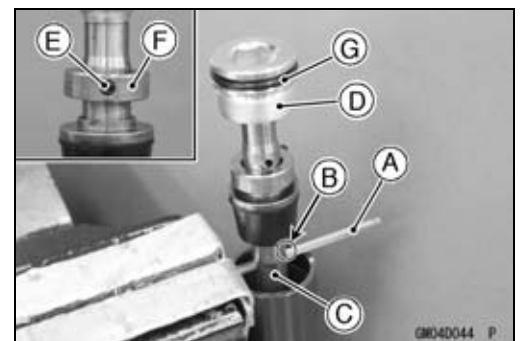
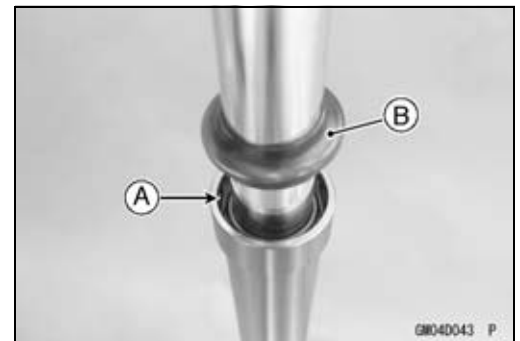
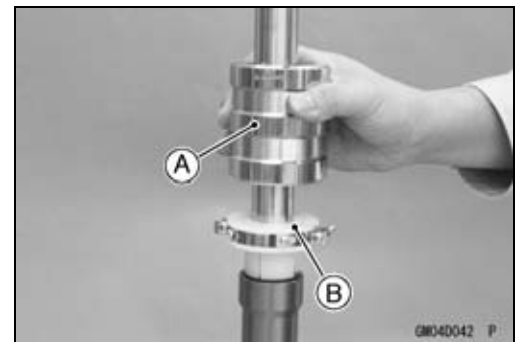
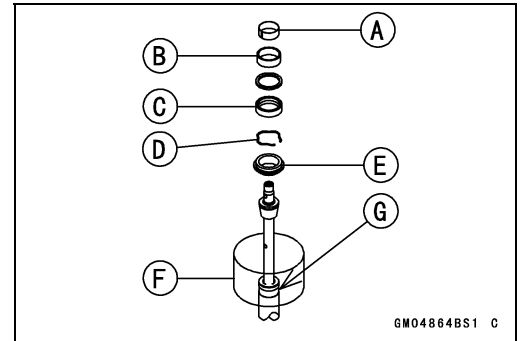

## 12-12 SUSPENSION

### Front Fork

#### *Inner Tube, Outer Tube Inspection*

- Visually inspect the inner tube [A].
- ★ If there is any damage, replace the inner tube. Since damage to the inner tube damages the oil seal and dust seal, replace the oil seal and dust seal whenever the inner tube is replaced.

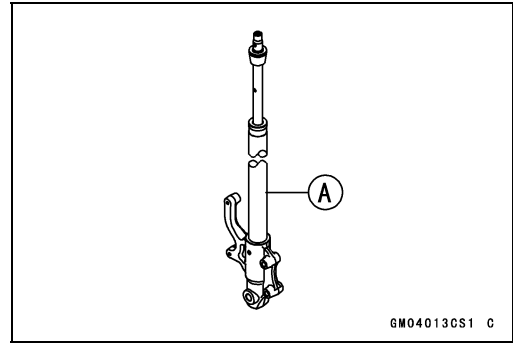

#### **NOTICE**

**If the inner tube is badly bent or creased, replace it. Excessive bending, followed by subsequent straightening, can weaken the inner tube.**

- Temporarily assemble the inner and outer tubes, and pump them back and forth manually to check for smooth operation.
- ★ If you feel binding or catching, the inner and outer tubes must be replaced.

#### **⚠ WARNING**

**A straightened inner or outer fork tube may fall in use, possibly causing an accident resulting in serious injury or death. Replace a badly bent or damaged inner or outer tube and inspect the other tube carefully before reusing it.**

#### *Dust Seal Inspection*

- Inspect the dust seals [A] for any signs of deterioration or damage.
- ★ Replace it if necessary.

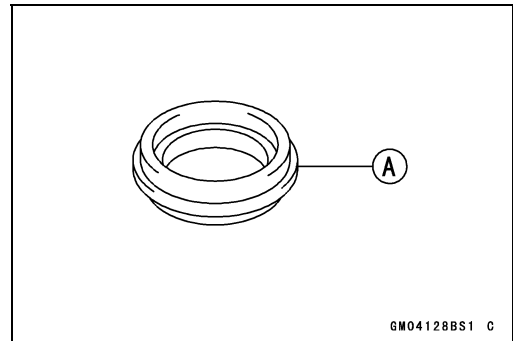



## Rear Shock Absorber

### Spring Preload Adjustment

- Using the steering stem nut wrench [A], turn the adjuster [B] to adjust the spring preload.

**Special Tool - Steering Stem Nut Wrench: 57001-1100**

#### Spring Preload Setting

**Standard Position: 2nd position**

**Adjustable Range: 1st ~ 4th position**

- ★ If the compression of the spring is not suited to the operating conditions, adjust it to an appropriate position by referring to the table below.

#### Spring Preload Adjustment

Adjuster Position	Shock Absorber Hardness	Load	Road Conditions	Driving Speed
1st	Soft	Light	Good	Low
↑	↑	↑	↑	↑
↓	↓	↓	↓	↓
4th	Hard	Heavy	Bad	High

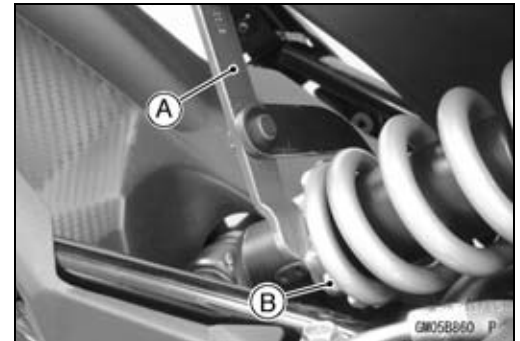

### Rear Shock Absorber Removal

- Raise the rear wheel off the ground with the jack.

**Special Tools - Jack: 57001-1238**

**Jack Attachment: 57001-1608**

- Remove:
  - Right Side/Frame Cover (see Side/Frame Cover Removal in the Frame chapter)
  - Rear Shock Absorber Bolts [A]
  - Rear Shock Absorber [B]

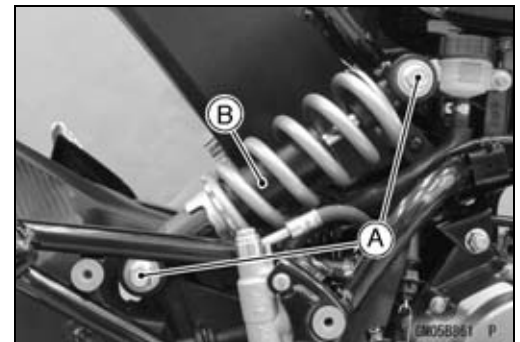

### Rear Shock Absorber Installation

- Install the rear shock absorber.
- The spring seat groove [A] faces downward.
- Tighten:
  - Torque - Rear Shock Absorber Bolts [B]: 59 N·m (6.0 kgf·m, 44 ft·lb)**
- Install the removed parts (see appropriate chapters).

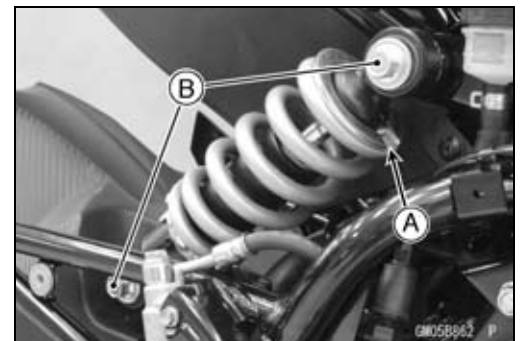

### Rear Shock Absorber Inspection

- Remove the rear shock absorber (see Rear Shock Absorber Removal).
- Visually inspect the following items.
  - Oil Leakage
  - Crack or Dent
- ★ If there is any damage to the rear shock absorber, replace it.
- Visually inspect the rubber bushings [A] for damage or deterioration.
- ★ If it show any signs of damage, replace it.

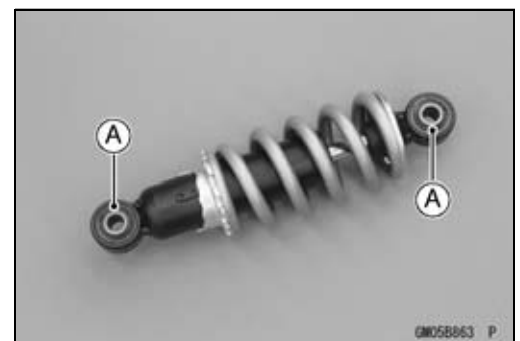

## 12-14 SUSPENSION

### Swingarm

#### **Swingarm Removal**

- Raise the rear wheel off the ground with the jack.  
**Special Tools - Jack: 57001-1238**  
**Jack Attachment: 57001-1608**
  - Remove:
    - Side/Frame Covers (see Side/Frame Cover Removal in the Frame chapter)
    - Mud Guard (see Mud Guard Removal in the Frame chapter)
    - Rear Wheel (see Rear Wheel Removal in the Wheels/Tires chapter)
  - Loosen the lower rear shock absorber bolt [A] and the swingarm pivot shaft nut [B].
  - Clear the brake hose from the clamps [C].
  - Remove:
    - Lower Rear Shock Absorber Bolt
    - Swingarm Pivot Shaft Nut
    - Swingarm Pivot Shaft [D]
  - Pull the swingarm [E] backward to remove it.
- 
- Pull the chain guide [A] off from the pin [B] on the swingarm to remove it.

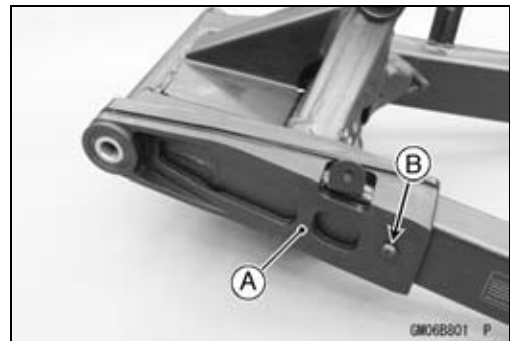
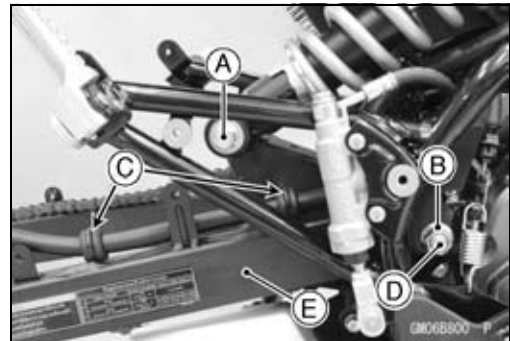

#### **Swingarm Installation**

- Installation is the reverse of removal.
- Tighten:
  - Torque - Lower Rear Shock Absorber Bolt [A]: 59 N·m (6.0 kgf·m, 44 ft·lb)
  - Swingarm Pivot Shaft Nut [B]: 88 N·m (9.0 kgf·m, 65 ft·lb)
- Install the removed parts (see appropriate chapters).

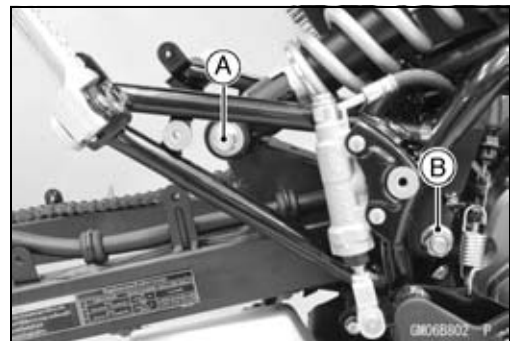

## Swingarm

### Swingarm Sleeve Inspection

- Remove:
  - Swingarm (see Swingarm Removal)
  - Sleeve [A]
  - O-rings (Both Sides) [B]
- Visually inspect the sleeve for abrasion, discoloration, or other damage.
- ★ If the sleeve shows any signs of abnormal wear, discoloration, or damage, replace it.

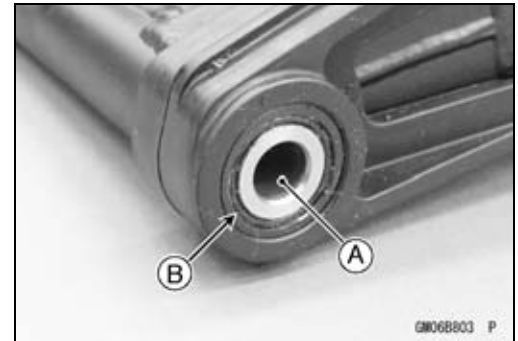

### Swingarm Bushing Removal

- Remove:
  - Swingarm (see Swingarm Removal)
  - O-rings [A]
  - Sleeve [B]

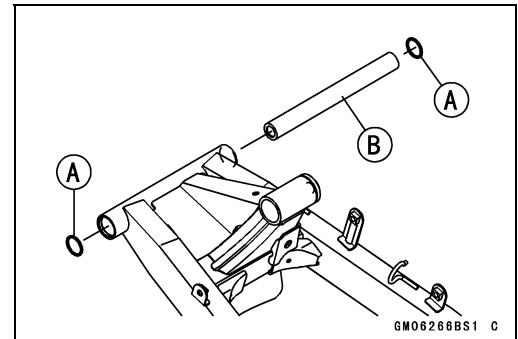

- Remove the swingarm bushings [A].
- Special Tool - Oil Seal & Bearing Remover [B]: 57001-1058**

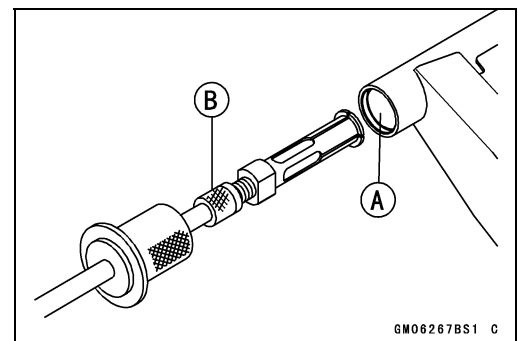

### Swingarm Bushing Installation

- Replace the swingarm bushing with a new one.
- Assemble the following special tools.
  - Bearing Driver Holder [A] (included in the bearing driver set)
  - Bearing Driver [B]
  - Spacer [C]
  - 5 mm (0.20 in.) [D]
  - 6 mm (0.24 in.) [E]

- Special Tools - Bearing Driver Set: 57001-1129**
  - Needle Bearing Driver,  $\phi 17/\phi 18$ : 57001-1609**
  - Spacer: 57001-1790**

- Press the swingarm bushing into the swingarm until the spacer contacts the end surface of the swingarm.

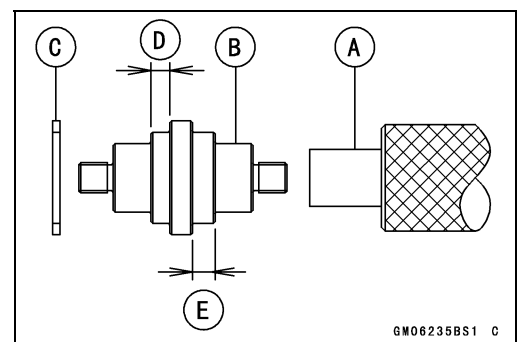

## 12-16 SUSPENSION

### Swingarm

○ If the special tools can not be prepared, press the swingarm bushing [A] as shown.  
3 mm (0.12 in.) [B]

- Replace the O-rings with new ones.
- Apply grease to the O-rings, and install it.

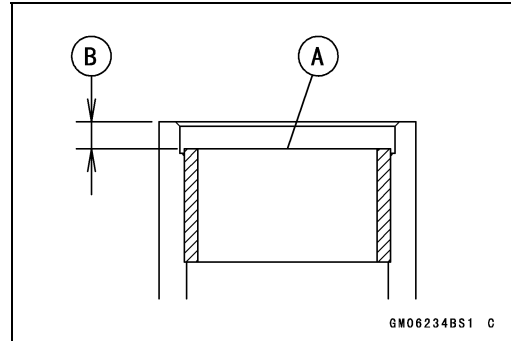

### **Swingarm Bushing Inspection**

- Visually inspect the bushings [A].
- ★ If they are deteriorated or damaged, replace them.



---

# Steering

## Table of Contents

Exploded View .....	13-2
Special Tools .....	13-4
Steering .....	13-5
Steering Inspection .....	13-5
Steering Adjustment.....	13-5
Steering Stem.....	13-6
Stem, Stem Bearing Removal.....	13-6
Stem, Stem Bearing Installation.....	13-7
Steering Stem Bearing Lubrication .....	13-8
Steering Stem Warp Inspection .....	13-9
Handlebars .....	13-10
Handlebar Removal .....	13-10
Handlebar Installation .....	13-11

# 13-2 STEERING

## Exploded View

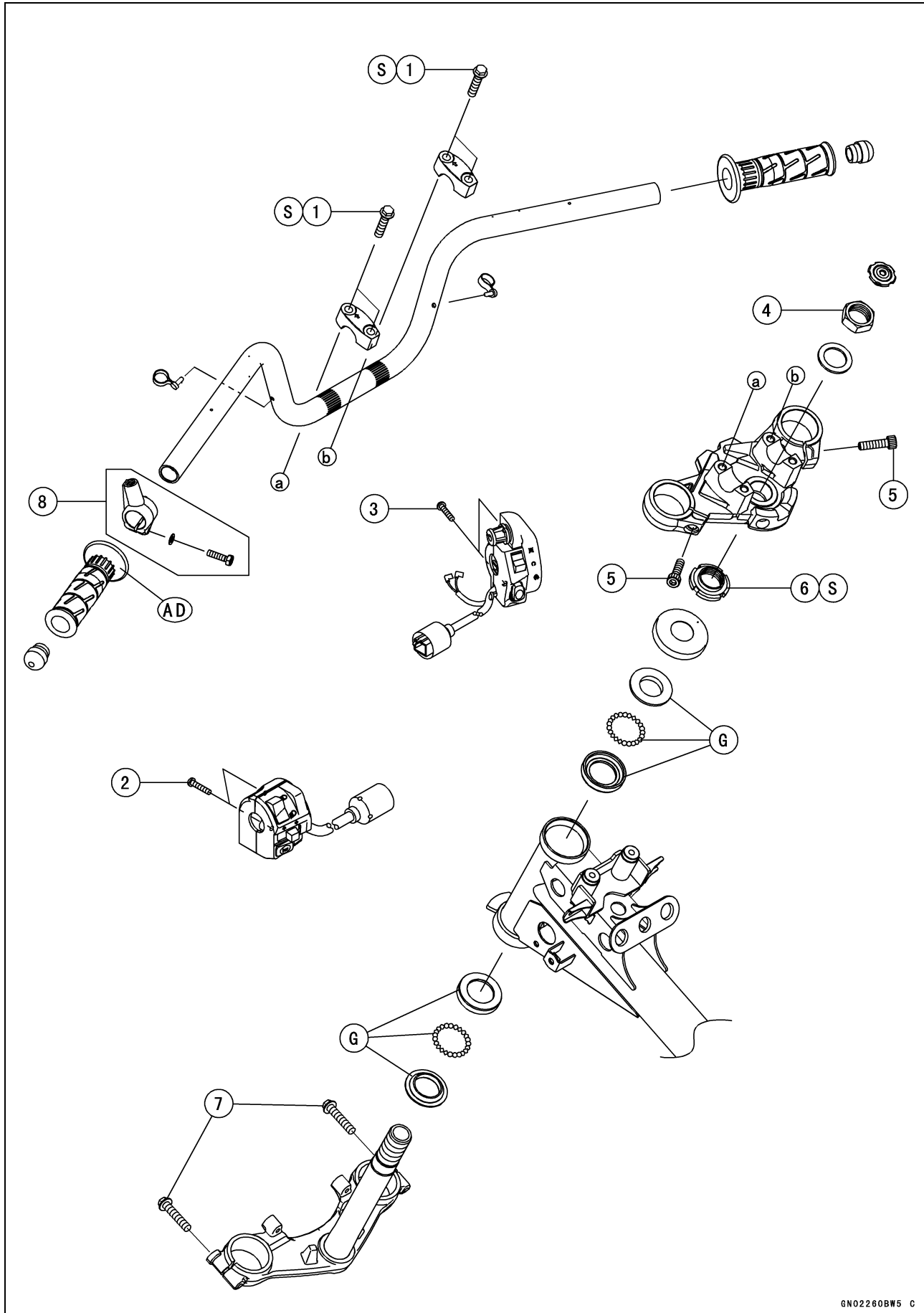

## Exploded View

No.	Fastener	Torque			Remarks
		N·m	kgf·m	ft·lb	
1	Handlebar Clamp Bolts	25	2.5	18	S
2	Left Switch Housing Screws	3.5	0.36	31 in·lb	
3	Right Switch Housing Screws	3.5	0.36	31 in·lb	
4	Steering Stem Head Nut	44	4.5	32	
5	Front Fork Clamp Bolts (Upper)	20	2.0	15	
6	Steering Stem Nut	7.4	0.75	65 in·lb	S
7	Front Fork Clamp Bolts (Lower)	20	2.0	15	

8. BR125G

AD: Apply adhesive.

G: Apply grease.

S: Follow the specified tightening sequence.

# 13-4 STEERING

## Special Tools

**Steering Stem Bearing Driver:**  
57001-137

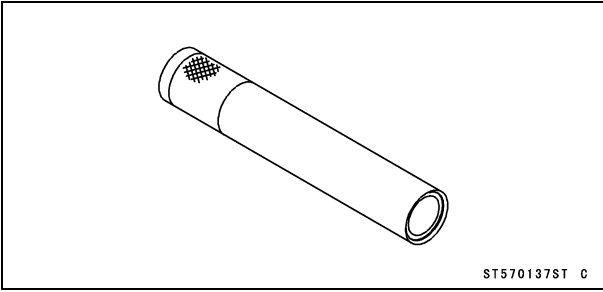

**Head Pipe Outer Race Press Shaft:**  
57001-1075

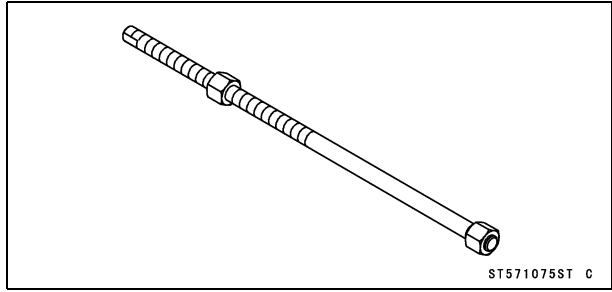

**Steering Stem Bearing Driver Adapter,  $\phi 32$ :**  
57001-292

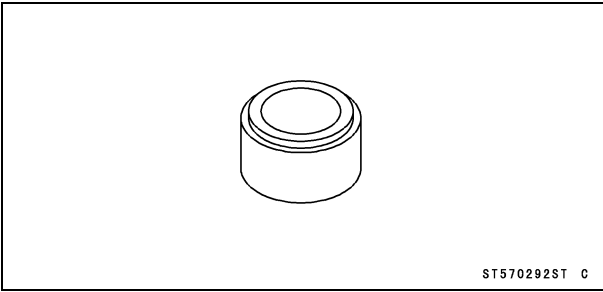

**Head Pipe Outer Race Driver,  $\phi 51.5$ :**  
57001-1076

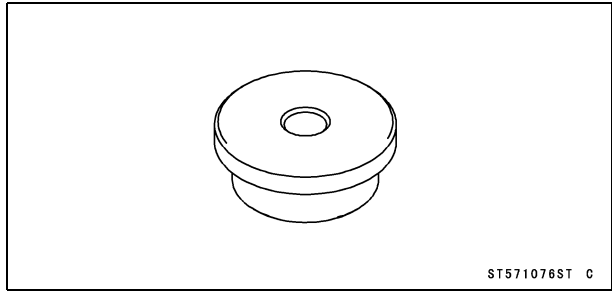

**Oil Seal & Bearing Remover:**  
57001-1058

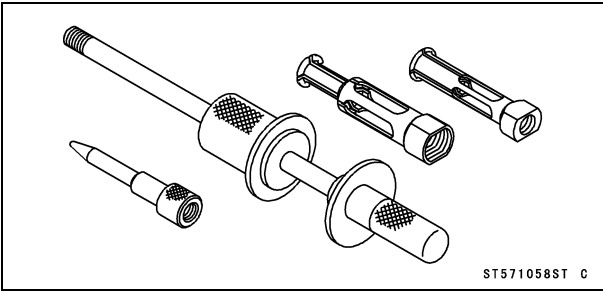

**Steering Stem Nut Wrench:**  
57001-1100

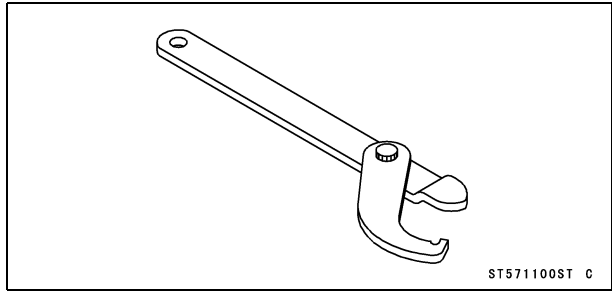



## Steering

---

### ***Steering Inspection***

- Refer to the Steering Play Inspection in the Periodic Maintenance chapter.

### ***Steering Adjustment***

- Refer to the Steering Play Adjustment in the Periodic Maintenance chapter.

## 13-6 STEERING

### Steering Stem

#### Stem, Stem Bearing Removal

- Remove:
  - Handlebars (see Handlebar Removal)
  - Steering Stem Head Nut Plug [A]
- Loosen the steering stem head nut [B].
- Remove:
  - Upper Fairing Bracket(s) (see Upper Fairing Bracket Removal in the Frame chapter)
  - Front Forks (see Front Fork Removal in the Suspension chapter)
- Remove:
  - Steering Stem Head Nut [A]
  - Washer [B]
  - Steering Stem Head [C]

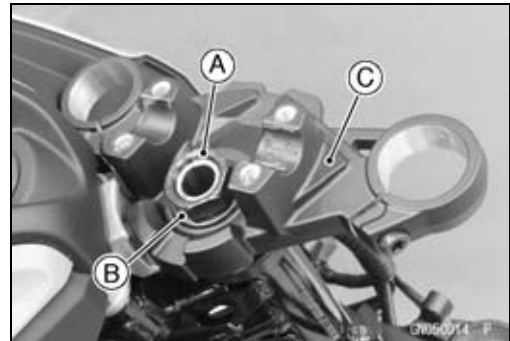
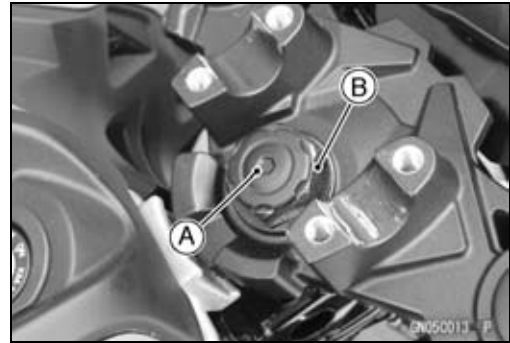

- Pushing up the stem base, and remove the steering stem nut [A].

**Special Tool - Steering Stem Nut Wrench [B]: 57001-1100**

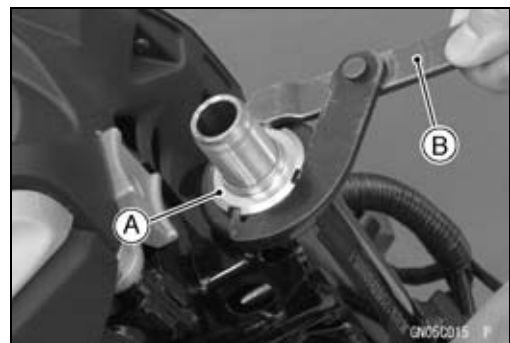

- Remove:
  - Steering Stem Cap [A]
  - Upper Inner Race [B]
  - Upper Steel Balls [C]
- There are 23 steel balls installed in the upper outer race.
- Remove the steering stem.
- Remove the remaining ball bearings from the lower outer race.
- There are 23 steel balls installed in the lower outer race.

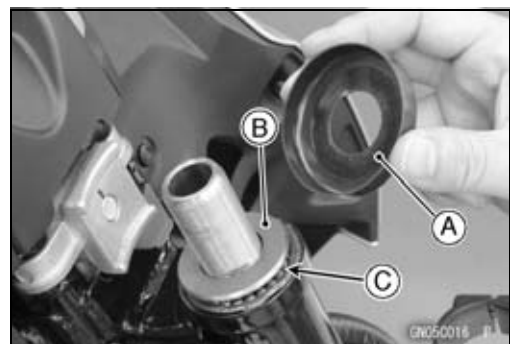

- Remove the upper and lower outer races using the remover [A].

**Special Tool - Oil Seal & Bearing Remover: 57001-1058**

#### NOTE

- If either steering stem bearing is damaged, it is recommended that both the upper and lower bearings (including outer races) should be replaced with new ones.

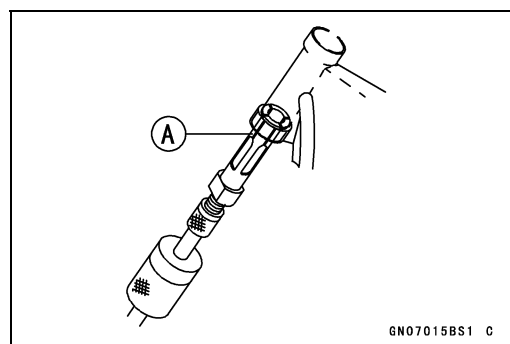

GN07015BS1 C

## Steering Stem

- Remove the lower inner race [A] on the steering stem with a suitable commercially available chisel [B].

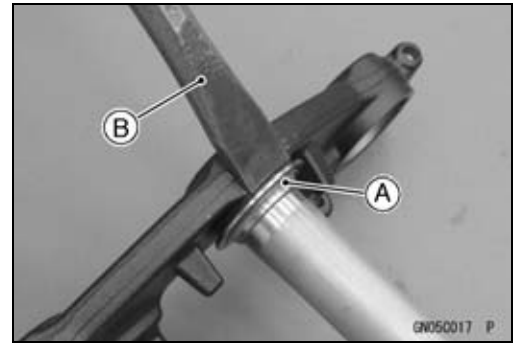

### Stem, Stem Bearing Installation

- Replace the outer races with new ones.
- Drive them into the head pipe at the same time.

Special Tools - Head Pipe Outer Race Press Shaft [A]:  
57001-1075

Head Pipe Outer Race Driver,  $\phi 51.5$  [B]:  
57001-1076

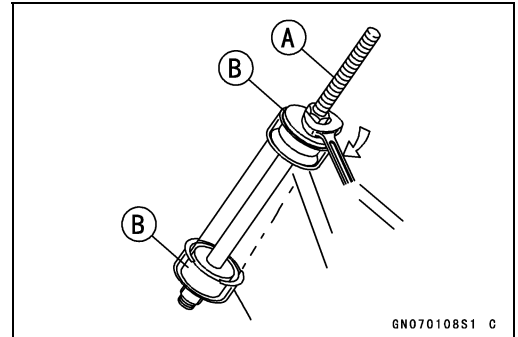

- Using the stem bearing driver [A], drive the lower inner race [B] onto the steering stem.

Special Tools - Steering Stem Bearing Driver: 57001-137  
Steering Stem Bearing Driver Adapter,  $\phi 32$  [C]: 57001-292

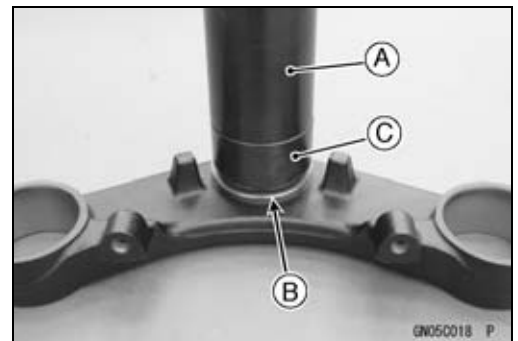

- Using high flash-point solvent, clean the stem bearing races and balls. Apply grease to the upper and lower outer races in the head pipe so that the steel balls [A] will stick in place during stem insertion.
- Install the upper steel balls (23) and lower steel balls (23).
- Install the upper inner race.

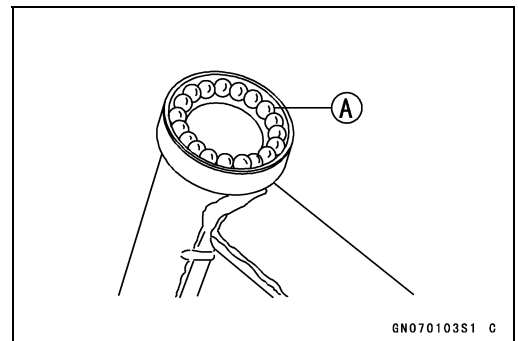

- Install the steering stem [A] carefully through the head pipe so that the steel balls on the head pipe does not fall.
- Apply grease to the upper ball bearing inner race and install it.
- Install the stem cap [B] and steering stem nut [C], and tighten it by hand.

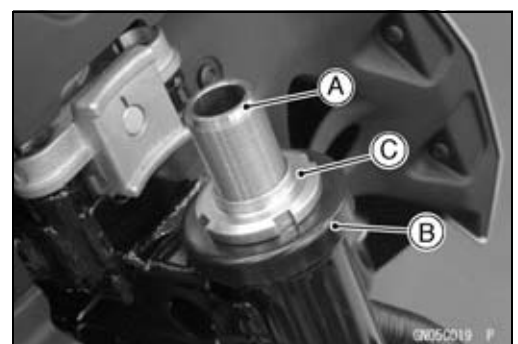

## 13-8 STEERING

### Steering Stem

- Settle the bearings in place as follows.
- Tighten the steering stem nut with **39 N·m (4.0 kgf·m, 29 ft·lb)** of torque first, and loosen it a fraction of a turn until it turns lightly. Afterward tighten it again with specified torque using the steering stem nut wrench [A].
- Check that there is no play and the steering stem turns smoothly without rattles. If not, the steering stem bearings may be damaged.

**Special Tool - Steering Stem Nut Wrench: 57001-1100**

**Torque - Steering Stem Nut: 7.4 N·m (0.75 kgf·m, 65 in·lb)**

- Install the stem head [A].
- Install the washer [B], and tighten the stem head nut [C] temporarily.
- Temporarily install the front forks [D] (see Front Fork Installation in the Suspension chapter).

#### NOTE

- Tighten the front fork clamp bolts (lower) loosely. Do not tighten the front fork clamp bolts (upper) at this time.

- Tighten the stem head nut [A].  
**Torque - Steering Stem Head Nut: 44 N·m (4.5 kgf·m, 32 ft·lb)**
- Tighten:  
**Torque - Front Fork Clamp Bolts (Upper) [B]: 20 N·m (2.0 kgf·m, 15 ft·lb)**  
**Front Fork Clamp Bolts (Lower) [C]: 20 N·m (2.0 kgf·m, 15 ft·lb)**

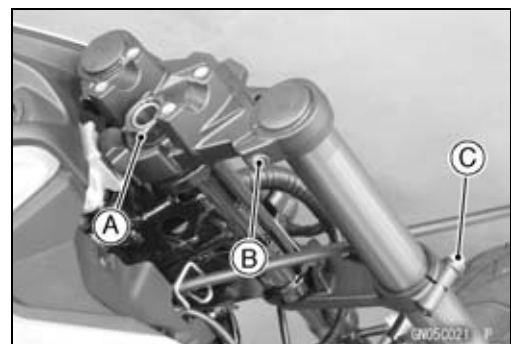
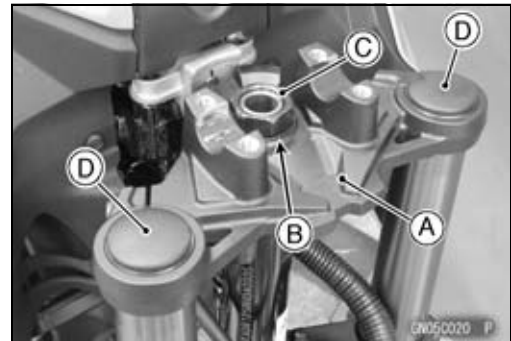
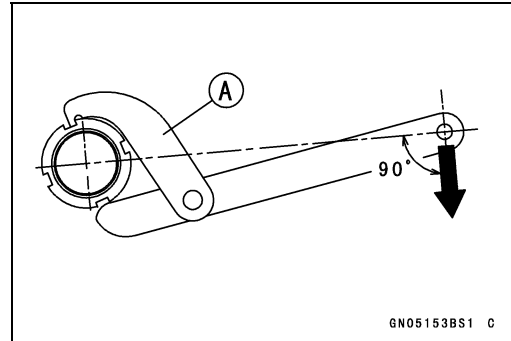

#### **⚠ WARNING**

**If the handlebars do not turn to the steering stop, they may cause an accident resulting in injury or death. Be sure the cables, harnesses and hoses are routed properly and do not interfere with handlebar movement (see Cable, Wire, and Hose Routing section in the Appendix chapter).**

- Run the leads, wire harness and hoses are routed correctly (see Cable, Wire, and Hose Routing section in the Appendix chapter).
- Install the removed parts (see appropriate chapters).

#### **Steering Stem Bearing Lubrication**

- Refer to the Steering Stem Bearing Lubrication in the Periodic Maintenance chapter.

---

## Steering Stem

---

### ***Steering Stem Warp Inspection***

- Whenever the steering stem is removed, or if the steering can not be adjusted for smooth action, check the steering stem for straightness [A].
- ★ If the steering stem is bent, replace it with a new one.

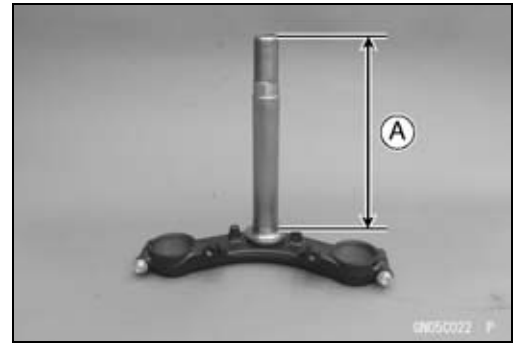

## 13-10 STEERING

### Handlebars

#### Handlebar Removal

- Open the clamps [A].

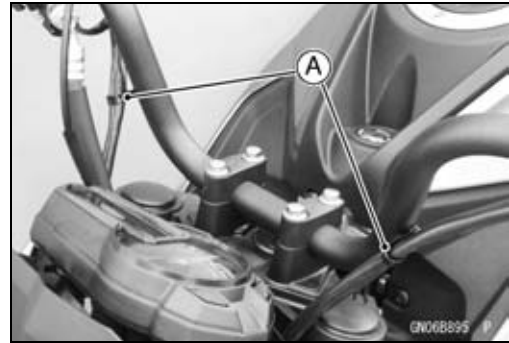

- Remove:
  - Rear View Mirrors (see Rear View Mirror Removal in the Frame chapter)
  - Screws [A]
  - Left Switch Housing [B]
- Disconnect (BR125H/J):
  - Clutch Cable Upper End [C] (see Clutch Cable Removal in the Clutch chapter)
  - Starter Lockout Switch Lead Connector [D]

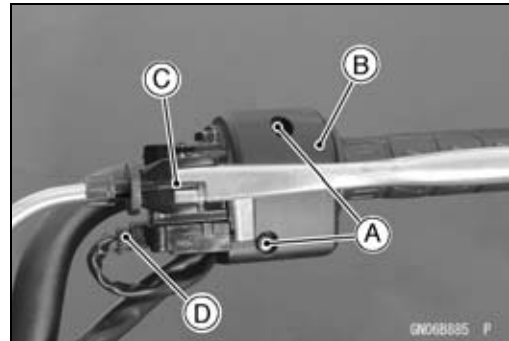

- Remove the left handlebar grip [A].
- Loosen the bolt [B] and remove the mirror holder (BR125G) or the clutch lever holder assembly [C] (BR125H/J).

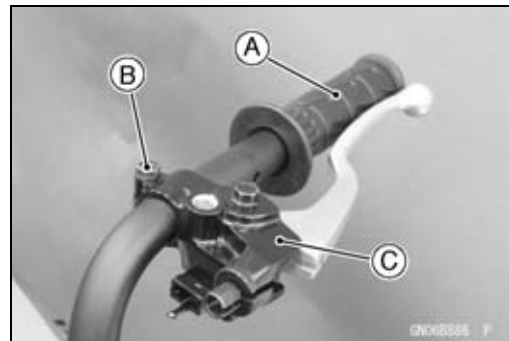

- Remove:
  - Front Master Cylinder [A] (see Front Master Cylinder Removal in the Brakes chapter)
  - Screws [B]
  - Right Switch Housing [C]
  - Throttle Grip [D]

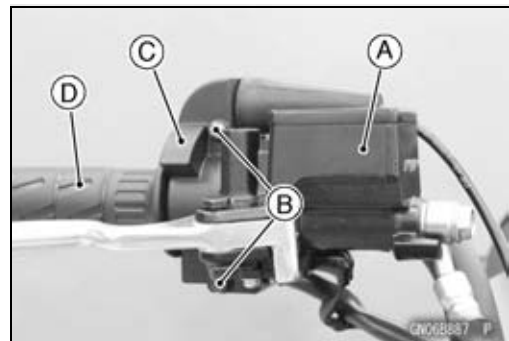

- Remove:
  - Handlebar Clamp Bolts [A]
  - Handlebar Clamps [B]
  - Handlebars [C]

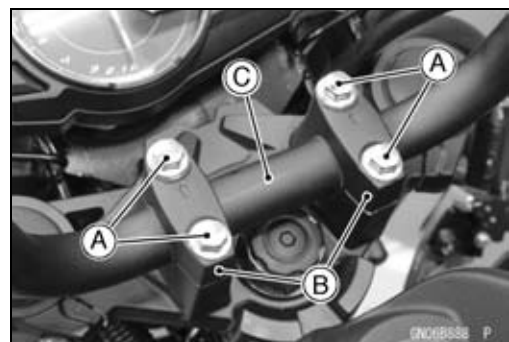

## Handlebars

### Handlebar Installation

- Before installing the handlebars, run the cables and leads in accordance with the Cable, Wire, and Hose Routing section in the Appendix chapter.
- Install the handlebars [A] and the clamps [B] so that the arrow marks [C] on the clamps point at the front.
- Align the punch mark [D] on the handlebars with the mating surface at rear of the handlebar clamp.

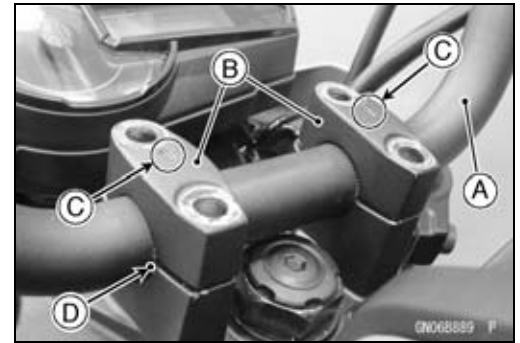

- Tighten the handlebar clamp bolts in the sequence [1 ~ 6].

**Torque - Handlebar Clamp Bolts: 25 N·m (2.5 kgf·m, 18 ft·lb)**

- If the handlebar clamps are correctly installed, there will be no gap at the front and a gap [A] at the rear after tightening.

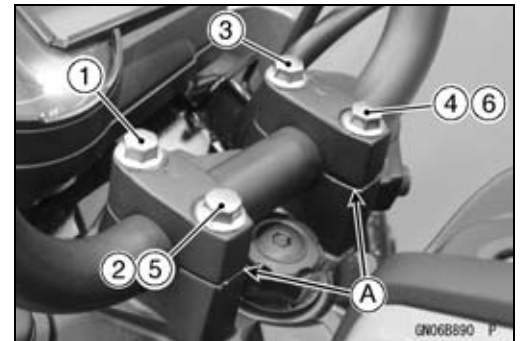

### BR125G

- Install the mirror holder, aligning its projection [A] with the punch mark [B] on the handlebars.
- Tighten the bolt securely.
- Apply adhesive to the inside of the left handlebar grip and install it to the handlebars.

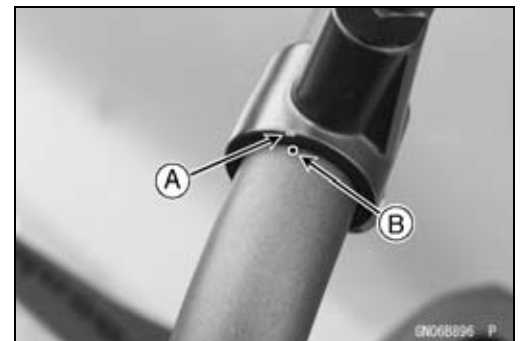

### BR125H/J

- Install the clutch lever holder assembly [A], aligning its mating surface with the punch mark [B] on the handlebars.
- Tighten the bolt [C] securely.
- Apply adhesive to the inside of the left handlebar grip and install it to the handlebars.
- Connect:
  - Starter Lockout Switch Connector
  - Clutch Cable Upper End

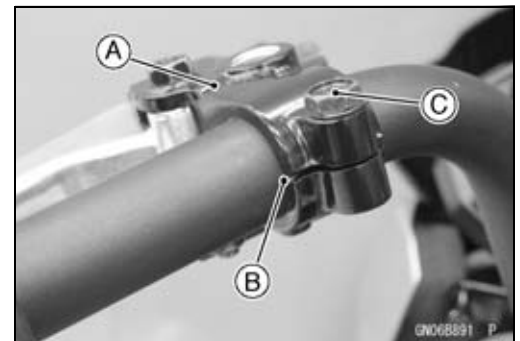

- Install the left switch housing to the handlebars so that the projection [A] on the housing case fits into the hole [B] on the handlebars.

- Tighten:

**Torque - Left Switch Housing Screws: 3.5 N·m (0.36 kgf·m, 31 in·lb)**

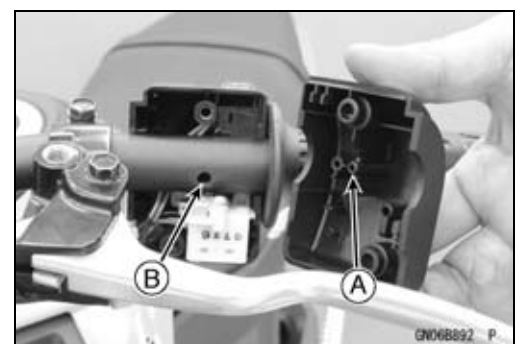

## 13-12 STEERING

### Handlebars

- Screw the throttle cable upper adjuster [A] into the right switch housing all the way.
  - Apply grease to the tips [B] of the cable and connect it to the throttle grip [C].
- 
- Install the right switch housing to the handlebars so that the projection [A] on the housing case fits into the hole [B] on the handlebars.
  - Tighten:  
**Torque - Right Switch Housing Screws: 3.5 N·m (0.36 kgf·m, 31 in·lb)**
  - Install:  
Front Master Cylinder (see Front Master Cylinder Installation in the Brakes chapter)  
Rear View Mirrors (see Rear View Mirror Installation in the Frame chapter)
  - Run the cables and leads correctly in accordance with the Cable, Wire, and Hose Routing section in the Appendix chapter.
  - Inspect and adjust the throttle grip free play if necessary (see Throttle Control System Inspection in the Periodic Maintenance chapter).
  - For BR125H/J, inspect and adjust the clutch cable (see Clutch Operation Inspection in the Periodic Maintenance chapter).

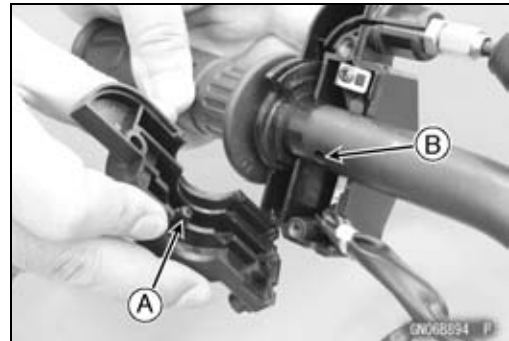
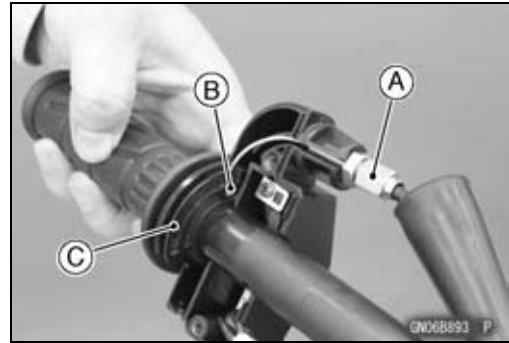



# Frame

## Table of Contents

Exploded View.....	14-2	Seat Cover Installation.....	14-17
Seat.....	14-8	Fenders.....	14-18
Seat Removal.....	14-8	Front Fender Removal.....	14-18
Seat Installation.....	14-8	Front Fender Installation.....	14-18
Fairings.....	14-9	Flap Removal.....	14-18
Lower Fairing Removal.....	14-9	Flap Installation.....	14-18
Lower Fairing Installation.....	14-9	Rear Fender Removal.....	14-19
Middle Fairing Removal.....	14-10	Rear Fender Installation.....	14-19
Middle Fairing Installation.....	14-10	Frame.....	14-20
Meter Cover Removal.....	14-11	Frame Inspection.....	14-20
Meter Cover Installation.....	14-11	Guard.....	14-21
Upper Faring Removal.....	14-11	Mud Guard Removal.....	14-21
Upper Faring Installation.....	14-11	Mud Guard Installation.....	14-21
Upper Faring Bracket Removal....	14-12	Footpegs.....	14-22
Upper Faring Bracket Installation.	14-12	Footpeg Removal.....	14-22
Covers.....	14-14	Footpeg Installation.....	14-22
Side/Frame Cover Removal.....	14-14	Front Footpeg Bracket Removal..	14-22
Side/Frame Cover Installation.....	14-14	Front Footpeg Bracket	
Side/Frame Cover Disassembly ..	14-15	Installation.....	14-22
Side/Frame Cover Assembly.....	14-15	Side Stand.....	14-23
Fuel Tank Cover Removal.....	14-15	Side Stand Removal.....	14-23
Fuel Tank Cover Installation.....	14-16	Side Stand Installation.....	14-23
Inner Cover Removal.....	14-16	Rear View Mirrors.....	14-24
Inner Cover Installation.....	14-16	Rear View Mirror Removal.....	14-24
Seat Covers.....	14-17	Rear View Mirror Installation.....	14-24
Seat Cover Removal.....	14-17		

# 14-2 FRAME

## Exploded View

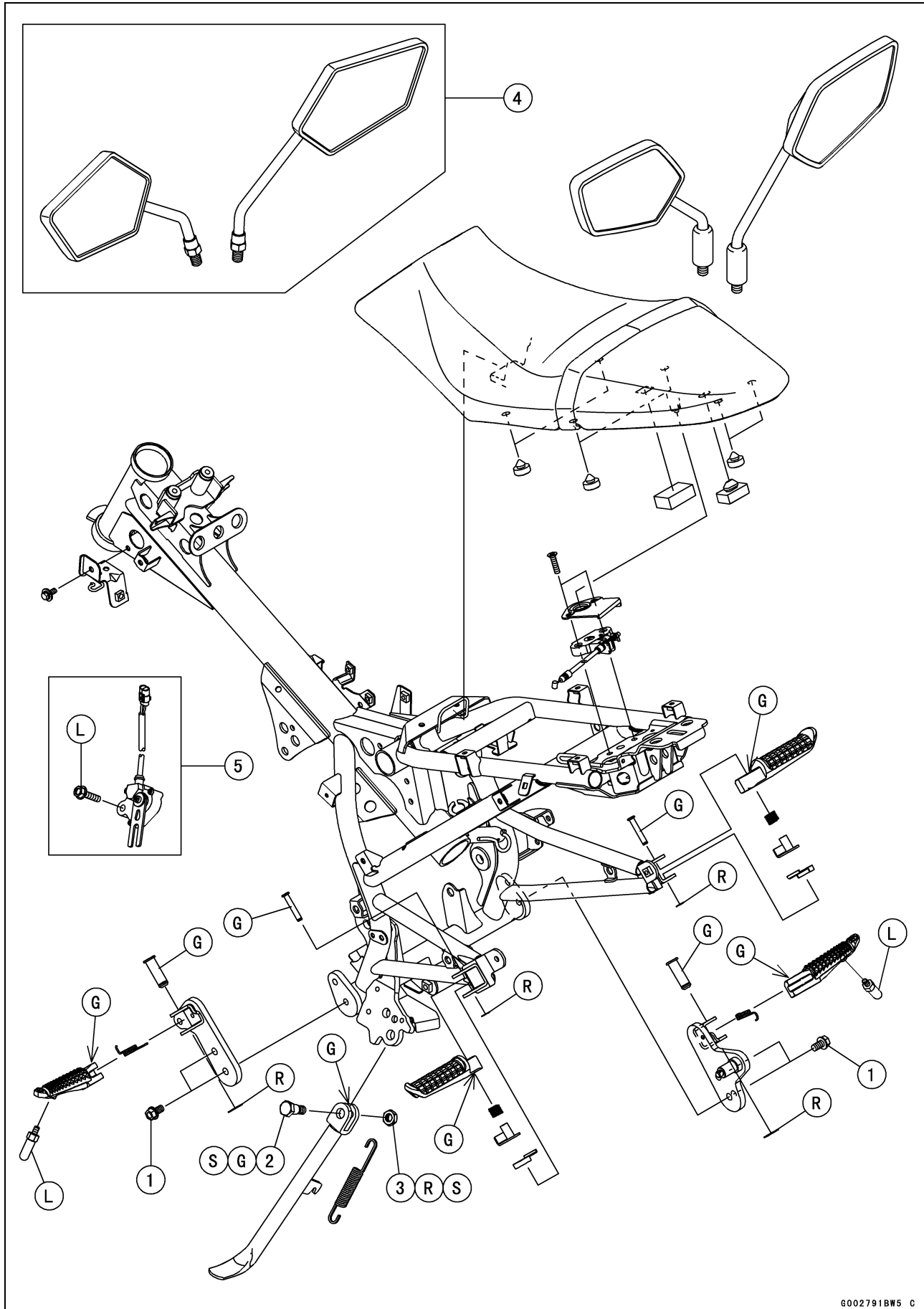

**Exploded View**

No.	Fastener	Torque			Remarks
		N·m	kgf·m	ft·lb	
1	Front Footpeg Bracket Bolts	25	2.5	18	
2	Side Stand Bolt	29	3.0	21	G, S
3	Side Stand Nut	44	4.5	32	R, S

4. PH and TH Models

5. BR125J

G: Apply grease.

L: Apply a non-permanent locking agent.

R: Replacement Parts

S: Follow the specified tightening sequence.

# 14-4 FRAME

## Exploded View

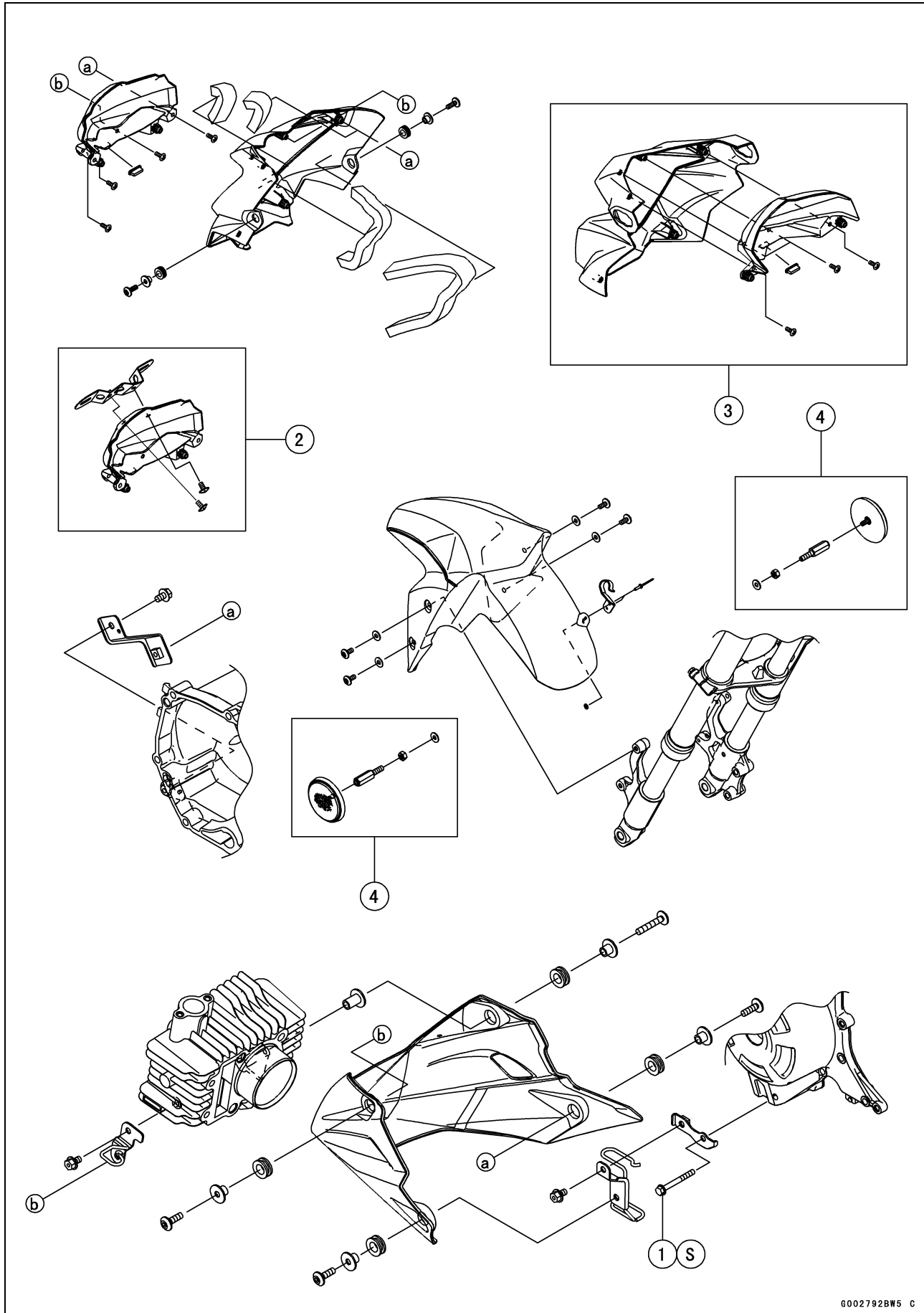

**Exploded View**

No.	Fastener	Torque			Remarks
		N·m	kgf·m	ft·lb	
1	Alternator Cover Bolts	8.8	0.90	78 in·lb	S

2. ID Model

3. BR125J

4. BR125H (MY Model) and BR125J

S: Follow the specified tightening sequence.

# 14-6 FRAME

## Exploded View

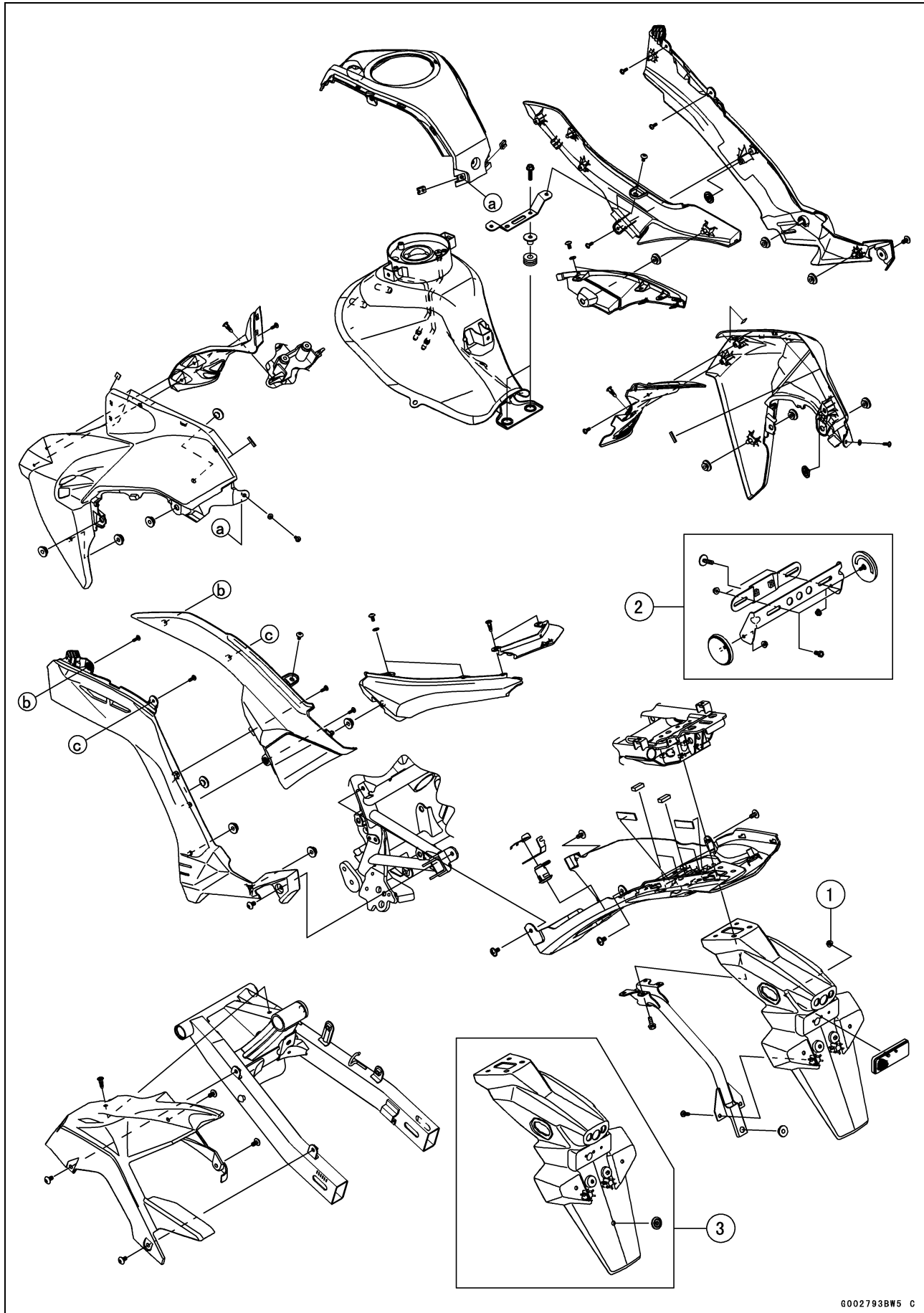

**Exploded View**

No.	Fastener	Torque			Remarks
		N·m	kgf·m	ft·lb	
1	Reflector Nut	3.4	0.35	30 in·lb	

2. BR125J (Other than AU Models)
3. BR125J (CA Model)

## 14-8 FRAME

### Seat

#### Seat Removal

- Insert the ignition key [A] into the seat lock and, turning the key clockwise, pulling up on the rear of the seat [B], and pulling the seat backward.

#### NOTE

- *The regulator/rectifier could become hot while the engine is running or shortly after it has been stopped. Do not touch the regulator/rectifier in such situations.*

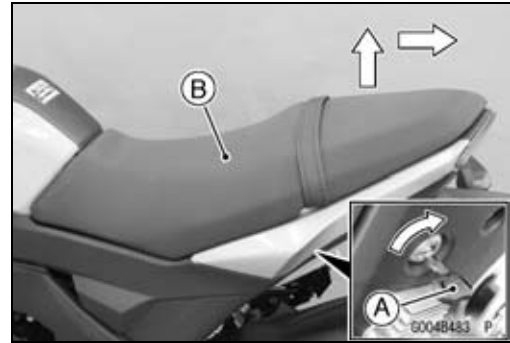

#### Seat Installation

- Insert the hook [A] on the front of the seat to the bracket [B].
- Insert the projection [C] on the rear of the seat into the hole [D] of the seat lock.
- Push down the rear part of the seat until the lock clicks.
- Pull up the front and rear end of the seat to make sure they are securely locked.

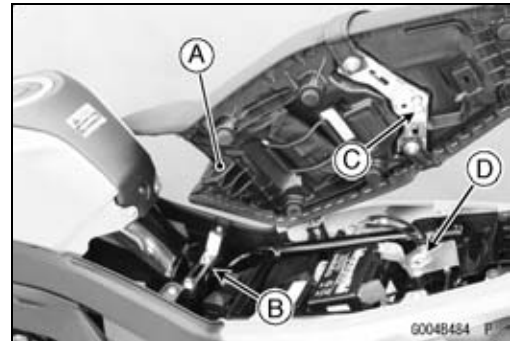



## Fairings

### Lower Fairing Removal

- Remove:
  - Bolts [A] (Both Sides)
  - Collar [B] (Right Side only)
  - Lower Fairing [C]

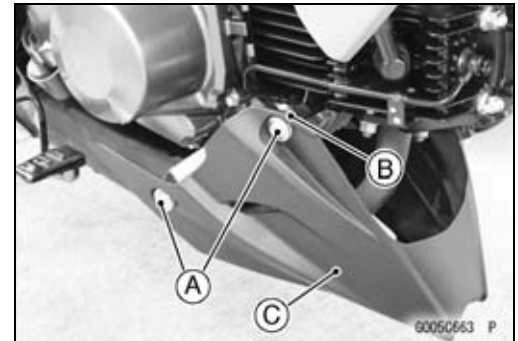

- Remove the following part if necessary.
  - Lower Faring Brackets Bolts [A]
  - Lower Faring Brackets [B]
  - Left Side [C]
  - Right Side [D]

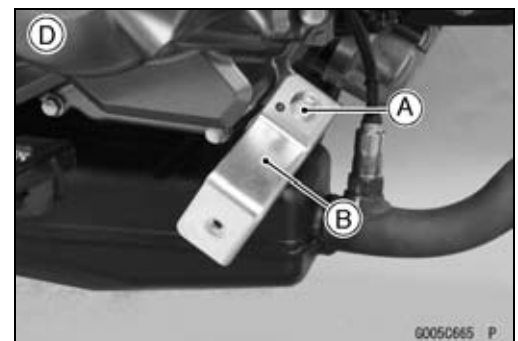

### Lower Fairing Installation

- Installation is the reverse of removal.
- Install the right side lower fairing bracket [A] if removed.
  - Fit the projection [B] into a hole [C] in the bracket.

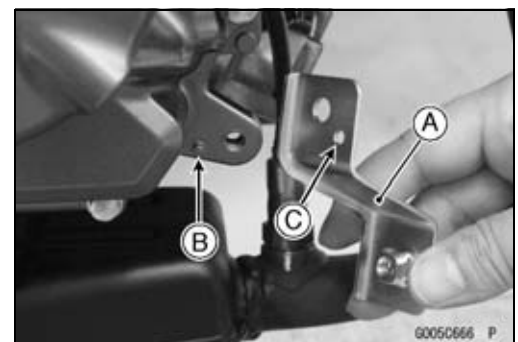

- Check that the collars [A] and dampers [B] are in place on the lower fairing.

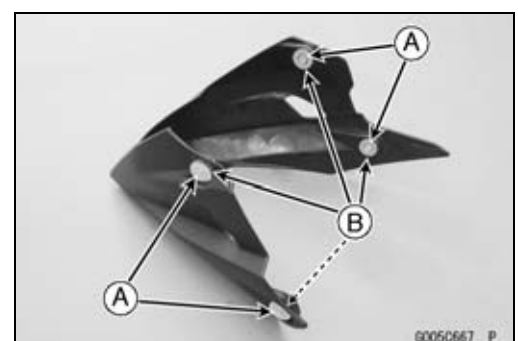

## 14-10 FRAME

### Fairings

#### **Middle Fairing Removal**

- Remove:
  - Side/Frame Cover (see Side/Frame Cover Removal)
  - Quick Rivet [A]



- Remove the screw [A] and washer [B].



- Pull the middle fairing outward to clear the projection [A].
- Remove the middle fairing [B] upward.

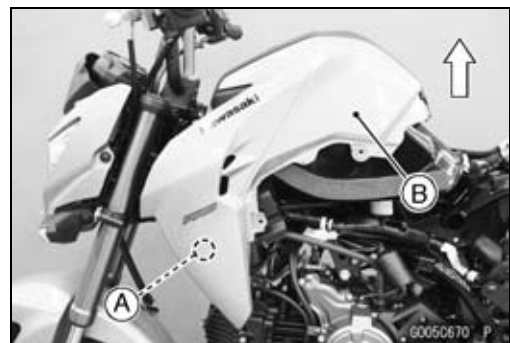

#### **Middle Fairing Installation**

- Installation is the reverse of removal.
- Check that the damper [A] is in place on the middle fairing.



- Check that the pads [A] are in place on the middle fairing.

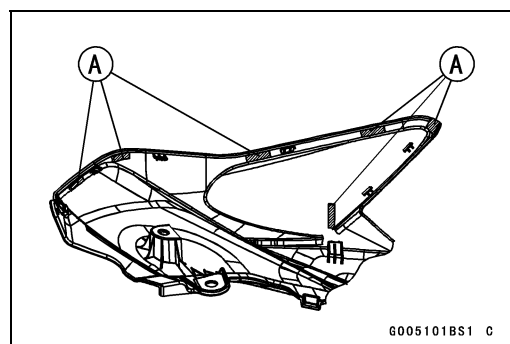

## Fairings

- Check that the grommet [A] is in place on the air cleaner housing.  
Outside [B]

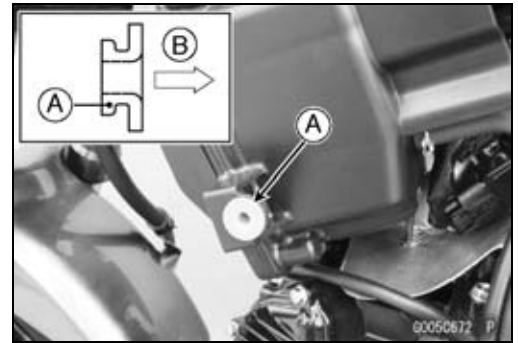

- Insert the tabs [A] of the middle fairing into the slots [B].
- Insert the projection [C] of the middle fairing into the grommet [D].

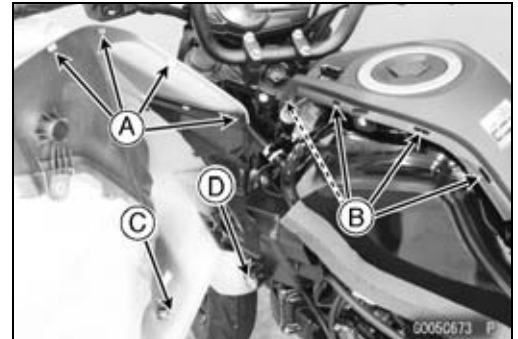

### **Meter Cover Removal**

- Refer to the Upper Fairing Removal.

### **Meter Cover Installation**

- Refer to the Upper Fairing Installation.

### **Upper Fairing Removal**

- Remove:  
Headlight Unit (see Headlight Unit Removal in the Electrical System chapter)
- Remove (BR125G/H):  
Screws [A]  
Meter Cover [B]  
Upper Fairing [C]

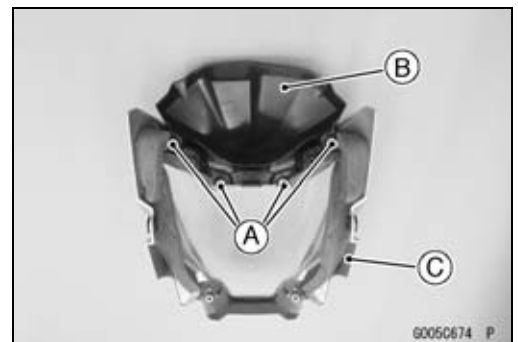

- Remove (BR125J):  
Screws [A]  
Meter Cover [B]  
Upper Fairing [C]

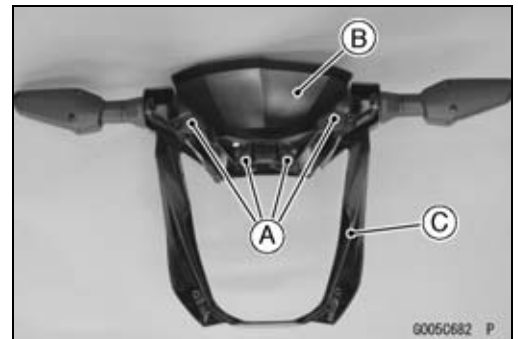

### **Upper Fairing Installation**

- Installation is the reverse of removal.

## 14-12 FRAME

### Fairings

#### **Upper Faring Bracket Removal**

- Disconnect the front brake hose upper end (see Front Master Cylinder Removal in the Brakes chapter).
- Remove:
  - Headlight Unit (see Headlight Unit Removal in the Electrical System chapter)
  - Meter Unit (see Meter Unit Removal in the Electrical System chapter)

#### **BR125G/H**

- Open the clamps [A] and band [B].
- Disconnect the front turn signal light lead connectors [C], and remove them from the upper fairing bracket.

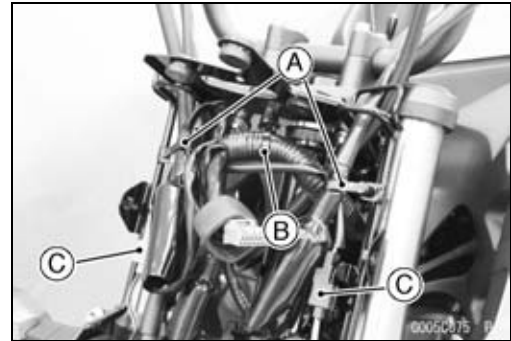

- Remove:
  - Bolts [A]
  - Upper Fairing Bracket [B]

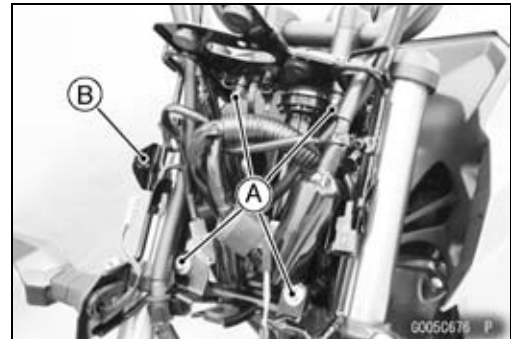

#### **BR125J**

- Open the band [A].
- Remove:
  - Bolts [B]
  - Upper Fairing Brackets [C]

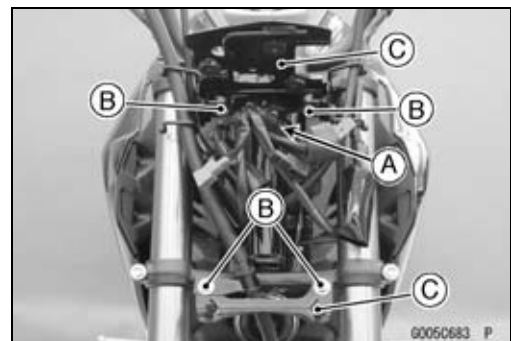

#### **Upper Faring Bracket Installation**

- Installation is the reverse of removal.

#### **BR125J**

- Install the upper fairing brackets [A].
- Tighten the bolts following the specified tightening sequence [1 ~ 4].

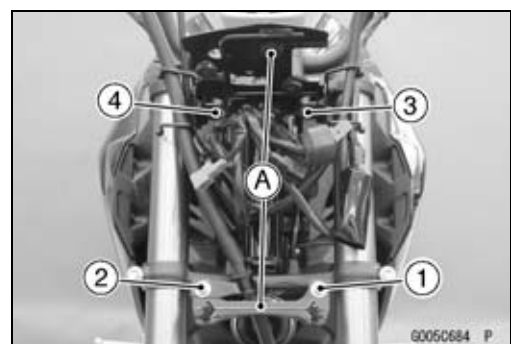

**Fairings**

---

- Run the leads, hoses and cables correctly (see Cable, Wire, and Hose Routing section in the Appendix chapter).
- Bleed the brake line (see Brake Line Bleeding in the Brakes chapter).
- Check the brake for good braking power, no brake drag, and no fluid leakage.

# 14-14 FRAME

## Covers

### Side/Frame Cover Removal

- Remove:
  - Seat (see Seat Removal)
  - Screw [A]
  - Bolt [B]
- Clear the hook [A] of the side/frame cover [B] outward.
- Pull the side/frame cover outward to clear the projections [C].

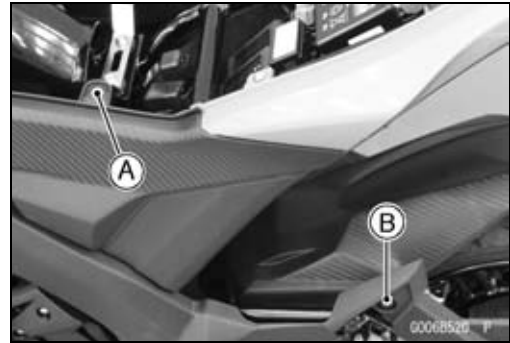

### Side/Frame Cover Installation

- Installation is the reverse of removal.
- Check that the damper [A] is in place on the side/frame cover.
- Check that the grommets [A] are in place on the frame, middle fairing and side seat cover.
  - Outside [B]
- Insert the tab [A] inside the middle fairing [B].
- Insert the projections [C] into the grommets [D].

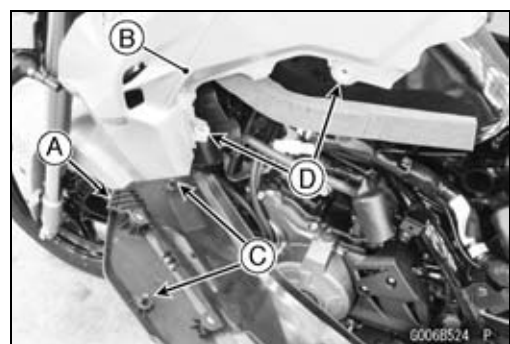
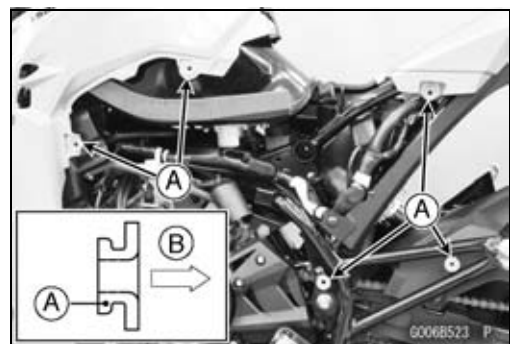
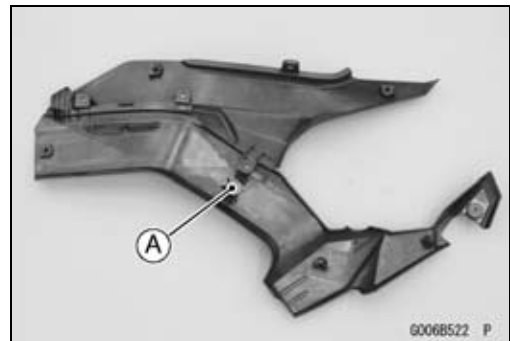

**Covers**

- Insert the projections [A] into the grommets [B].
- Insert the hook [C] into the slot [D] of the side seat cover.

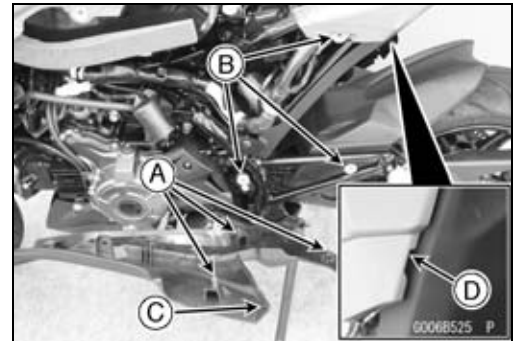

**Side/Frame Cover Disassembly**

- Remove:
  - Side/Frame Cover (see Side/Frame Cover Removal)
  - Screws [A]
  - Side Cover [B]
  - Frame Cover [C]
  - Left Side/Frame Cover [D]
  - Right Side/Frame Cover [E]

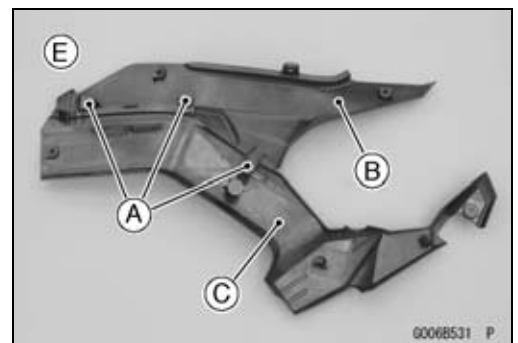
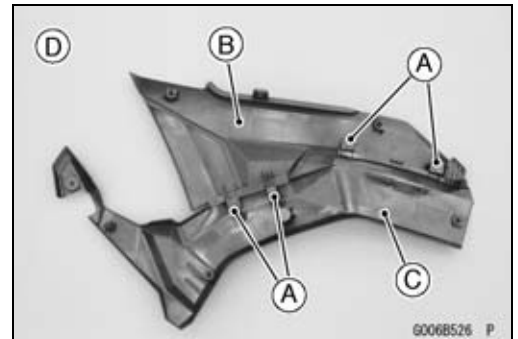

**Side/Frame Cover Assembly**

- Assembly is the reverse of disassembly.

**Fuel Tank Cover Removal**

- Remove:
  - Middle Fairings (see Middle Fairing Removal)
  - Bolt [A]
  - Bolt [B] (Both Sides)
- Remove the fuel tank cover [C] upward.

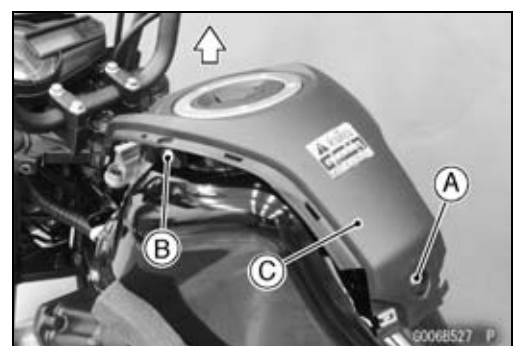

## 14-16 FRAME

### Covers

#### ***Fuel Tank Cover Installation***

- Installation is the reverse of removal.
- Check that the grommets [A] are in place on the fuel tank cover.

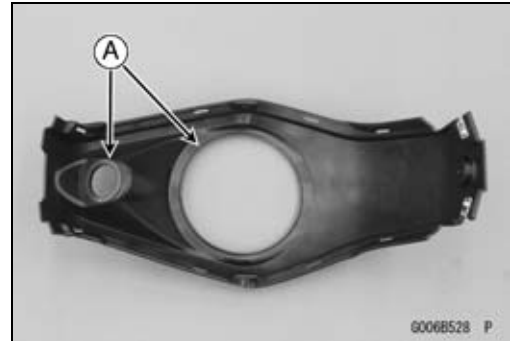

#### ***Inner Cover Removal***

- Remove:
  - Middle Fairing (see Middle Fairing Removal)
  - Screws [A]
  - Inner Cover [B]

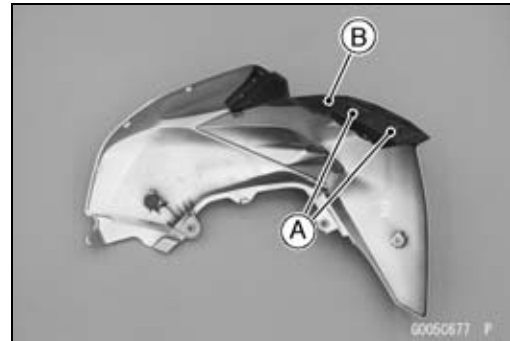

#### ***Inner Cover Installation***

- Installation is the reverse of removal.



## Seat Covers

### Seat Cover Removal

- Remove:
  - Seat (see Seat Removal)
  - Side/Frame Covers (see Side/Frame Cover Removal)
  - Quick Rivets [A]
- Remove the upper seat cover [B] to backward.

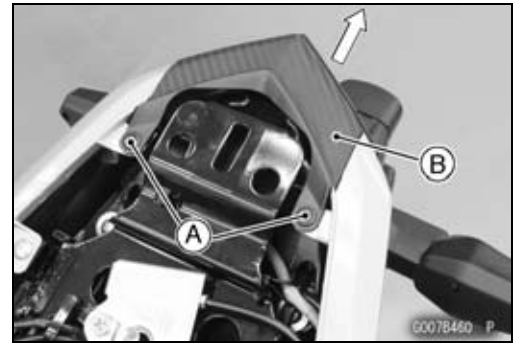

- Remove the screws [A].
- Remove the side seat covers [B] to backward.

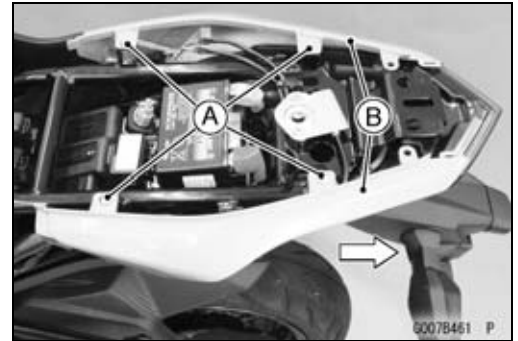

### Seat Cover Installation

- Installation is the reverse of removal.
- Insert the hooks [A] of the side seat cover into the slots [B] of the rear fender.

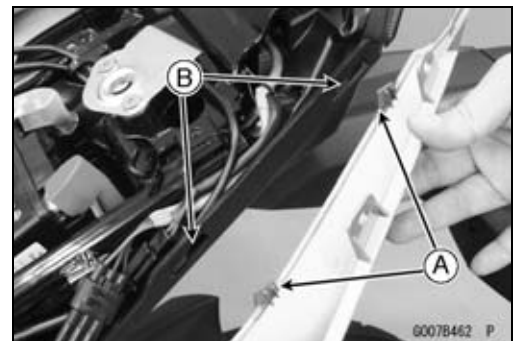

- Check that the grommet [A] is in place on the tail/brake light (LED).



- Insert the hooks [A] of the upper seat cover into the slots [B].
- Insert the tab [C] of the upper seat cover into the grommet [D].

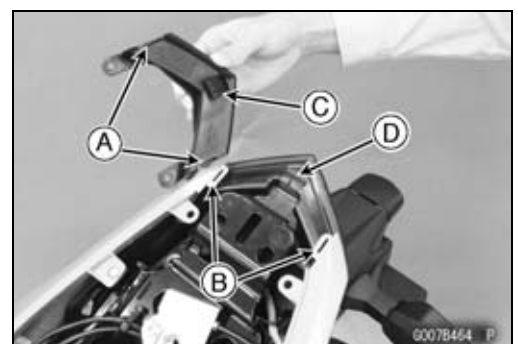

## 14-18 FRAME

### Fenders

#### **Front Fender Removal**

- Remove the bolts [A] (both sides).
- Clear the brake hose [B] from the clamp [C].
- Remove the front fender [D].



#### **Front Fender Installation**

- Installation is the reverse of removal.

#### **Flap Removal**

- Remove the side seat covers (see Seat Cover Removal).
- Remove the cover from the license plate light lead connector.
- Open the clamps [A].
- Disconnect:
  - Rear Turn Signal Light Lead Connectors [B]
  - Tail/Brake Light Lead Connector [C]
  - License Plate Light Lead Connector [D]

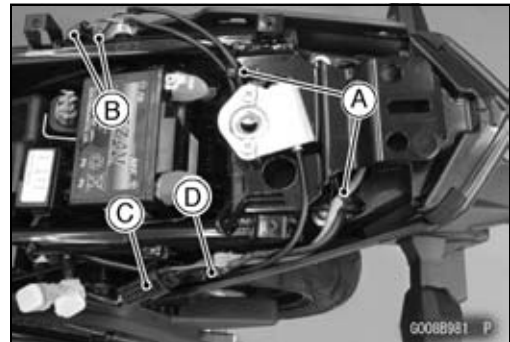

- Remove the cover [A].



- Remove:
  - Bolts [A]
  - Flap [B]

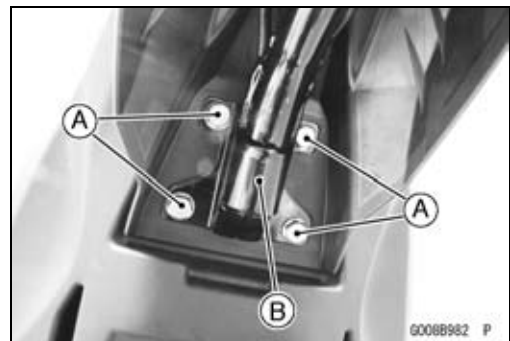

#### **Flap Installation**

- Installation is the reverse of removal.
- Run the leads correctly (see Cable, Wire, and Hose Routing section in the Appendix chapter).

## Fenders

### Rear Fender Removal

- Remove:
  - Battery (see Battery Removal in the Electrical System chapter)
  - Seat Covers (see Seat Cover Removal)
  - Flap (see Flap Removal)
  - ECU [A] (see ECU Removal in the Fuel System (DFI) chapter)
  - Seat Lock Bracket Screws [B]
  - Fuse Box [C]
- Disconnect:
  - Vehicle-down Sensor Connector [D]
- Remove:
  - ECU Bracket Bolt [A]
  - ECU Bracket
  - Screws [B] (Both Sides)
  - Rear Fender [C]

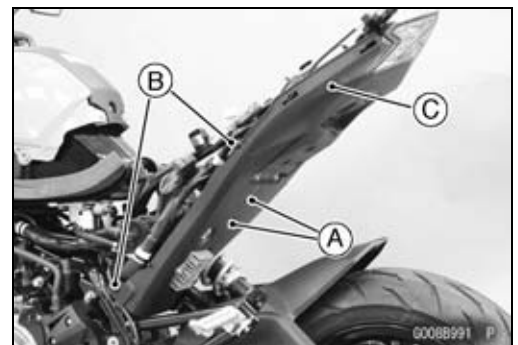
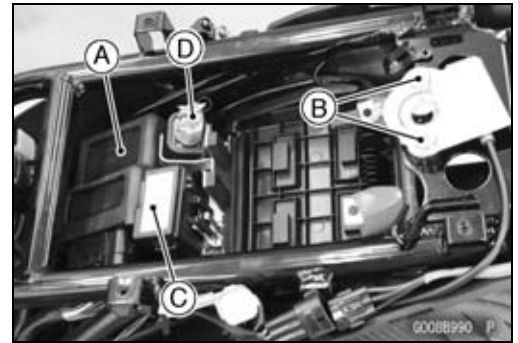

### Rear Fender Installation

- Installation is the reverse of removal.
- Check that the damper [A] is in place on the fuse box bracket.
  - 15 ~ 20 mm (0.59 ~ 0.79 in.) [B]
- Run the leads and cables correctly (see Cable, Wire, and Hose Routing section in the Appendix chapter).

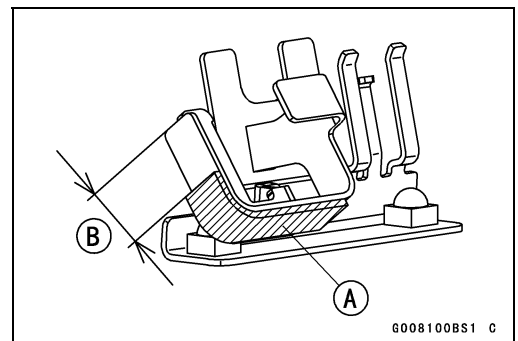

## 14-20 FRAME

---

### Frame

---

#### ***Frame Inspection***

- Visually inspect the frame for cracks, dents, bending, or warp.
- ★ If there is any damage to the frame, replace it.

<b> WARNING</b>
--

<b>A repaired frame may fail in use, possibly causing an accident resulting in injury or death. If the frame is bent, dented, cracked, or warped, replace it.</b>
---

---

**Guard**

---

***Mud Guard Removal***

- Remove the quick rivet [A].

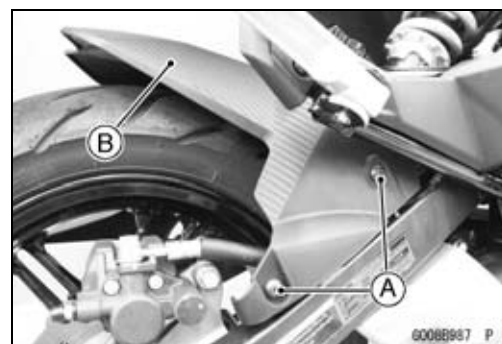

- Remove:
  - Mud Guard Mounting Bolts [A] (Both Sides)
  - Mud Guard [B]

***Mud Guard Installation***

- Installation is the reverse of removal.

## 14-22 FRAME

### Footpegs

#### **Footpeg Removal**

- Remove:
  - Circlips [A]
  - Pivot Pins [B]
  - Front Footpeg [C]
  - Rear Footpeg [D]
  - Spring [E]
  - Spring [F]
  - Step Collar [G]
  - Washer [H]
  - Bank Sensor [I] (if necessary)

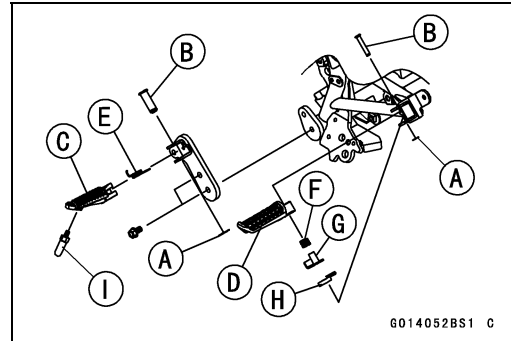

#### **Footpeg Installation**

- Installation is the reverse of removal.
- Replace the circlips with new ones.
- Apply a non-permanent locking agent to the threads of the bank sensor.
- Apply grease to the pivot pin and sliding area of the footpeg.
- Insert the pivot pin from the upper side.

#### **Front Footpeg Bracket Removal**

##### **Left Front Footpeg Bracket**

- Remove:
  - Shift Pedal (see Shift Pedal Removal in the Crankshaft/Transmission chapter)
  - Front Footpeg Bracket Bolts [A]
  - Front Footpeg Bracket [B]
- Remove the front footpeg [C] from the bracket if necessary (see Footpeg Removal).

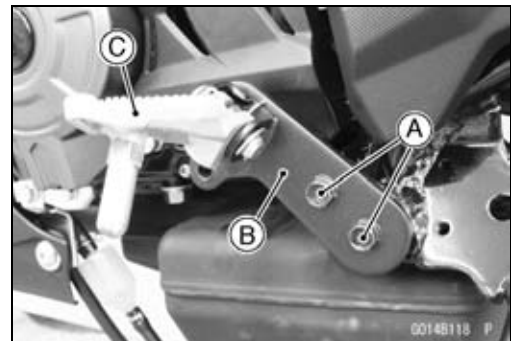

##### **Right Front Footpeg Bracket**

- Refer to the Brake Pedal Removal in the Brakes chapter.

#### **Front Footpeg Bracket Installation**

- Installation is the reverse of removal.
- Tighten:
  - Torque - Front Footpeg Bracket Bolts: 25 N·m (2.5 kgf·m, 18 ft·lb)

## Side Stand

### Side Stand Removal

- Raise the rear wheel off the ground with the stand.
- Remove (BR125J):  
Side Stand Switch Bolt [A]  
Side Stand Switch [B]

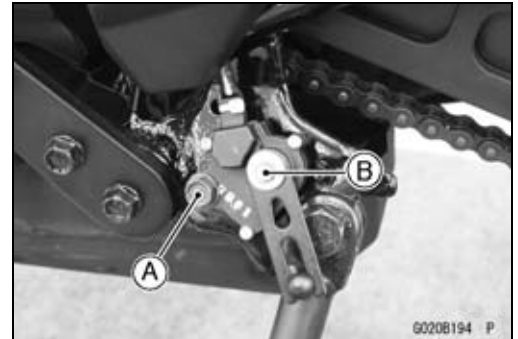

- Remove:  
Spring [A]  
Side Stand Nut [B]  
Side Stand Bolt [C]  
Side Stand [D]

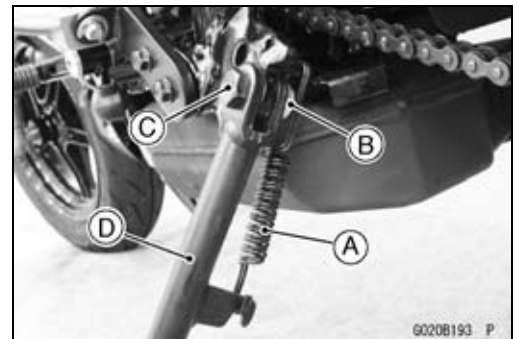

### Side Stand Installation

- Apply grease to the sliding area [A] of the side stand [B] and side stand bolt [C].
- Replace the side stand nut [D] with a new one.
- Tighten the side stand bolt first, and then the side stand nut.

**Torque - Side Stand Bolt: 29 N·m (3.0 kgf·m, 21 ft·lb)**

**Side Stand Nut: 44 N·m (4.5 kgf·m, 32 ft·lb)**

- Hook the spring [E] so that the long spring end faces upward.
- Install the spring hook direction as shown.

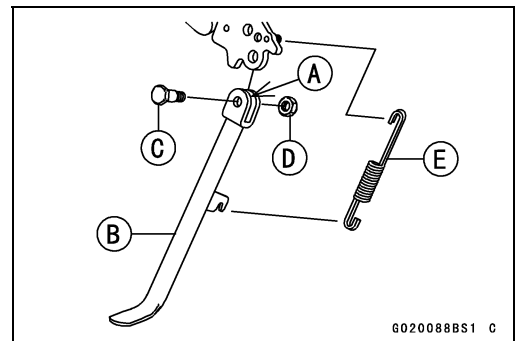

### BR125J

- Install the side stand switch [A].
- Insert the projection [B] into the hole [C].
- Fit the slit [D] to the projection [E].
- Apply a non-permanent locking agent to the side stand switch bolt, and tighten it.
- Inspect the side stand switch (see Side Stand Switch Operation Inspection in the Periodic Maintenance chapter).

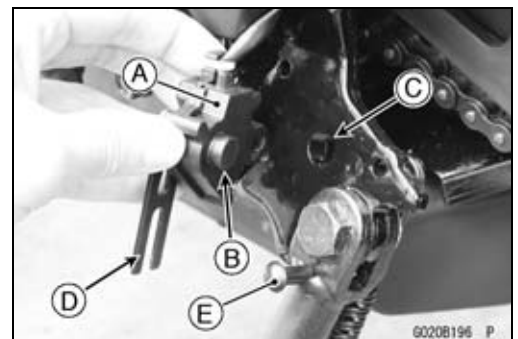

## 14-24 FRAME

### Rear View Mirrors

#### Rear View Mirror Removal

##### PH and TH Models

- Loosen the locknut [A], and remove the rear view mirror [B].

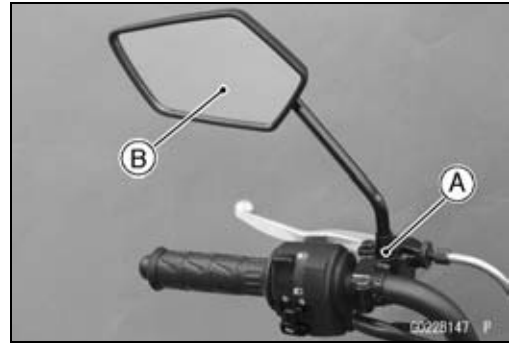

##### Other than PH and TH Models

- Slide the rubber boots [A].
- Loosen the rear view mirror locknut (upper) [B], and remove the rear view mirror stay [C] from the rear view mirror nut (lower) [D].
- The rear view mirror locknut (upper) and rear view mirror stay are left-hand threads.
- Loosen the rear view mirror nut (lower), and remove it.

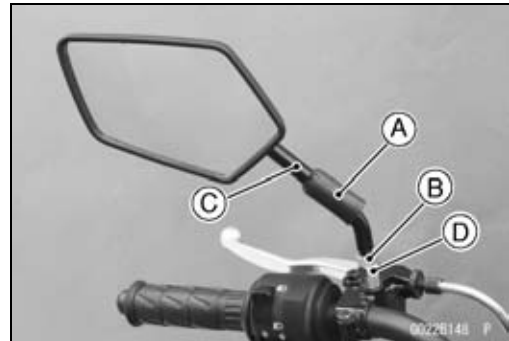

#### Rear View Mirror Installation

##### PH and TH Models

- Install the rear view mirror, and tighten the locknut [A].
- Adjust the rear view mirror slightly with its mirror [B].
- Installation and adjustment of the right side are common with those of the left side. Follow the procedure specified at the left side.

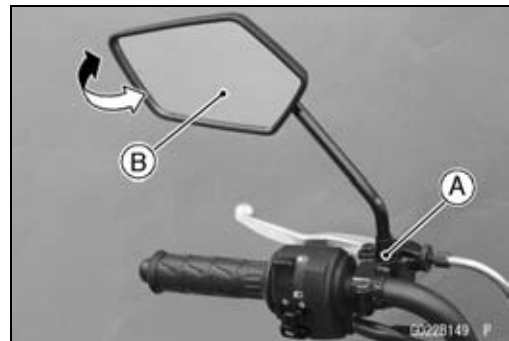

##### Other than PH and TH Models

- Tighten the rear view mirror nut (lower) [A].
- Apply grease to the threads of the rear view mirror stay [B].

#### NOTE

○ The threads of the new rear view mirror stay applied with a grease.

- Tighten the rear view mirror stay until the fully position.
- Adjust the rear view mirror stay to assure the safe conditions of the rear with the rider sitting on the motorcycle.
- The rear view mirror locknut (upper) [C] and rear view mirror stay are left-hand threads.
- Tighten the rear view mirror locknut (upper).
- Install the rubber boots [D].
- Adjust the rear view mirror [E] by slightly moving only the mirror portion of the assembly.
- Installation and adjustment of the right side are common with those of the left side. Follow the procedure specified at the left side.

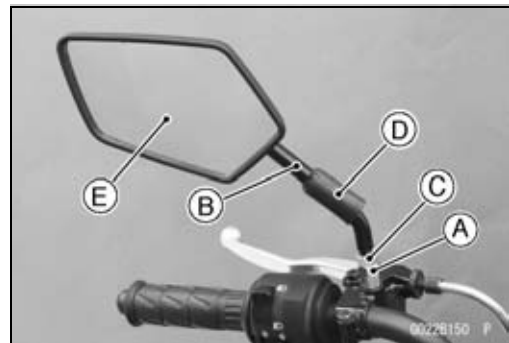



# Electrical System

## Table of Contents

Exploded View.....	15-4	Starter Motor Installation.....	15-47
Specifications .....	15-12	Starter Motor Disassembly.....	15-48
Special Tools and Sealant .....	15-13	Starter Motor Assembly .....	15-49
Parts Location.....	15-14	Brush Inspection .....	15-51
Wiring Diagram (BR125G).....	15-16	Commutator Cleaning and	
Wiring Diagram (BR125H).....	15-18	Inspection.....	15-51
Wiring Diagram (BR125J).....	15-20	Armature Inspection.....	15-52
Precautions.....	15-22	Brush Lead Inspection .....	15-52
Electrical Wiring.....	15-23	Right-hand End Cover Inspection	15-52
Wiring Inspection .....	15-23	Starter Relay Inspection.....	15-52
Battery .....	15-24	Lighting System.....	15-56
Battery Removal .....	15-24	Headlight Aiming Inspection .....	15-56
Battery Installation .....	15-24	Headlight Bulb Replacement .....	15-56
Battery Activation (Electrolyte not		Headlight Unit Removal	
Pre-filled Type Battery).....	15-25	(BR125G/H) .....	15-57
Precautions .....	15-27	Headlight Unit Removal	
Interchange .....	15-28	(BR125J).....	15-58
Charging Condition Inspection.....	15-28	Headlight Unit Installation	
Refreshing Charge.....	15-28	(BR125G/H) .....	15-59
Charging System.....	15-30	Headlight Unit Installation	
Alternator Cover Removal.....	15-30	(BR125J).....	15-59
Alternator Cover Installation.....	15-30	City Light Bulb Replacement.....	15-60
Stator Coil Removal .....	15-31	Tail/Brake Light (LED) Removal...	15-61
Stator Coil Installation .....	15-31	Tail/Brake Light (LED) Installation	15-61
Alternator Rotor Removal .....	15-32	License Plate Light Bulb	
Alternator Rotor Installation .....	15-32	Replacement.....	15-62
Charging Voltage Inspection .....	15-33	Turn Signal Light Bulb	
Alternator Inspection .....	15-34	Replacement.....	15-64
Regulator/Rectifier Removal .....	15-35	Meter, Gauge, Indicator Unit.....	15-66
Regulator/Rectifier Installation .....	15-35	Meter Unit Removal .....	15-66
Regulator/Rectifier Inspection.....	15-35	Meter Unit Installation .....	15-66
Ignition System.....	15-38	Meter Operation Inspection.....	15-66
Crankshaft Sensor Removal.....	15-38	Meter System Inspection .....	15-68
Crankshaft Sensor Installation.....	15-38	Meter Unit Inspection.....	15-69
Crankshaft Sensor Inspection.....	15-38	Fuel Level Sensor Line	
Crankshaft Sensor Peak Voltage		Self-Diagnosis Mode	
Inspection.....	15-39	Inspection.....	15-75
Ignition Coil Removal .....	15-39	Switches and Sensors .....	15-77
Ignition Coil Installation .....	15-40	Brake Light Timing Inspection.....	15-77
Ignition Coil Inspection.....	15-40	Brake Light Timing Adjustment ...	15-77
Ignition Coil Primary Peak Voltage		Switch Inspection .....	15-77
Inspection.....	15-41	Engine Temperature Sensor	
Spark Plug Removal .....	15-41	Inspection.....	15-78
Spark Plug Installation .....	15-41	Speed Sensor Removal.....	15-78
Spark Plug Condition Inspection..	15-42	Speed Sensor Installation .....	15-78
Interlock Operation Inspection		Speed Sensor Inspection.....	15-79
(BR125H/J) .....	15-42	Oxygen Sensor Removal.....	15-79
Diode Inspection .....	15-42	Oxygen Sensor Installation .....	15-79
Electric Starter System.....	15-47	Oxygen Sensor Inspection.....	15-79
Starter Motor Removal.....	15-47	Fuel Level Sensor Inspection.....	15-80

## 15-2 ELECTRICAL SYSTEM

---

Gear Position Switch Removal ....	15-80	Fuse.....	15-83
Gear Position Switch Installation .	15-80	Fuse Box Fuse Removal.....	15-83
Gear Position Switch Inspection ..	15-81	Fuse Installation.....	15-83
Relay .....	15-82	Fuse Inspection.....	15-83
Fuel Pump Relay Inspection .....	15-82		

This page intentionally left blank.

# 15-4 ELECTRICAL SYSTEM

## Exploded View

BR125G/H

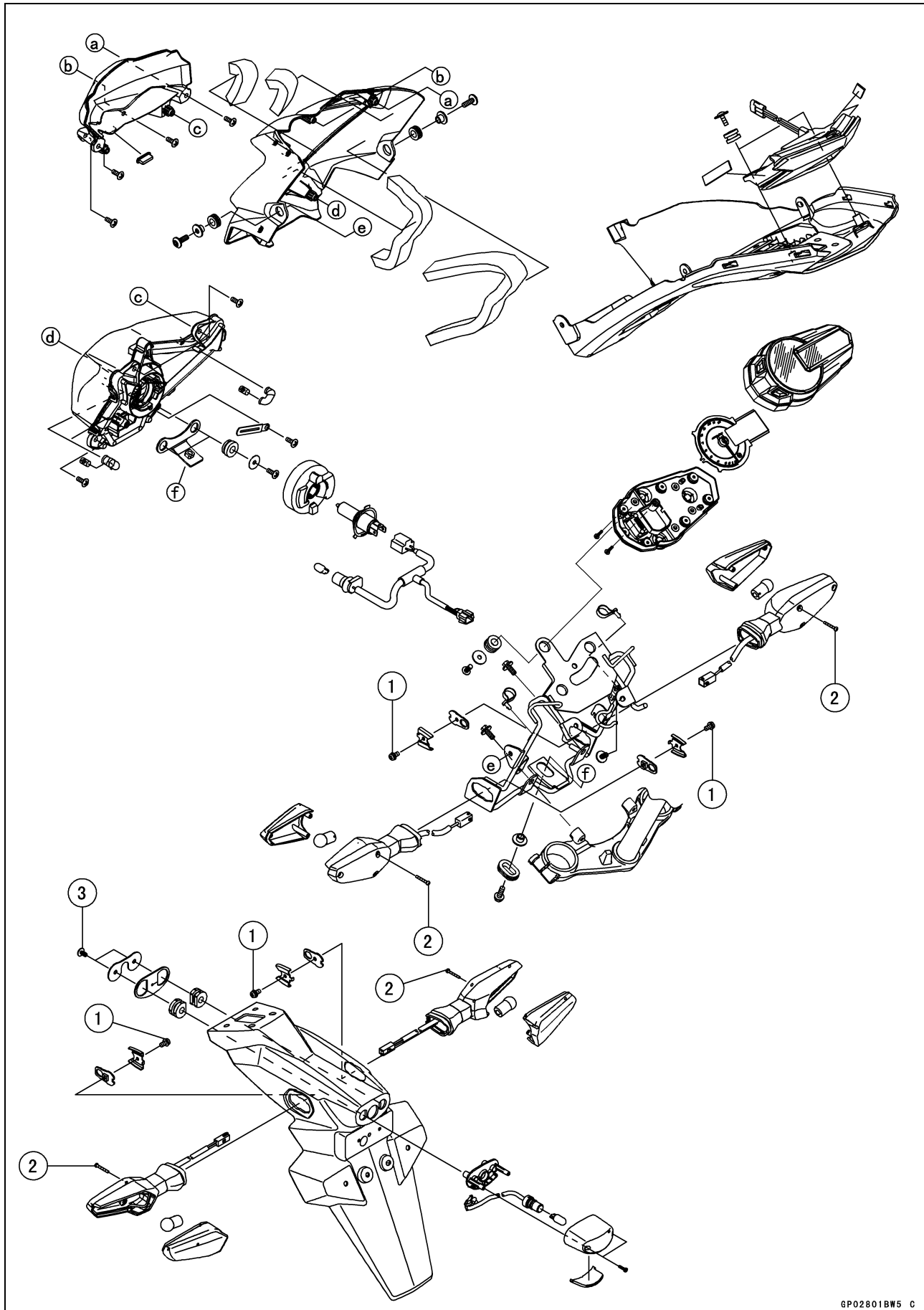

## ELECTRICAL SYSTEM 15-5

### Exploded View

No.	Fastener	Torque			Remarks
		N·m	kgf·m	ft·lb	
1	Turn Signal Light Bracket Screws	1.0	0.10	8.9 in·lb	
2	Turn Signal Light Lens Screws	1.0	0.10	8.9 in·lb	
3	License Plate Light Mounting Screws	1.5	0.15	13 in·lb	

# 15-6 ELECTRICAL SYSTEM

## Exploded View

BR125J

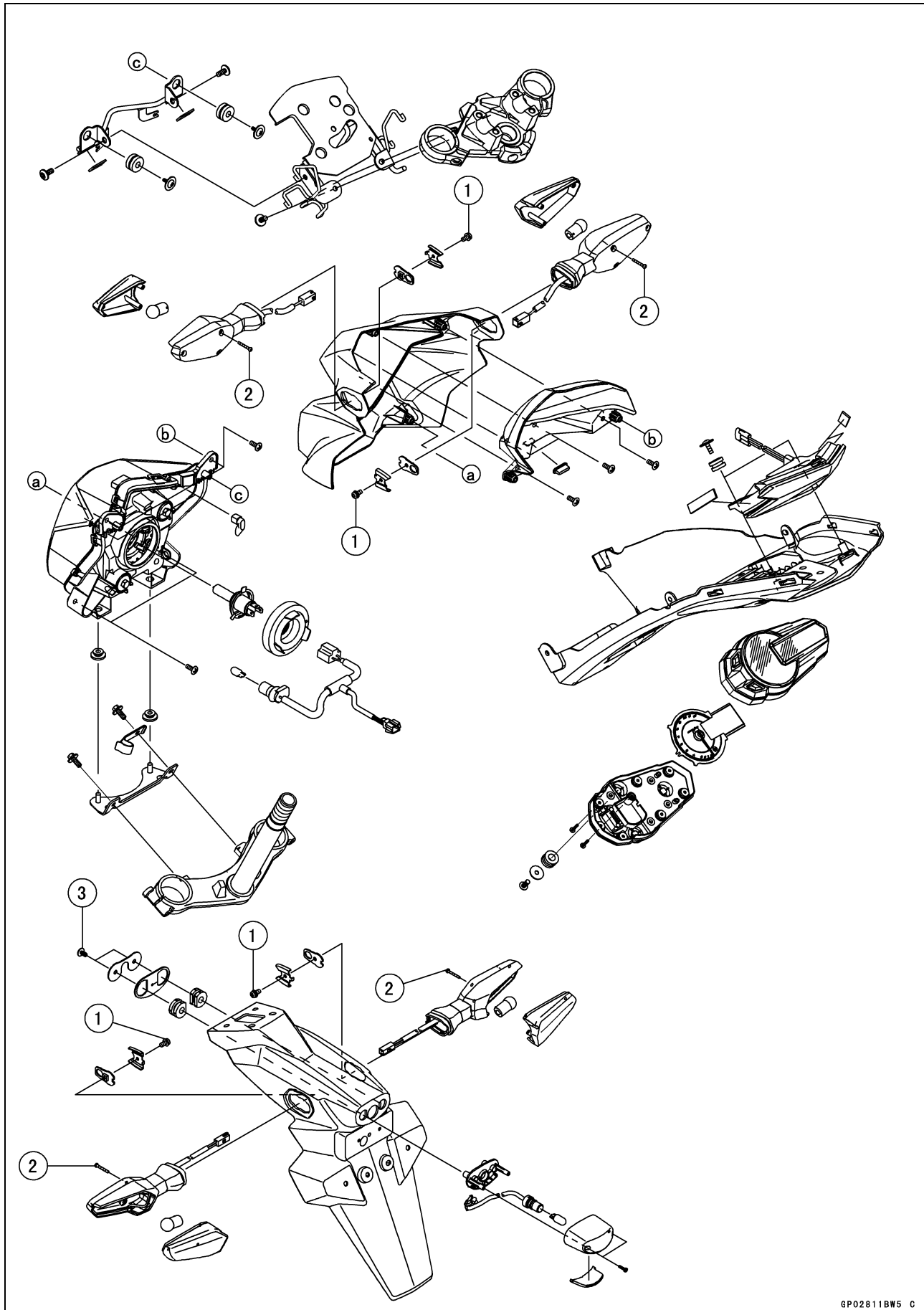

## ELECTRICAL SYSTEM 15-7

### Exploded View

No.	Fastener	Torque			Remarks
		N·m	kgf·m	ft·lb	
1	Turn Signal Light Bracket Screws	1.0	0.10	8.9 in·lb	
2	Turn Signal Light Lens Screws	1.0	0.10	8.9 in·lb	
3	License Plate Light Mounting Screws	1.5	0.15	13 in·lb	

# 15-8 ELECTRICAL SYSTEM

## Exploded View

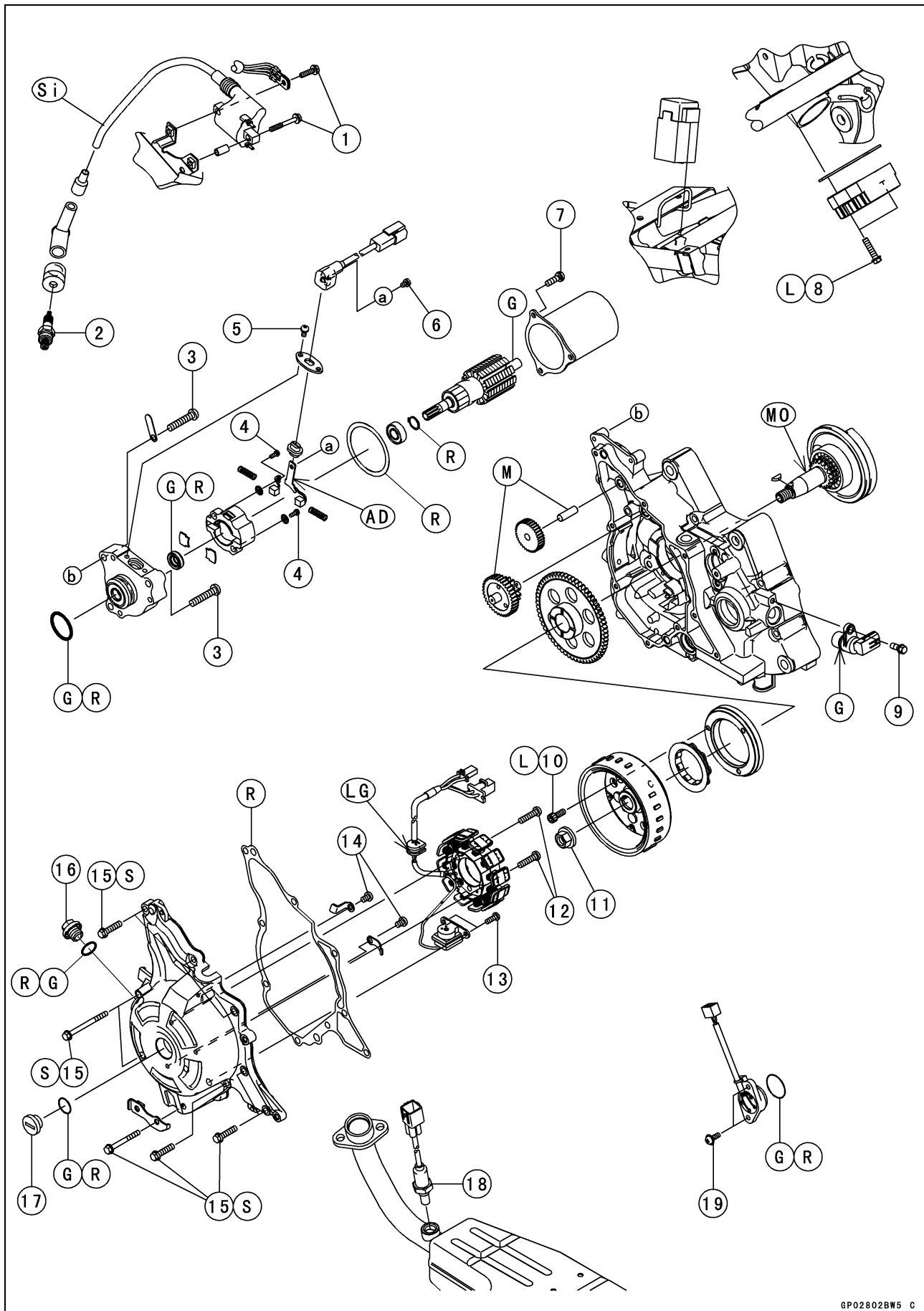



## Exploded View

No.	Fastener	Torque			Remarks
		N·m	kgf·m	ft·lb	
1	Ignition Coil Mounting Bolts	4.0	0.41	35 in·lb	
2	Spark Plug	13	1.3	115 in·lb	
3	Starter Motor Mounting Screws	5.2	0.53	46 in·lb	
4	Starter Motor Brush Holder Plate Screws	0.89	0.091	7.9 in·lb	
5	Starter Motor Terminal Plate Screws	2.0	0.20	18 in·lb	
6	Starter Motor Terminal Screw	2.0	0.20	18 in·lb	
7	Starter Motor End Cover Screws	4.4	0.45	39 in·lb	
8	Regulator/Rectifier Mounting Bolts	9.8	1.0	87 in·lb	L
9	Speed Sensor Bolt	5.2	0.53	46 in·lb	
10	Starter Motor Clutch Bolts	11.8	1.20	104 in·lb	L
11	Alternator Rotor Nut	53.9	5.50	39.8	
12	Stator Coil Mounting Screws	5.2	0.53	46 in·lb	
13	Crankshaft Sensor Mounting Screws	2.9	0.30	26 in·lb	
14	Alternator Lead Clamp Screws	5.2	0.53	46 in·lb	
15	Alternator Cover Bolts	8.8	0.90	78 in·lb	S
16	Timing Inspection Cap	2.4	0.24	21 in·lb	
17	Alternator Rotor Nut Cap	2.4	0.24	21 in·lb	
18	Oxygen Sensor	25	2.5	18	
19	Gear Position Switch Mounting Screws	2.9	0.30	26 in·lb	

AD: Apply adhesive.

G: Apply grease.

L: Apply a non-permanent locking agent.

LG: Apply liquid gasket.

M: Apply molybdenum disulfide grease.

MO: Apply molybdenum disulfide oil solution.

(mixture of the engine oil and molybdenum disulfide grease in a weight ratio 10:1)

R: Replacement Parts

S: Follow the specified tightening sequence.

Si: Apply silicone grease.

# 15-10 ELECTRICAL SYSTEM

## Exploded View

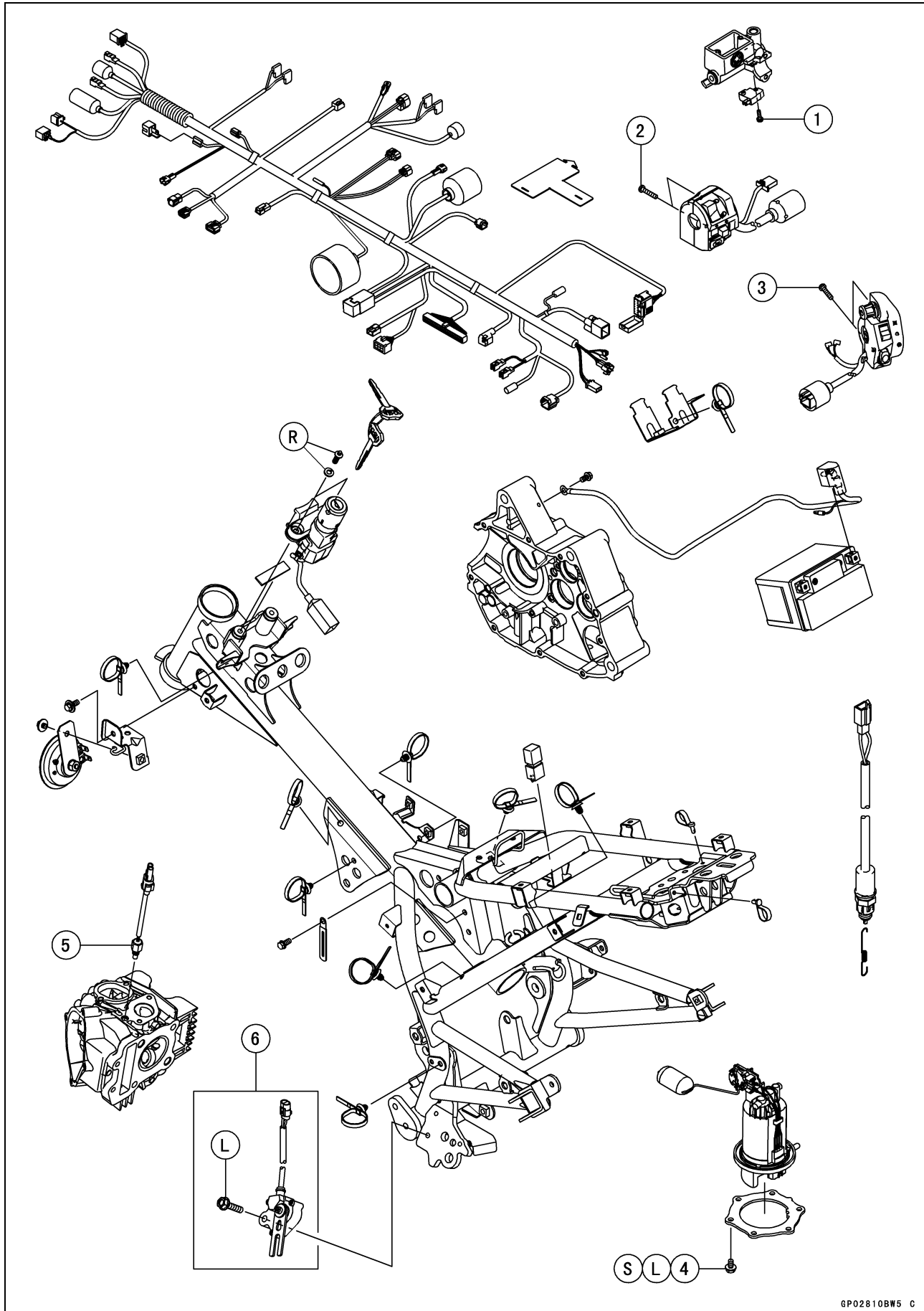

**Exploded View**

No.	Fastener	Torque			Remarks
		N·m	kgf·m	ft·lb	
1	Front Brake Light Switch Screw	1.2	0.12	11 in·lb	
2	Left Switch Housing Screws	3.5	0.36	31 in·lb	
3	Right Switch Housing Screws	3.5	0.36	31 in·lb	
4	Fuel Pump Bolts	9.8	1.0	87 in·lb	L, S
5	Engine Temperature Sensor	9.8	1.0	87 in·lb	

6. BR125J

L: Apply a non-permanent locking agent.

R: Replacement Parts

S: Follow the specified tightening sequence.

# 15-12 ELECTRICAL SYSTEM

## Specifications

Item	Standard
<b>Battery</b> Type Model Name Capacity Voltage Gross Weight Electrolyte Volume	Sealed Battery (Other than TH Model) FTH4L-BS (TH Model) FTZ4V 12 V 3 Ah (10 HR) 12.6 V or more 1.4 kg (3.1 lb) (Other than TH Model) 0.18 L (11 cu in.) (TH Model) 0.20 L (12 cu in.)
<b>Charging System</b> Type Alternator Output Voltage (no load) Stator Coil Resistance Charging Voltage (Regulator/Rectifier Output Voltage)	Single-phase AC AC 70 V or more @4 000 r/min (rpm) 0.2 ~ 0.7 $\Omega$ @20°C (68°F) DC 14.2 ~ 14.8 V
<b>Ignition System</b> Crankshaft Sensor: Resistance Peak Voltage Ignition Coil: Primary Winding Resistance Secondary Winding Resistance Primary Peak Voltage Spark Plug: Type Gap Cap Resistance	100 ~ 140 $\Omega$ @20°C (68°F) 3.5 V or more 2.07 ~ 2.53 $\Omega$ 7.44 ~ 11.2 k $\Omega$ 155 V or more NGK CR6HSA 0.6 ~ 0.7 mm (0.024 ~ 0.028 in.) 3.75 ~ 6.25 k $\Omega$ @20°C (68°F)
<b>Electric Starter System</b> Starter Motor: Brush Length Commutator Diameter	7 mm (0.28 in.) [Service Limit: 3.5 mm (0.14 in.)] 22 mm (0.87 in.) [Service Limit: 21.5 mm (0.846 in.)]
<b>Switches and Sensors</b> Rear Brake Light Switch Timing Engine Temperature Resistance Fuel Level Sensor Resistance: Full Position Empty Position	ON after about 10 mm (0.39 in.) of pedal travel in the text 8.6 ~ 11.4 $\Omega$ 246 ~ 254 $\Omega$

**Special Tools and Sealant**

**Rotor Puller M18 × 1.5, M16 × 1.5:  
57001-1099**

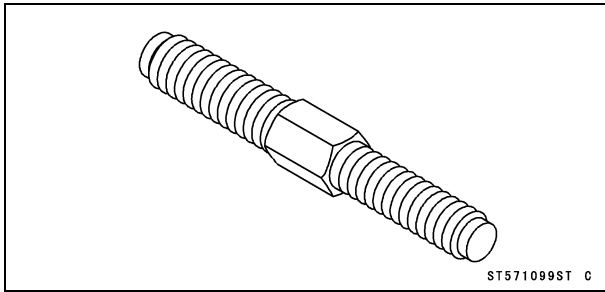

**Needle Adapter Set:  
57001-1457**

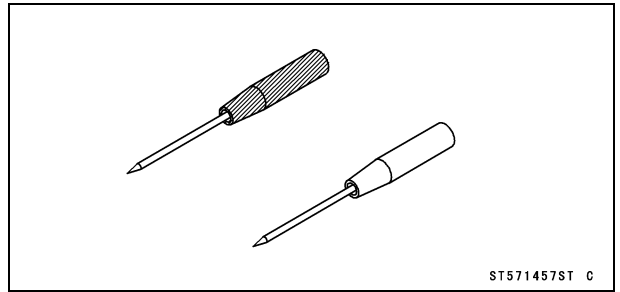

**Flywheel Holder:  
57001-1313**

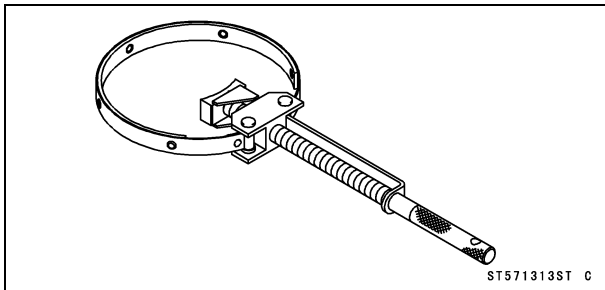

**Flywheel Puller, M28 × 1.0:  
57001-1471**

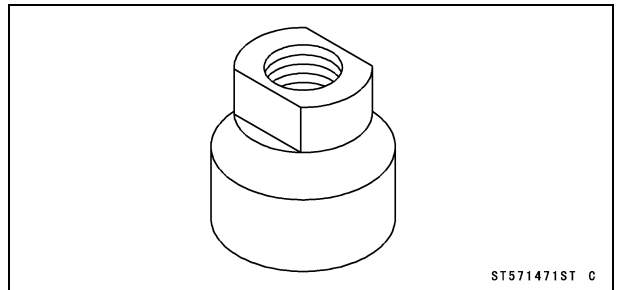

**Peak Voltage Adapter:  
57001-1415**

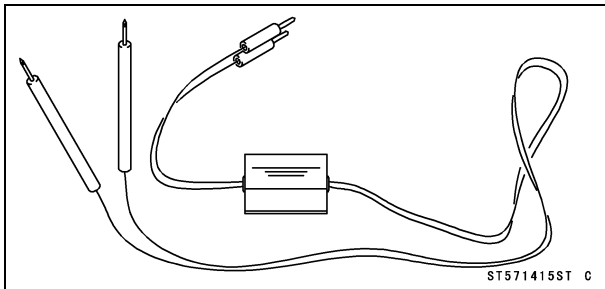

**Liquid Gasket, TB1211F:  
92104-0004**

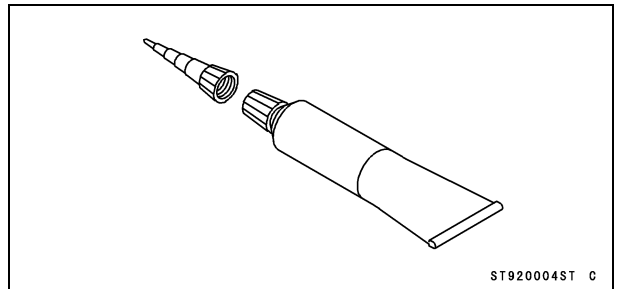

# 15-14 ELECTRICAL SYSTEM

## Parts Location

Starter Lockout Switch [A] (BR125H/J)  
Meter Unit [B]  
Front Brake Light Switch [C]  
Ignition Switch [D]

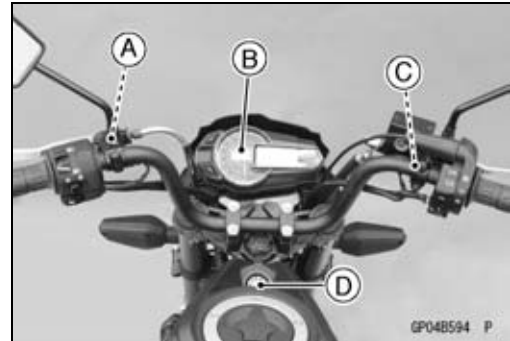

Horn [A]  
Diode (1) [B]

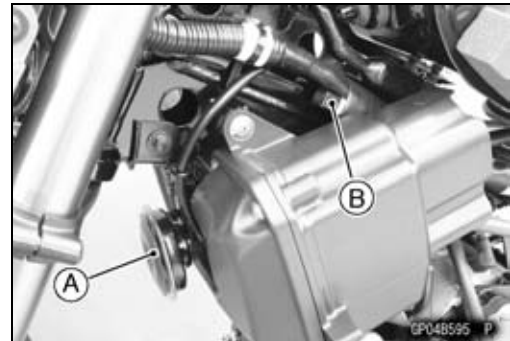

Gear Position Switch [A]  
Crankshaft Sensor [B]  
Alternator [C]  
Diode (2) [D] (BR125H)

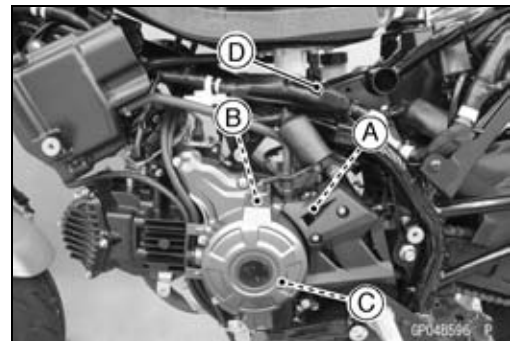

Regulator/Rectifier [A]  
Speed Sensor [B]

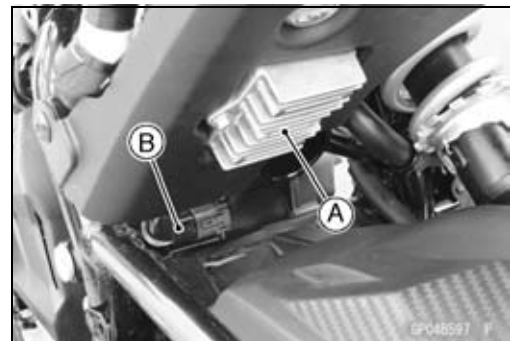

Diode (2) [A] (BR125J)  
ECU [B]  
Battery 12 V 3 Ah [C]  
Fuse Box [D]  
Starter Relay [E]

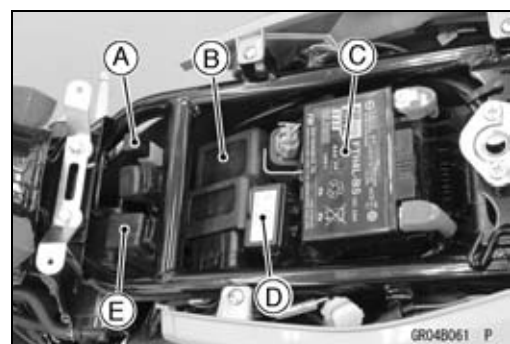

## Parts Location

- Frame Ground [A]
- Fuel Pump (Fuel Level Sensor) [B]
- Ignition Coil [C]
- Rear Brake Light Switch [D]
- Oxygen Sensor [E]
- Engine Ground [F]
- Spark Plug [G]
- Starter Motor [H]

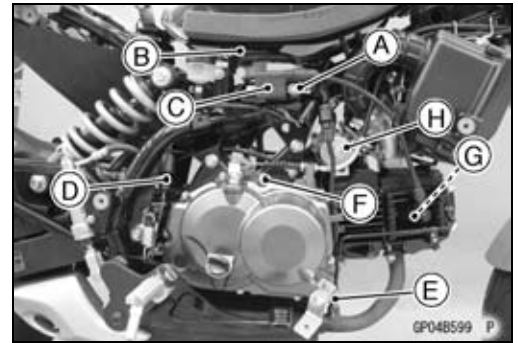

# 15-16 ELECTRICAL SYSTEM

## Wiring Diagram (BR125G)

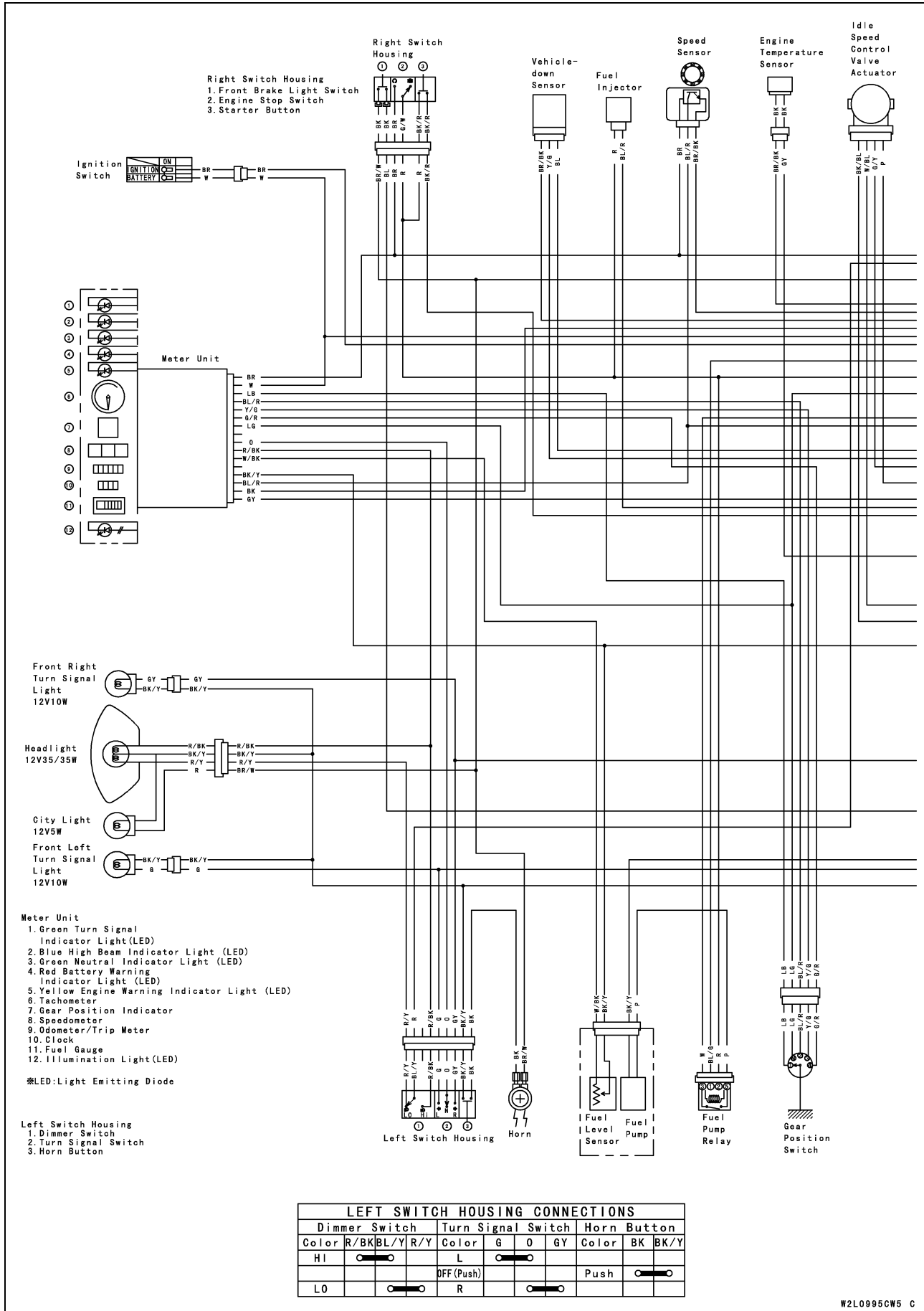



## Wiring Diagram (BR125G)

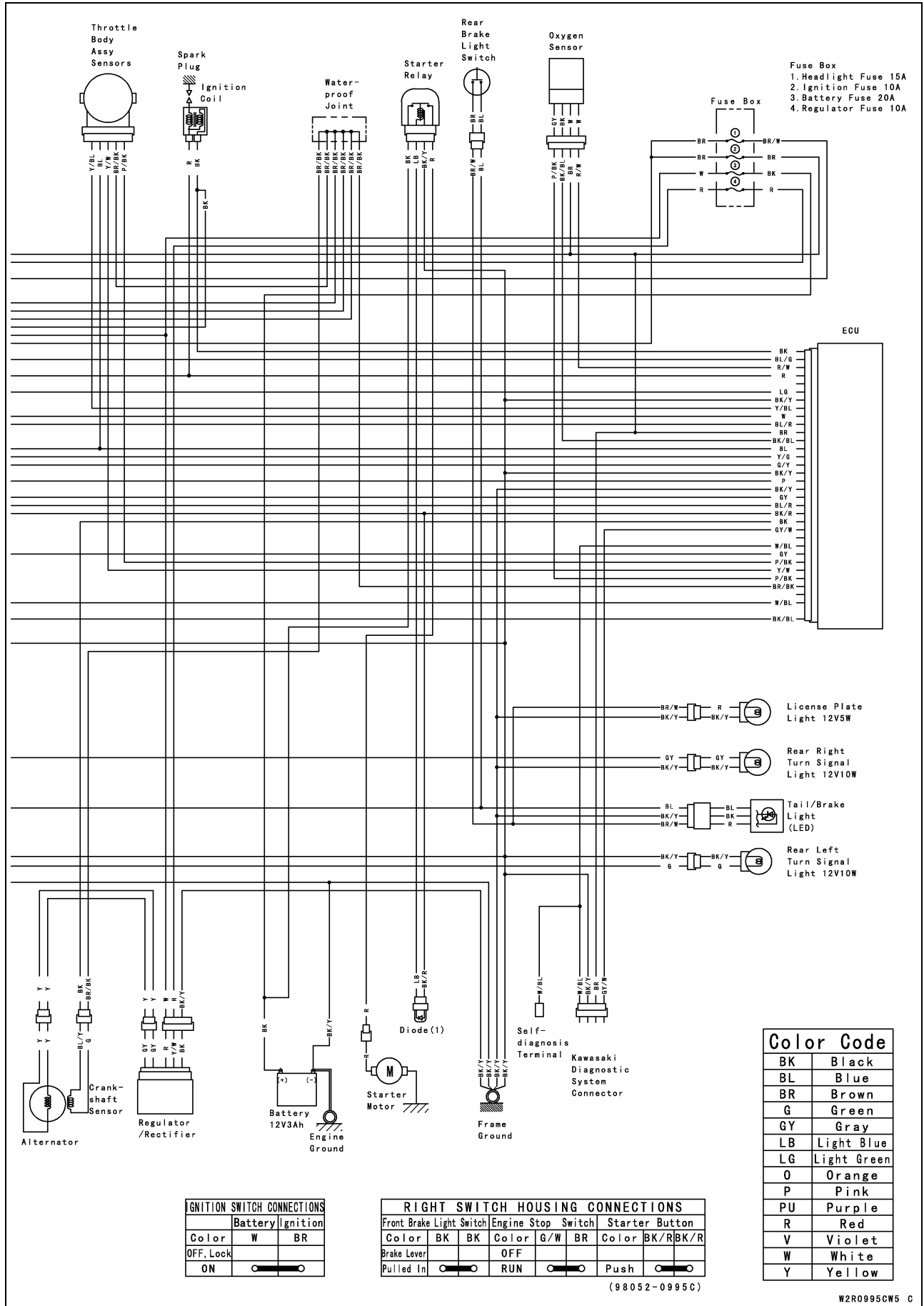

# 15-18 ELECTRICAL SYSTEM

## Wiring Diagram (BR125H)

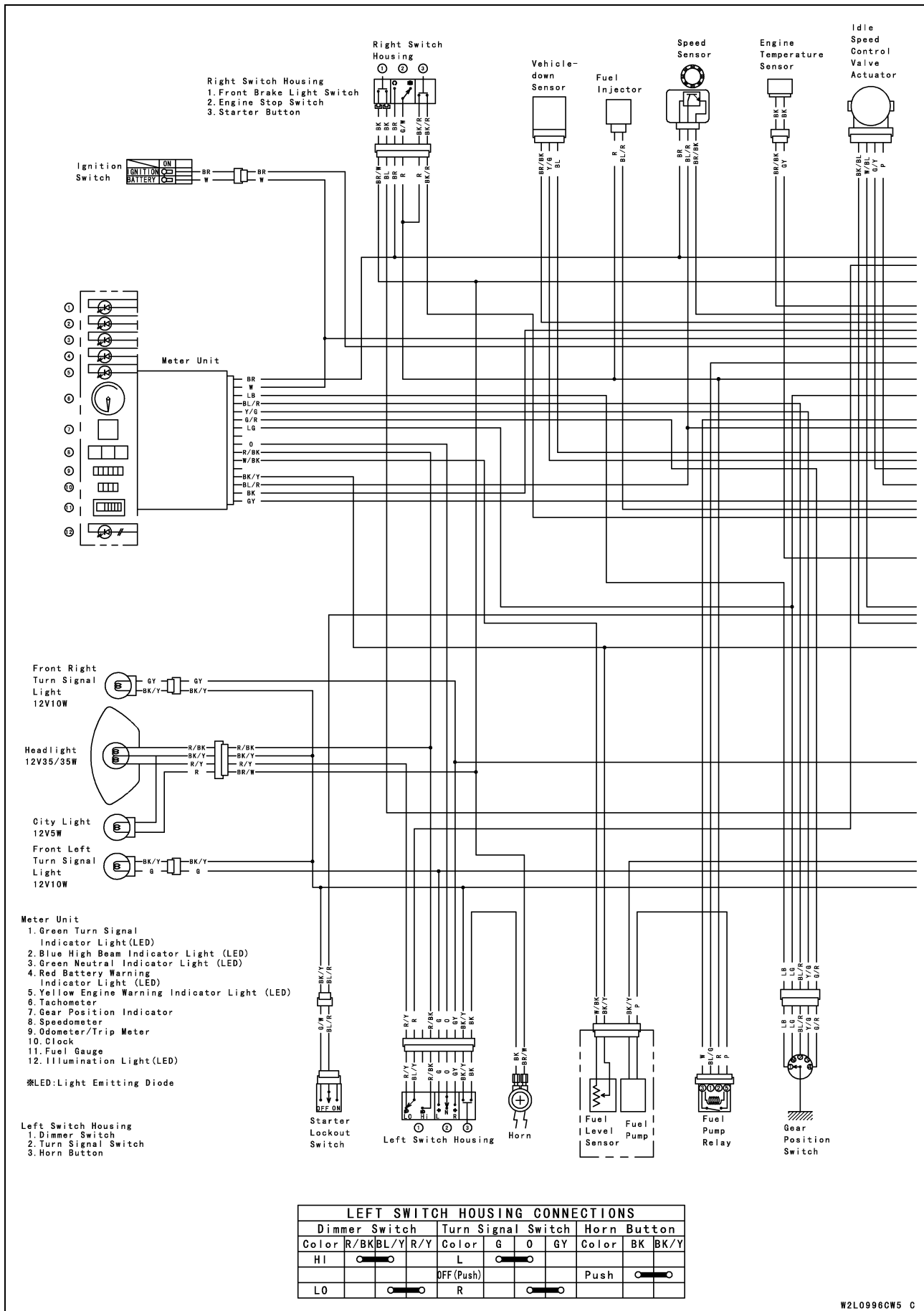

## Wiring Diagram (BR125H)

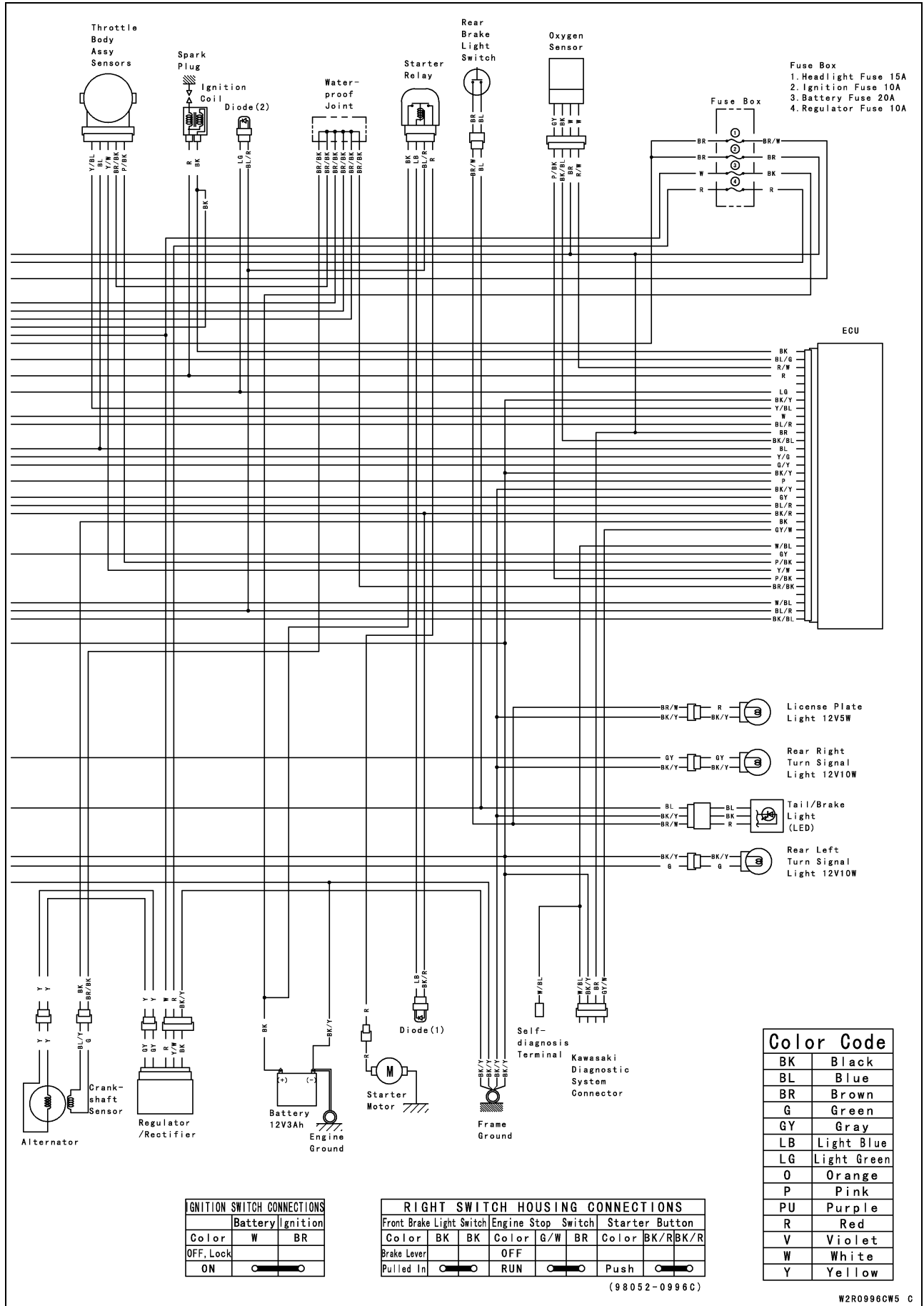

# 15-20 ELECTRICAL SYSTEM

## Wiring Diagram (BR125J)

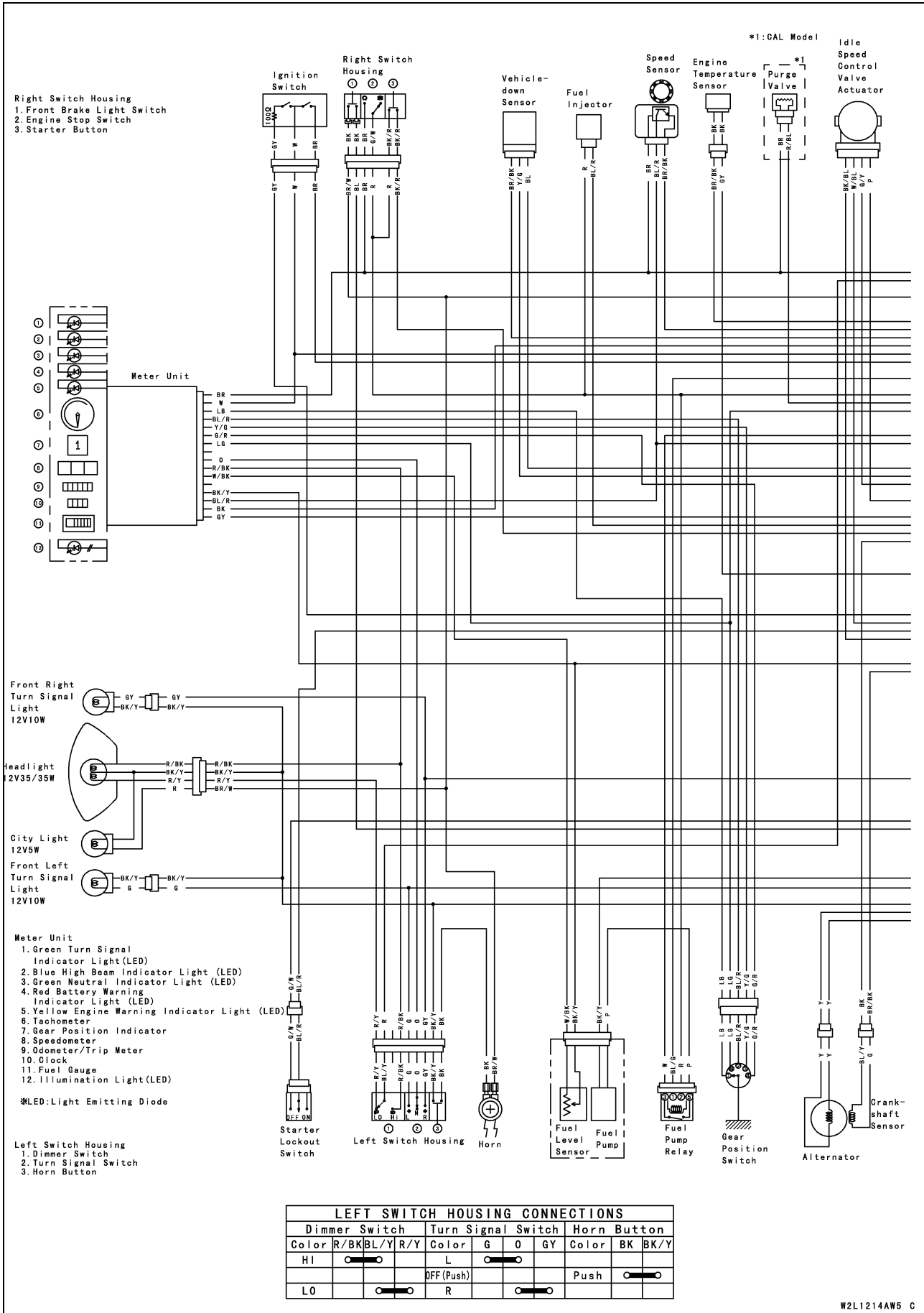

## Wiring Diagram (BR125J)

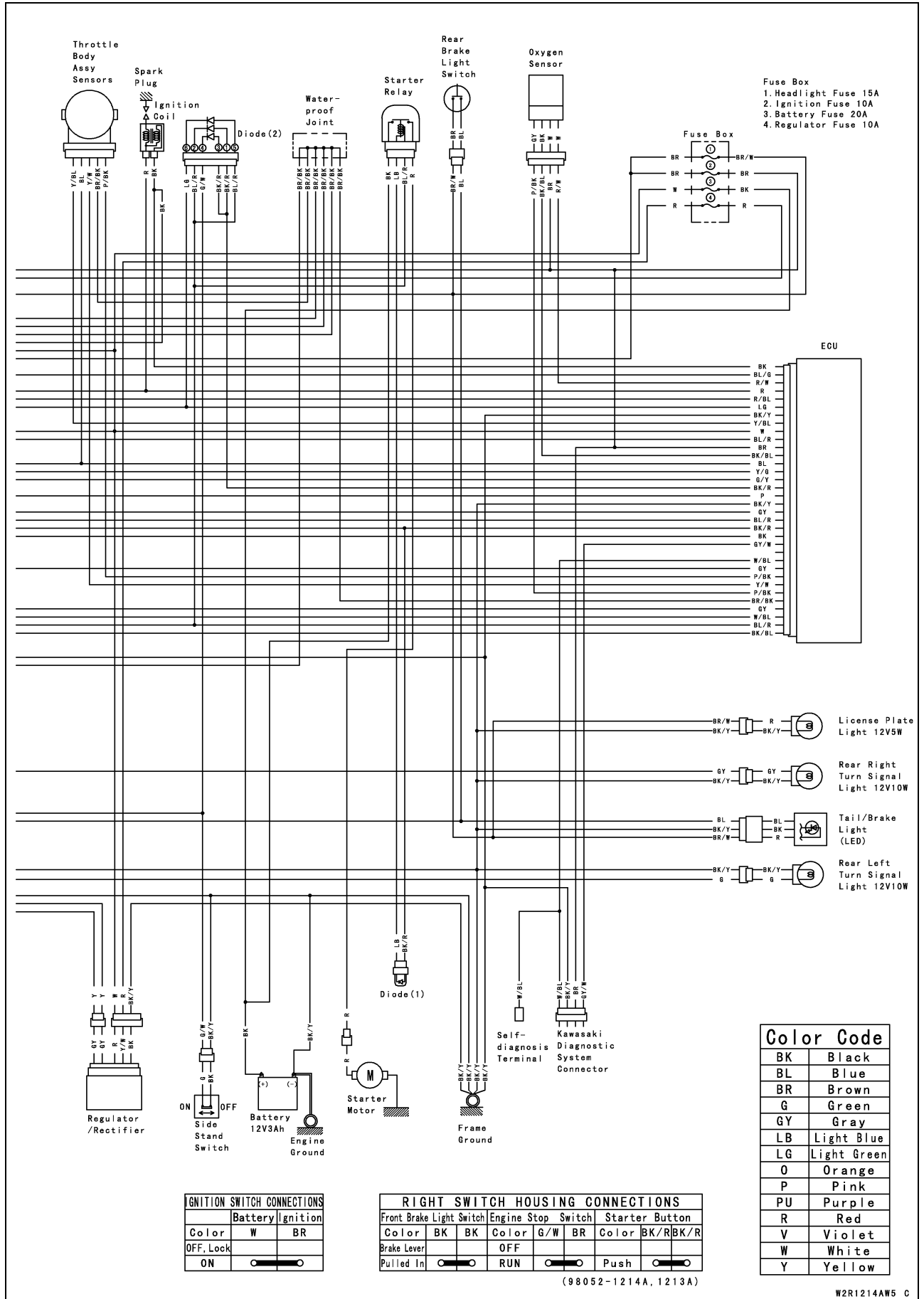

## 15-22 ELECTRICAL SYSTEM

---

### Precautions

---

There are a number of important precautions that are musts when servicing electrical systems. Learn and observe all the rules below.

- Do not reverse the battery cable connections. This will burn out the diodes on the electrical parts.
- Always check battery condition before condemning other parts of an electrical system. A fully charged battery is a must for conducting accurate electrical system tests.
- The electrical parts should never be struck sharply, as with a hammer, or allowed to fall on a hard surface. Such a shock to the parts can damage them.
- To prevent damage to electrical parts, do not disconnect the battery cables or any other electrical connections when the ignition switch is on, or while the engine is running.
- Because of the large amount of current, never keep the starter button pushed when the starter motor will not turn over, or the current may burn out the starter motor windings.
- Take care not to short the cables that are directly connected to the battery positive (+) terminal to the chassis ground.
- Troubles may involve one or in some cases all items. Never replace a defective part without determining what CAUSED the failure. If the failure was caused by some other item or items, they must be repaired or replaced, or the new replacement will soon fail again.
- Make sure all connectors in the circuit are clean and tight, and examine wires for signs of burning, fraying, etc. Poor wires and bad connections will affect electrical system operation.
- Measure coil and winding resistance when the part is cold (at room temperature).

## Electrical Wiring

### Wiring Inspection

- Visually inspect the wiring for signs of burning, fraying, etc.
- ★ If any wiring is poor, replace the damaged wiring.
- Pull each connector [A] apart and inspect it for corrosion, dirt, and damage.
- ★ If the connector is corroded or dirty, clean it carefully. If it is damaged, replace it.
- Check the wiring for continuity.
- Use the wiring diagram to find the ends of the lead which is suspected of being a problem.
- Connect a tester between the ends of the leads.
- ★ If the tester does not read about  $0 \Omega$ , the lead is defective. Replace the lead or the wiring harness [B] if necessary.

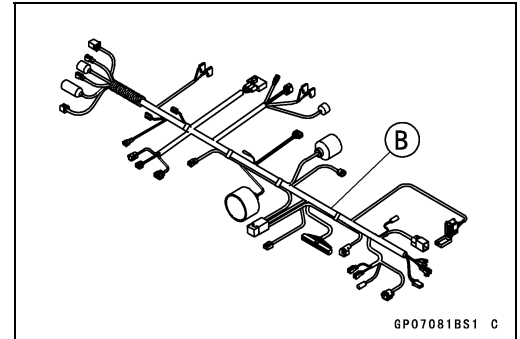
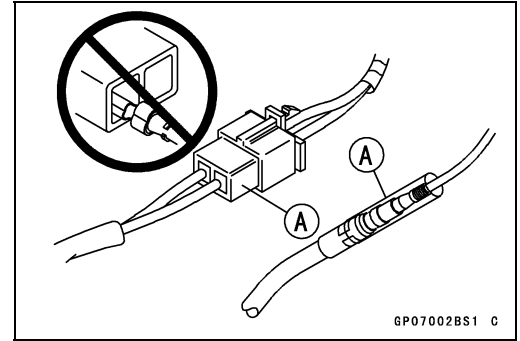

## 15-24 ELECTRICAL SYSTEM

### Battery

#### Battery Removal

- Turn the ignition switch off.
- Remove the seat (see Seat Removal in the Frame chapter).
- Slide out the negative (-) terminal cap [A] and disconnect the negative (-) cable [B].

#### NOTICE

**Be sure to disconnect the negative (-) cable first.**

- Slide out the positive (+) terminal cap [C] and disconnect the positive (+) cable [D].
- Remove the battery [E].

#### Battery Installation

- Turn the ignition switch off.
- Check that the dampers [A] are in place on the rear fender.

- Put the battery into the storage box.
- Run the positive (+) cable and negative (-) cable correctly (see Cable, Wire, and Hose Routing section in the Appendix chapter).
- Install the positive (+) cable [A] first.
- Install the negative (-) cable [B].
- Apply a light coat of grease on the terminals to prevent corrosion.
- Cover the both terminals with each cap.

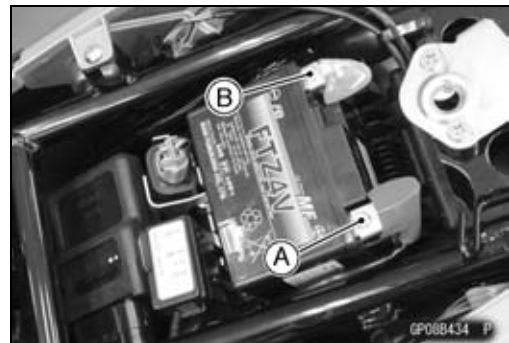
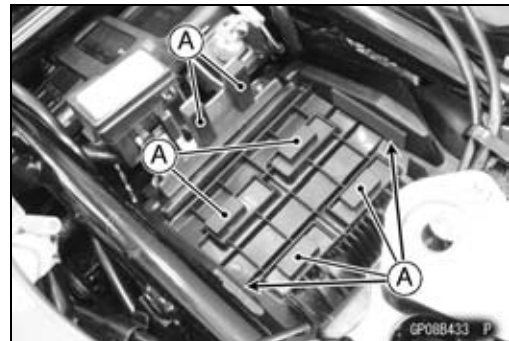
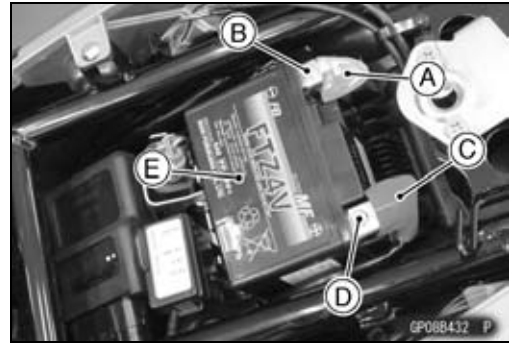

#### Comparison of Sealed Battery

	TH Model	Other than TH Models
<b>Battery Model</b>	FTZ4V	FTH4L-BS
<b>Electrolyte Filling</b>	Pre-filled	not Pre-filled
<b>Top Sealing</b>	sealed	use seal plug before activation
<b>Initial Charge</b>	unnecessary	necessary
<b>Activation</b>	unnecessary	necessary
<b>Electrolyte Maintenance</b>	unnecessary	unnecessary



## Battery

### Battery Activation (Electrolyte not Pre-filled Type Battery)

#### Electrolyte Filling

- Make sure that the model name [A] of the electrolyte container matches the model name [B] of the battery. These names must be the same.

#### Battery Model Name

BR125G/H: FTH4L-BS

#### NOTICE

Each battery comes with its own specific electrolyte container; using the wrong container may overfill the battery with incorrect electrolyte, which can shorten battery life and deteriorate battery performance. Be sure to use the electrolyte container with the same model name as the battery since the electrolyte volume and specific gravity vary with the battery type.

#### NOTICE

Do not remove the aluminum sealing sheet [A] from the filler ports [B] until just prior to use. Be sure to use the dedicated electrolyte container for correct electrolyte volume.

#### **⚠ DANGER**

Sulfuric acid in battery electrolyte can cause severe burns. To prevent burns, wear protective clothing and safety glasses when handling electrolyte. If the electrolyte comes in contact with your skin or eyes, wash the area with liberal amounts of water and seek medical attention for more severe burns.

- Place the battery on a level surface.
- Check to see that the sealing sheet has no peeling, tears, or holes in it.
- Remove the sealing sheet.

#### NOTE

○The battery is vacuum sealed. If the sealing sheet has leaked air into the battery, it may require a longer initial charge.

- Remove the electrolyte container from the vinyl bag.
- Detach the strip of caps [A] from the container and set aside, these will be used later to seal the battery.

#### NOTE

○Do not pierce or otherwise open the sealed cells [B] of the electrolyte container. Do not attempt to separate individual cells.

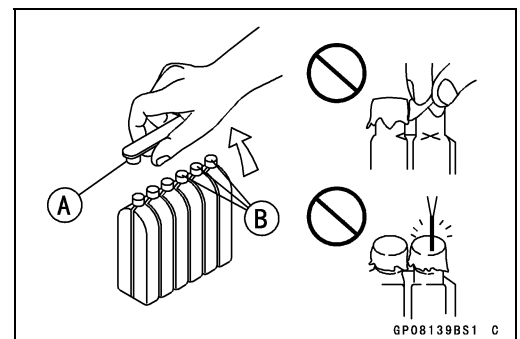
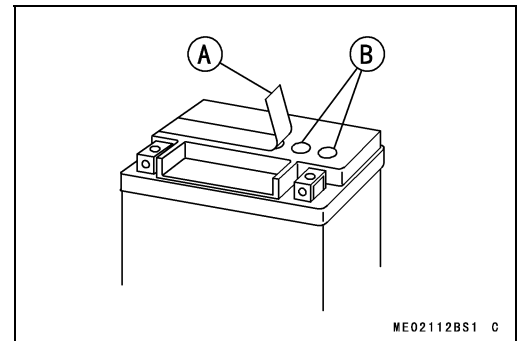
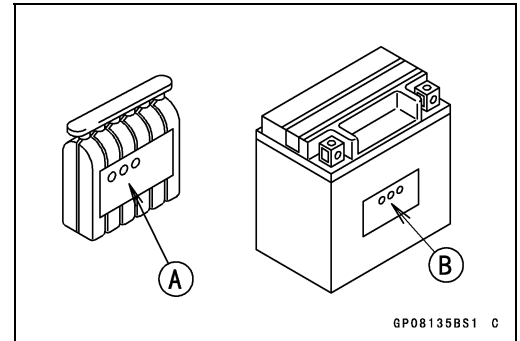

# 15-26 ELECTRICAL SYSTEM

## Battery

- Place the electrolyte container upside down with the six sealed cells into the filler ports of the battery. Hold the container level, push down to break the seals of all six cells. You will see air bubbles rising into each cell as the ports fill.

### NOTE

○Do not tilt the electrolyte container.

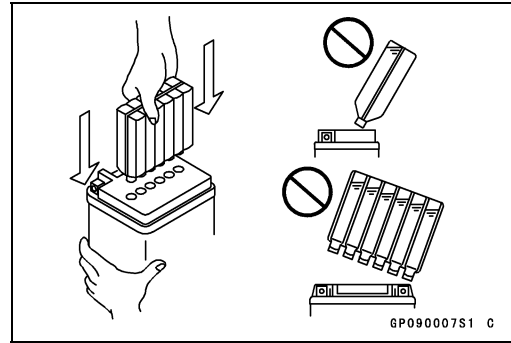

- Check the electrolyte flow.
- ★ If no air bubbles [A] are coming up from the filler ports, or if the container cells have not emptied completely, tap the container [B] a few times.

### NOTE

○Be careful not to have the battery fall down.

- Keep the container in place. Don't remove the container from the battery, the battery requires all the electrolyte from the container for proper operation.

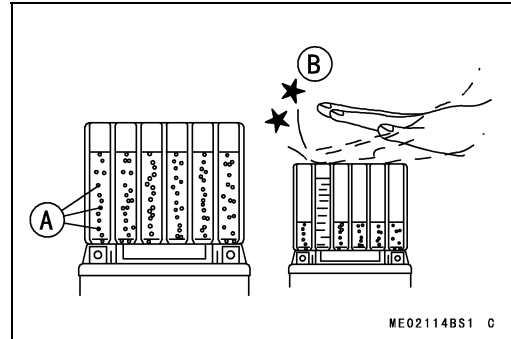

### NOTICE

**Removal of the container before it is completely empty can shorten the service life of the battery. Do not remove the container until it is completely empty.**

- After filling, let the battery sit for 20 ~ 60 minutes with the electrolyte container kept in place, which is required for the electrolyte to fully permeate into the plates.
- Make sure that the container cells have emptied completely, and remove the container from the battery.
- Place the strip of caps [A] loosely over the filler ports, press down firmly with both hands to seat the strip of caps into the battery (don't pound or hammer). When properly installed, the strip of caps will be level with the top of the battery.

### NOTICE

**Once the strip of caps is installed onto the battery, never remove the caps, nor add water or electrolyte to the battery.**

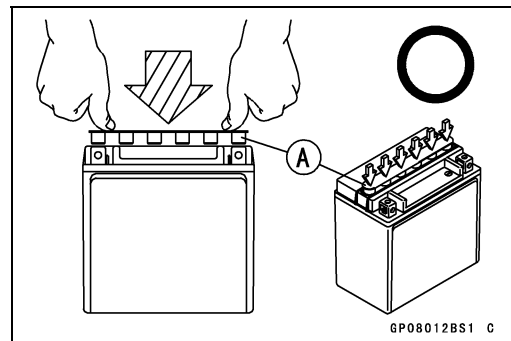

### NOTE

○Charging the battery immediately after filling can shorten service life.

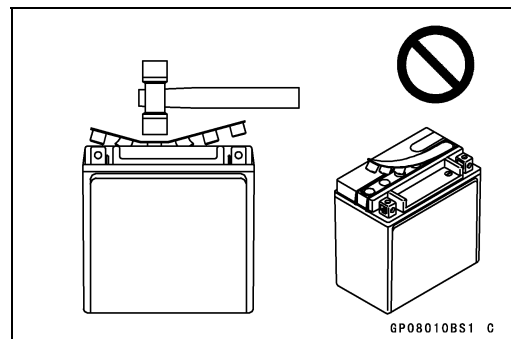

## Battery

### Initial Charge

- Newly activated sealed batteries require an initial charge.

**Standard Charge: 0.4 A × 5 ~ 10 hours**

- ★ If using a recommended battery charger, follow the charger's instructions for newly activated sealed battery.

#### Kawasaki-recommended chargers:

**Battery Mate 150-9**

**OptiMate PRO 4-S/PRO S/PRO2**

**Yuasa MB-2040/2060**

**Christie C10122S**

- ★ If the above chargers are not available, use equivalent one.
- Let battery sit 30 minutes after initial charge, then check voltage using a voltmeter. (Voltage immediately after charging becomes temporarily high. For accurate measuring, let the battery sit for given time.)

### NOTE

- *Charging rates will vary depending on how long the battery has been stored, temperature, and the type of charger used. If voltage is not at least 12.6 V, repeat charging cycle.*
- *To ensure maximum battery life and customer satisfaction, it is recommended the battery be load tested at three times its amp-hour rating for 15 seconds. Re-check voltage and if less than 12.6 V repeat the charging cycle and load test. If still below 12.6 V the battery is defective.*

### Precautions

- 1) No need of topping-up  
No topping-up is necessary in this battery until it ends its life under normal use. Forcibly prying off the seal cap to add water is very dangerous. Never do that.
- 2) Refreshing charge.  
If an engine will not start, a horn sounds weak, or lamps are dim, it indicates the battery has been discharged. Give refresh charge for 5 to 10 hours with charge current shown in the specification (see Refreshing Charge).  
When a fast charge is inevitably required, do it following precisely the maximum charge current and time conditions indicated on the battery.

### NOTICE

**This battery is designed to sustain no unusual deterioration if refresh-charged according to the method specified above. However, the battery's performance may be reduced noticeably if charged under conditions other than given above. Never remove the seal cap during refresh charge.**

**If by chance an excessive amount of gas is generated due to overcharging, the relief valve releases the gas to keep the battery normal.**

- 3) When you do not use the motorcycle for months.  
Give a refresh charge before you store the motorcycle and store it with the negative cable removed. Give a refresh charge **once a month** during storage.
- 4) Battery life.  
If the battery will not start the engine even after several refresh charges, the battery has exceeded its useful life. Replace it (Provided, however, the vehicle's starting system has no problem).

# 15-28 ELECTRICAL SYSTEM

## Battery

### **⚠ DANGER**

Batteries produce an explosive gas mixture of hydrogen and oxygen that can cause serious injury and burns if ignited. Keep the battery away from sparks and open flames during charging. When using a battery charger, connect the battery to the charger before turning on the charger. This procedure prevents sparks at the battery terminals which could ignite any battery gases. The electrolyte contains sulfuric acid. Be careful not to have it touch your skin or eyes. If touched, wash it off with liberal amount of water and seek medical attention for more severe burns.

### **Interchange**

A sealed battery can fully display its performance only when combined with a proper vehicle electric system. Therefore, replace a sealed battery only on a motorcycle which was originally equipped with a sealed battery.

Be careful, if a sealed battery is installed on a motorcycle which had an ordinary battery as original equipment, the sealed battery's life will be shortened.

### **Charging Condition Inspection**

- Battery charging condition can be checked by measuring battery terminal voltage with a digital meter [A].
- Remove:
  - Battery (see Battery Removal)
- Measure the battery terminal voltage.

#### **NOTE**

○ Measure with a digital voltmeter which can be read one decimal place voltage.

★ If the reading is 12.6 V or more, no refresh charge is required, however, if the read is below the specified, refresh charge is required.

#### **Battery Terminal Voltage**

Standard: 12.6 V or more

Terminal Voltage (V) [A]

Battery Charge Rate (%) [B]

Refresh charge is required [C]

Note [D]

Good [E]

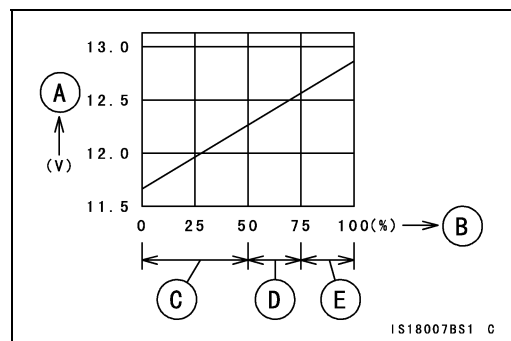
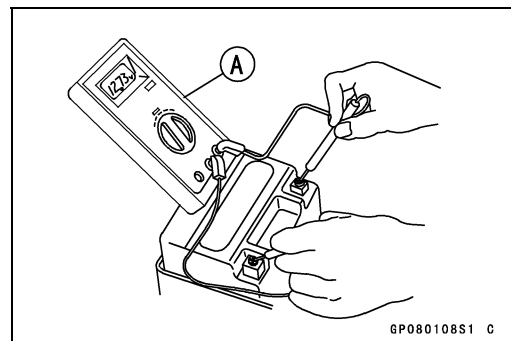

### **Refreshing Charge**

- Remove the battery [A] (see Battery Removal).
- Do refresh charge by following method according to the battery terminal voltage.

### **⚠ WARNING**

This battery is sealed type. Never remove sealing cap [B] even at charging. Never add water. Charge with current and time as stated below.

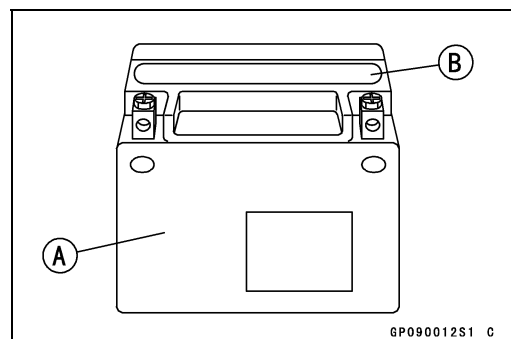

**Battery**

**Terminal Voltage: 11.5 ~ 12.6 V**  
**Standard Charge (see following chart):** FTZ4V: 0.3 A × 5 ~ 10 h  
 FTH4L-BS: 0.4 A × 5 ~ 10 h  
**Quick Charge** FTZ4V: 3 A × 0.5 h  
 FTH4L-BS: 4 A × 0.5 h

**NOTICE**

**If possible, do not quick charge. If quick charge is done unavoidably, do standard charge later on.**

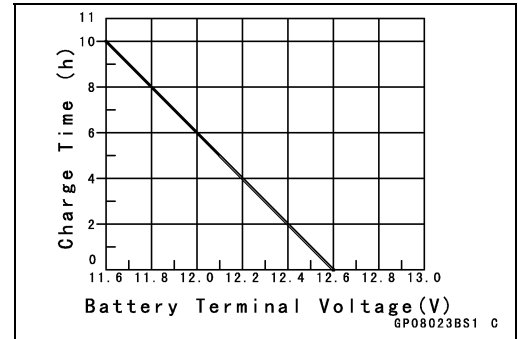

**Terminal Voltage: lower than 11.5 V**  
**Charging Method:** FTZ4V: 0.3 A × 20 h  
 FTH4L-BS: 0.4 A × 20 h

**NOTE**

○ Increase the charging voltage to a maximum voltage of 25 V if the battery will not accept current initially. Charge for no more than 5 minutes at the increased voltage then check if the battery is drawing current. If the battery will accept current decrease the voltage and charge by the standard charging method described on the battery case. If the battery will not accept current after 5 minutes, replace the battery.

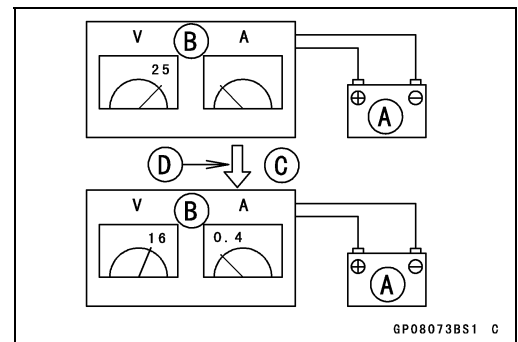

Battery [A]  
 Battery Charger [B]  
 Standard Value [C]  
 Current starts to flow [D].

- Determine the battery condition after refresh charge.
- Determine the condition of the battery left for 30 minutes after completion of the charge by measuring the terminal voltage according to the table below.

Criteria	Judgement
12.6 V or higher	Good
12.0 ~ lower than 12.6 V	Charge insufficient → Recharge
lower than 12.0 V	Unserviceable → Replace

## 15-30 ELECTRICAL SYSTEM

### Charging System

#### **Alternator Cover Removal**

- Drain the engine oil (see Engine Oil Change in the Periodic Maintenance chapter).
- Remove:
  - Engine Sprocket Cover (see Engine Sprocket Removal in the Final Drive chapter)
  - Lower Fairing (see Lower Fairing Removal in the Frame chapter)
- Disconnect the alternator and crankshaft sensor lead connectors [A].
- Remove the bolts [B], lower fairing bracket [C] and pull out the alternator cover [D].
- Remove the gasket and dowel pins from the crankcase.

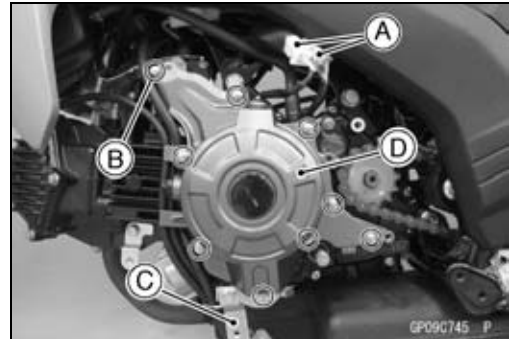

#### **Alternator Cover Installation**

- Make sure that the starter motor idle gear [A] and shaft [B] are securely installed.

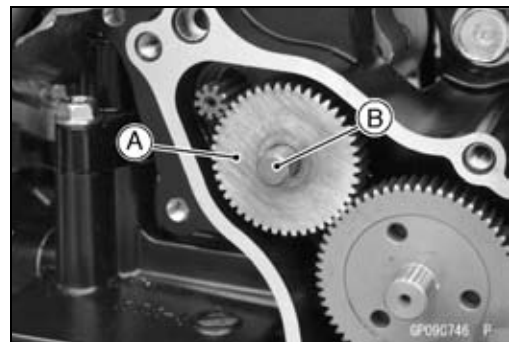

- Replace the gasket [A] with a new one.
- Install the dowel pins [B] and gasket in place.

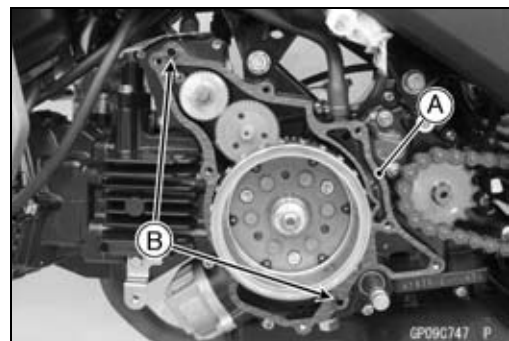

- Using a high flash-point solvent, clean off any oil or dirt that may be on the liquid gasket coating area. Dry them with a clean cloth.
- Apply liquid gasket to the mating surface on the wiring grommet [A].

**Sealant - Liquid Gasket, TB1211F: 92104-0004**

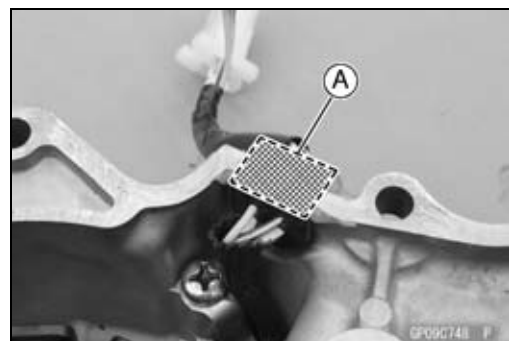

## Charging System

- Install the alternator cover [A] and lower fairing bracket [B].
- Tighten the alternator cover bolts following the specified tightening sequence [1 ~ 12].

**Torque - Alternator Cover Bolts: 8.8 N·m (0.90 kgf·m, 78 in·lb)**

- Run the alternator lead correctly (see Cable, Wire, and Hose Routing section in the Appendix chapter).
- Connect the alternator and crankshaft sensor lead connectors.
- Install the removed parts (see appropriate chapters).
- Pour in the specified type and amount of oil (see Engine Oil Change in the Periodic Maintenance chapter).

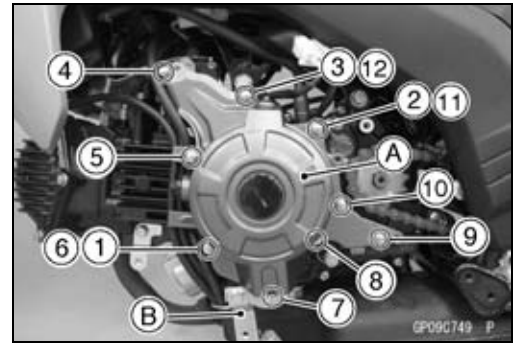

### Stator Coil Removal

- Remove:
  - Alternator Cover (see Alternator Cover Removal)
  - Alternator Lead Clamp Screws [A]
  - Alternator Lead Clamps [B]
  - Crankshaft Sensor Mounting Screws [C]
  - Stator Coil Mounting Screws [D]
- Pull the wiring grommet [E].
- Remove the crankshaft sensor and the stator coil as a set.

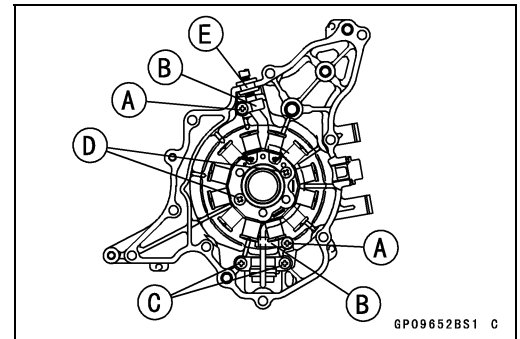

### Stator Coil Installation

- Install:
  - Stator Coil [A]
  - Crankshaft Sensor [B]
- Tighten:
  - Torque - Stator Coil Mounting Screws: 5.2 N·m (0.53 kgf·m, 46 in·lb)**
  - Crankshaft Sensor Mounting Screws: 2.9 N·m (0.30 kgf·m, 26 in·lb)**

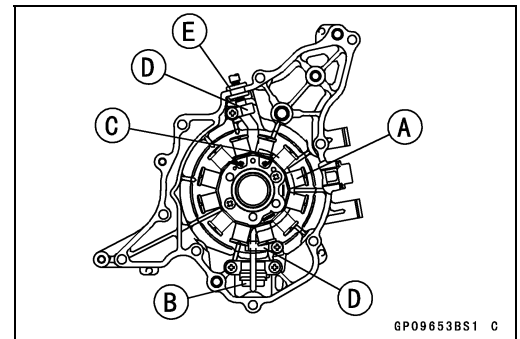

- Run the alternator lead [C] as shown, and then secure it with the clamps [D].
- Tighten:

**Torque - Alternator Lead Clamp Screws: 5.2 N·m (0.53 kgf·m, 46 in·lb)**

- Using a high flash-point solvent, clean off any oil or dirt that may be on the liquid gasket coating area. Dry them with a clean cloth.
- Apply liquid gasket to the circumference of the wiring grommet [E], and fit the grommet into the notch of the alternator cover securely.

**Sealant - Liquid Gasket, TB1211F: 92104-0004**

# 15-32 ELECTRICAL SYSTEM

## Charging System

### Alternator Rotor Removal

- Hold the alternator rotor with the flywheel holder as follows.

**Special Tool - Flywheel Holder: 57001-1313**

- Prepare the following rubber plate [A].  
Length: 300 mm (11.8 in.) [B]  
Width: 20 mm (0.79 in.) [C]  
Thickness: 3 mm (0.12 in.) or more [D]

- Put the rubber plate [A] between the band [B] of flywheel holder and the alternator rotor.
- Hold the stopper [C] of flywheel holder at a position [D] without the projections [E] of alternator rotor.
- Remove:
  - Alternator Rotor Nut [F]
  - Alternator Rotor [G]

- Thread the flywheel puller [A] and the rotor puller [B] onto the rotor [C].
- Holding the flywheel puller, turn the rotor puller until the flywheel is forced off the end of the crankshaft.

**Special Tools - Rotor Puller M18 × 1.5, M16 × 1.5: 57001-1099**  
**Flywheel Puller, M28 × 1.0: 57001-1471**

### NOTICE

**Do not attempt to strike the grab bar or the alternator rotor itself. Striking the bar or the rotor can cause the bar to bend or the magnets to lose their magnetism.**

### Alternator Rotor Installation

- Assemble the starter motor clutch to the alternator rotor (see Starter Motor Clutch Removal/Installation in the Crankshaft/Transmission chapter).
- Apply molybdenum disulfide oil solution to the crankshaft [A].
- Install the starter motor clutch gear [B] to the crankshaft.
- Using high flash-point solvent, clean off the any oil or dirt that may be on the crankshaft tapered portion [C] and the rotor tapered portion [D].
- Fit the woodruff key [E] securely in the slot [F] of the crankshaft before installing the rotor on the crankshaft.

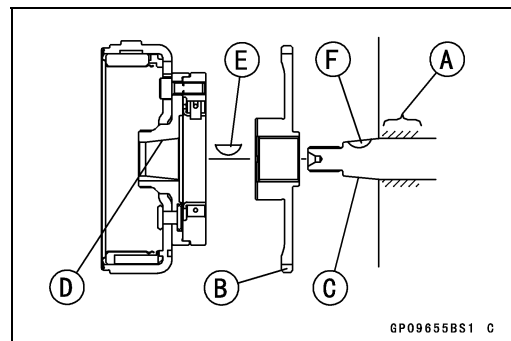
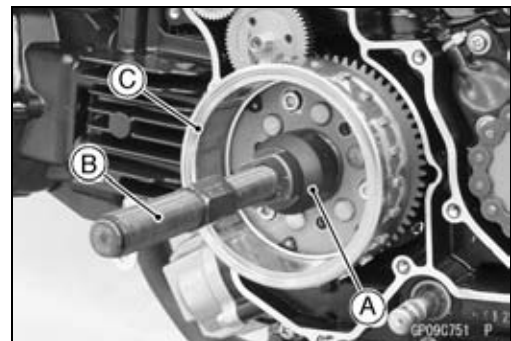
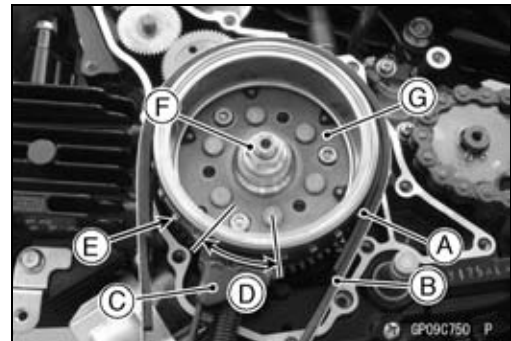
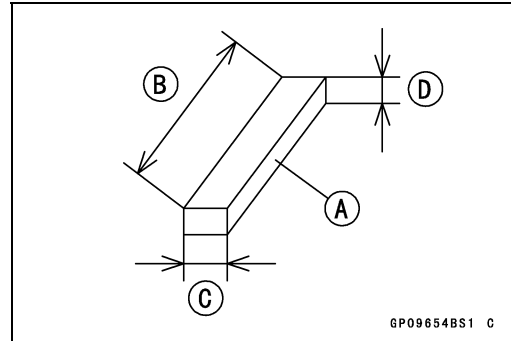



## Charging System

- Check that the starter motor clutch rollers are in place.
- Remove the starter idle gear and turn the torque limiter gear [A] counterclockwise.
- While fitting the alternator rotor [B] onto the crankshaft, rotate the starter motor clutch gear [C] clockwise.
- Install the starter idle gear.

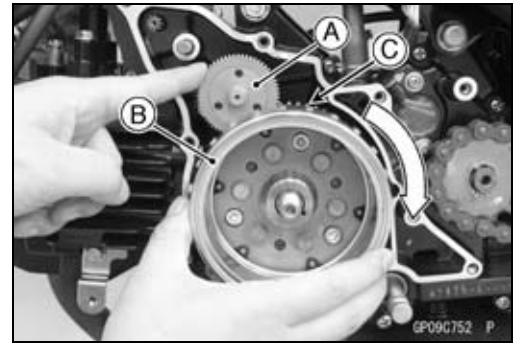

- Tighten the rotor nut [A] while holding the rotor [B] steadily with the flywheel holder [C] and rubber plate [D] (see Alternator Removal).

**Special Tool - Flywheel Holder: 57001-1313**

**Torque - Alternator Rotor Nut: 53.9 N·m (5.50 kgf·m, 39.8 ft·lb)**

- Install the alternator cover (see Alternator Cover Installation).

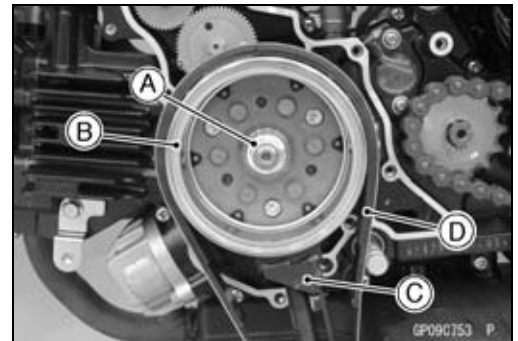

### Charging Voltage Inspection

- Check the battery condition (see Charging Condition Inspection).
- Warm up the engine to obtain actual alternator operating conditions.
- Check that the ignition switch is turned off, and connect a tester [A] to the battery terminals [B].
- Start the engine, and note the voltage readings at various engine speeds (except idling engine speed) with the headlight turned on and then turned off (To turn off the headlight, disconnect the headlight connector on the headlight unit.). The readings should show nearly battery voltage when the engine speed is low, and, as the engine speed rises, the readings should also rise. But they must be kept under the specified voltage.

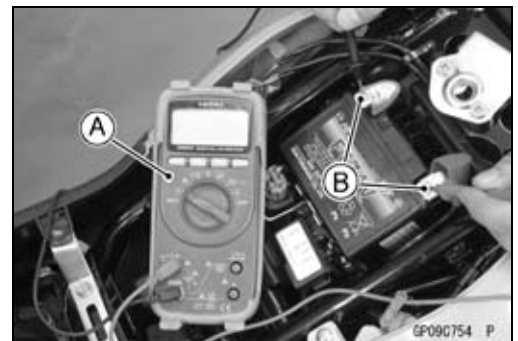

### Charging Voltage

Connections		Reading
Tester (+) to	Tester (-) to	
Battery (+)	Battery (-)	DC 14.2 ~ 14.8 V

- Turn off the ignition switch to stop the engine, and disconnect the tester.
- ★ If the charging voltage is kept between the values given in the table, the charging system is considered to be working normally.
- ★ If the charging voltage is much higher than the values specified in the table, the regulator/rectifier is defective or the regulator/rectifier leads are loose or open.
- ★ If the charging voltage does not rise as the engine speed increases, then the regulator/rectifier is defective or the alternator output is insufficient for the loads. Check the alternator and regulator/rectifier to determine which part is defective.

# 15-34 ELECTRICAL SYSTEM

## Charging System

### Alternator Inspection

There are three types of alternator failures: short, open (wire burned out), or loss in rotor magnetism. A short or open in one of the coil wires will result in either a low output, or no output at all. A loss in rotor magnetism, which may be caused by dropping or hitting the alternator, by leaving it near an electromagnetic field, or just by aging, will result in low output.

- To check the alternator output voltage, do the following procedures.
  - Turn the ignition switch off.
  - Disconnect the alternator lead connector [A].
  - Connect a tester as shown in the table 1.
  - Start the engine.
  - Run it at the rpm given in the table 1.
  - Note the voltage readings.



**Table 1 Alternator Output Voltage @4 000 r/min (rpm)**

Connections		Reading
Tester (+) to	Tester (-) to	
Yellow lead	Yellow lead	AC 70 V or more

- ★ If the output voltage shows the value in the table, the alternator operates properly.
- ★ If the output voltage shows a much lower reading than that given in the table, stop the engine and inspect the stator coil resistance.
  - Check the stator coil resistance as follows.
    - Stop the engine.
    - Connect the tester as shown in the table 2.
    - Note the readings.

**Table 2 Stator Coil Resistance @20°C (68°F)**

Connections		Reading
Tester (+) to	Tester (-) to	
Yellow lead	Yellow lead	0.2 ~ 0.7 Ω

When measuring the resistance, use a tester can that measure the standard value.

- ★ If there is more resistance than shown in the table, or no tester reading (infinity), the stator has an open lead and must be replaced. Much less than this resistance means the stator is shorted, and must be replaced.
- Measure the resistance between each lead and chassis ground.
- ★ Any tester reading less than infinity ( $\infty$ ) indicates a short, necessitating stator replacement.
- ★ If the stator coils have normal resistance, but the voltage check showed the alternator to be defective; then the rotor magnets have probably weakened, and the rotor must be replaced.

## Charging System

### Regulator/Rectifier Removal

- Remove:
  - Canister Bracket (see Canister Removal in the Periodic Maintenance chapter)
- Slide the dust covers [A] and disconnect the regulator/rectifier connectors [B].

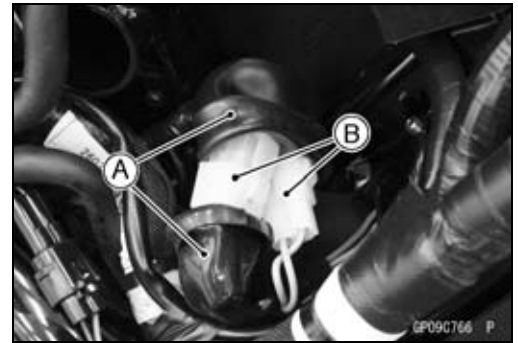

- Remove:
  - Regulator/Rectifier Mounting Bolts [A]
  - Regulator/Rectifier [B]
  - Plate

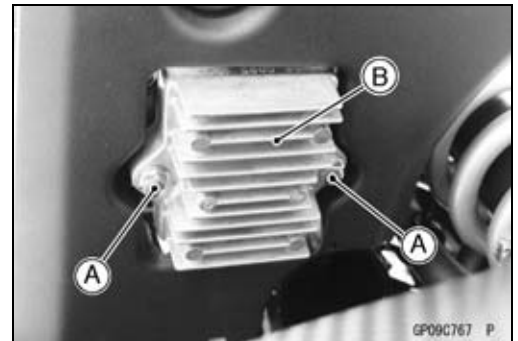

### Regulator/Rectifier Installation

- Installation is the reverse of removal.
- Run the regulator/rectifier lead correctly (see Cable, Wire, and Hose Routing section in the Appendix chapter).
- Apply a non-permanent locking agent to the threads of the regulator/rectifier mounting bolts.
- Tighten:
  - Torque - Regulator/Rectifier Mounting Bolts: 9.8 N·m (1.0 kgf·m, 87 in·lb)**

### Regulator/Rectifier Inspection

- Refer to the Charging System Troubleshooting for the Regulator/Rectifier Inspection.

### Charging System Troubleshooting

- Before inspection, remove all accessories that consume electrical power.

#### NOTE

○ *Even when the charging system is working properly, the battery may discharge if the motorcycle is equipped with too many accessories.*

- Pay attention to riding conditions and the customer's riding habits which could affect the charging system such as:

Frequent use at low engine speed  
 Frequent and unnecessary brake pedal dragging → Battery Discharged

- Recharge the battery if it is discharged.

# 15-36 ELECTRICAL SYSTEM

## Charging System

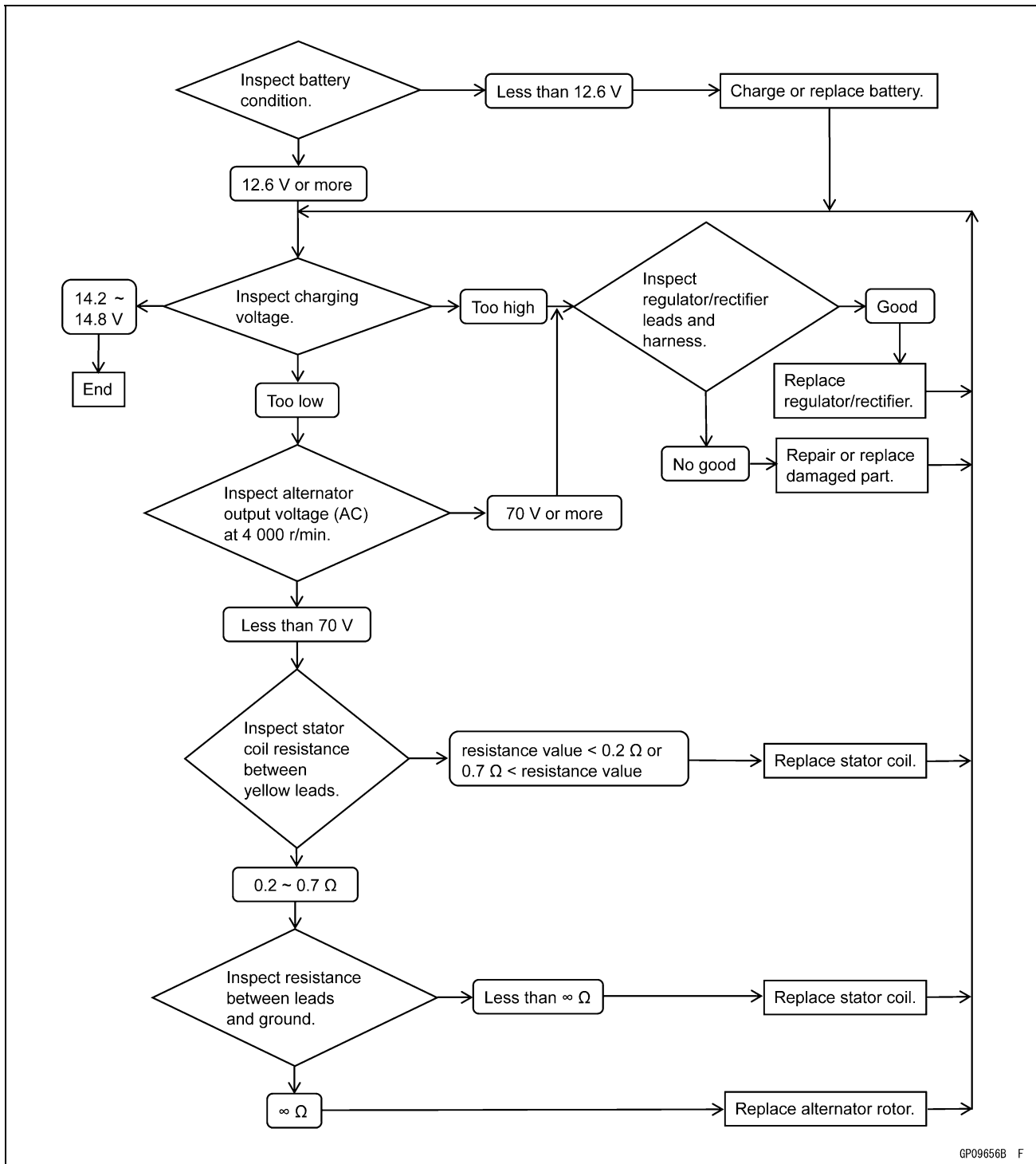

Charging System

Charging System Circuit

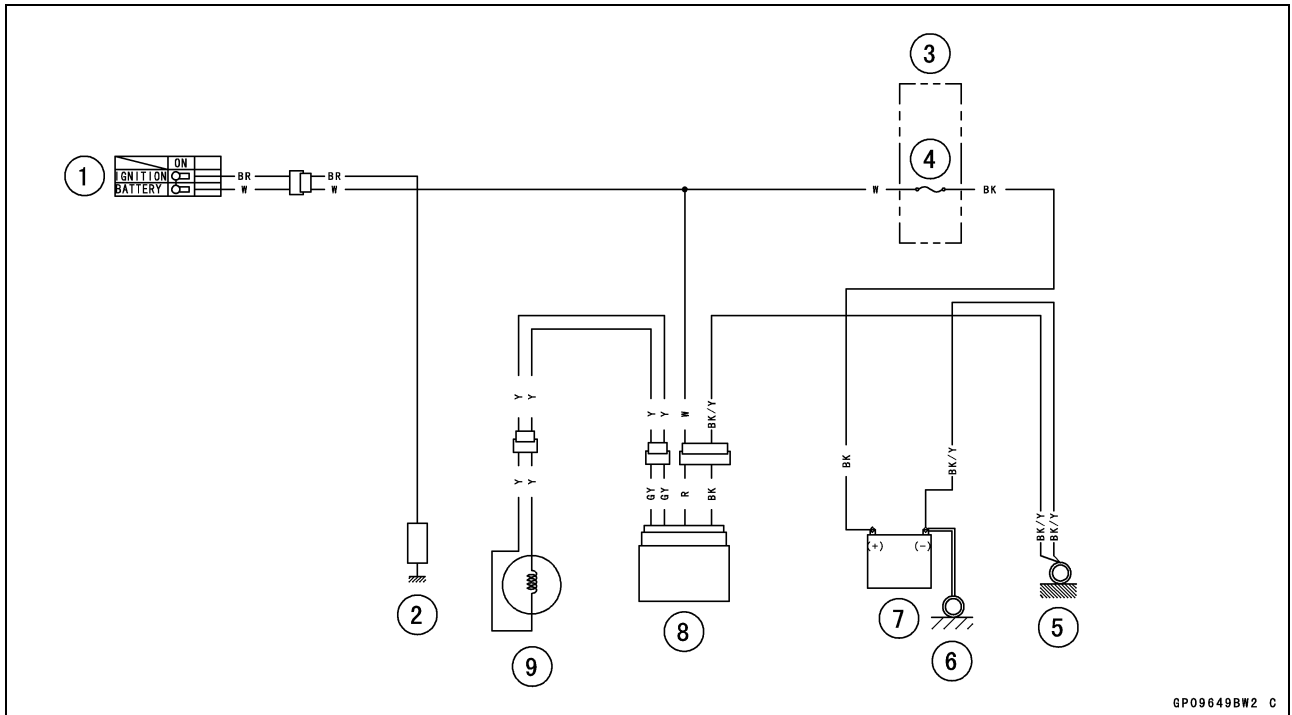

GP09649BW2 C

1. Ignition Switch
2. Load
3. Fuse Box
4. Battery Fuse 20 A
5. Frame Ground
6. Engine Ground
7. Battery 12 V 3 Ah
8. Regulator/Rectifier
9. Alternator

## 15-38 ELECTRICAL SYSTEM

### Ignition System

#### **⚠ WARNING**

The ignition system produces extremely high voltage. Do not touch the spark plug, ignition coil or high-tension lead while the engine is running, or you could receive a severe electrical shock.

#### **NOTICE**

Do not disconnect the battery cables or any other electrical connections when the ignition switch is on, or while the engine is running. This is to prevent IC igniter damage.

Do not install the battery backwards. The negative side is grounded. This is to prevent damage to the diodes and the IC igniter.

#### ***Crankshaft Sensor Removal***

- Refer to the Stator Coil Removal.

#### ***Crankshaft Sensor Installation***

- Refer to the Stator Coil Installation.

#### ***Crankshaft Sensor Inspection***

- Disconnect the crankshaft sensor lead connector (see Alternator Cover Removal).
- Set a tester [A], and connect it to the crankshaft sensor lead connector [B].

#### **Crankshaft Sensor Resistance**

##### **Connections:**

Tester (+) → BL/Y lead

Tester (-) → G lead

Standard: 100 ~ 140 Ω @20°C (68°F)

- ★ If there is more resistance than the specified value, the coil has an open lead and must be replaced. Much less than this resistance means the coil is shorted, and must be replaced.

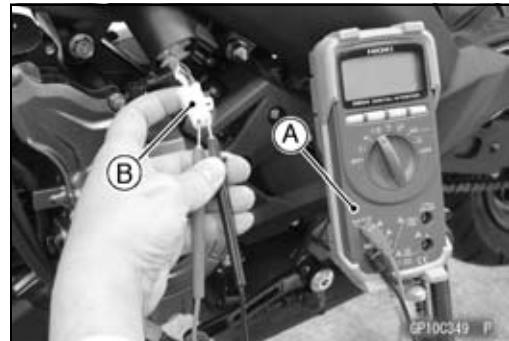

## Ignition System

### Crankshaft Sensor Peak Voltage Inspection

#### NOTE

- Be sure the battery is fully charged.
- Using the peak voltage adapter [A] is more reliable way to determine the condition of the crankshaft sensor than crankshaft sensor internal resistance measurements.

- Disconnect the crankshaft sensor lead connector [B] (see Alternator Cover Removal).
- Set a tester [C], and connect it to the peak voltage adapter.

**Special Tool - Peak Voltage Adapter: 57001-1415**

**Type: KEK-54-9-B**

- Connect the adapter to the terminal of the crankshaft sensor lead connector.

#### Connections:

Crankshaft Sensor Lead		Peak Voltage Adapter		Tester
BL/Y lead	←	R lead	→	(+)
G lead	←	BK lead	→	(-)

- Turn the engine stop switch to run position.
- Turn the ignition switch on.
- Pushing the starter button with the transmission gear in neutral, turn the engine 4 ~ 5 seconds to measure the crankshaft sensor peak voltage.
- Repeat the measurement 5 or more times.

#### Crankshaft Sensor Peak Voltage

**Standard: 3.5 V or more**

- ★ If the reading is less than the standard, inspect the crankshaft sensor (see Crankshaft Sensor Inspection).

### Ignition Coil Removal

- Remove the right side/frame cover (see Side/Frame Cover Removal in the Frame chapter).
- Open the clamp [A].
- Disconnect the spark plug cap [B].

#### NOTICE

**When removing the spark plug cap, do not pull the lead. The lead could be break off or damage the wires inside.**

- Disconnect the ignition coil primary lead connectors [A].
- Remove:
  - Ignition Coil Mounting Bolts [B]
  - Ignition Coil [C]
  - Collar [D]

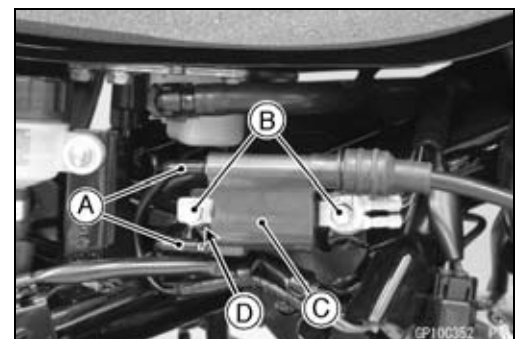
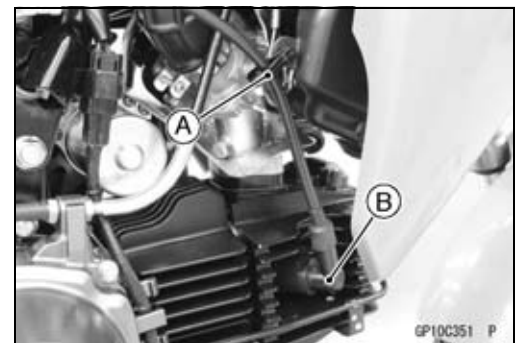
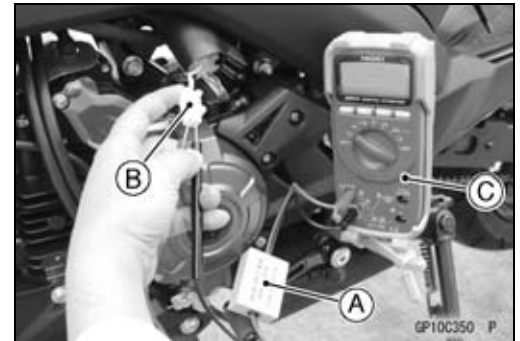

# 15-40 ELECTRICAL SYSTEM

## Ignition System

### Ignition Coil Installation

- Installation is the reverse of removal.
- Run the leads correctly (see Cable, Wire, and Hose Routing section in the Appendix chapter).
- Tighten:
  - Torque - Ignition Coil Mounting Bolts: 4.0 N·m (0.41 kgf·m, 35 in·lb)**
- Install the spark plug cap.
- Be sure the spark plug cap is installed securely by pulling up it lightly.
- Install the removed parts (see appropriate chapters).

### Ignition Coil Inspection

- Remove the ignition coil (see Ignition Coil Removal).
- Measure the primary winding resistance [A] as follows.
  - Connect a tester between the coil terminals.
- Measure the secondary winding resistance [B] as follows.
  - Remove the plug cap by turning it counterclockwise.
  - Connect the tester between the high-tension lead and ground terminal.

#### Ignition Coil Winding Resistance

**Primary Windings: 2.07 ~ 2.53  $\Omega$**

**Secondary Windings: 7.44 ~ 11.2 k $\Omega$**

- ★ If the tester does not read as specified, replace the coil [C].
- ★ If the tester reads as specified, the ignition coil windings are probably good. However, if the ignition system still does not perform as it should after all other components have been checked, test replace the coil with one known to be good.
- Check the high-tension lead for visible damage.
- ★ If the high-tension lead is damaged, replace the coil.

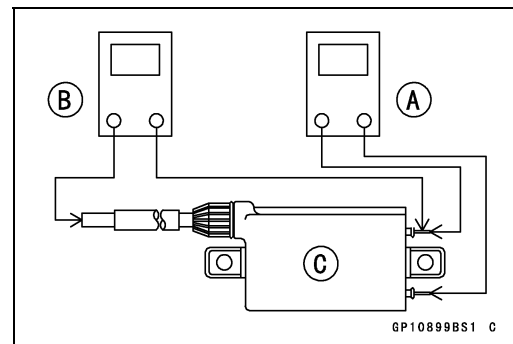



## Ignition System

### Ignition Coil Primary Peak Voltage Inspection

#### NOTE

○Be sure the battery is fully charged.

- Remove:
  - Right Side/Frame Cover (see Side/Frame Cover Removal in the Frame chapter)
- Remove the spark plug cap but do not remove the spark plug.
- Install a new spark plug [A] into the spark plug cap.
- Connect the peak voltage adapter [B] to the tester [C].

**Special Tool - Peak Voltage Adapter: 57001-1415**

**Type: KEK-54-9-B**

- Connect the peak voltage adapter to the ignition coil terminal.
  - ECU [D]
  - Battery [E]
  - Ignition Coil [F]

#### Connections:

		Peak Voltage Adapter		Tester
Terminal (R Lead) [G]	←	R Lead	→	(+)
Ground [H]	←	BK Lead	→	(-)

#### **⚠ WARNING**

**To avoid extremely high voltage shocks, do not touch the spark plug or tester connections.**

- Push the engine stop switch to run position.
- Turn the ignition switch on.
- Ground the new spark plug onto the engine.
- Pushing the starter button, turn the engine 4 ~ 5 seconds with the transmission in neutral to measure the primary peak voltage.
- Repeat the measurements 5 times.

#### Ignition Coil Primary Peak Voltage

**Standard: 155 V or more**

- ★ If the reading is less than the specified value, check the following:
  - Ignition Coil (see Ignition Coil Inspection)
  - Crankshaft Sensor (see Crankshaft Sensor Inspection)
- ★ If the ignition coil and crankshaft sensor are normal, check the ECU (see ECU Power Supply Inspection in the Fuel System (DFI) chapter).

#### Spark Plug Removal

- Refer to the Spark Plug Replacement in the Periodic Maintenance chapter.

#### Spark Plug Installation

- Refer to the Spark Plug Replacement in the Periodic Maintenance chapter.

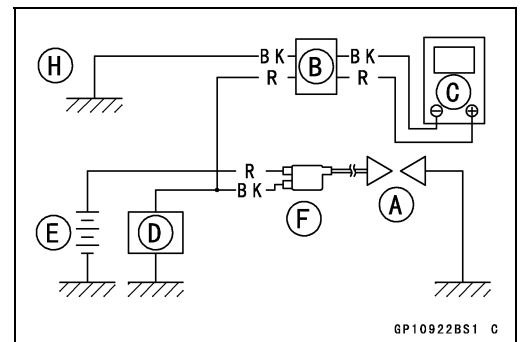
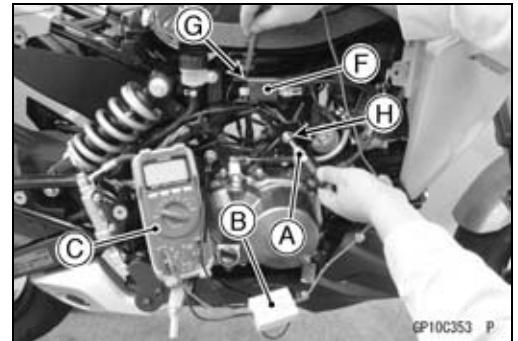

## 15-42 ELECTRICAL SYSTEM

### Ignition System

#### Spark Plug Condition Inspection

- Clean the spark plug, preferably in a sandblasting device, and then clean off any abrasive particles. The plug may also be cleaned using high flash-point solvent and a wire brush or other tool.
- ★ If the spark plug center electrode [A] and/or side electrode [B] are corrected or damaged, or if the insulator [C] is cracked, replace the plug.
- Use the standard spark plug or its equivalent.
- Measure the gap [D] with a wire-type thickness gauge.

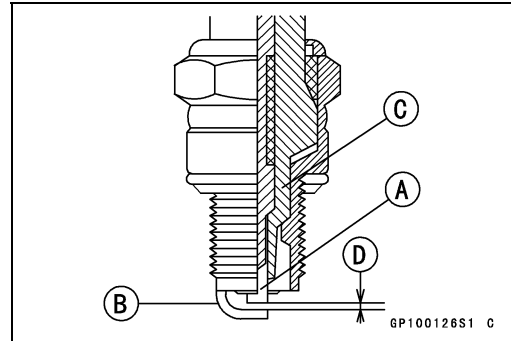

#### Spark Plug Gap

Standard: 0.6 ~ 0.7 mm (0.024 ~ 0.028 in.)

- ★ If the gap is incorrect, carefully bend the side electrode with a suitable tool to obtain the correct gap.

#### Interlock Operation Inspection (BR125H/J)

- Raise the rear wheel off the ground with the stand.
- Turn the engine stop switch on (run position).
- Start the engine to the following conditions.

#### Condition:

Transmission Gear → 1st Position

Clutch Lever → Release

- Turn the ignition switch on and push the starter button.
- Then the starter motor should not turn when the starter system circuit is normality.
- ★ If the engine is started, inspect the starter lockout switch, gear position switch and diode.

#### Diode Inspection

- Remove:
  - Left Middle Fairing (see Middle Fairing Removal in the Frame chapter)
  - Diode (1) [A]
- Remove (BR125H):
  - Left Side/Frame Cover (see Side/Frame Cover Removal in the Frame chapter)
  - Diode (2) [A]

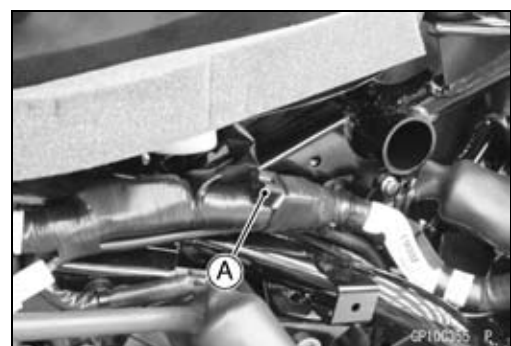

## Ignition System

- Remove (BR125J):  
Seat (see Seat Removal in the Frame chapter)  
Diode (2) [A]



- Set a tester, and check conductivity of the terminals in the diode.  
Anode  
Cathode
- ★ The resistance should be low in one direction and more than ten times as much in the other direction. If the diode shows low or high in both directions, the diode is defective and the diode must be replaced.

### NOTE

- The actual meter reading varies with the meter or tester used and the individual diode, but generally speaking, the lower reading should be from zero to one half the scale.

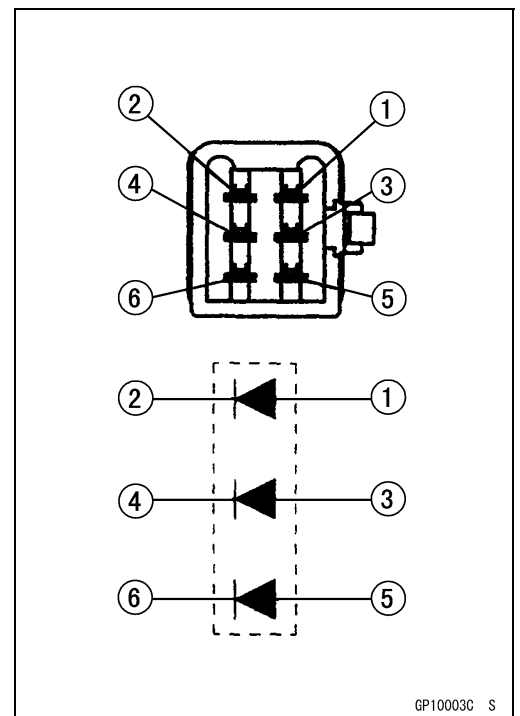
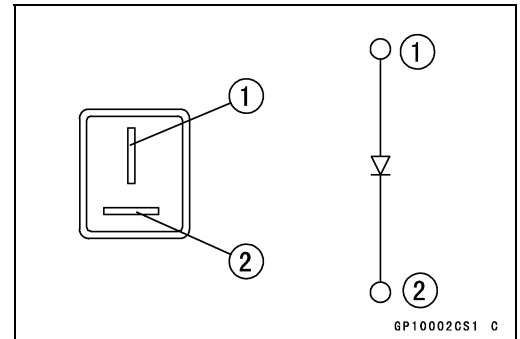

# 15-44 ELECTRICAL SYSTEM

## Ignition System

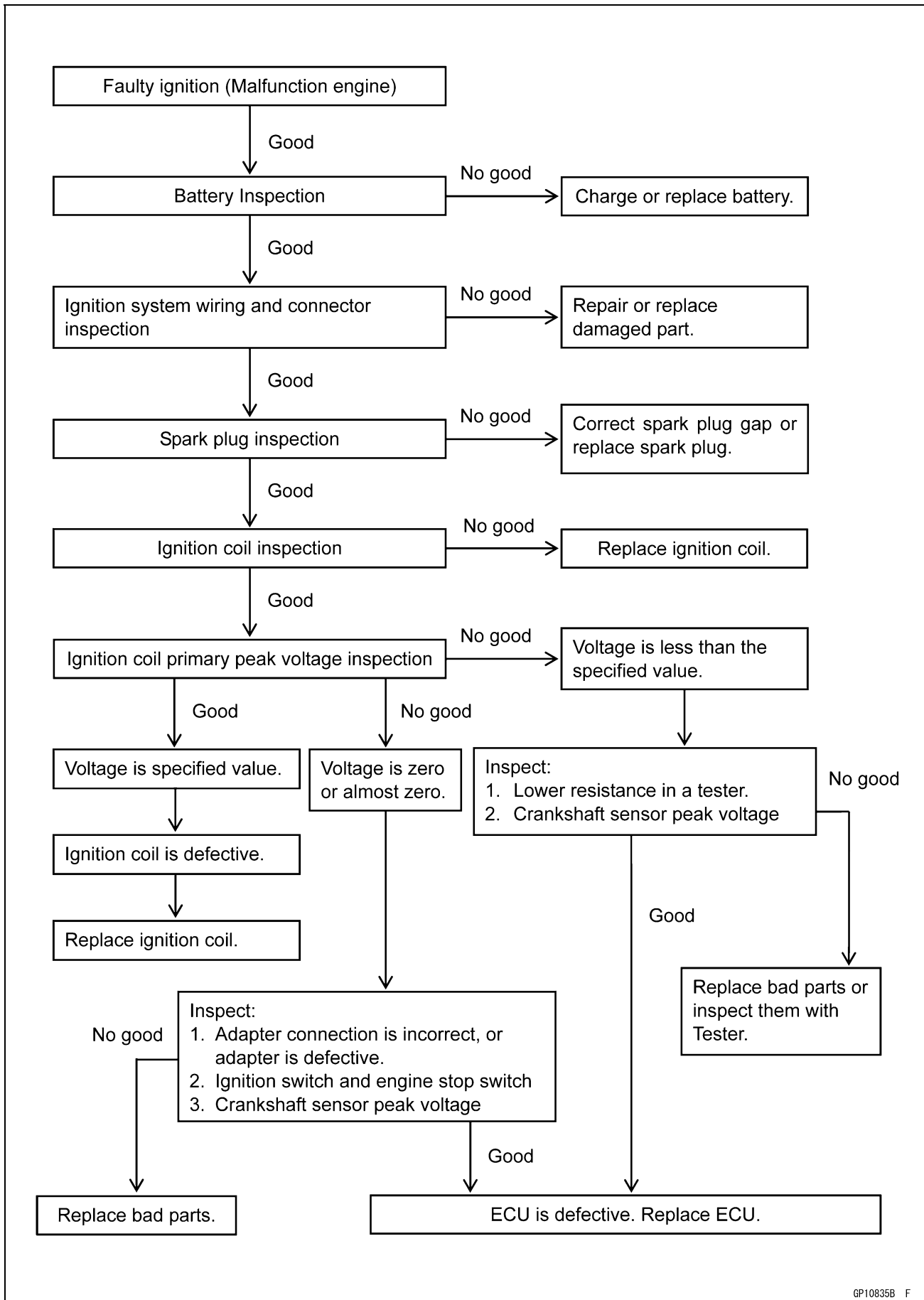

Ignition System

Ignition System Circuit (BR125G/H)

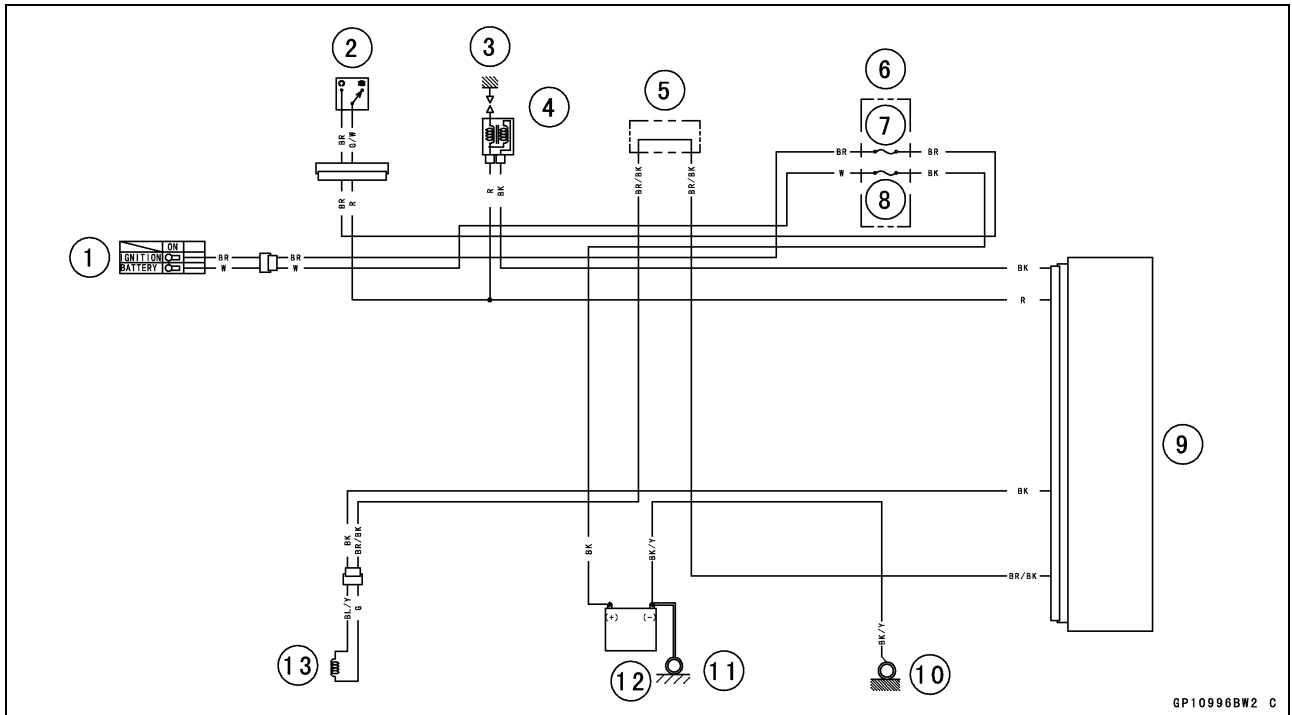

GP10996BW2 C

- |                       |                       |
|-----------------------|-----------------------|
| 1. Ignition Switch    | 8. Battery Fuse 20 A  |
| 2. Engine Stop Switch | 9. ECU                |
| 3. Spark Plug         | 10. Frame Ground      |
| 4. Ignition Coil      | 11. Engine Ground     |
| 5. Water-proof Joint  | 12. Battery 12 V 3 Ah |
| 6. Fuse Box           | 13. Crankshaft Sensor |
| 7. Ignition Fuse 10 A |                       |

# 15-46 ELECTRICAL SYSTEM

## Ignition System

### Ignition System Circuit (BR125J)

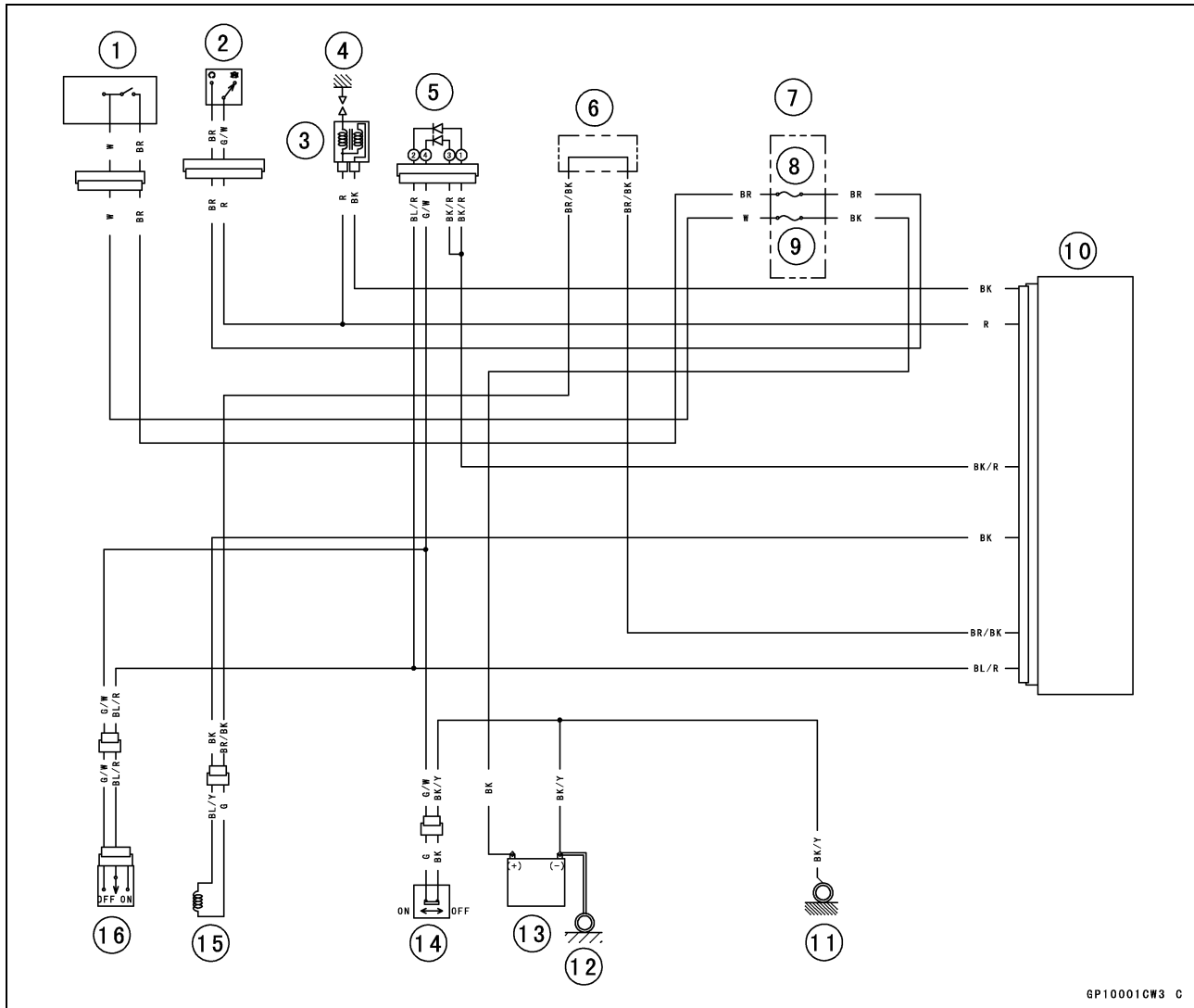

6P10001CW3 C

- |                       |                            |
|-----------------------|----------------------------|
| 1. Ignition Switch    | 9. Battery Fuse 20 A       |
| 2. Engine Stop Switch | 10. ECU                    |
| 3. Ignition Coil      | 11. Frame Ground           |
| 4. Spark Plug         | 12. Engine Ground          |
| 5. Diode (2)          | 13. Battery 12 V 3 Ah      |
| 6. Water-proof Joint  | 14. Side Stand Switch      |
| 7. Fuse Box           | 15. Crankshaft Sensor      |
| 8. Ignition Fuse 10 A | 16. Starter lockout Switch |

## Electric Starter System

### Starter Motor Removal

- Remove the left side/frame cover (see Side/Frame Cover Removal in the Frame chapter).
- Disconnect:
  - Clutch Cable Lower End (see Clutch Cable Removal in the Clutch chapter) (BR125H/J)
  - Starter Motor Lead Connector [A]

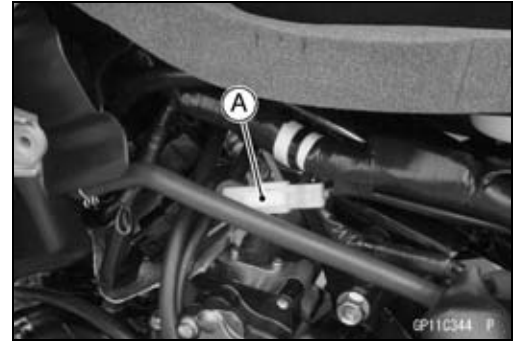

- Bend the clamp [A] straighten.

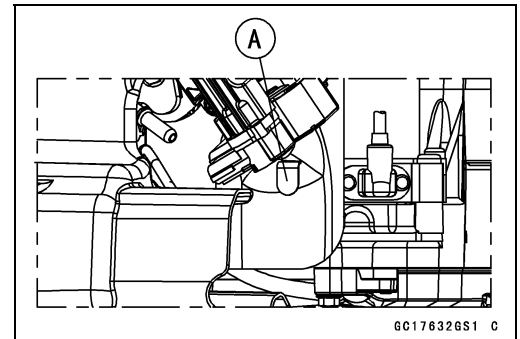

- Remove:
  - Starter Motor Mounting Screws [A]
  - Clamp [B]
- Take off the starter motor [C] gently.

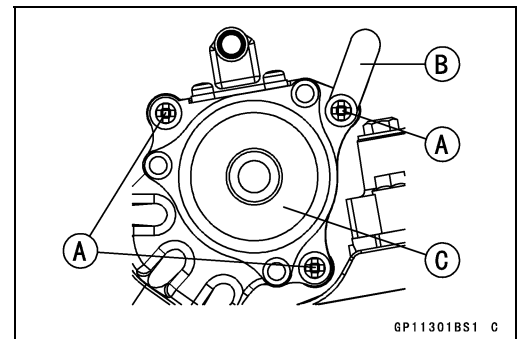

### Starter Motor Installation

- Installation is the reverse of removal.
- Clean the starter motor legs and crankcase where the starter motor is ground.
- Replace the O-ring [A] with a new one.
- Apply grease to the new O-ring.

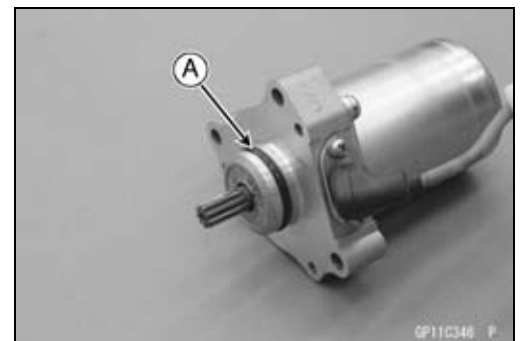

- Insert the clamp [A] to the slit of the heat insulation guard [B].
- Bend the clamp.
  - About 22 mm (0.87 in.) [C]

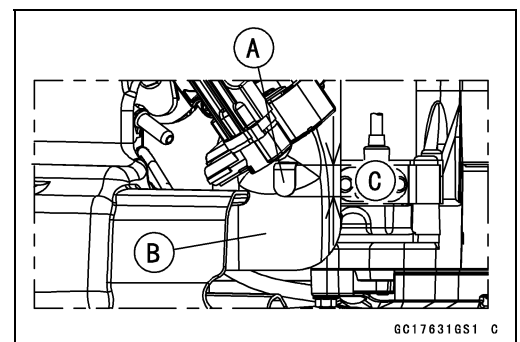

# 15-48 ELECTRICAL SYSTEM

## Electric Starter System

- Install the starter motor [A] and clamp [B] as shown.  
About 20° [C]
- Tighten:  
**Torque - Starter Motor Mounting Screws [D]: 5.2 N·m (0.53 kgf·m, 46 in·lb)**
- Connect:  
Clutch Cable Lower End (see Clutch Cable Installation in the Clutch chapter) (BR125H/J)  
Starter Motor Lead Connector

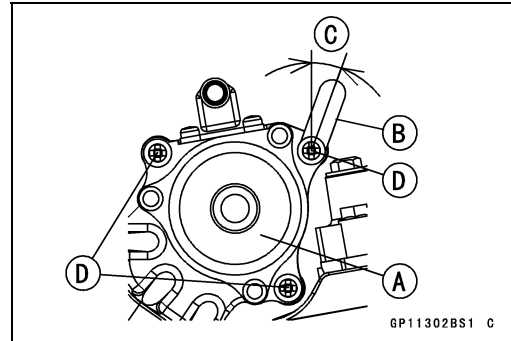

### Starter Motor Disassembly

- Remove the starter motor (see Starter Motor Removal).
- Remove the starter motor terminal screw [A].



- Remove the end cover screws [A].
- Hold the pinion gear portion [B] and pull out the yoke [C].

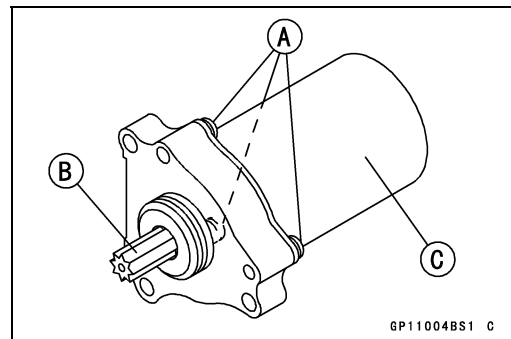

- Remove the armature [A] and gasket [B] from the end cover [C].

### NOTE

○ Wrap the pinion gear portion [D] by the vinyl tape before removal of the armature.

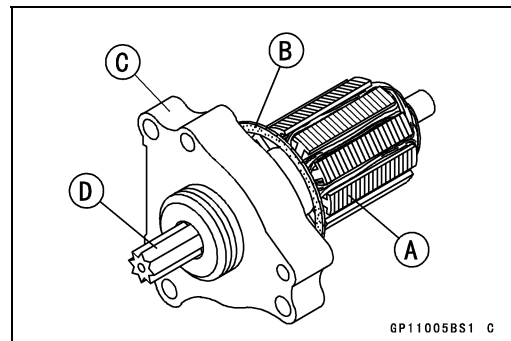

- Pull out the carbon brush springs [A].
- Remove the brush holder plate screws [B] and flat washers.
- Remove the negative (-) carbon brush [C].

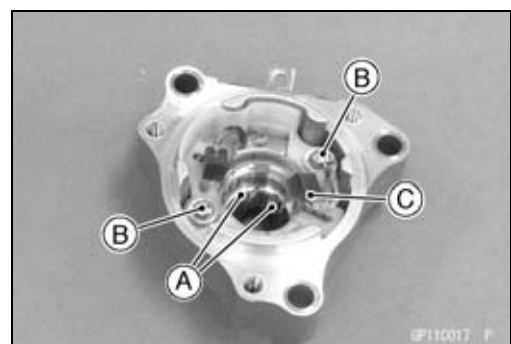



## Electric Starter System

- Remove the terminal cover plate screws [A] and terminal cover plate [B].
- Push the terminal [C] into the end cover.
- Remove the terminal with positive (+) carbon brush.
- Remove the brush holder plate [D] and insulator plates.
- ★ If necessary, remove the oil seal [E] from the end cover using a suitable tool (or oil seal remover).

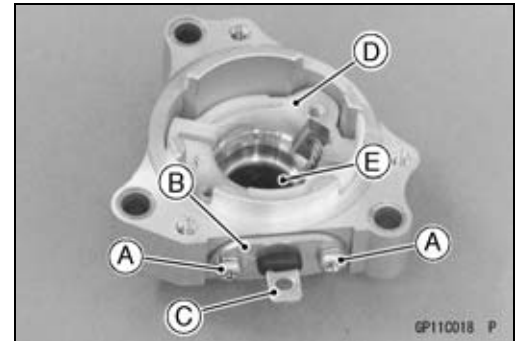

- Using a suitable tool [A] (or a bearing puller), remove the bearing [B] from the armature shaft.

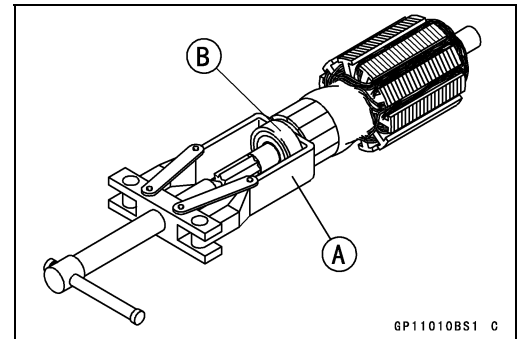

### Starter Motor Assembly

- Smooth the commutator surface if necessary with fine emery paper (more than #600).
- Blow or wipe the parts of the starter motor to clean the dust or any carbon particles.
- If the oil seal has been removed, press the new oil seal [A] into the end cover as shown using a suitable tool [B].  
22.6 ~ 23 mm (0.89 ~ 0.91 in.) [B]

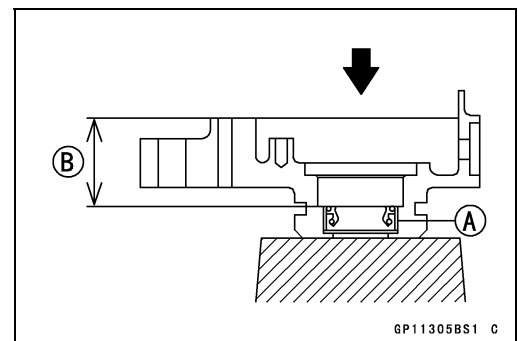

- Replace the bearing with a new one.
- Press in the bearing [A] with a suitable tool [B] as shown.  
97.37 ~ 97.53 mm (3.833 ~ 3.840 in.) [C]

### NOTE

- Install the bearing with the marked side toward the pinion gear.
- Spin the bearing by hand to check its condition. If it is noisy or does not spin smoothly, replace it.

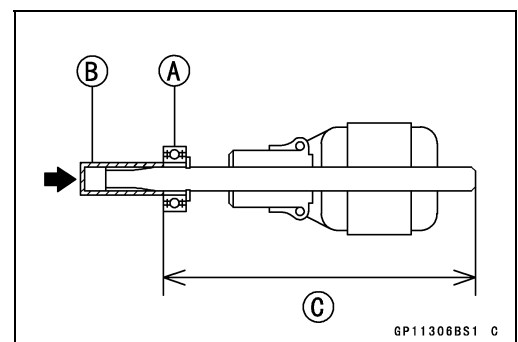

- Install the insulator plates [A] and brush holder plate [B].
- Install the brush holder plate so that its slot [C] aligns with the hole [D] on the end cover.

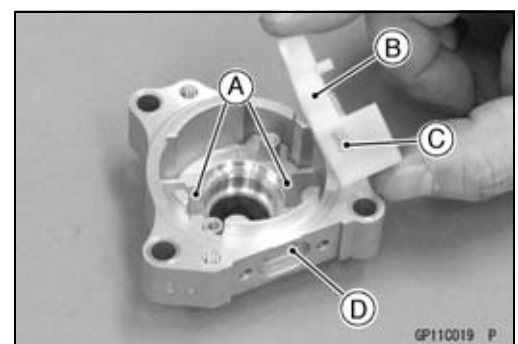

# 15-50 ELECTRICAL SYSTEM

## Electric Starter System

- Apply adhesive [A] to the terminal [B] as shown.

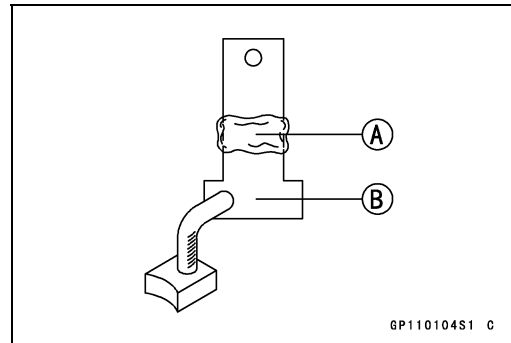

- Insert the terminal [A] into the grommet [B] from inside.
- Install the negative (-) carbon brush.
- Tighten the brush holder plate screws [C] and flat washers.

**Torque - Starter Motor Brush Holder Plate Screws: 0.89 N·m (0.091 kgf·m, 7.9 in·lb)**

- Install the terminal cover plate [D] so that the flat side faces outside and tighten the screws [E].

**Torque - Starter Motor Terminal Plate Screws: 2.0 N·m (0.20 kgf·m, 18 in·lb)**

- Insert the brush springs [F] into the brush holders.
- Insert the brushes [A] into the brush holder until it is bottomed.
- Hold the brushes in the brush holder using the suitable holding tools [B] to hold the brush leads as shown.
- Apply grease to the oil seal lips.

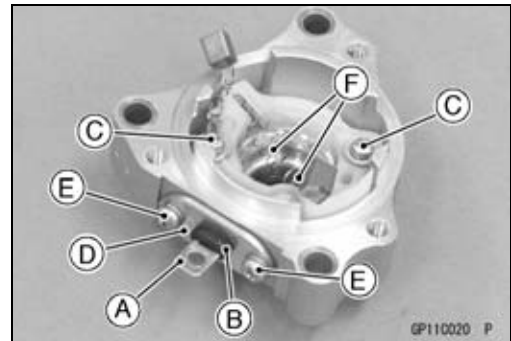

- Wrap the pinion gear portion with the vinyl tape to prevent the oil seal from damaging during installation.
- Insert the armature [A] into the end cover [B].
- Remove the holding tools [C].

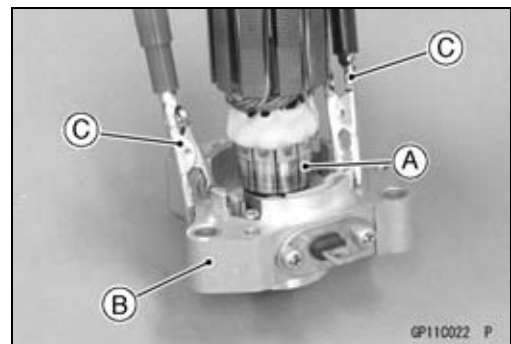
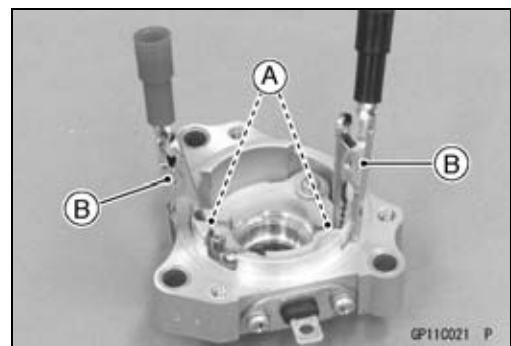

## Electric Starter System

- Check that movement of the brushes [A] and they contact with the commutator [B] properly.
- Raise the lead.
- Apply grease to the shaft end of the armature.
- Replace the gasket with a new one.
- Install the gasket [C] and yoke to the end cover.
- Tighten:

**Torque - Starter Motor End Cover Screws: 4.4 N·m (0.45 kgf·m, 39 in·lb)**

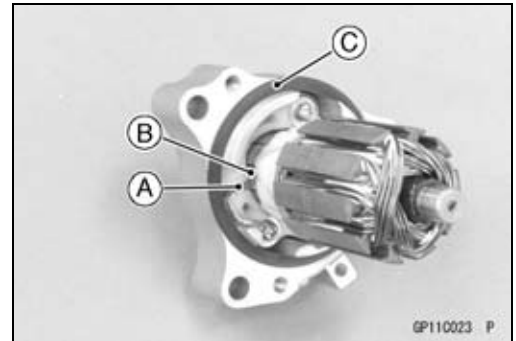

### Brush Inspection

- Measure the overall length of each brush [A].

#### Starter Motor Brush Length

**Standard: 7 mm (0.28 in.)**

**Service Limit: 3.5 mm (0.14 in.)**

- ★ If any is worn down to the service limit, replace the carbon brush.

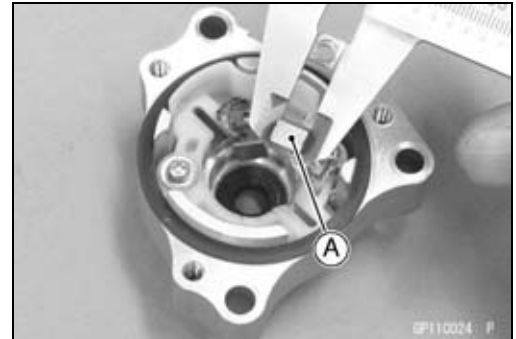

### Commutator Cleaning and Inspection

- A dirty or damaged commutator will result in poor brush contact and cause the brushes to wear down quickly. In addition, particles from brush wear accumulating between commutator segments may cause partial shorts.
- Smooth the commutator surface [A] if necessary with fine emery paper [B] and clean out the grooves.

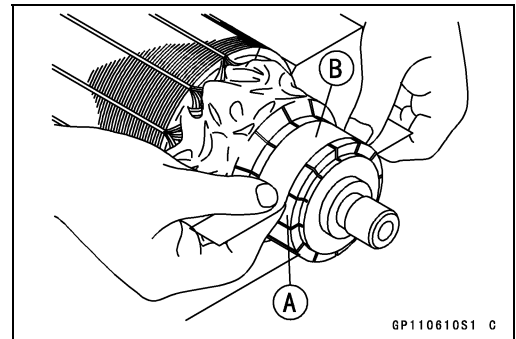

- Measure the diameter [A] of the commutator [B].

#### Commutator Diameter

**Standard: 22 mm (0.87 in.)**

**Service Limit: 21.5 mm (0.846 in.)**

- ★ Replace the starter motor with a new one if the commutator diameter is less than the service limit.

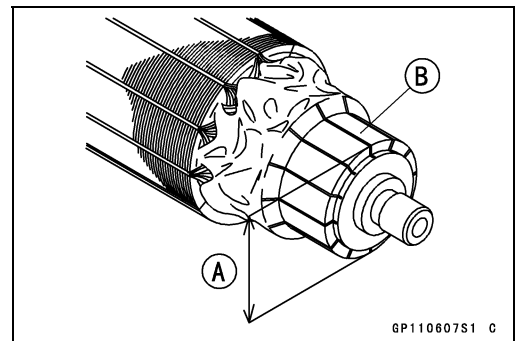

## 15-52 ELECTRICAL SYSTEM

### Electric Starter System

#### Armature Inspection

- Using a tester, measure the resistance between any two commutator segments [A].
- ★ If there is a high resistance or no reading ( $\infty$ ) between any two segments, a winding is open and the starter motor must be replaced.
- Measure the resistance between the segments and the shaft [B].
- ★ If there is any reading at all, the armature has a short and the starter motor must be replaced.

#### NOTE

○ Even if the foregoing checks show the armature to be good, it may be defective in some manner not readily detectable with the hand tester. If all other starter motor and starter motor circuit components check good, but the starter motor still does not turn over or only turns over weakly, replace the starter motor with a new one.

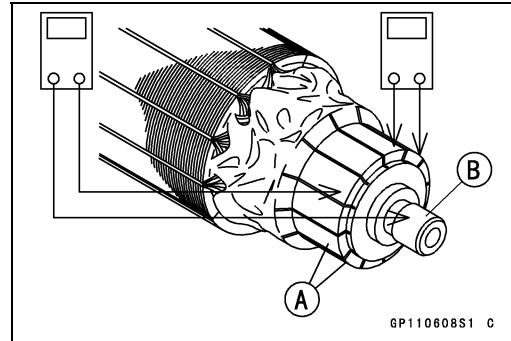

#### Brush Lead Inspection

- Using a tester, measure the resistance as shown.
  - Terminal and Positive (+) Brush [A]
  - Right-hand End Cover and Negative (-) Brushes [B]
- ★ If there is not close to zero ohms, the brush lead has an open. Replace the brush plate assy.

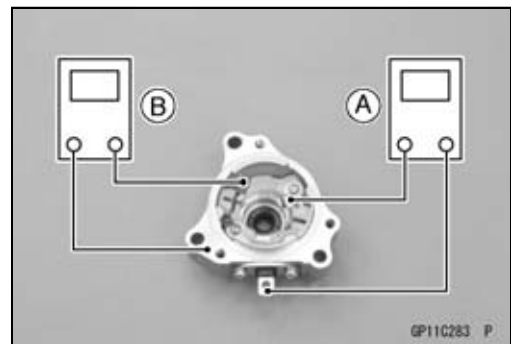

#### Right-hand End Cover Inspection

- Using the highest tester range, measure the resistance as shown.
  - Terminal and Right-hand End Cover [A]
  - Terminal and Negative (-) Brush [B]
- ★ If there is any reading, the brush assy and/or terminal have a short. Replace the brush plate assy.

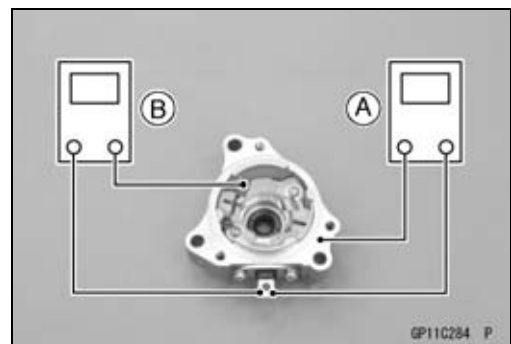

#### Starter Relay Inspection

- Remove the seat (see Seat Removal in the Frame chapter).
- Remove the starter relay dust cover [A] from the bracket [B].

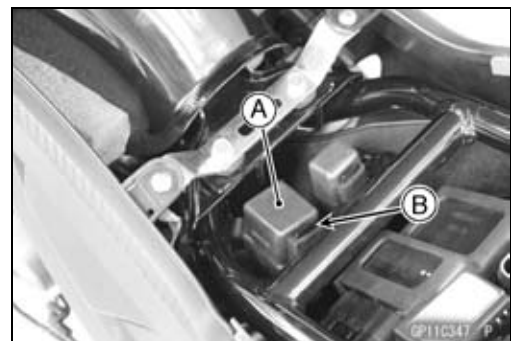

**Electric Starter System**

- Disconnect the starter relay connector [A].
- Remove the starter relay [B].

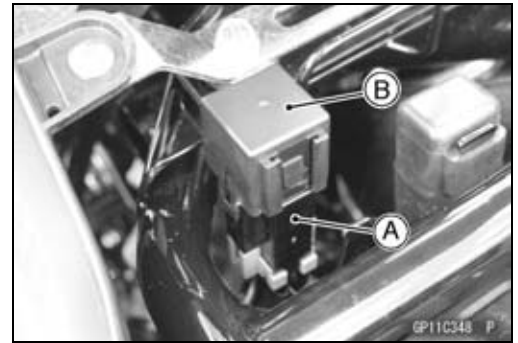

- Connect a tester [A] and 12 V battery [B] to the starter relay [C] as shown.
- ★ If the relay does not work as specified, the relay is defective. Replace the relay.

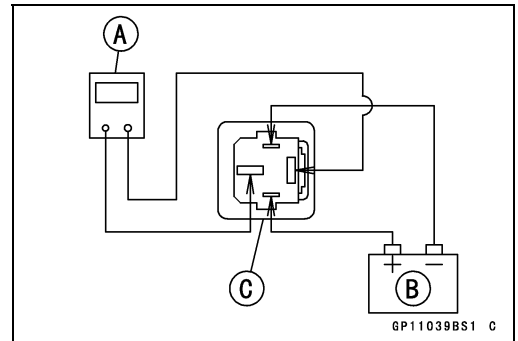

**Testing Relay**

**Criteria:** When battery is connected → 0 Ω

When battery is disconnected → ∞ Ω

**Electric Starter Circuit (BR125G)**

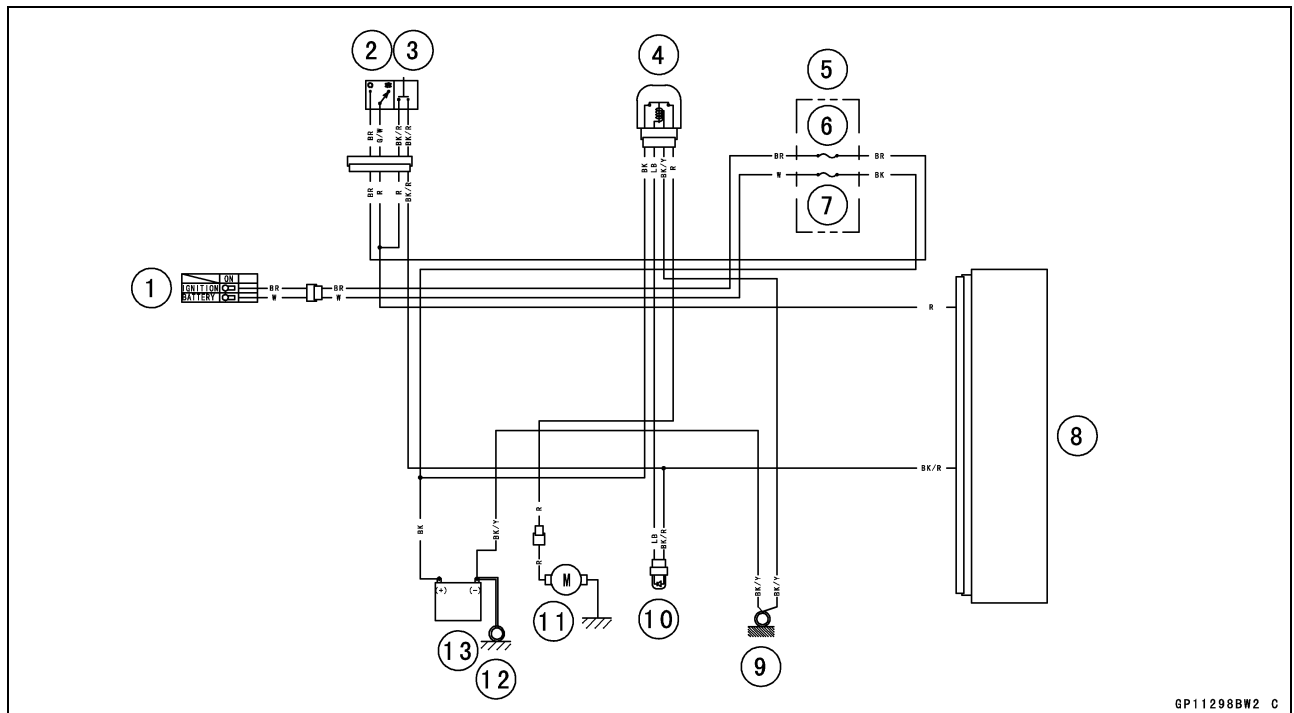

1. Ignition Switch
2. Engine Stop Switch
3. Starter Button
4. Starter Relay
5. Fuse Box
6. Ignition Fuse 10 A
7. Battery Fuse 20 A
8. ECU
9. Frame Ground
10. Diode (1)
11. Starter Motor
12. Engine Ground
13. Battery 12 V 3 Ah

# 15-54 ELECTRICAL SYSTEM

## Electric Starter System

### Electric Starter Circuit (BR125H)

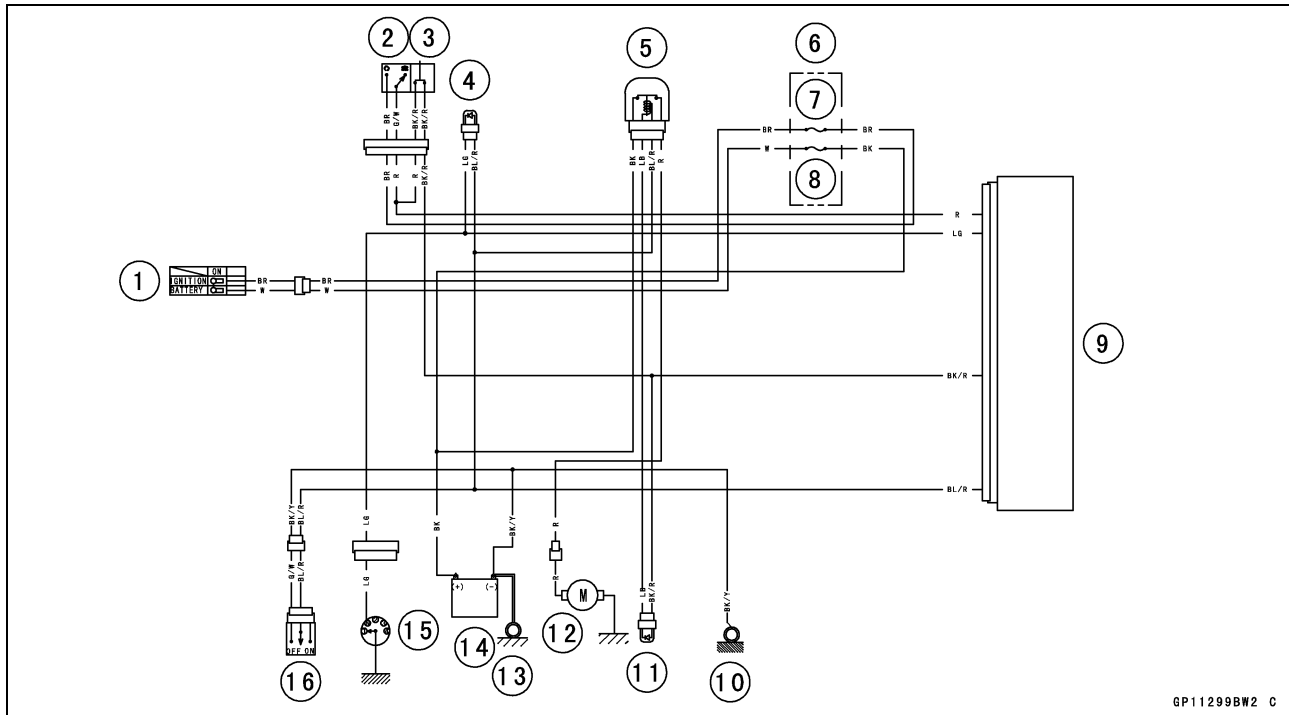

GP11299BW2 C

1. Ignition Switch
2. Engine Stop Switch
3. Starter Button
4. Diode (2)
5. Starter Relay
6. Fuse Box
7. Ignition Fuse 10 A
8. Battery Fuse 20 A
9. ECU
10. Frame Ground
11. Diode (1)
12. Starter Motor
13. Engine Ground
14. Battery 12 V 3 Ah
15. Gear Position Switch
16. Starter Lockout Switch

Electric Starter System

Electric Starter Circuit (BR125J)

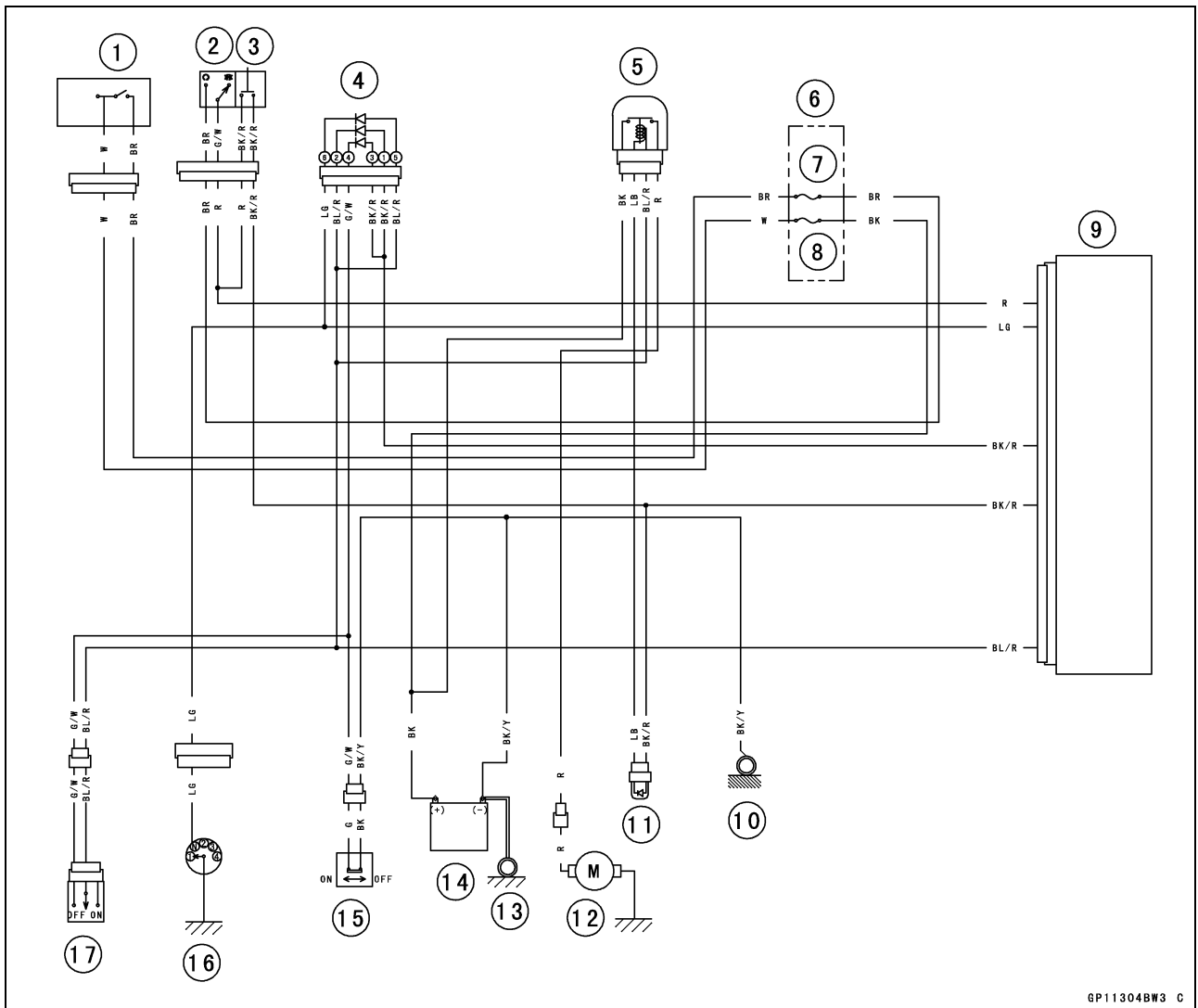

GP11304BW3 C

1. Ignition Switch
2. Engine Stop Switch
3. Starter Button
4. Diode (2)
5. Starter Relay
6. Fuse Box
7. Ignition Fuse 10 A
8. Battery Fuse 20 A
9. ECU
10. Frame Ground
11. Diode (1)
12. Starter Motor
13. Engine Ground
14. Battery 12 V 3 Ah
15. Side Stand Switch
16. Gear Position Switch
17. Starter Lockout Switch

## 15-56 ELECTRICAL SYSTEM

### Lighting System

#### Headlight Aiming Inspection

- Refer to the Headlight Aiming Inspection in the Periodic Maintenance chapter.

#### Headlight Bulb Replacement

- Remove the headlight unit (see Headlight Unit Removal).
- Disconnect the headlight connector [A].
- Remove the dust cover [B].

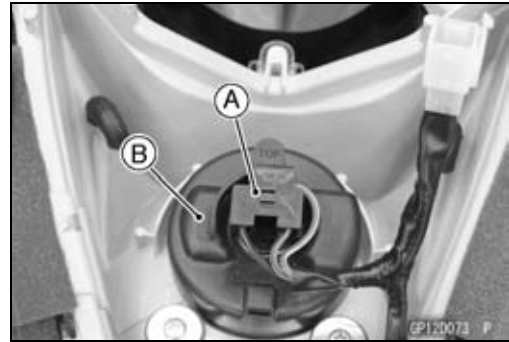

- Clear the hook [A] from the stopper [B].
- Remove the headlight bulb [C].

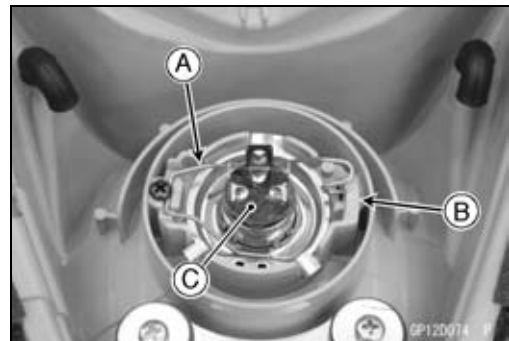

#### NOTICE

When handling the quartz-halogen bulb, never touch the glass portion with bare hands. Always use a clean cloth. Oil contamination from hands or dirty rags can reduce bulb life or cause the bulb to explode. Use the correct type of headlight bulb with specified voltage and wattage only.

#### NOTE

○ Clean off any contamination that inadvertently gets on the bulb with alcohol or soap and water solution.

- Replace the headlight bulb with a new one.
- Fit the projections [A] of the bulb in the hollows [B] of the headlight.

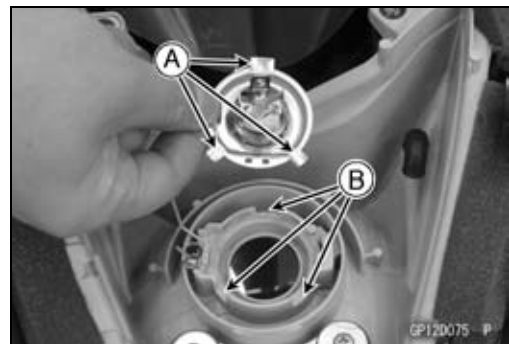

- Install the hook [A] to the stopper [B].

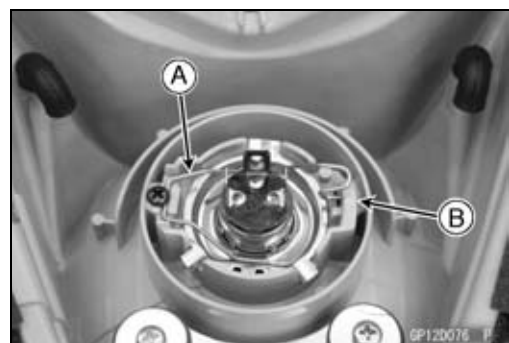



## Lighting System

- Fit the dust cover [A] with the "TOP" mark [B] upward.
- Press the outer circumference of the dust cover a few places with finger to make sure it is fitted securely. If you find any looseness, remove the dust cover and install again.

### NOTICE

**If the dust cover is not securely fitted, the water enters the headlight housing, it can lead to the corrosions in the housing or damage to the electrical system.**

Correct [A]: The dust cover [B] fitted correctly with NO gap.  
Headlight Housing [C]

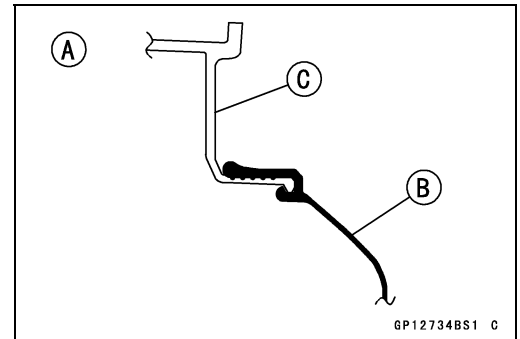
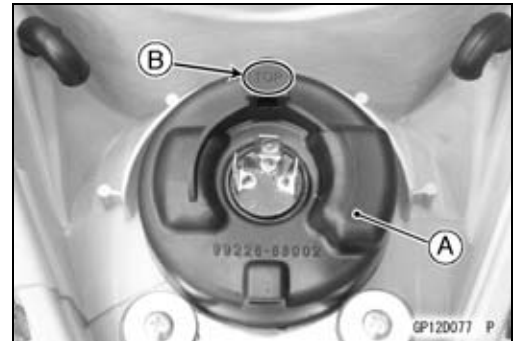

Wrong [D]: The dust cover [E] fitted incorrectly with gaps.  
Headlight Housing [F]

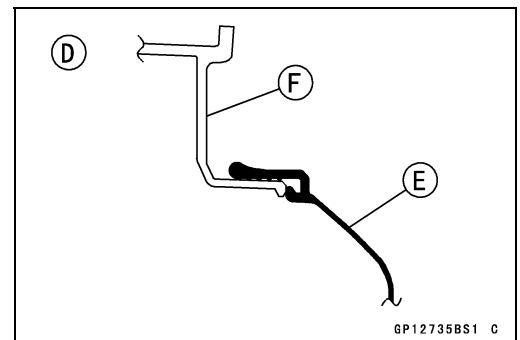

- Install the headlight unit (see Headlight Unit Installation).
- After installation, adjust the headlight aim (see Headlight Aiming Inspection in the Periodic Maintenance chapter).

### Headlight Unit Removal (BR125G/H)

- Remove:
  - Headlight Aiming Adjusting Bolt [A] and Collar Headlight Cover Mounting Bolt [B] (Both Sides)
- Pull the headlight unit [C] forward slightly.

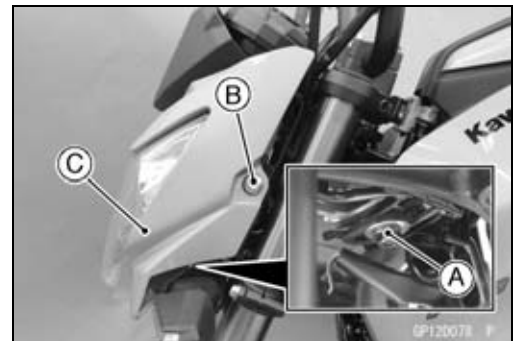

# 15-58 ELECTRICAL SYSTEM

## Lighting System

- Slide the dust cover [A].
- Disconnect the headlight subharness connector [B].

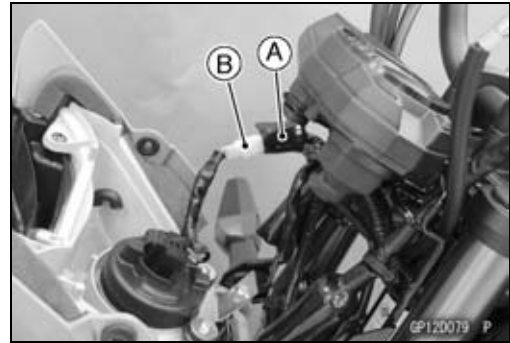

- Remove:
  - Headlight Unit Mounting Screws [A]
  - Clamp [B]
  - Headlight Unit [C]

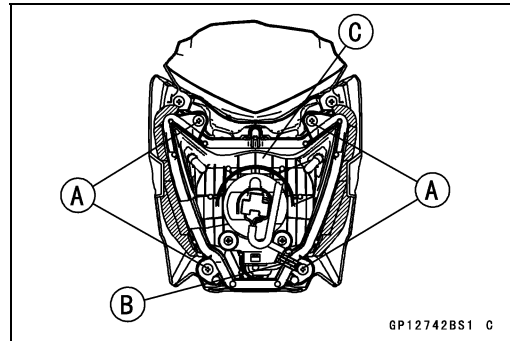

### Headlight Unit Removal (BR125J)

- Remove:
  - Headlight Cover Mounting Bolt [A] (Both Sides)
- Pull up the headlight unit [B] and remove it from the bracket.

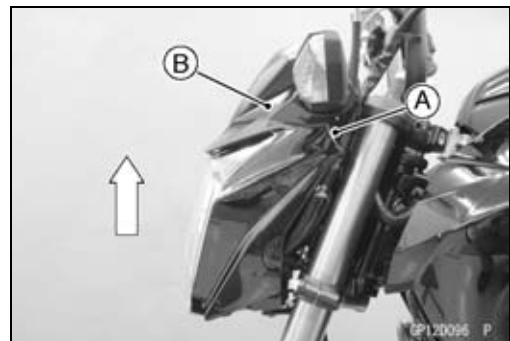

- Remove the front turn signal light lead connectors [A] from the bracket.



- Disconnect the front turn signal light lead connectors [A].
- Slide the dust cover [B].
- Disconnect the headlight subharness connector.

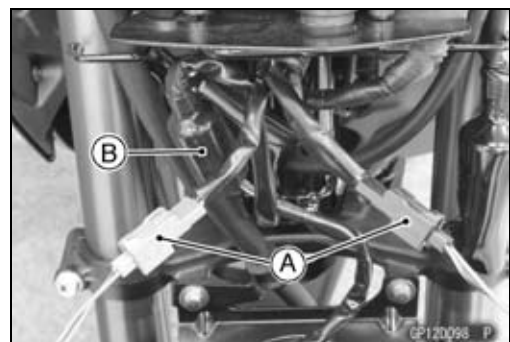

## Lighting System

- Remove:
  - Headlight Unit Mounting Screws [A]
  - Headlight Unit [B]

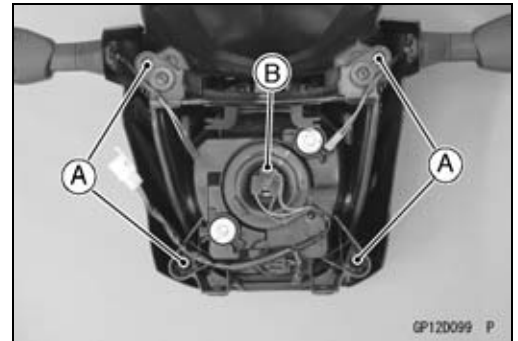

### Headlight Unit Installation (BR125G/H)

- Installation is the reverse of removal.
- Check that the grommets [A], collars [B], damper [C] and pads [D] are in place on the headlight cover.

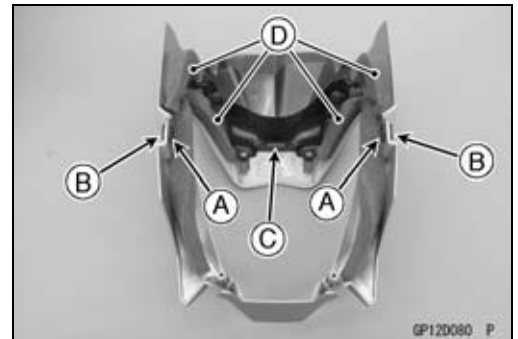

- Fit the damper [A] on the headlight cover to the groove [B] of the headlight unit.
- Tighten the headlight unit mounting screws with the clamp securely.
- Run the leads correctly (see Cable, Wire, and Hose Routing section in the Appendix chapter).
- Install the removed parts (see appropriate chapters).
- After installation, adjust the headlight aim (see Headlight Aiming Inspection in the Periodic Maintenance chapter).

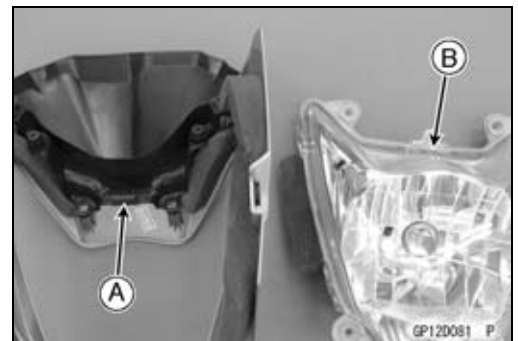

### Headlight Unit Installation (BR125J)

- Installation is the reverse of removal.
- Check that the damper [A] is in place on the headlight cover.



- Fit the damper [A] on the headlight cover to the groove [B] of the headlight unit.
- Tighten the headlight unit mounting screws securely.

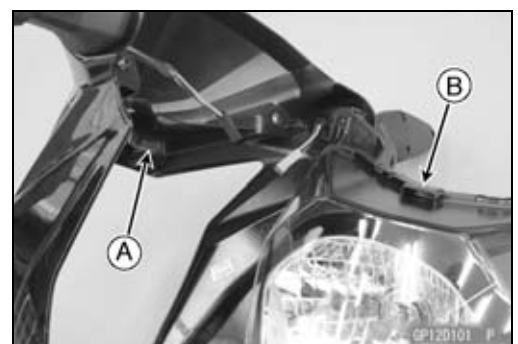

# 15-60 ELECTRICAL SYSTEM

## Lighting System

- Check that the grommets [A] are in place on the headlight unit.
- Run the leads correctly (see Cable, Wire, and Hose Routing section in the Appendix chapter).



- Insert the grommets [A] to the projections [B].
- Install the removed parts (see appropriate chapters).
- After installation, adjust the headlight aim (see Headlight Aiming Inspection in the Periodic Maintenance chapter).

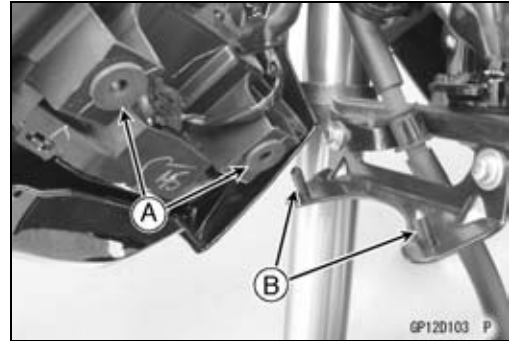

### City Light Bulb Replacement

- Remove the headlight unit (see Headlight Unit Removal).

#### BR125G/H

- Clear the city light lead from the clamp [A], and pull out the socket [B] from the headlight.

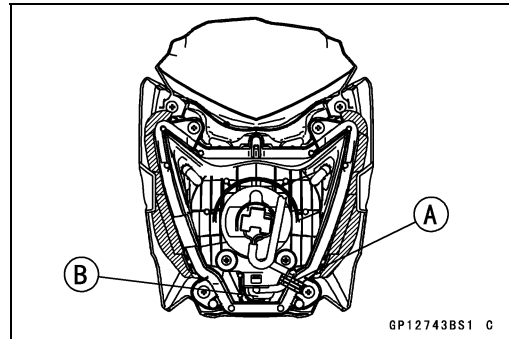

#### BR125J

- Pull out the socket [A] from the headlight.

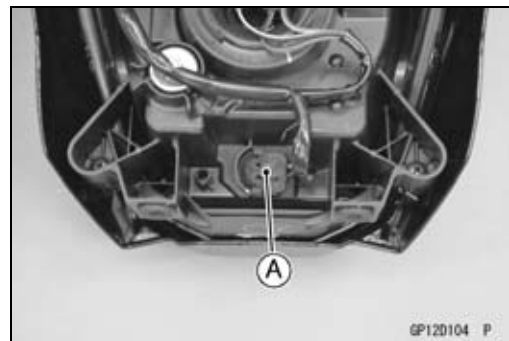

## Lighting System

- Pull out the bulb [A] straight from the socket [B].

### NOTICE

**Do not turn the bulb. Pull the bulb out to prevent damage to the bulb. Do not use bulb rated for greater wattage than the specified value.**

- Replace the city light bulb with a new one.
- Insert the new bulb [A] into the socket [B].
- Install the removed parts (see appropriate chapters).

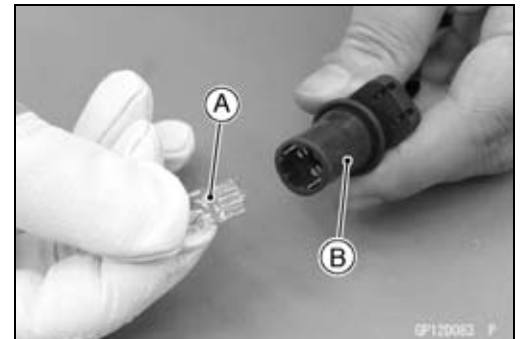
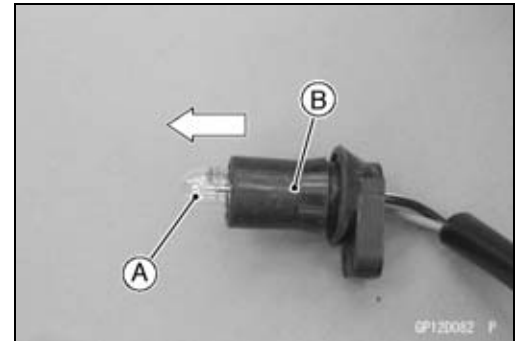

### Tail/Brake Light (LED) Removal

- Remove:
  - Side Seat Covers (see Seat Cover Removal in the Frame chapter)
  - Clamp [A]
  - Screws [B]
- Disconnect the tail/brake light lead connector [C].

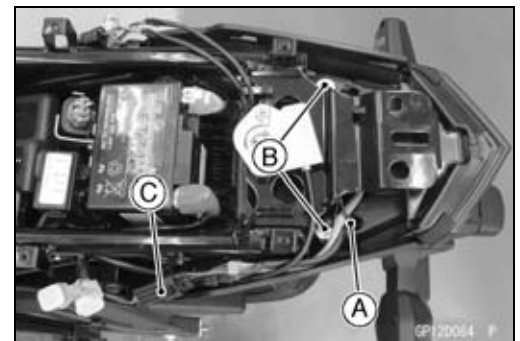

- Remove the tail/brake light (LED) [A] while pulling the both sides of the rear fender [B] outward to clear it off from the tail/brake light (LED).

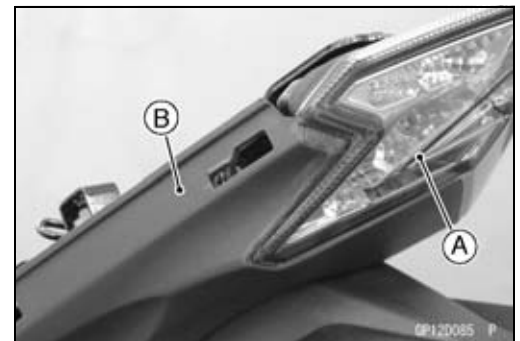

### Tail/Brake Light (LED) Installation

- Installation is the reverse of removal.
- Check that the grommets [A] and dampers [B] are in place on the tail/brake light (LED).
- Run the leads correctly (see Cable, Wire, and Hose Routing section in the Appendix chapter).

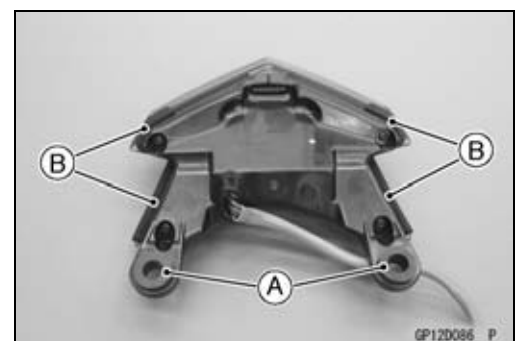

## 15-62 ELECTRICAL SYSTEM

### Lighting System

#### License Plate Light Bulb Replacement

- Remove:
  - License Plate Light Cover Screws [A]
  - License Plate Light Cover [B] and Lens

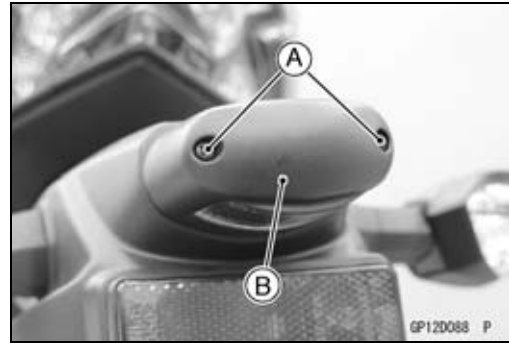

- Pull out the bulb [A] straight from the socket [B].

#### **NOTICE**

**Do not turn the bulb. Pull the bulb out to prevent damage to the bulb. Do not use bulb rated for greater wattage than the specified value.**

- Replace the license plate light bulb with a new one.

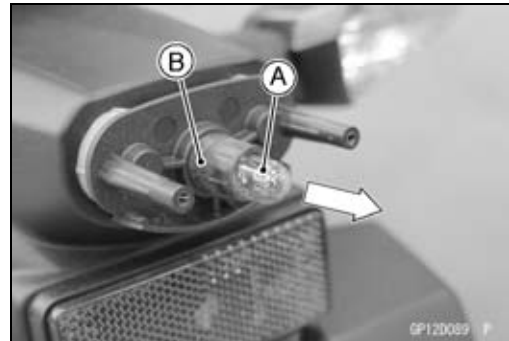

- Insert the new bulb [A] into the socket [B].
- Install the license plate light cover.
- Tighten the license plate light cover screws.

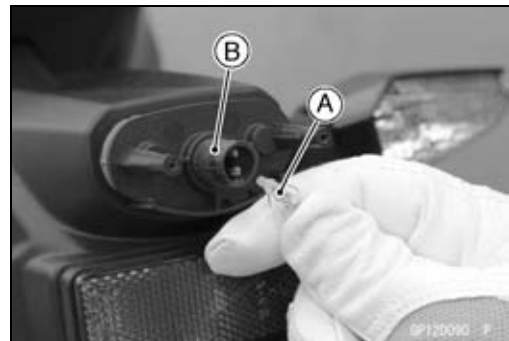

Lighting System

Headlight, Tail/Brake Light Circuit

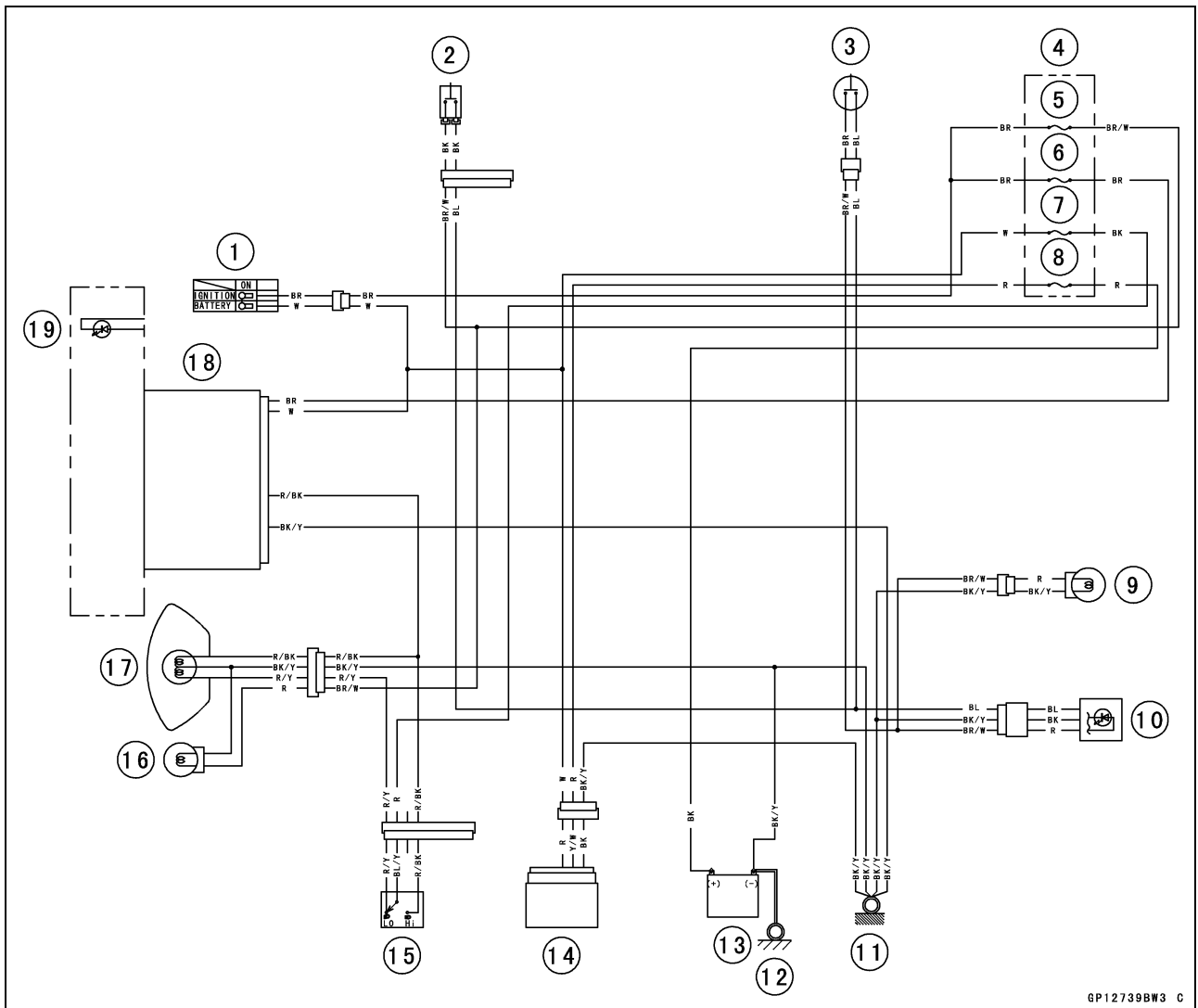

GP12739BW3 C

1. Ignition Switch
2. Front Brake Light Switch
3. Rear Brake Light Switch
4. Fuse Box
5. Headlight Fuse 15 A
6. Ignition Fuse 10 A
7. Battery Fuse 20 A
8. Regulator Fuse 10 A
9. License Plate Light 12 V 5 W
10. Tail/Brake Light (LED)
11. Frame Ground
12. Engine Ground
13. Battery 12 V 3 Ah
14. Regulator/Rectifier
15. Dimmer Switch
16. City Light 12 V 5 W
17. Headlight 12 V 35/35 W
18. Meter Unit
19. Blue High Beam Indicator Light (LED)

## 15-64 ELECTRICAL SYSTEM

### Lighting System

#### Turn Signal Light Bulb Replacement

- Remove:
  - Turn Signal Light Lens Screws [A]
- Remove the turn signal light lens [A].
- Push and turn the bulb [A] counterclockwise and remove it.
- Insert the new bulb [A] by aligning its pins [B] with the grooves [C] in the socket, and turn the bulb clockwise.
- Install the turn signal light lens.
- Tighten:
  - Torque - Turn Signal Light Lens Screws: 1.0 N·m (0.10 kgf·m, 8.9 in·lb)**

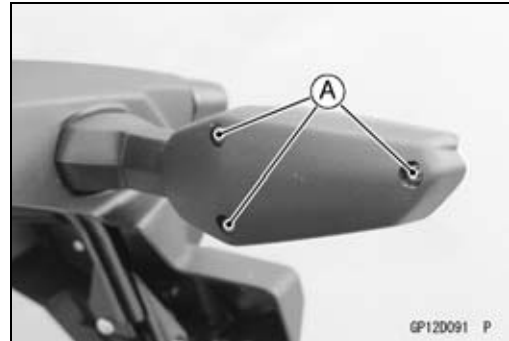



## Lighting System

## Turn Signal Light Circuit

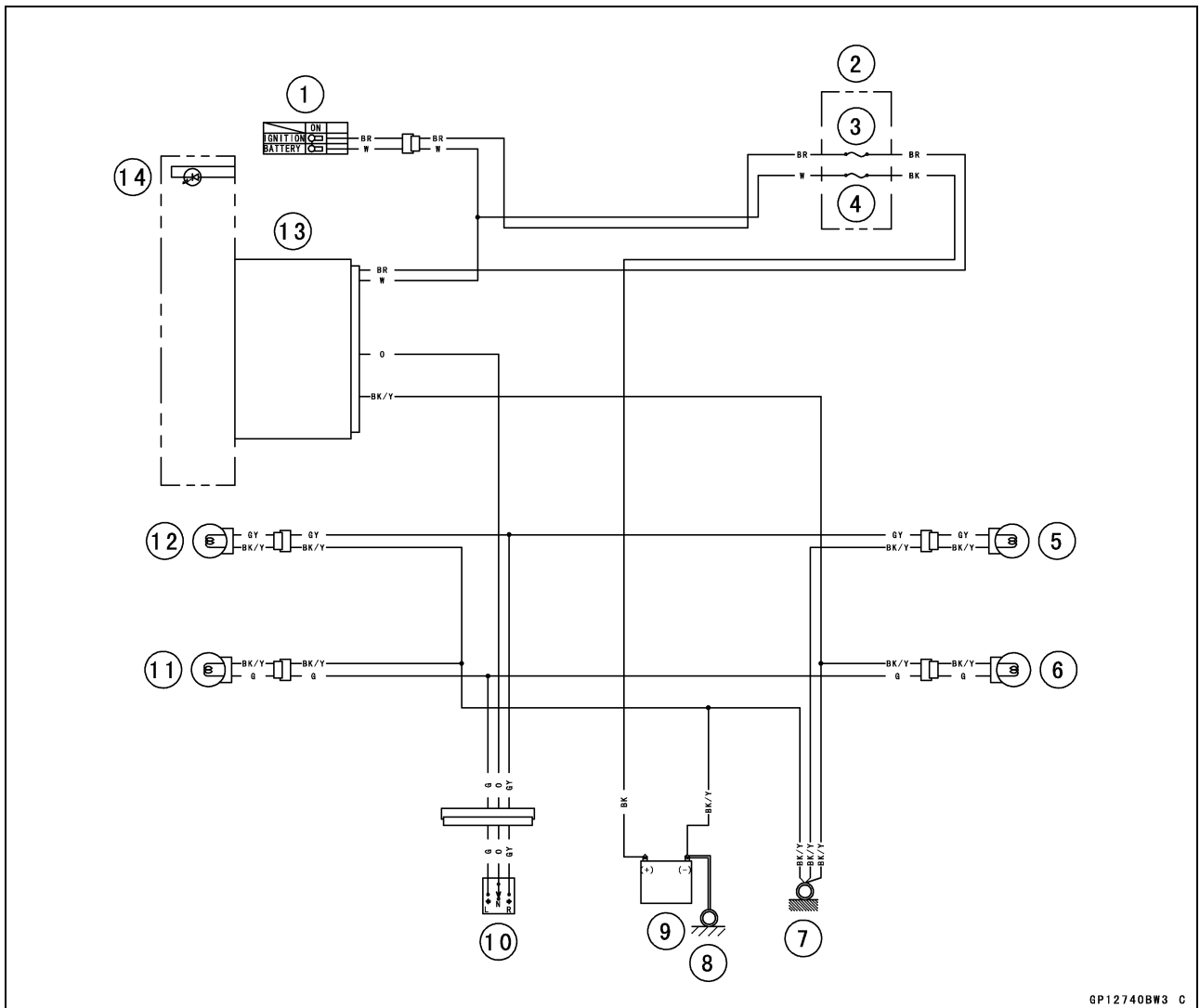

GP12740BW3 C

1. Ignition Switch
2. Fuse Box
3. Ignition Fuse 10 A
4. Battery Fuse 20 A
5. Rear Right Turn Signal Light 12 V 10 W
6. Rear Left Turn Signal Light 12 V 10 W
7. Frame Ground
8. Engine Ground
9. Battery 12 V 3 Ah
10. Turn Signal Switch
11. Front Left Turn Signal Light 12 V 10 W
12. Front Right Turn Signal Light 12 V 10 W
13. Meter Unit
14. Green Turn Signal Indicator Light (LED)

## 15-66 ELECTRICAL SYSTEM

### Meter, Gauge, Indicator Unit

#### Meter Unit Removal

- Remove the headlight unit (see Headlight Unit Removal).
- Slide the dust cover [A].
- Disconnect the meter unit lead connector [B].
- Remove the screws [C] and washers.
- Remove the meter unit [D].

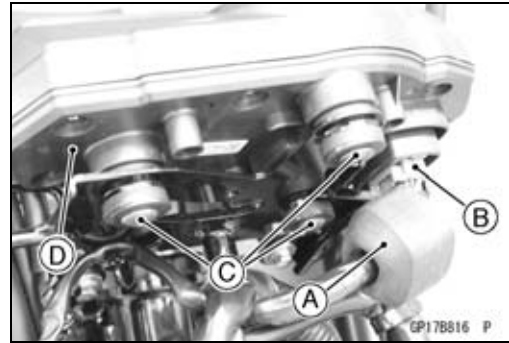

#### Meter Unit Installation

- Installation is the reverse of removal.
- Run the leads and cable correctly (see Cable, Wire, and Hose Routing section in the Appendix chapter).
- Check that the grommets [A] are in place on the bracket [B].

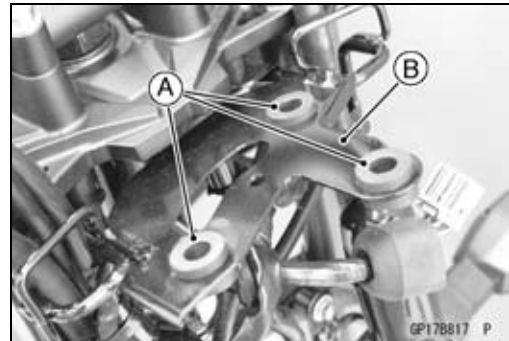

- Insert the projections [A] of the meter unit to the grommets [B].

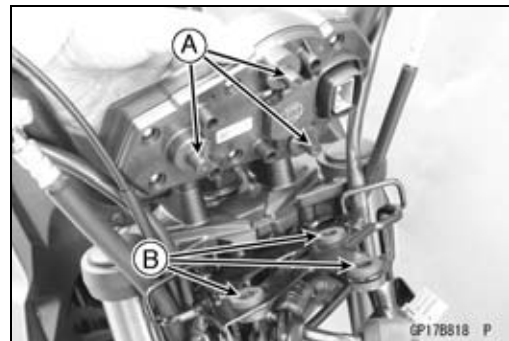

#### Meter Operation Inspection

##### Check 1: Meter Unit Switching Inspection

##### Display Mode Setting

- Turn the ignition switch on and check the following.
- By pushing the upper meter button [A] each time, check that the display [B] changes as shown.

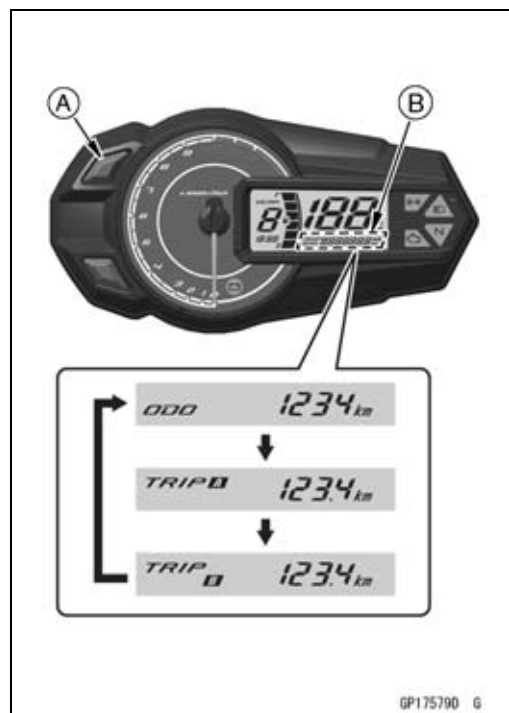

## Meter, Gauge, Indicator Unit

### Unit Setting

- Set the ODO mode by pushing the upper meter button.
- By pushing the lower meter button while the upper meter button pushed in, check that the display changes as shown.

### NOTE

○Mile/Km display can alternate between English and metric modes (mile and km) in the digital meter. Make sure that km or mile according to local regulations is correctly displayed before riding.

- ★If the display function does not work, replace the meter unit.

### Clock Setting

- Set the ODO mode [A] by pushing the upper meter button [B].
- Push the lower meter button [C] for more than two seconds.
- The clock setting menu (hour and minute) should blink.
- Push the lower meter button.

○The hour display [A] starts blinking.

- By pushing the upper meter button each time, check that the hour display changes.

- By pushing the lower meter button, check that the hour display decides and minute display [A] starts blinking.
- By pushing the upper meter button each time, check that the minute display changes.

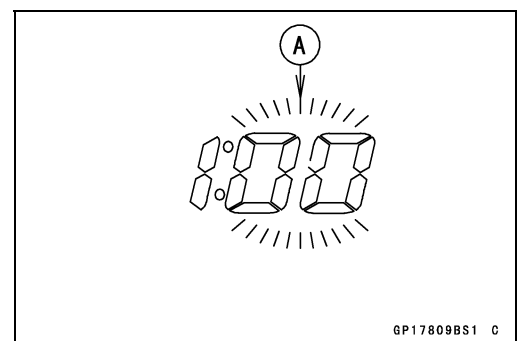
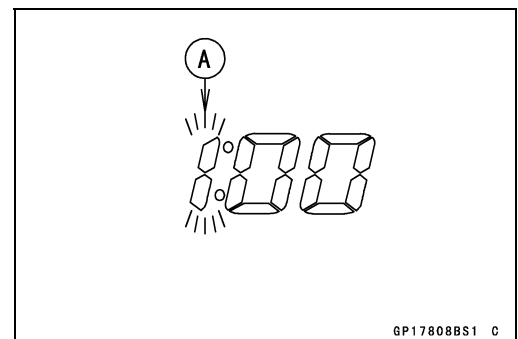
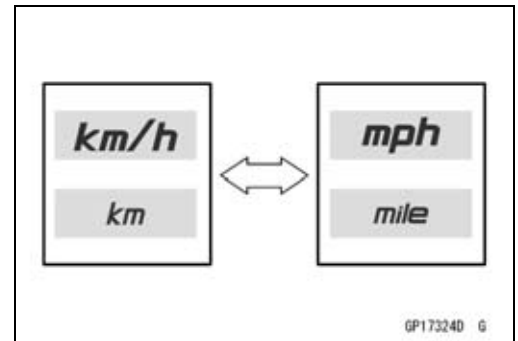

## 15-68 ELECTRICAL SYSTEM

### Meter, Gauge, Indicator Unit

- By pushing the lower meter button, check that the hour and minute display start blinking.
- By pushing the upper meter button, check that the hour and minute display decide.
- When both hour and minute display is blinking, by pushing the lower meter button, check that the hour display start blinking. This blinking returns the hour setting display.
- ★ If the display function does not work, replace the meter unit.

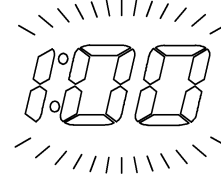

GP17810BS1 C

#### **Meter System Inspection**

##### **Check 2-1: Red Battery Warning Indicator Light (LED) Inspection**

- When the battery condition is low voltage (10.8 ~ 11.2 V or less) or high voltage (15.5 ~ 16.5 V or more), the red battery warning indicator light (LED) [A] goes on.
- ★ If the red battery warning indicator light (LED) goes on, inspect the charging voltage (see Charging Voltage Inspection).
- ★ If the charging voltage is good, replace the meter unit.



GP17581D G

##### **Check 2-2: Gear Position Indicator Inspection**

- Turn the ignition switch on.
- The green neutral indicator light (LED) [A] goes on when the transmission gear is neutral position.



GP17582D G

- Set the low gear position, and check that the display changes to 1 mark [A] and the green neutral indicator light (LED) goes off.
- Using the rear stand, raise the rear wheel off the ground.
- Rotate the rear wheel by hand, and change the gear position.
- Check that the display corresponding to each gear position (1, 2, 3 or 4) appears.
- ★ If the display function does not work, check the following parts.
  - Gear Position Switch (see Gear Position Switch Inspection)
  - Wiring (see Meter Unit Circuit)
- ★ If the above parts are good, replace the meter unit.

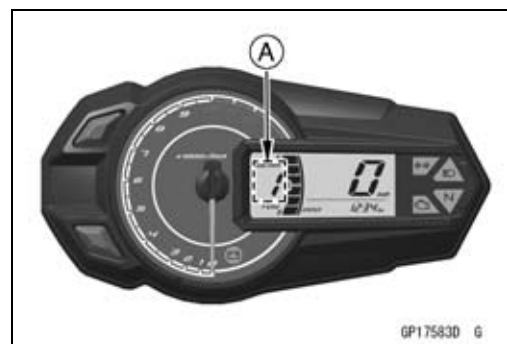

GP17583D G

##### **Check 2-3: Green Turn Signal Indicator Light (LED) Inspection**

- Check the green turn signal light indicator light (LED) operation (see Lights and Switches Operation Inspection in the Periodic Maintenance chapter).
- ★ If the green turn signal light indicator light (LED) does not work, check the wiring to the meter unit (see Meter Circuit).
- ★ If the wiring is good, replace the meter unit (see Meter Unit Removal/Installation).

## Meter, Gauge, Indicator Unit

### Meter Unit Inspection

- Remove the meter unit [A] (see Meter Unit Removal).
  - [1] Ignition (+)
  - [2] Battery (+)
  - [3] Gear Position Indicator (1) (-)
  - [4] Gear Position Indicator (2) (-)
  - [5] Gear Position Indicator (3) (-)
  - [6] Gear Position Indicator (4) (-)
  - [7] Green Neutral Signal Indicator Light (LED) (-)
  - [8] Unused
  - [9] Green Turn Signal Indicator Light (LED)
  - [10] Blue High Beam Indicator Light (LED) (+)
  - [11] Fuel Gauge
  - [12] Unused
  - [13] Ground (-)
  - [14] Speed Sensor Signal
  - [15] Tachometer Pulse
  - [16] Yellow Engine Warning Indicator Light (LED) (-)

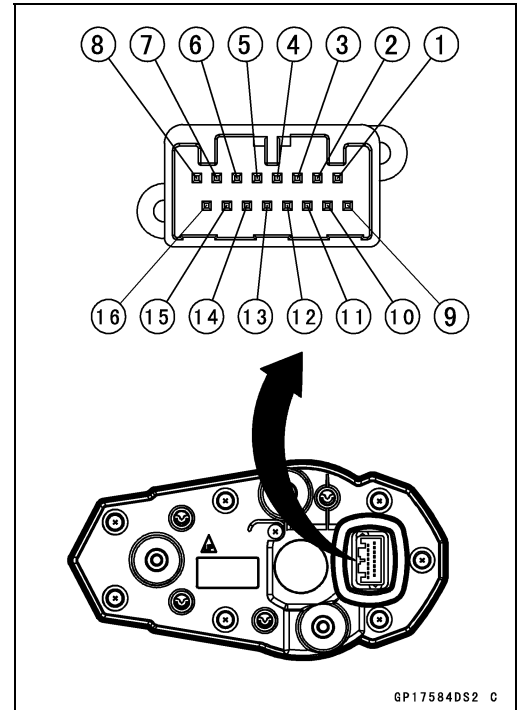

### Check 3-1: Meter Unit Primary Operation Check

- Using the auxiliary leads, connect the 12 V battery to the meter unit connector as follows.
  - Connect the battery positive (+) terminal to the terminal [2].
  - Connect the battery negative (-) terminal to the terminal [13].

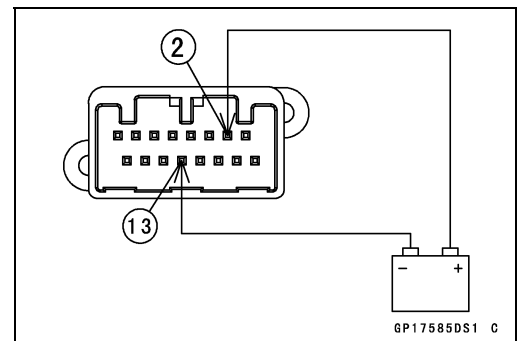

- Connect the terminal [1] to the battery (+) terminal.

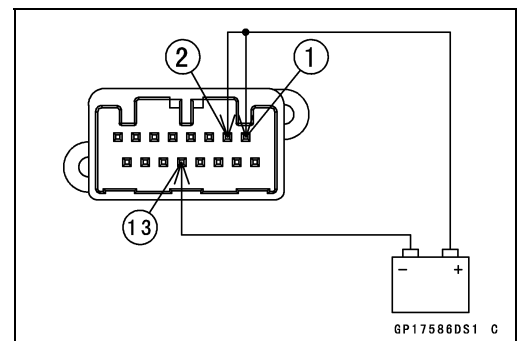

- Check the following items.
  - All the LCD segments [A] appear and all the indicator lights (LED) [B] go on for about 1 second.
  - Then the tachometer needle [C] sweeps to the maximum reading, then sweeps back to the minimum reading.
- ★ If the meter unit does not work, replace the meter unit.

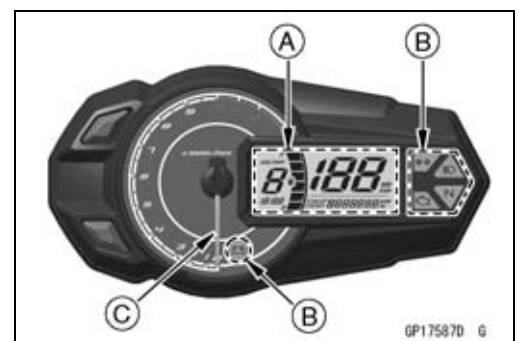

# 15-70 ELECTRICAL SYSTEM

## Meter, Gauge, Indicator Unit

- About 5 seconds after, the all fuel level gauge segments and fuel level warning indicator start blinking [A].
- ★If the fuel level gauge does not blink, replace the meter unit.

### NOTE

○This meter unit has a failure detection function (for open or short) of the fuel gauge. When the fuel level gauge is open or short, the meter unit alerts the rider by the all fuel level gauge segments and fuel level warning indicator blink in the display.

- Disconnect the terminal [1].
- All the LCD segments disappear.
- ★If the segments do not disappear, replace the meter unit.

### Check 3-2: Blue High Beam Indicator Light (LED) Inspection

- Connect the leads in the same circuit as Check 3-1.
- Connect the terminal [10] to the battery (+) terminal.

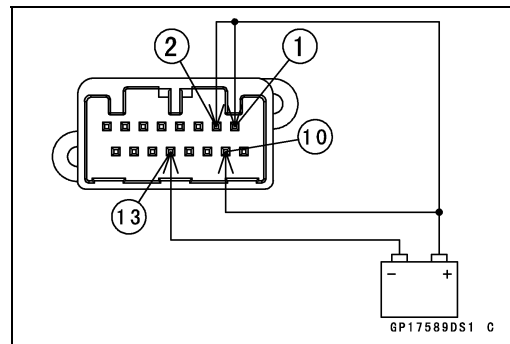
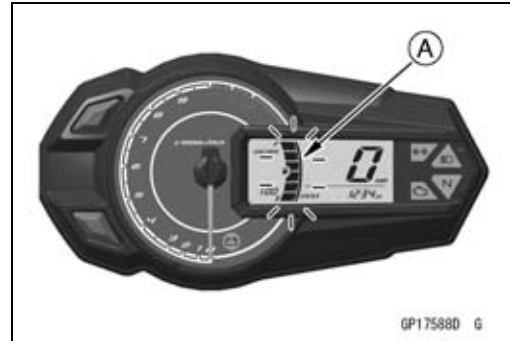

- Check that the blue high beam indicator light (LED) [A] goes on.
- ★If the indicator light (LED) does not go on, replace the meter unit.



### Check 3-3: Green Neutral Indicator Light (LED) Inspection

- Connect the leads in the same circuit as Check 3-1.
- Connect the terminal [7] to the battery (-) terminal.

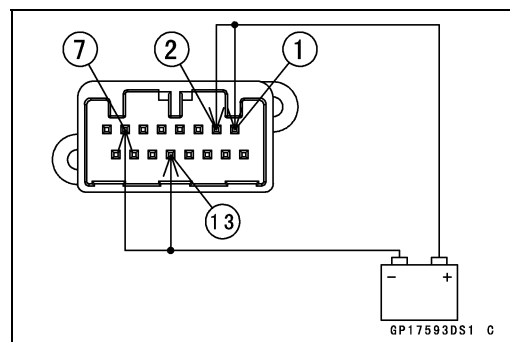

**Meter, Gauge, Indicator Unit**

- Check that the green neutral indicator light (LED) [A] goes on.
- ★ If the indicator light (LED) does not go on, replace the meter unit.



**Check 3-4: Gear Position Indicator Inspection**

- Connect the leads in the same circuit as Check 3-1.
- Connect the terminal [3] to battery (-) terminal.

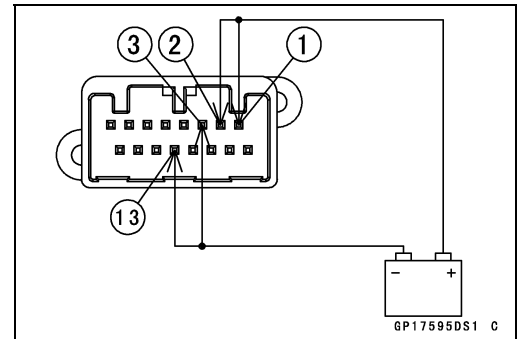

- Check that the display changes 1 mark [A].
- ★ If the gear position indicator does not work, replace the meter unit.

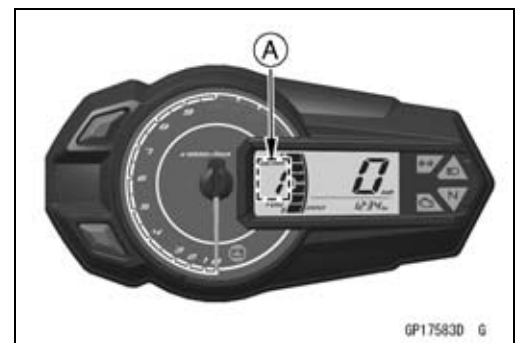

- Connect the leads in the same circuit as Check 3-1.
- Connect the terminal [4] to battery (-) terminal.

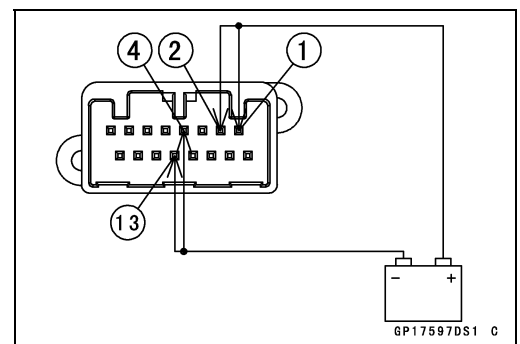

- Check that the display changes 2 mark [A].
- ★ If the gear position indicator does not work, replace the meter unit.

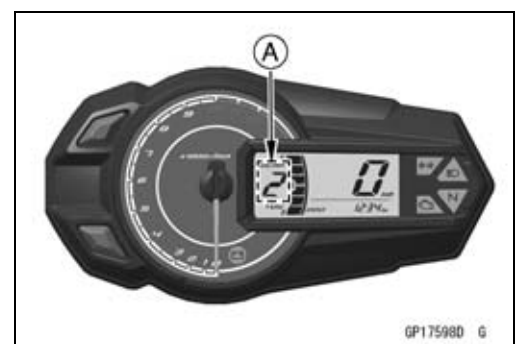

## 15-72 ELECTRICAL SYSTEM

### Meter, Gauge, Indicator Unit

- Connect the leads in the same circuit as Check 3-1.
- Connect the terminal [5] to battery (-) terminal.

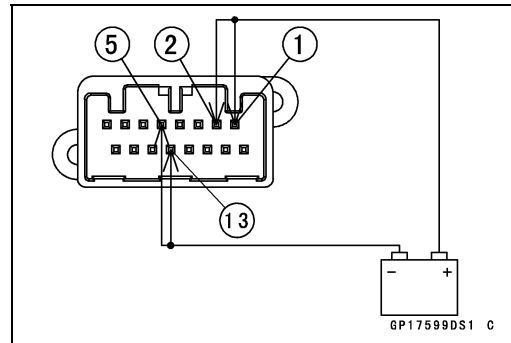

- Check that the display changes 3 mark [A].
- ★ If the gear position indicator does not work, replace the meter unit.

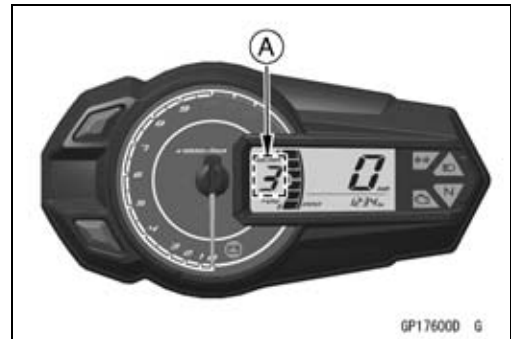

- Connect the leads in the same circuit as Check 3-1.
- Connect the terminal [6] to battery (-) terminal.

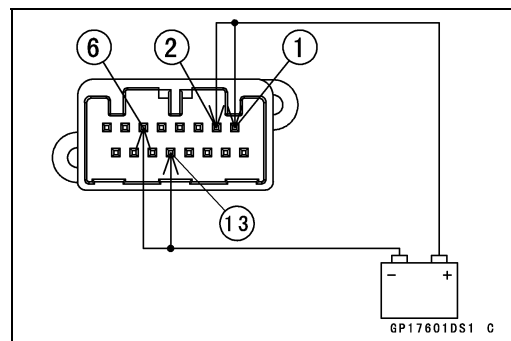

- Check that the display changes 4 mark [A].
- ★ If the gear position indicator does not work, replace the meter unit.

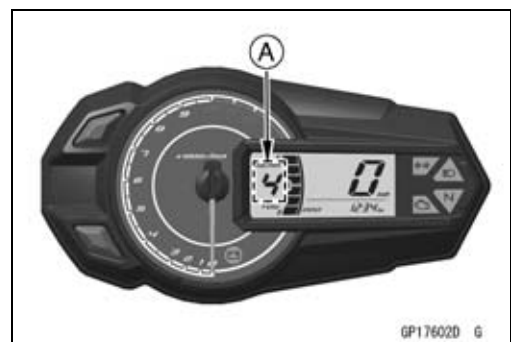

#### Check 3-5: Yellow Engine Warning Indicator Light (LED) Inspection

- Connect the leads in the same circuit as Check 3-1.
- Connect the terminal [16] to the battery (-) terminal.

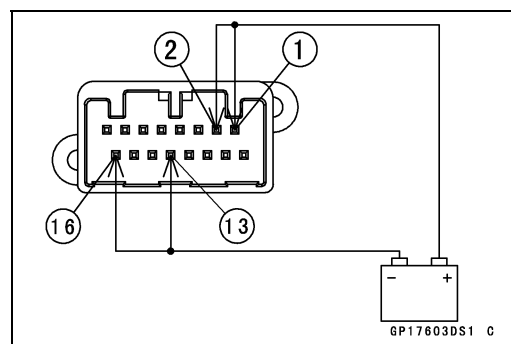



**Meter, Gauge, Indicator Unit**

- Check that the yellow engine warning indicator light (LED) [A] goes on.
- ★ If the indicator light (LED) does not go on, replace the meter unit.



**Check 3-6: Fuel Gauge Inspection**

- Connect the leads in the same circuit as Check 3-1.
- The all segments of the fuel gauge in the display will blink.
- Connect the variable rheostat [A] to the terminal [11] and the battery (-) terminal.

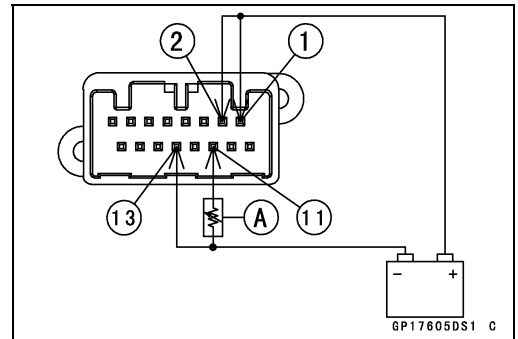

- Check that the number of segments on the fuel gauge [A] matches the resistance value of the variable rheostat.
- When the terminal [2] is connected, 1 segment in the fuel level gauge should appear about every 5 seconds.

Variable Rheostat Resistance (Ω)	Display Segments
20	6 segments go on
60	5 segments go on
80	4 segments go on
110	3 segments go on
150	2 segments go on
200	1 segment goes on
220	1 segment blinks

- ★ If the display function does not work, replace the meter unit.

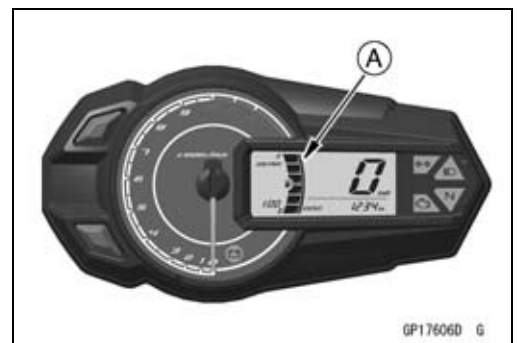

# 15-74 ELECTRICAL SYSTEM

## Meter, Gauge, Indicator Unit

### Check 3-7: Speedometer Inspection

- Connect the leads in the same circuit as Check 3-1.
- The speed equivalent to the input frequency is indicated in the oscillator [A], if the square wave is input into terminal [14].
- Indicates approximately 60 km/h if the input frequency is approximately 772.4 Hz.
- Indicates approximately 60 mph if the input frequency is approximately 1235.9 Hz.
- ★ If the meter function does not work, replace the meter unit.

#### NOTE

- The input frequency of the oscillator adds the integrated value of the odometer.
- The integrated value of the odometer cannot be reset.

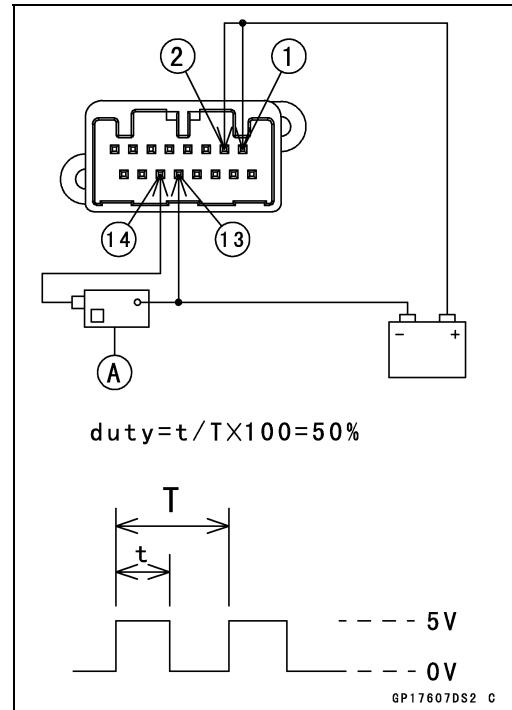

### Check 3-8: Odometer Check

- Check the odometer with the speedometer check in the same way.
- ★ If value indicated in the odometer is not added, replace the meter unit.

#### NOTE

- The data is maintained even if the battery is disconnected.
- When the figures come to 999999, they are stopped and locked.
- The integrated value of the odometer cannot be reset.

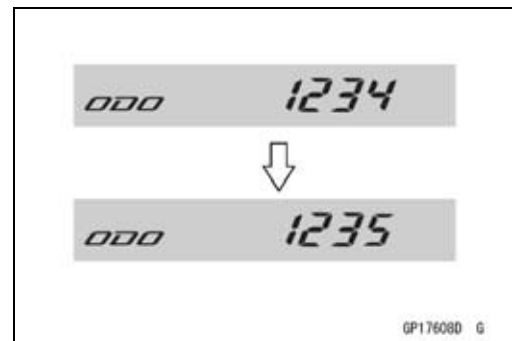

### Check 3-9: Trip A/B Meter Check

- Check the trip meter with the speedometer in the same way.
- ★ If value indicated in the trip meter is not added, replace the meter unit.

#### NOTE

- The integrated value of the odometer cannot be reset.
- Check that when the lower meter button is pushed for more than two seconds, the figure display turns to 0.0.
- ★ If the figure display does not indicate 0.0, replace the meter unit.

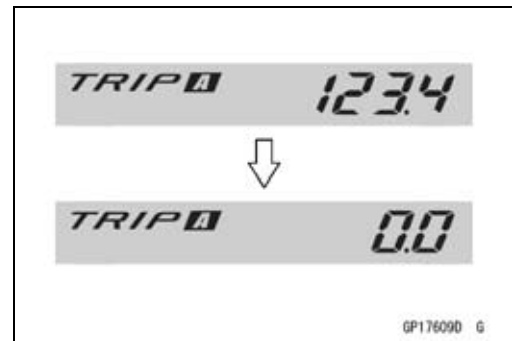

## Meter, Gauge, Indicator Unit

### Check 3-10: Tachometer Inspection

- Connect the leads in the same circuit as Check 3-1.
- The engine speed (rpm) equivalent to the input frequency is indicated in the oscillator [A], if the square wave is input into terminal [15].
- Indicates approximately 6 000 rpm if the input frequency is approximately 50 Hz.
- ★ If the meter function does not work, replace the meter unit.

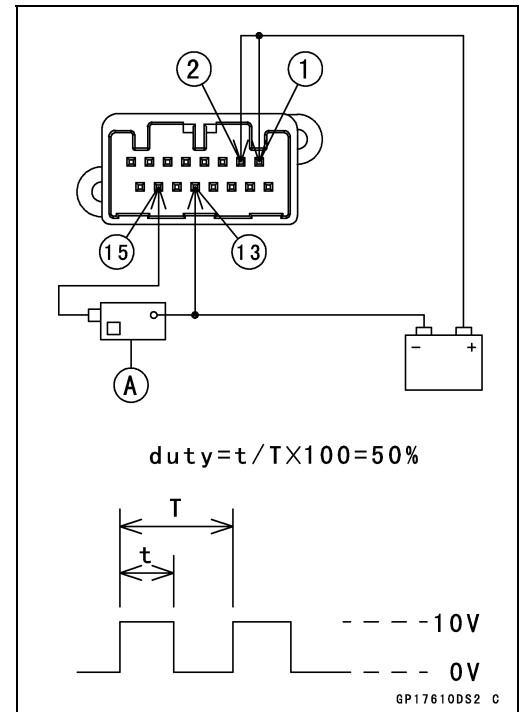

### Fuel Level Sensor Line Self-Diagnosis Mode Inspection

#### NOTE

- Usually when the open or short of the fuel level sensor circuit is detected, it becomes the Fuel Level Sensor Line Self-Diagnosis Mode.
- The all segments of the fuel level gauge and fuel level warning indicator [A] in the display will blink (This function is Fuel Level Sensor Line Self-Diagnosis Mode.).
- ★ If the meter enters the self-diagnosis mode when the meter is installed in the motorcycle, check the fuel level sensor (see Fuel Level Sensor Inspection) and wiring.
- ★ If the fuel level sensor and wiring are good, replace the meter unit.

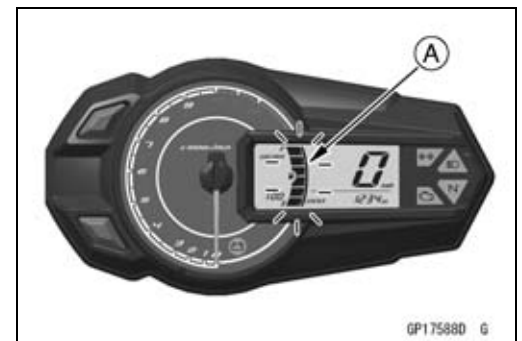

# 15-76 ELECTRICAL SYSTEM

## Meter, Gauge, Indicator Unit

### Meter Circuit

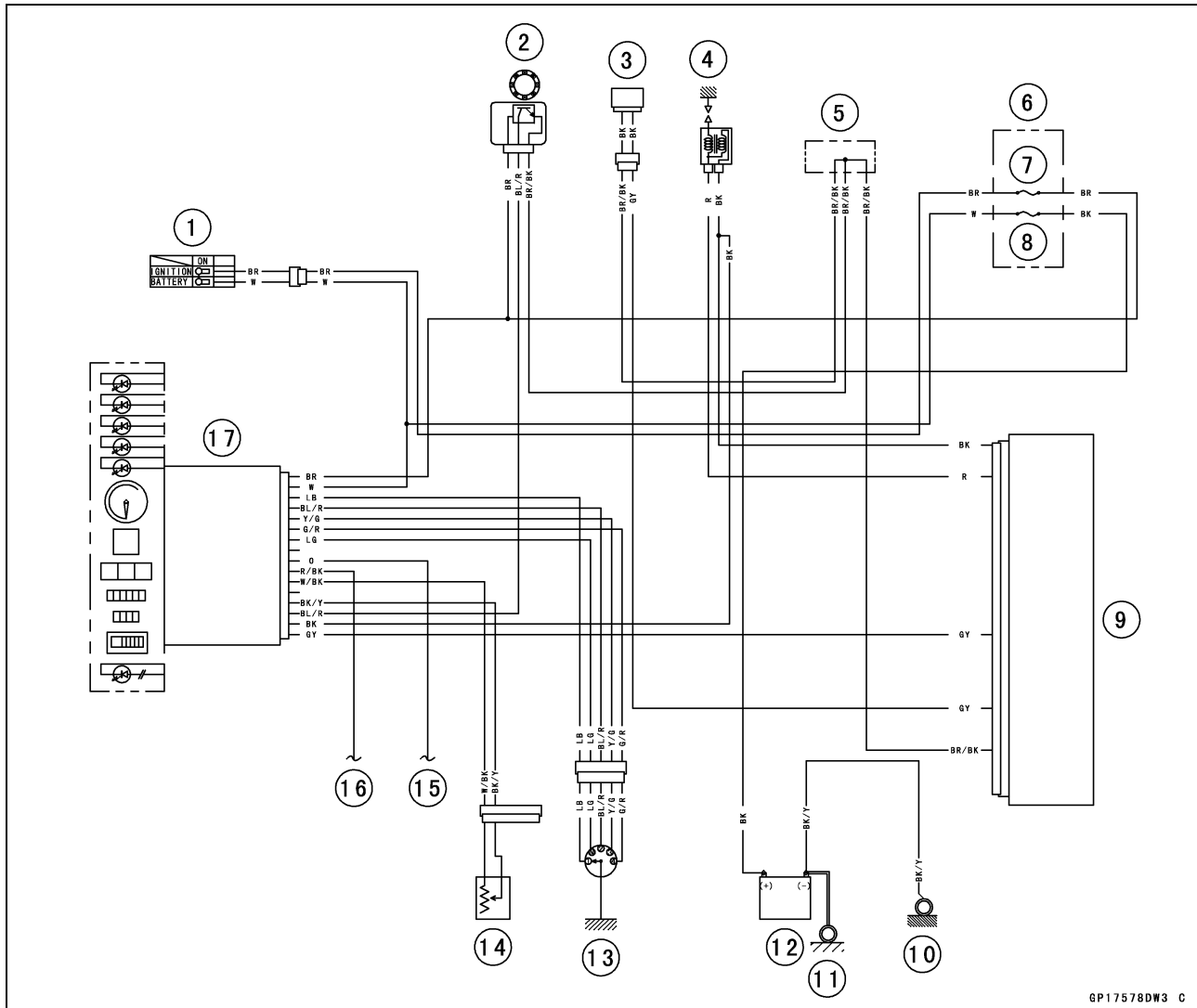

GP17578DW3 C

1. Ignition Switch
2. Speed Sensor
3. Engine Temperature Sensor
4. Ignition Coil
5. Water-proof Joint
6. Fuse Box
7. Ignition Fuse 10 A
8. Battery Fuse 20 A
9. ECU
10. Frame Ground
11. Engine Ground
12. Battery 12 V 3 Ah
13. Gear Position Switch
14. Fuel Level Sensor
15. To Turn Signal Switch
16. To Dimmer Switch
17. Meter Unit

## Switches and Sensors

### **Brake Light Timing Inspection**

- Refer to the Brake Light Switch Operation Inspection in the Periodic Maintenance chapter.

### **Brake Light Timing Adjustment**

- Refer to the Brake Light Switch Operation Inspection in the Periodic Maintenance chapter.

### **Switch Inspection**

- Using a tester, check to see that only the connections shown in the table have continuity (about zero ohms).
- For the switch housings and the ignition switch, refer to the tables in the Wiring Diagram.
- ★ If the switch has an open or short, repair it or replace it with a new one.

#### **Rear Brake Light Switch Connections**

Rear Brake Light Switch Connections		
Color	BR	BL
When brake pedal is pushed down		
When brake pedal is released		

#### **Side Stand Switch Connections (BR125J)**

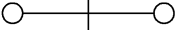
Side Stand Switch Connections		
Color	BK	G
When side stand is down		
When side stand is up		

#### **Starter Lockout Switch Connections (BR125H/J)**

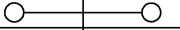
Starter Lockout Switch		
Color	G/W	BL/R
Clutch Lever		
Pulled in		
Released		

GP18754BN3 C

# 15-78 ELECTRICAL SYSTEM

## Switches and Sensors

### Engine Temperature Sensor Inspection

- Remove the engine temperature sensor (see Engine Temperature Sensor Removal/Installation in the Fuel System (DFI) chapter).
- Suspend the sensor [A] in a container of machine oil so that the heat-sensitive portion and threaded portion are submerged.
- Suspend an accurate thermometer [B] with heat-sensitive portions [C] located in almost the same depth.

#### NOTE

- The sensor and thermometer must not touch the container side or bottom.
- Place the container over a source of heat and gradually raise the temperature of the oil while stirring the oil gently for even temperature.
- Using the digital meter, measure the internal resistance of the sensor.
- ★ If the measurement is out of the specified range, replace the sensor.

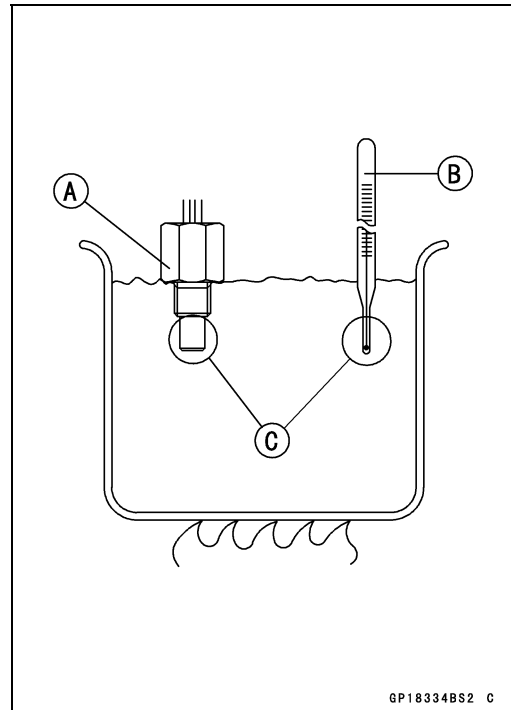

### Engine Temperature Sensor Resistance

Temperature	Resistance
20°C (68°F)	12.17 ~ 13.92 kΩ
40°C (104°F)	5.704 ~ 6.724 kΩ
60°C (140°F)	2.893 ~ 3.502 kΩ
80°C (176°F)	1.569 ~ 1.945 kΩ
100°C (212°F)	0.9025 ~ 1.142 kΩ
120°C (248°F)	0.5460 ~ 0.7041 kΩ
140°C (284°F)	0.3453 ~ 0.4530 kΩ

### Speed Sensor Removal

- Disconnect the speed sensor connector [A].
- Remove:
  - Bolt [B]
  - Speed Sensor [C]

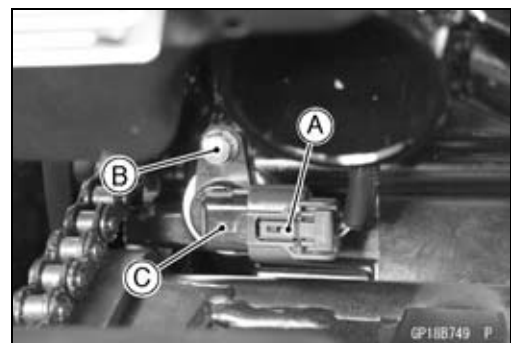

### Speed Sensor Installation

- Installation is the reverse of removal.
- Apply grease to the O-ring [A].
- Tighten:
  - Torque - Speed Sensor Bolt: 5.2 N·m (0.53 kgf·m, 46 in·lb)



## Switches and Sensors

### Speed Sensor Inspection

- Remove the speed sensor (see Speed Sensor Removal).
- Connect the speed sensor connector [A] with the battery [B], 10 kΩ resistor [C] and tester [D] as shown.

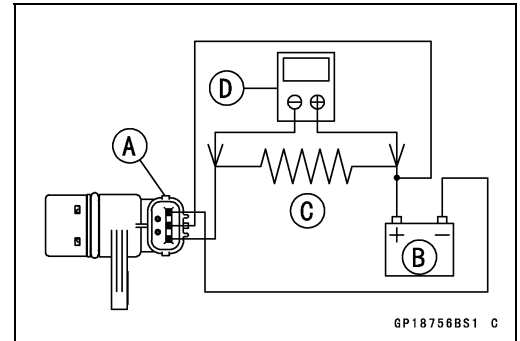

- Trace [A] each side of the speed sensor surface with the screwdriver.
- Then the tester indicator should flick [B].
- ★ If the tester indicator does not flick, replace the speed sensor.

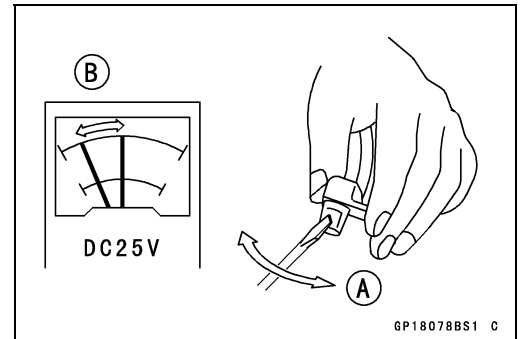

### Oxygen Sensor Removal

#### NOTICE

Never drop the sensor especially on a hard surface. Such a shock to the sensor can damage it.

#### NOTICE

Do not pull strongly, twist, or bend the oxygen sensor lead. This may cause the wiring open.

- Remove:
  - Lower Fairing (see Lower Fairing Removal in the Frame chapter)
- Disconnect the oxygen sensor lead connector [A].
- Clear the oxygen sensor lead from the guides [B] of the clutch cover.
- Remove the oxygen sensor [C].

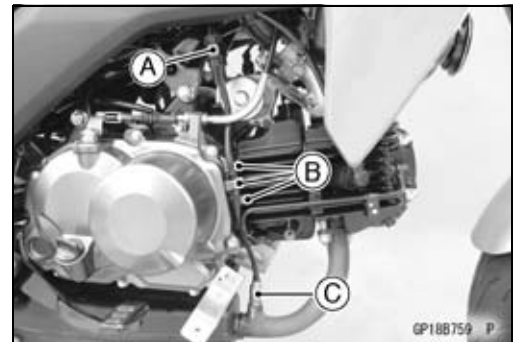

### Oxygen Sensor Installation

#### NOTICE

Never drop the oxygen sensor [A] especially on a hard surface. Such a shock to the unit can damage it. Do not touch the sensing part [B] to prevent oil contact. Oil contamination from hands can reduce sensor performance.

- Tighten:
  - Torque - Oxygen Sensor: 25 N·m (2.5 kgf·m, 18 ft·lb)
- Run the oxygen sensor lead correctly (see Cable, Wire, and Hose Routing section in the Appendix chapter).
- Install the removed parts (see appropriate chapters).

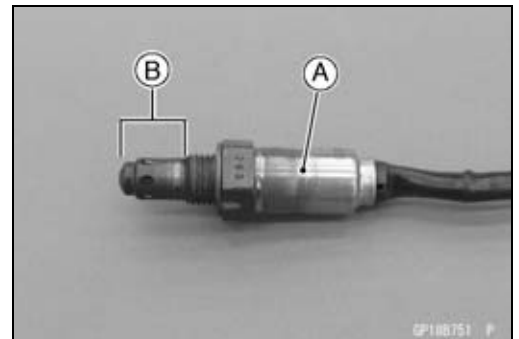

### Oxygen Sensor Inspection

- Refer to the Oxygen Sensor Inspection in the Fuel System (DFI) chapter.

# 15-80 ELECTRICAL SYSTEM

## Switches and Sensors

### Fuel Level Sensor Inspection

- Remove:
  - Fuel Pump (see Fuel Pump Removal in the Fuel System (DFI) chapter)
- Check that the float moves up and down smoothly without binding. It should go down under its own weight.
- ★ If the float does not move smoothly, replace the fuel pump.
  - Float in Full Position [A]
  - Float in Empty Position [B]

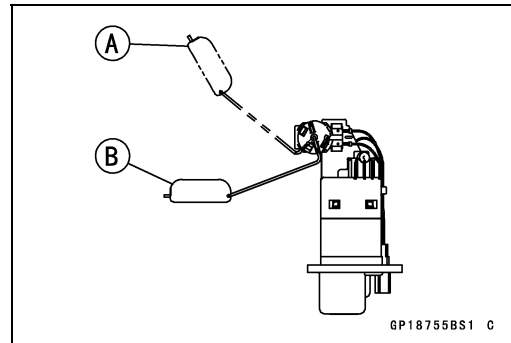

- Using a tester [A] and auxiliary leads, measure the resistance across the terminals [B] in the fuel pump connector [C].
- ★ If the tester readings are not as specified, or do not change smoothly according as the float moves up and down, replace the fuel pump.

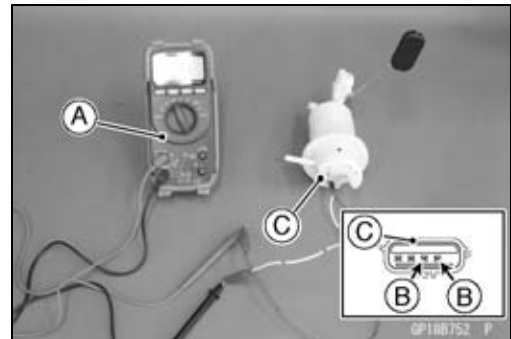

### Fuel Level Sensor Resistance

Standard: Full position: 8.6 ~ 11.4  $\Omega$

Empty position: 246 ~ 254  $\Omega$

### Gear Position Switch Removal

- Remove the engine sprocket cover (see Engine Sprocket Removal in the Final Drive chapter).
- Slide the dust cover [A] and disconnect the gear position switch lead connector [B].
- Remove:
  - Gear Position Switch Mounting Screws [C]
  - Gear Position Switch [D]

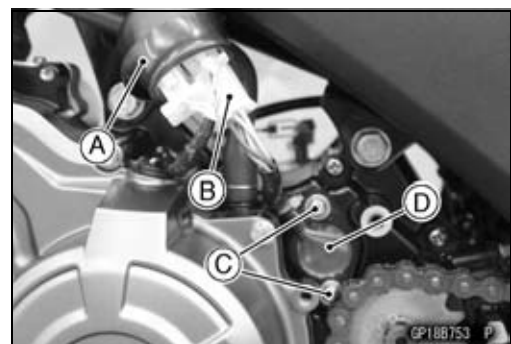

- Remove:
  - Pin [A]
  - Spring [B]

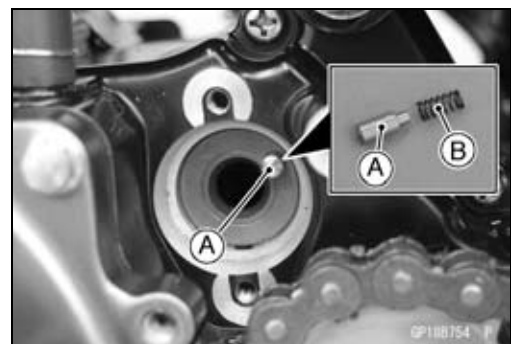

### Gear Position Switch Installation

- Replace the O-ring [A] with a new one.
- Apply grease to the O-ring.
- Check that the pin [B] and spring [C] are in place on the shift drum.
- Install the gear position switch.
- Tighten:

Torque - Gear Position Switch Mounting Screws [D]: 2.9 N·m (0.30 kgf·m, 26 in·lb)

- Install the removed parts (see appropriate chapters).

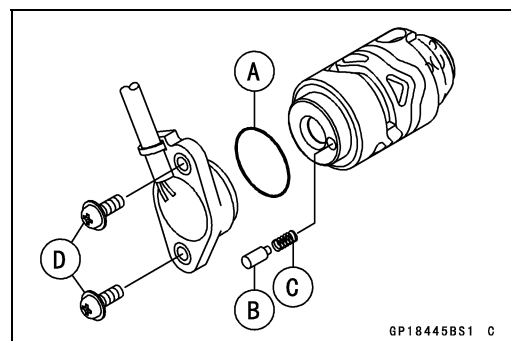



**Switches and Sensors**

***Gear Position Switch Inspection***

- Disconnect the gear position switch lead connector [A].



- Using a digital meter, check to see that only the connections shown in the table have continuity.
- ★ If the switch has an open or short, replace it with a new one.

Color	LB	LG	BL/R	Y/G	G/R	Ground
1	○					○
N		○				○
2			○			○
3				○		○
4					○	○

GP18753BS1 C

# 15-82 ELECTRICAL SYSTEM

## Relay

### Fuel Pump Relay Inspection

- Remove the seat (see Seat Removal in the Frame chapter).
- Remove the fuel pump relay [A] from the bracket [B].

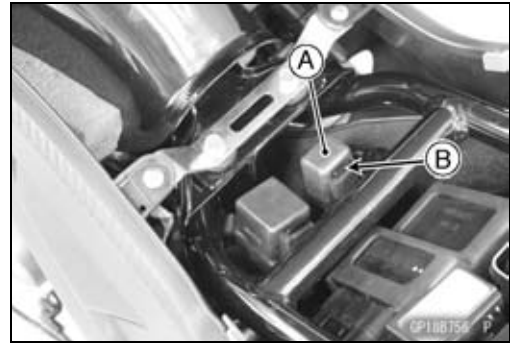

- Slide the dust cover [A] and disconnect the fuel pump relay connector [B].
- Remove the fuel pump relay [C].

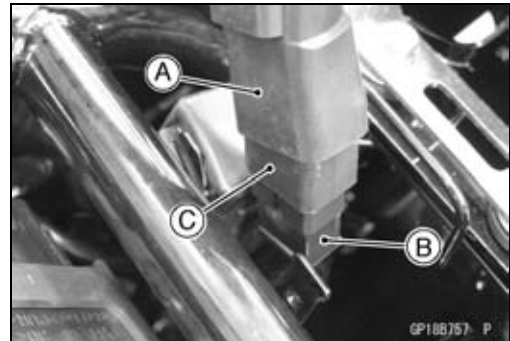

- Connect a tester [A] and 12 V battery [B] to the fuel pump relay [C] as shown.
- ★ If the relay does not work as specified, replace the fuel pump relay.

### Testing Relay

- Criteria:   **When battery is connected** →  $0 \Omega$   
              **When battery is disconnected** →  $\infty \Omega$

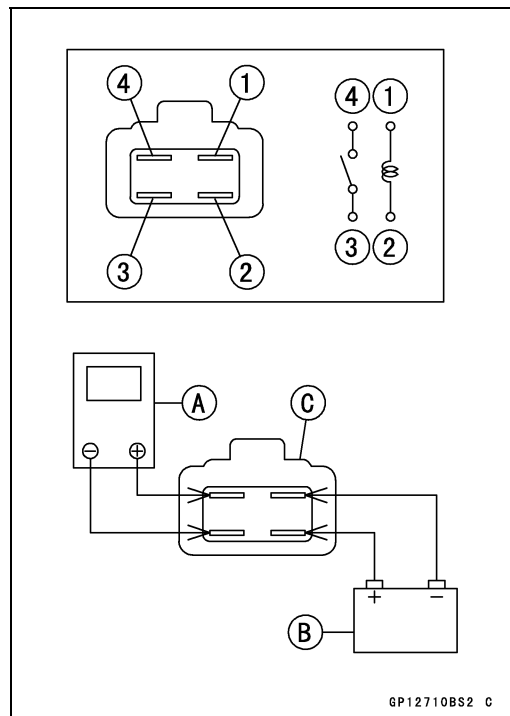

## Fuse

### Fuse Box Fuse Removal

- Remove:  
Seat (see Seat Removal in the Frame chapter)
- Unlock the hook [A] to lift up the lid.



- Pull the fuses [A] straight out of the fuse box with needle nose pliers.



### Fuse Installation

- ★ If a fuse fails during operation, inspect the electrical system to determine the cause, and then replace it with a new fuse of proper amperage.
- Install the fuse box fuses on the original position as specified on the lid.

### Fuse Inspection

- Remove the fuse (see Fuse Box Fuse Removal).
- Inspect the fuse element.
- ★ If it is blown out, replace the fuse. Before replacing a blown fuse, always check the amperage in the affected circuit. If the amperage is equal to or greater than the fuse rating, check the wiring and related components for a short circuit.
  - Housing [A]
  - Fuse Element [B]
  - Terminals [C]
  - Blown Element [D]

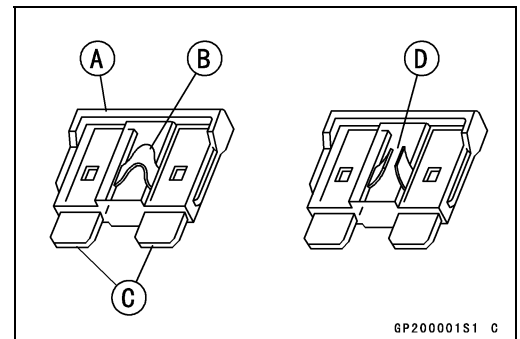

### NOTICE

When replacing a fuse, be sure the new fuse matches the specified fuse rating for that circuit. Installation of a fuse with a higher rating may cause damage to wiring and components.



# Appendix

## Table of Contents

Cable, Wire, and Hose Routing .....	16-2
Troubleshooting Guide .....	16-28

# 16-2 APPENDIX

## Cable, Wire, and Hose Routing

### BR125G/H

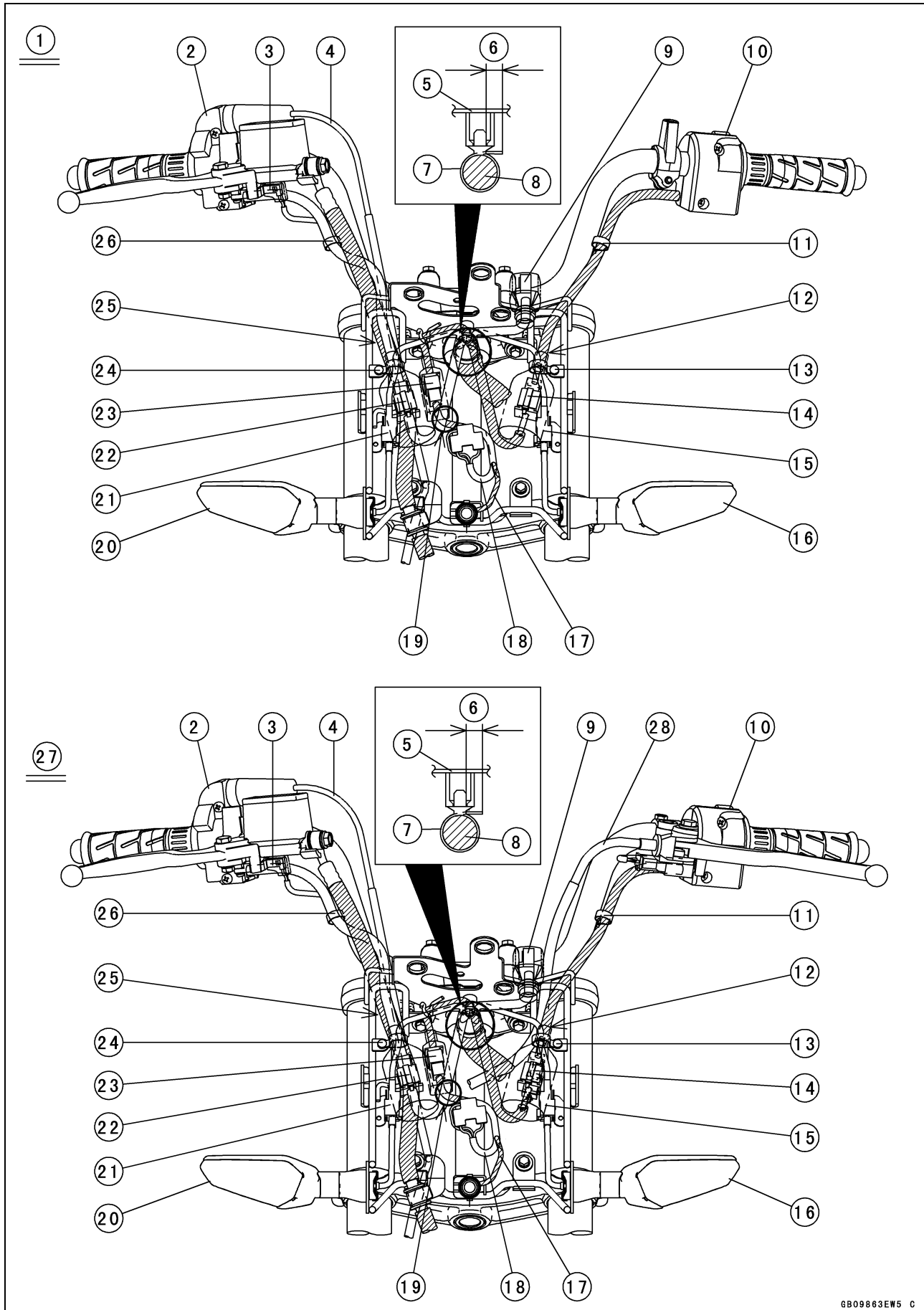

---

**Cable, Wire, and Hose Routing**

---

1. BR125G
2. Right Switch Housing
3. Front Brake Light Switch Lead Connectors
4. Throttle Cable
5. Meter Bracket
6. The length of the protruded band is 2 ~ 4 mm (0.08 ~ 0.16 in.).
7. Band
8. Main Harness
9. Meter Lead Connector
10. Left Switch Housing
11. Clamp (Hold the left switch housing lead.)
12. Run the left switch housing lead in back of the front left turn signal light lead.
13. Clamp (Hold the constricted part of rubber cover and the front left turn signal light lead.)
14. Left Switch Housing Lead Connector with Rubber Cover (Face the rubber cover opening to the bottom.)
15. Front Left Turn Signal Light Lead Connector
16. Front Left Turn Signal Light
17. City Light Lead
18. Headlight Lead
19. Run the headlight lead in back of the right switch housing lead.
20. Front Right Turn Signal Light
21. Front Right Turn Signal Light Lead Connector
22. Right Switch Housing Lead Connector with Rubber Cover (Face the rubber cover opening to the bottom.)
23. Headlight Lead Connector with Rubber Cover (Face the rubber cover opening to the bottom.)
24. Clamp (Hold the front right turn signal light lead and the constricted part of rubber cover.)
25. Run the right switch housing lead in back of the front right turn signal light lead.
26. Clamp (Hold the right switch housing lead.)
27. BR125H
28. Clutch Cable

# 16-4 APPENDIX

## Cable, Wire, and Hose Routing

BR125J

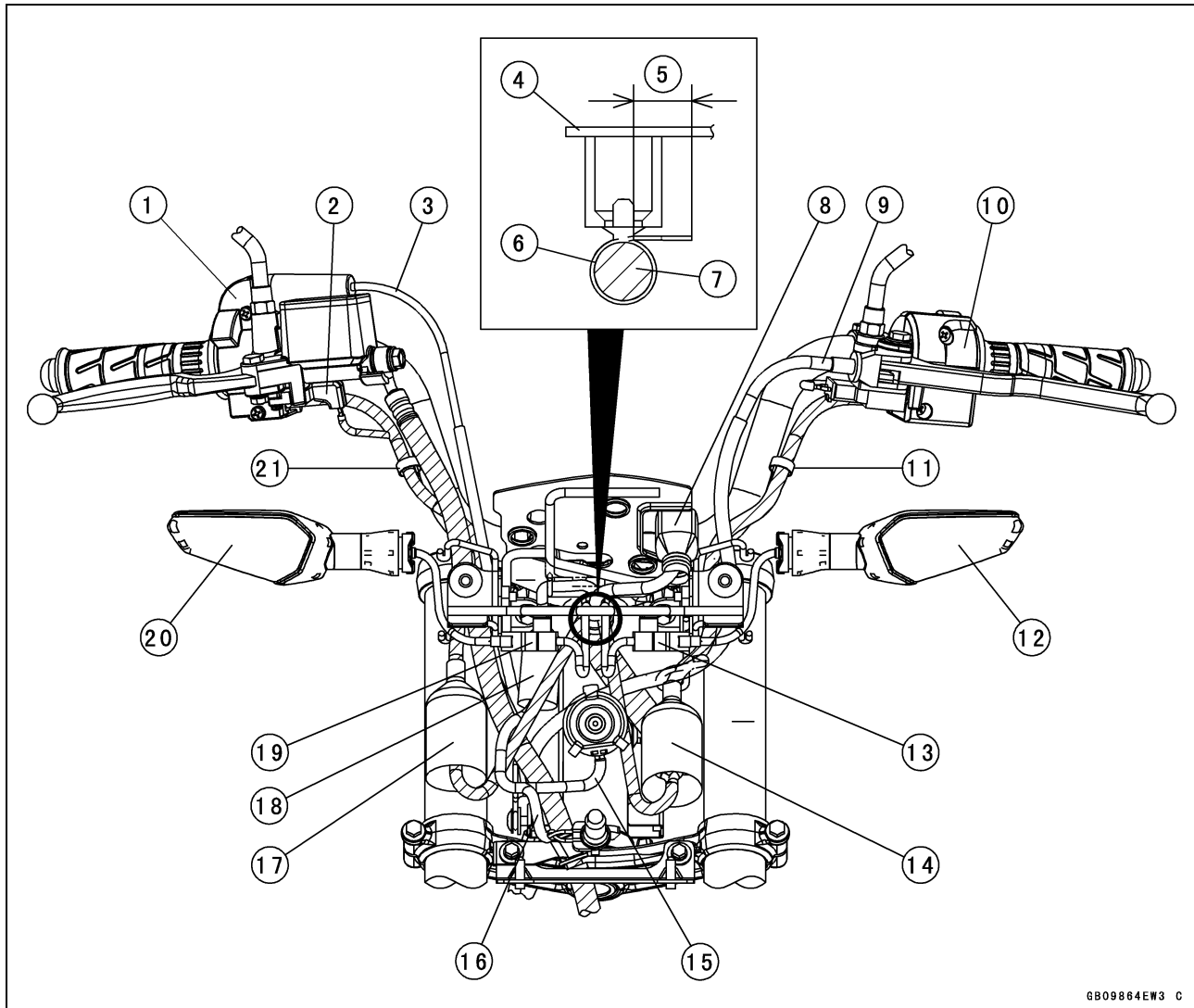



---

**Cable, Wire, and Hose Routing**

---

1. Right Switch Housing
2. Front Brake Light Switch Lead Connectors
3. Throttle Cable
4. Meter Bracket
5. The length of the protruded band is 10 ~ 15 mm (0.39 ~ 0.59 in.).
6. Band
7. Main Harness
8. Meter Lead Connector
9. Clutch Cable
10. Left Switch Housing
11. Clamp (Hold the left switch housing lead.)
12. Front Left Turn Signal Light
13. Front Left Turn Signal Light Lead Connector
14. Left Switch Housing Lead Connector with Rubber Cover (Face the rubber cover opening to the bottom.)
15. Headlight Lead
16. City Light Lead
17. Right Switch Housing Lead Connector with Rubber Cover (Face the rubber cover opening to the bottom.)
18. Headlight Lead Connector with Rubber Cover (Face the rubber cover opening to the bottom.)
19. Front Right Turn Signal Light Lead Connector
20. Front Right Turn Signal Light
21. Clamp (Hold the right switch housing lead.)

# 16-6 APPENDIX

## Cable, Wire, and Hose Routing

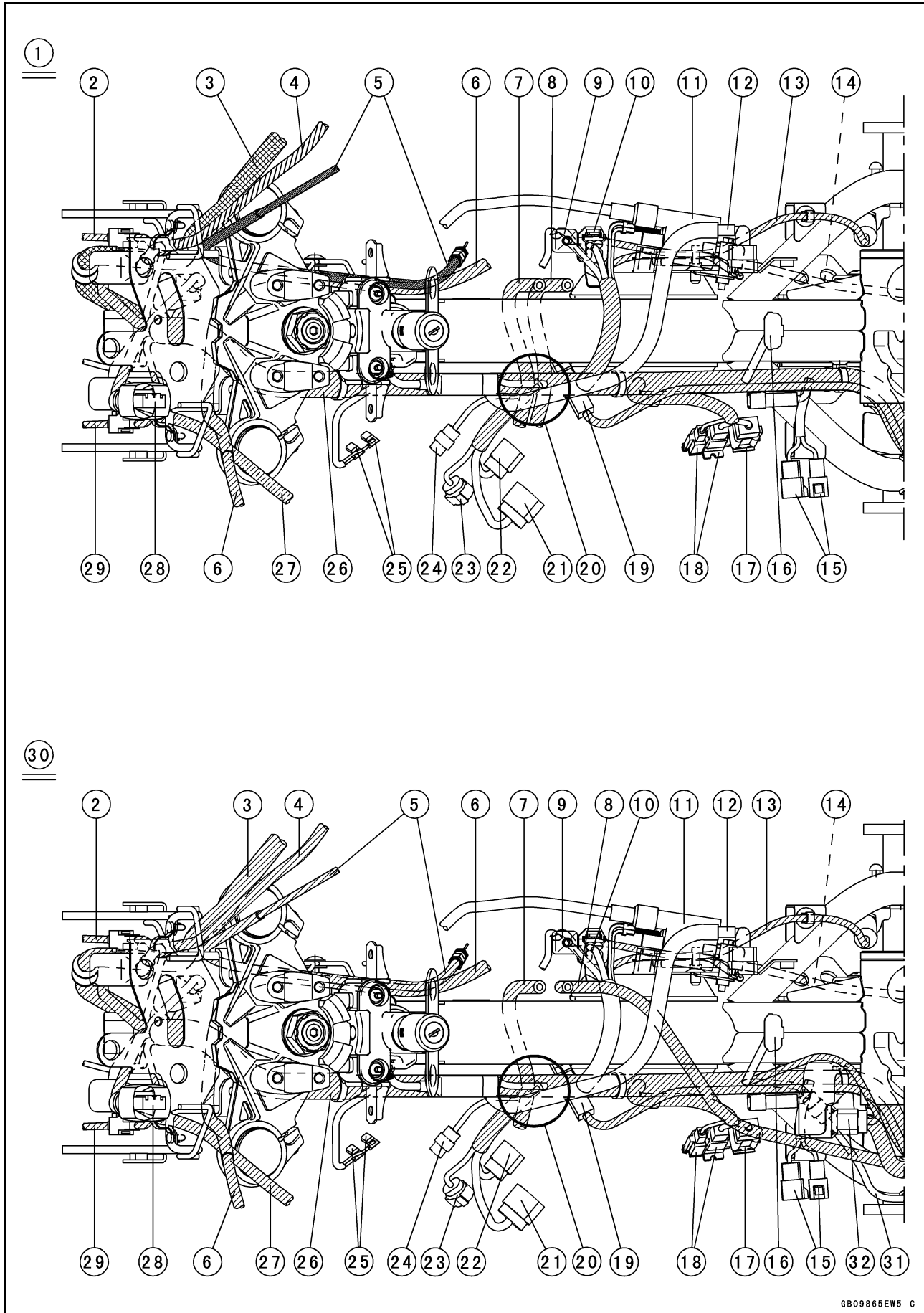

---

**Cable, Wire, and Hose Routing**

---

1. Other than CAL models
2. Front Right Turn Signal Light Lead
3. Front Brake Hose
4. Right Switch Housing Lead
5. Throttle Cable
6. Clutch Cable (BR125H/JI)
7. Fuel Tank Drain Hose
8. Fuel Tank Breather Hose
9. Oxygen Sensor Lead Connector
10. Rear Brake Light Switch Lead Connector
11. Ignition Coil
12. Fuel Hose
13. Rear Brake Light Switch Lead
14. Frame Ground Lead
15. Regulator/Rectifier Connectors
16. Fuel Pump Lead Connector
17. Gear Position Switch Lead Connector
18. Alternator Lead Connectors
19. Starter Motor Cable Connector
20. Do not bend the main harness to outside in this area.
21. Throttle Sensor Lead Connector
22. Intake Air Pressure Sensor Lead Connector
23. Fuel Injector Lead Connector
24. Engine Temperature Sensor Lead Connector
25. Horn Lead Connectors
26. Main Harness
27. Left Switch Housing Lead
28. Meter Lead Connector
29. Front Left Turn Signal Light Lead
30. CAL Model
31. Side Stand Switch Lead
32. Purge Valve Lead Connector

# 16-8 APPENDIX

## Cable, Wire, and Hose Routing

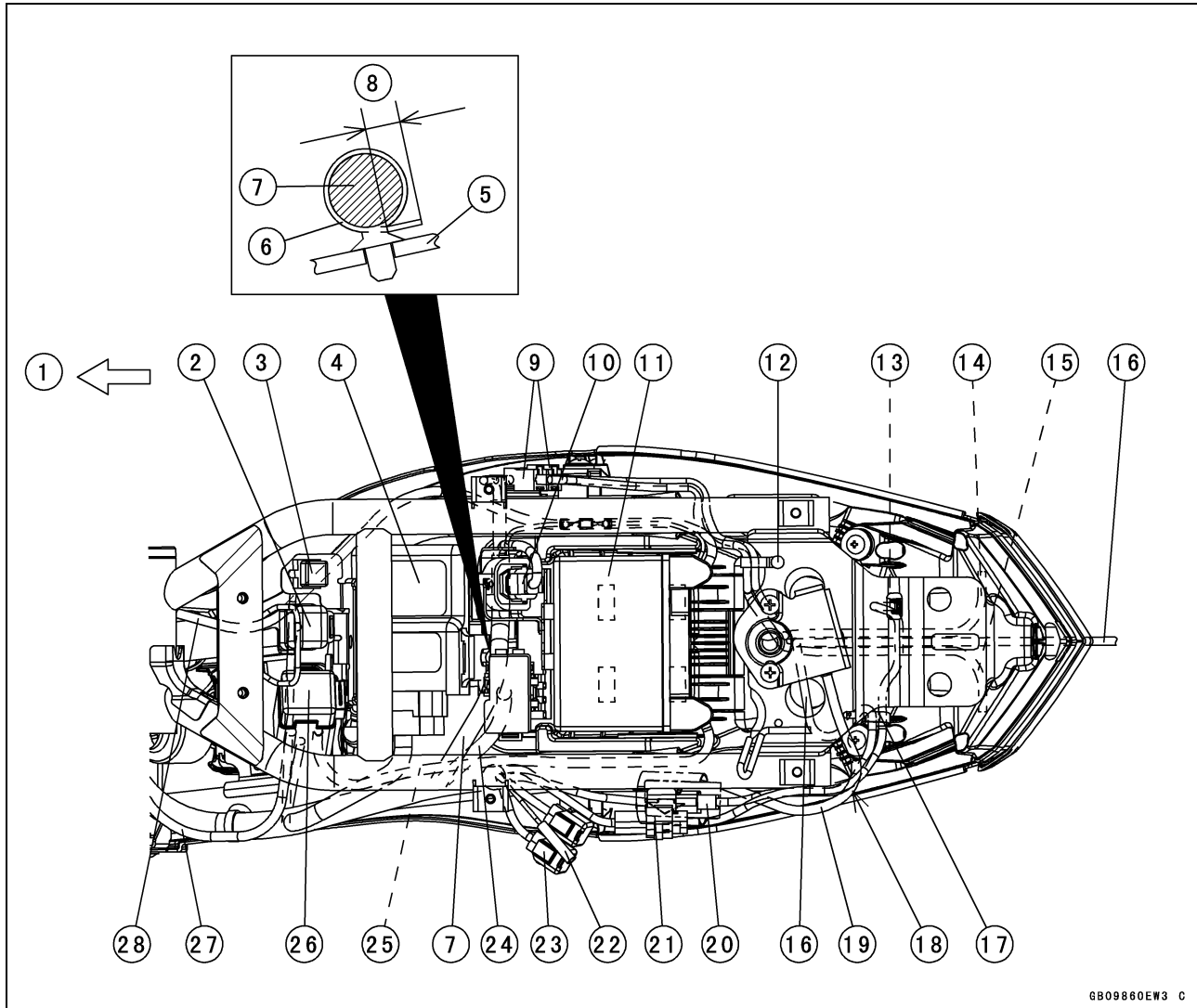

---

**Cable, Wire, and Hose Routing**

---

1. Front
2. Fuel Pump Relay
3. Diode (2) (BR125J)
4. ECU
5. ECU Bracket
6. Band
7. Vehicle-down Sensor Lead
8. The length of the protruded band is 5 ~ 10 mm (0.20 ~ 0.39 in.)
9. Rear Turn Signal Light Lead Connectors
10. Vehicle-down Sensor
11. Battery 12 V 3 Ah
12. Clamp (Hold the rear turn signal light leads.)
13. Tail/Brake Light Lead
14. Rear Right Turn Signal Light Lead
15. Rear Left Turn Signal Light Lead
16. License Plate Light Lead
17. Clamp (Hold the tail/brake light lead and the license plate light lead.)
18. Run the tail/brake light lead and the license plate light lead to inside of the seat lock cable.
19. Seat Lock Cable
20. License Plate Light Lead Connector
21. Tail/Brake Light Lead Connector
22. Self-diagnosis System Terminal
23. Kawasaki Diagnostic System Connector
24. Fuse Box Lead
25. Battery (+) Positive Cable
26. Starter Relay
27. Starter Motor Cable
28. Battery (-) Negative Cable

# 16-10 APPENDIX

## Cable, Wire, and Hose Routing

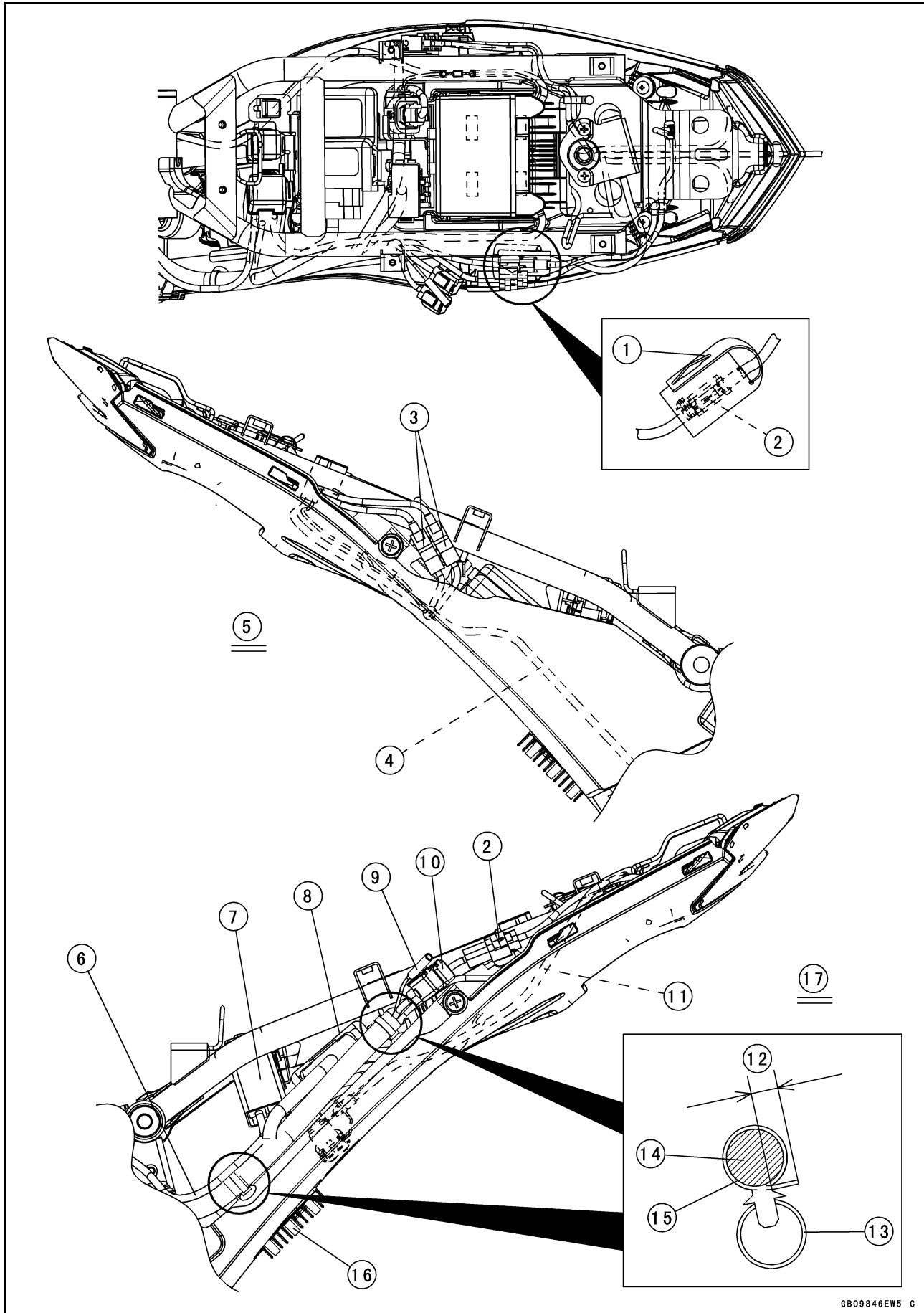

---

**Cable, Wire, and Hose Routing**

---

1. Cover
2. License Plate Light Lead Connector
3. Rear Turn Signal Light Lead Connectors
4. Battery (-) Negative Cable
5. Viewed from Right Side
6. Starter Motor Cable
7. Starter Relay
8. ECU
9. Self-diagnosis System Terminal
10. Kawasaki Diagnostic System Connector
11. Seat Lock Cable
12. The length of the protruded band is 5 ~ 10 mm (0.20 ~ 0.40 in.).
13. Frame
14. Main Harness
15. Band
16. Regulator/Rectifier
17. Viewed from Left Side

# 16-12 APPENDIX

## Cable, Wire, and Hose Routing

BR125G

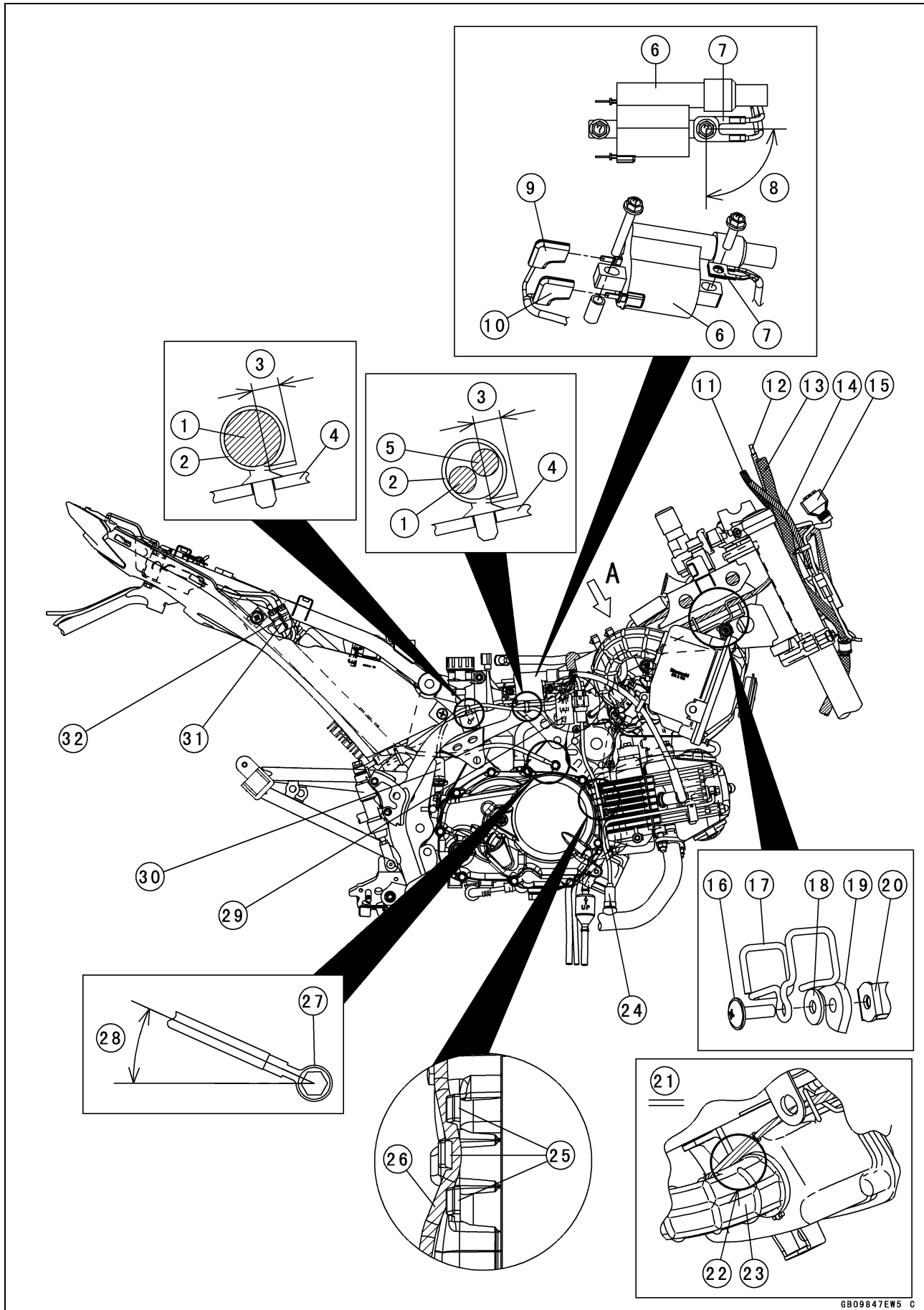



---

**Cable, Wire, and Hose Routing**

---

1. Rear Brake Light Switch Lead
2. Bands
3. The length of the protruded band is 5 ~ 10 mm (0.20 ~ 0.40 in.).
4. Frame
5. Ignition Coil Lead
6. Ignition Coil
7. Frame Ground Terminal
8. 85 ~ 95°
9. Black Terminal
10. Red Terminal
11. Left Switch Housing Lead
12. Throttle Cable
13. Front Brake Hose
14. Right Switch Housing Lead
15. Meter Lead Connector
16. Screw
17. Clamp
18. Washer
19. Air Cleaner Housing
20. Frame
21. Viewed from A
22. Do not touch the throttle cable to the intake duct after the throttle cable installation.
23. Intake Duct
24. Oxygen Sensor
25. Guides of Clutch Cover
26. Oxygen Sensor Lead
27. Engine Ground Terminal
28. 20 ~ 30°
29. Position the rear brake light switch lead connector in rearward of the oxygen sensor lead connector.
30. Rear Brake Light Switch
31. Rear Left Turn Signal Light Lead Connector
32. Rear Right Turn Signal Light Lead Connector

# 16-14 APPENDIX

## Cable, Wire, and Hose Routing

BR125H/J

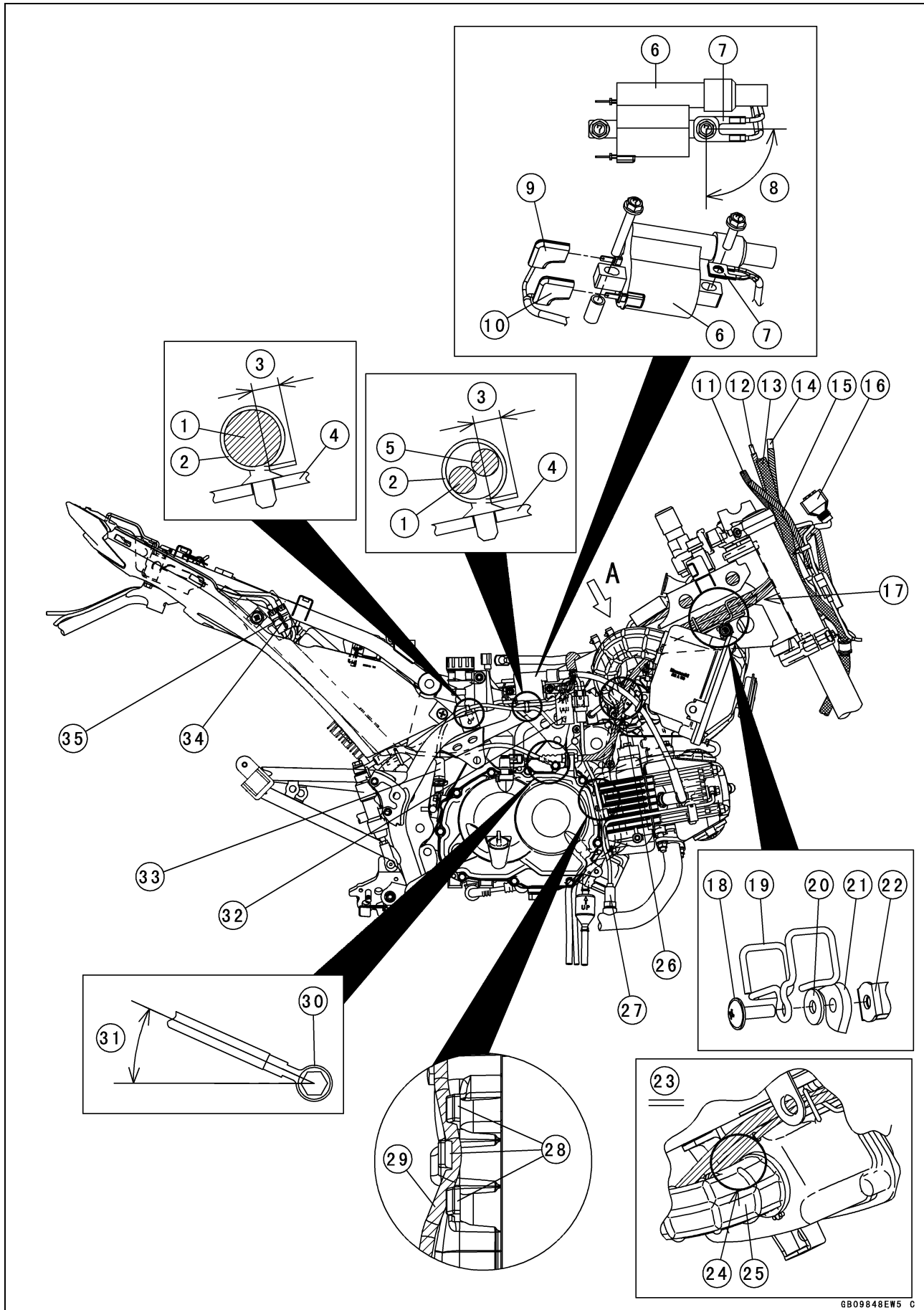

---

**Cable, Wire, and Hose Routing**

---

1. Rear Brake Light Switch Lead
2. Bands
3. The length of the protruded band is 5 ~ 10 mm (0.20 ~ 0.40 in.).
4. Frame
5. Ignition Coil Lead
6. Ignition Coil
7. Frame Ground Terminal
8. 85 ~ 95°
9. Black Terminal
10. Red Terminal
11. Left Switch Housing Lead
12. Throttle Cable
13. Front Brake Hose
14. Clutch Cable
15. Right Switch Housing Lead
16. Meter Lead Connector
17. Run the throttle cable above the clutch cable.
18. Screw
19. Clamp
20. Washer
21. Air Cleaner Housing
22. Frame
23. Viewed from A
24. Do not touch the throttle cable to the intake duct.
25. Intake Duct
26. Do not touch the clutch cable to the intake duct.
27. Oxygen Sensor
28. Guides of Clutch Cover
29. Oxygen Sensor Lead
30. Engine Ground Terminal
31. 20 ~ 30°
32. Position the rear brake light switch lead connector in rearward of the oxygen sensor lead connector.
33. Rear Brake Light Switch
34. Rear Left Turn Signal Light Lead Connector
35. Rear Right Turn Signal Light Lead Connector

# 16-16 APPENDIX

## Cable, Wire, and Hose Routing

BR125G

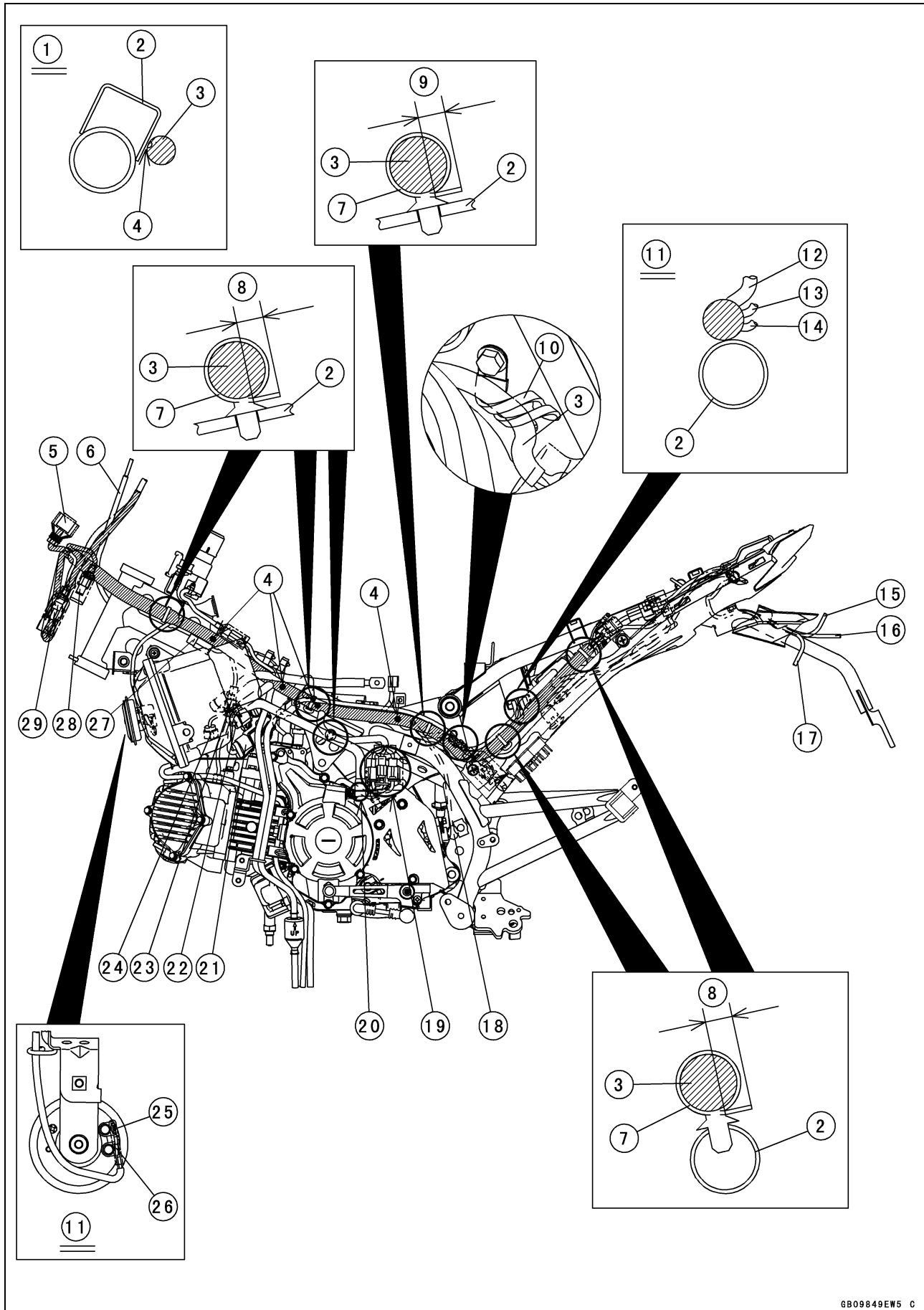

---

**Cable, Wire, and Hose Routing**

---

1. Detail of [4] (Viewed from Front)
2. Frame
3. Main Harness
4. White Marks
5. Meter Lead Connector
6. Throttle Cable
7. Bands
8. The length of the protruded band is 5 ~ 10 mm (0.20 ~ 0.40 in.).
9. The length of the protruded band is 2 ~ 4 mm (0.08 ~ 0.16 in.).
10. Clamp
11. Viewed from Rear
12. ECU Lead
13. Starter Relay Lead
14. Fuel Pump Relay Lead
15. Rear Right Turn Signal Light Lead
16. License Plate Light Lead
17. Rear Left Turn Signal Light Lead
18. Speed Sensor
19. Alternator Lead Connectors and Gear Position Switch Connector with Rubber Cover (Face the rubber cover opening to the bottom.)
20. Run the alternator lead to the inside of the breather hose.
21. Throttle Sensor Lead Connector
22. Idle Speed Control Valve Lead Connector
23. Fuel Injector Lead Connector
24. Engine Temperature Sensor Lead Connector
25. Horn Lead (BR/W)
26. Horn Lead (BK)
27. Diode (1)
28. Headlight Lead Connector
29. Front Left Switch Housing Lead Connector

# 16-18 APPENDIX

## Cable, Wire, and Hose Routing

### BR125H and BR125J (Other than CAL Models)

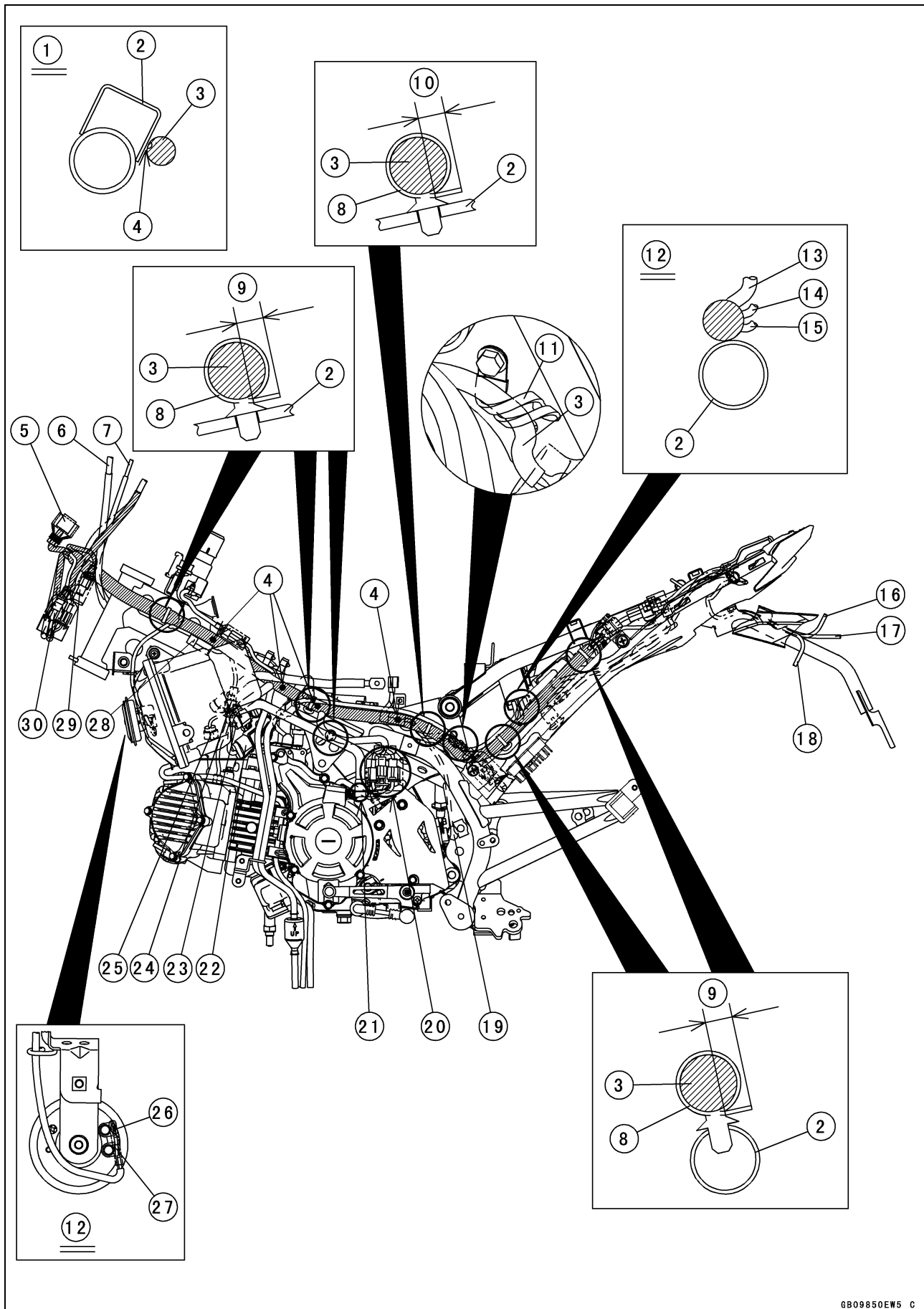

---

**Cable, Wire, and Hose Routing**

---

1. Detail of [4] (Viewed from Front)
2. Frame
3. Main Harness
4. White Marks
5. Meter Lead Connector
6. Clutch Cable
7. Throttle Cable
8. Bands
9. The length of the protruded band is 5 ~ 10 mm (0.20 ~ 0.40 in.).
10. The length of the protruded band is 2 ~ 4 mm (0.08 ~ 0.16 in.).
11. Clamp
12. Viewed from Rear
13. ECU Lead
14. Starter Relay Lead
15. Fuel Pump Relay Lead
16. Rear Right Turn Signal Light Lead
17. License Plate Light Lead
18. Rear Left Turn Signal Light Lead
19. Speed Sensor
20. Alternator Lead Connectors and Gear Position Switch Connector with Rubber Cover (Face the rubber cover opening to the bottom.)
21. Run the alternator lead to the inside of the breather hose.
22. Throttle Sensor Lead Connector
23. Idle Speed Control Valve Lead Connector
24. Fuel Injector Lead Connector
25. Engine Temperature Sensor Lead Connector
26. Horn Lead (BR/W)
27. Horn Lead (BK)
28. Diode (1)
29. Headlight Lead Connector
30. Front Left Switch Housing Lead Connector

# 16-20 APPENDIX

## Cable, Wire, and Hose Routing

### BR125J (CAL Model)

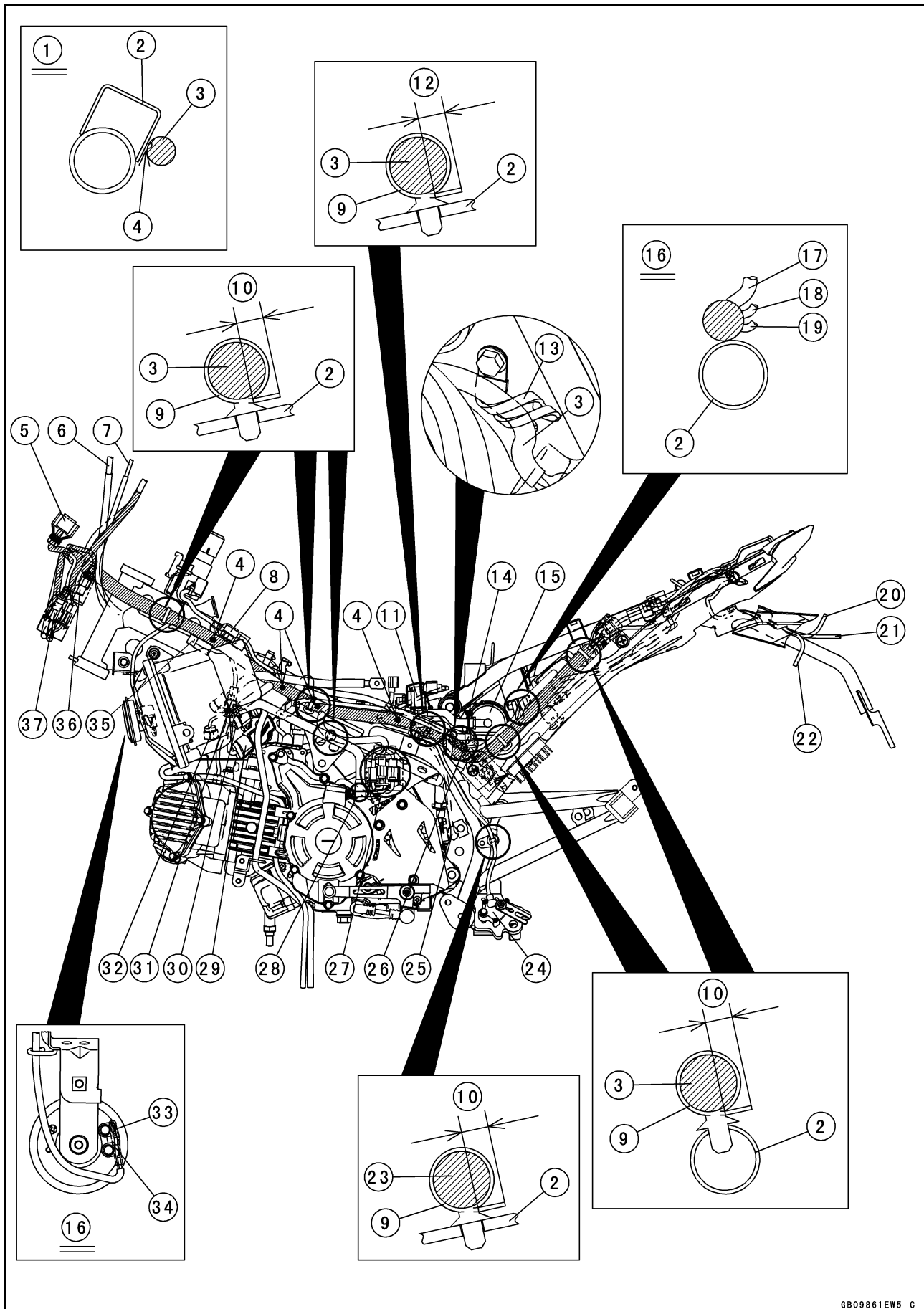



---

**Cable, Wire, and Hose Routing**

---

1. Detail of [4] (Viewed from Front)
2. Frame
3. Main Harness
4. White Marks
5. Meter Lead Connector
6. Clutch Cable
7. Throttle Cable
8. Ignition Switch Lead Connector
9. Bands
10. The length of the protruded band is 5 ~ 10 mm (0.20 ~ 0.40 in.).
11. Purge Valve
12. The length of the protruded band is 2 ~ 4 mm (0.08 ~ 0.16 in.).
13. Clamp
14. Clamp (Face the knob of the clamp upward.)
15. Canister
16. Viewed from Rear
17. ECU Lead
18. Starter Relay Lead
19. Fuel Pump Relay Lead
20. Rear Right Turn Signal Light Lead
21. License Plate Light Lead
22. Rear Left Turn Signal Light Lead
23. Side Stand Switch Lead
24. Side Stand Switch
25. Speed Sensor
26. Clamp (Face the knob of the clamp downward.)
27. Alternator Lead Connectors and Gear Position Switch Connector with Rubber Cover (Face the rubber cover opening to the bottom.)
28. Run the alternator lead to the inside of the breather hose.
29. Throttle Sensor Lead Connector
30. Idle Speed Control Valve Lead Connector
31. Fuel Injector Lead Connector
32. Engine Temperature Sensor Lead Connector
33. Horn Lead (BR/W)
34. Horn Lead (BK)
35. Diode (1)
36. Headlight Lead Connector
37. Front Left Switch Housing Lead Connector

# 16-22 APPENDIX

## Cable, Wire, and Hose Routing

### Other than CAL Models

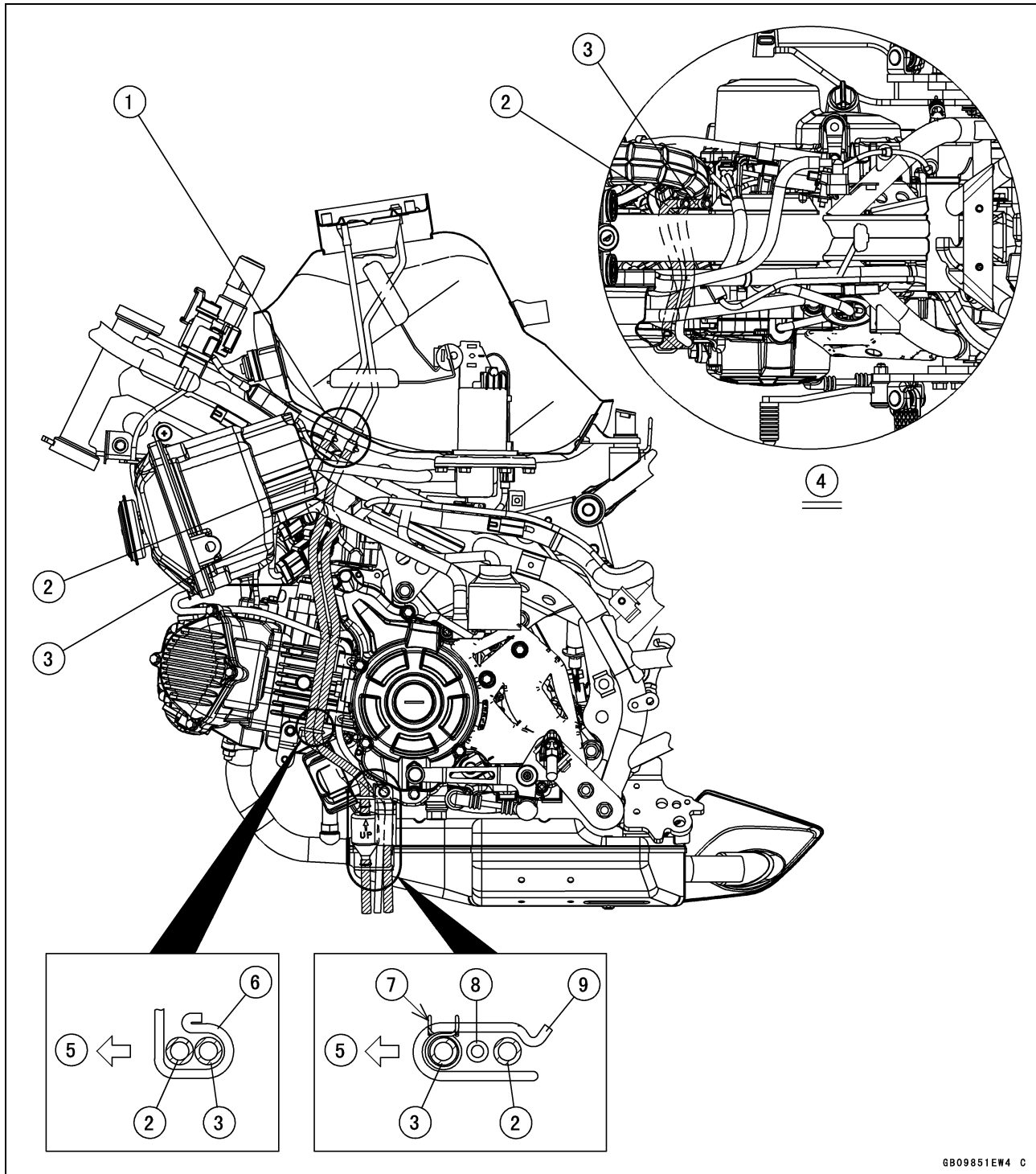

GB09851EW4 C

1. Face the knob of the clamps rearward.
2. Fuel Tank Drain Hose
3. Fuel Tank Breather Hose
4. Viewed from Top
5. Front
6. Clamp
7. Face the knob of the clamp inward.
8. Air Cleaner Housing Breather Hose
9. Clamp

## Cable, Wire, and Hose Routing

## CAL Model

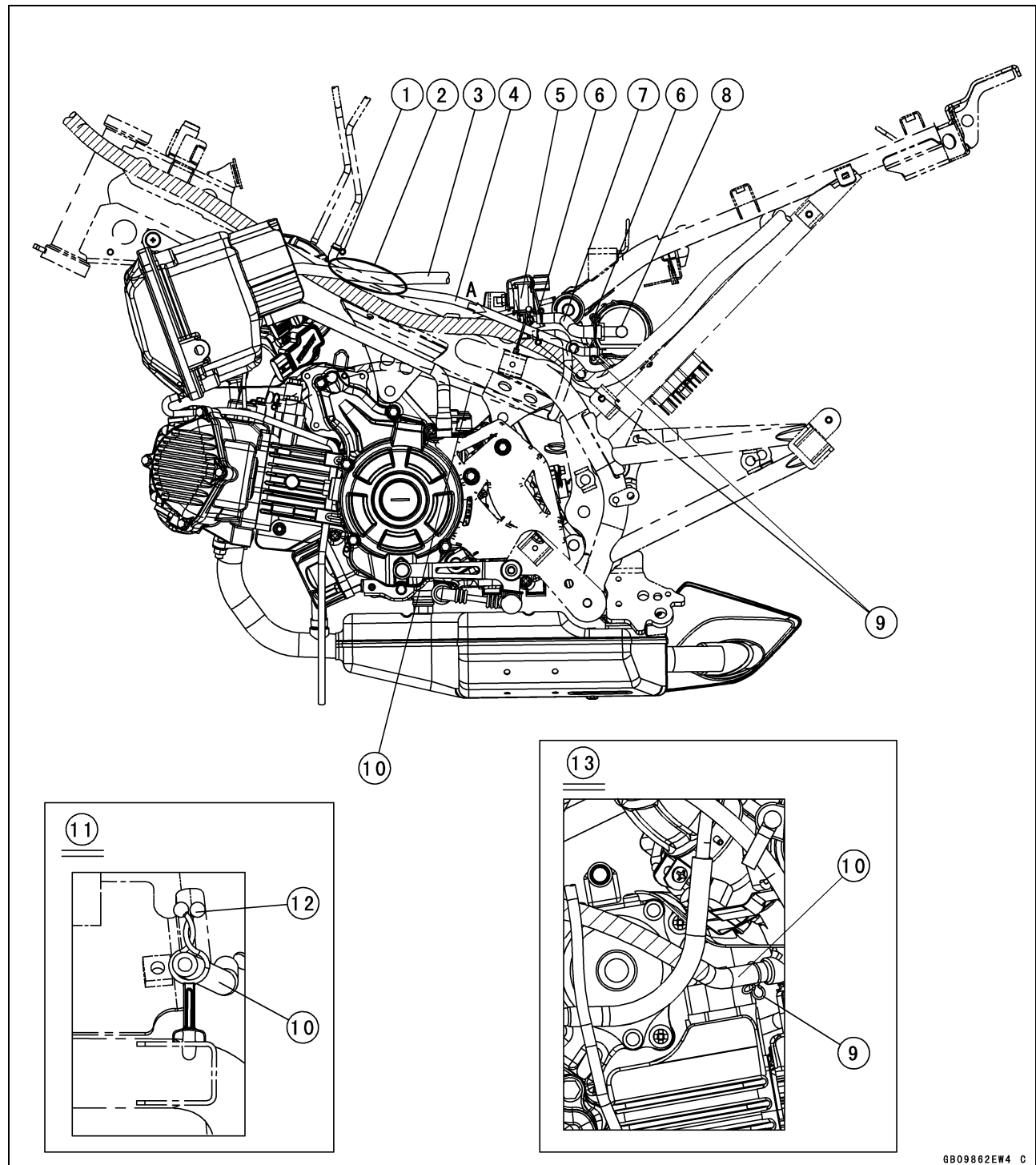

GB09862EW4 C

1. Face the knob of the clamp rearward.
2. Run the fuel hose to the inside of the breather hose.
3. Fuel Hose
4. Breather Hose
5. Purge Valve
6. Face the knob of the clamp upward.
7. Breather Hose
8. Canister
9. Face the knob of the clamp downward.
10. Purge Valve Hose
11. Viewed from A
12. Clamp
13. Viewed from Right

## 16-24 APPENDIX

### Cable, Wire, and Hose Routing

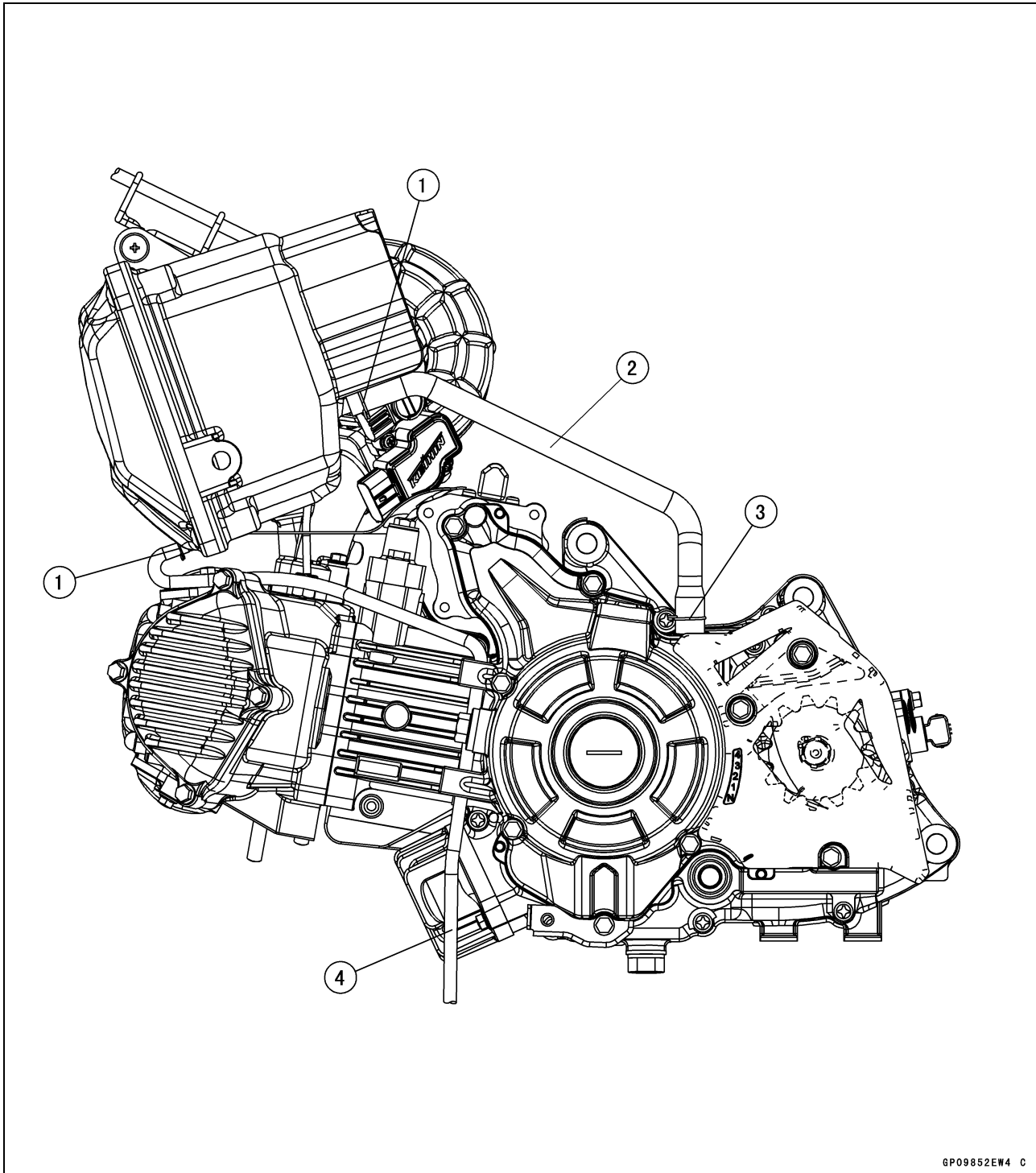

1. Clamps (Face the knob of the clamp downward.)
2. Breather Hose
3. Clamp (Face the knob of the clamp forward.)
4. Air Cleaner Housing Drain Hose

## Cable, Wire, and Hose Routing

## BR125G/H

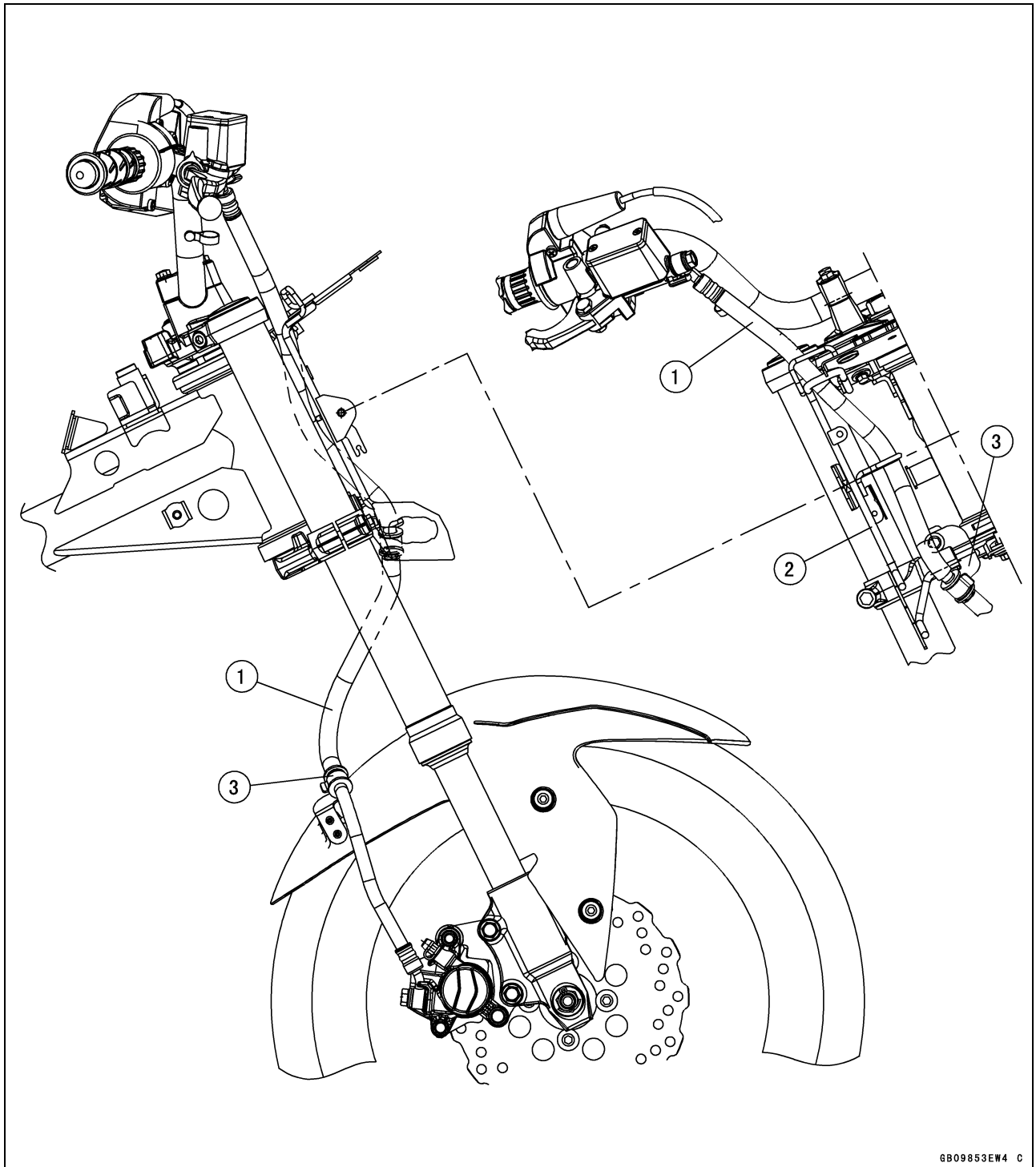

GB09853EW4 C

1. Brake Hose
2. Meter Bracket
3. Clamps (Hold the brake hose.)

# 16-26 APPENDIX

## Cable, Wire, and Hose Routing

BR125J

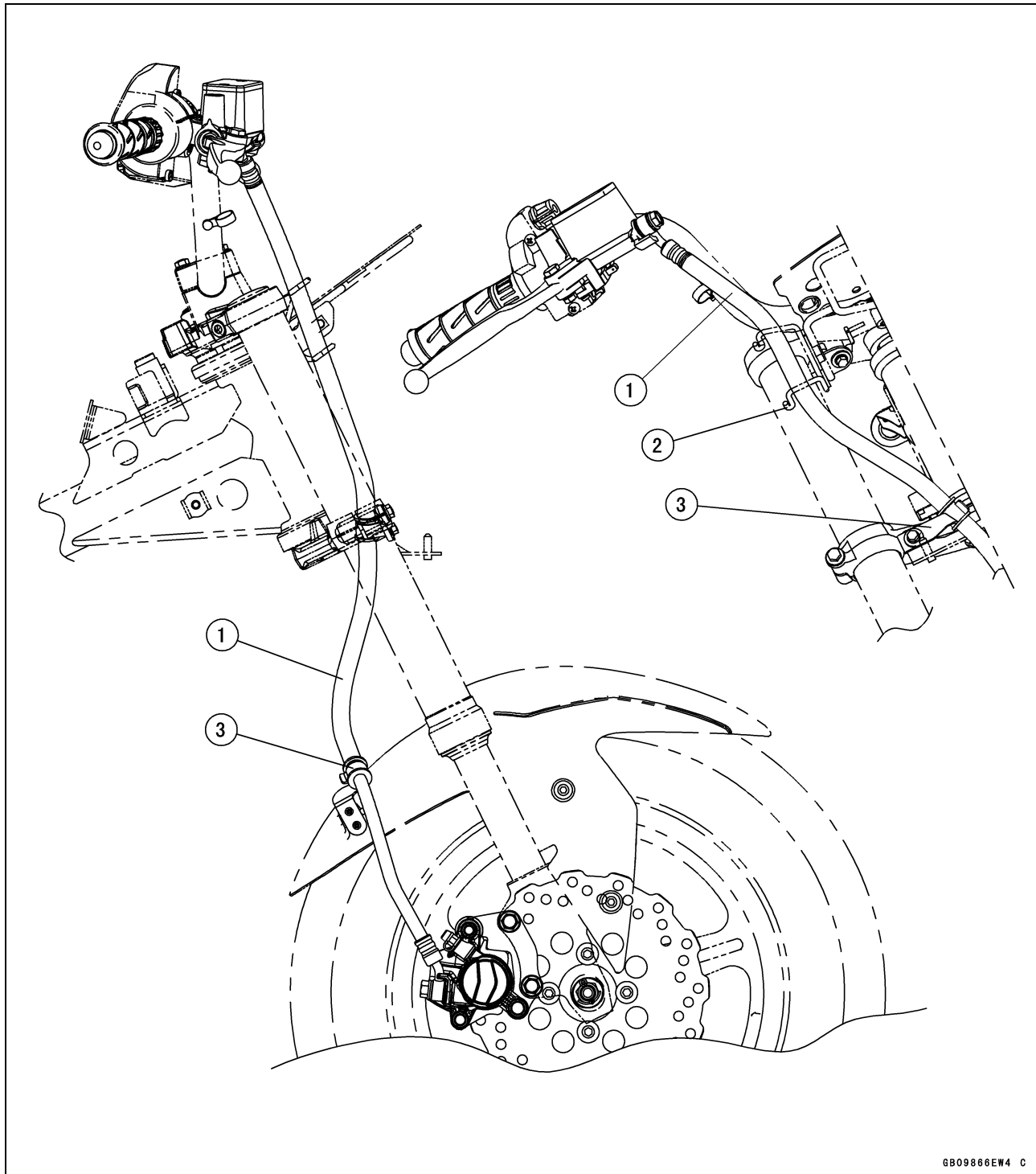

GB09866EW4 C

- 1. Brake Hose
- 2. Meter Bracket
- 3. Clamps (Hold the brake hose.)

## Cable, Wire, and Hose Routing

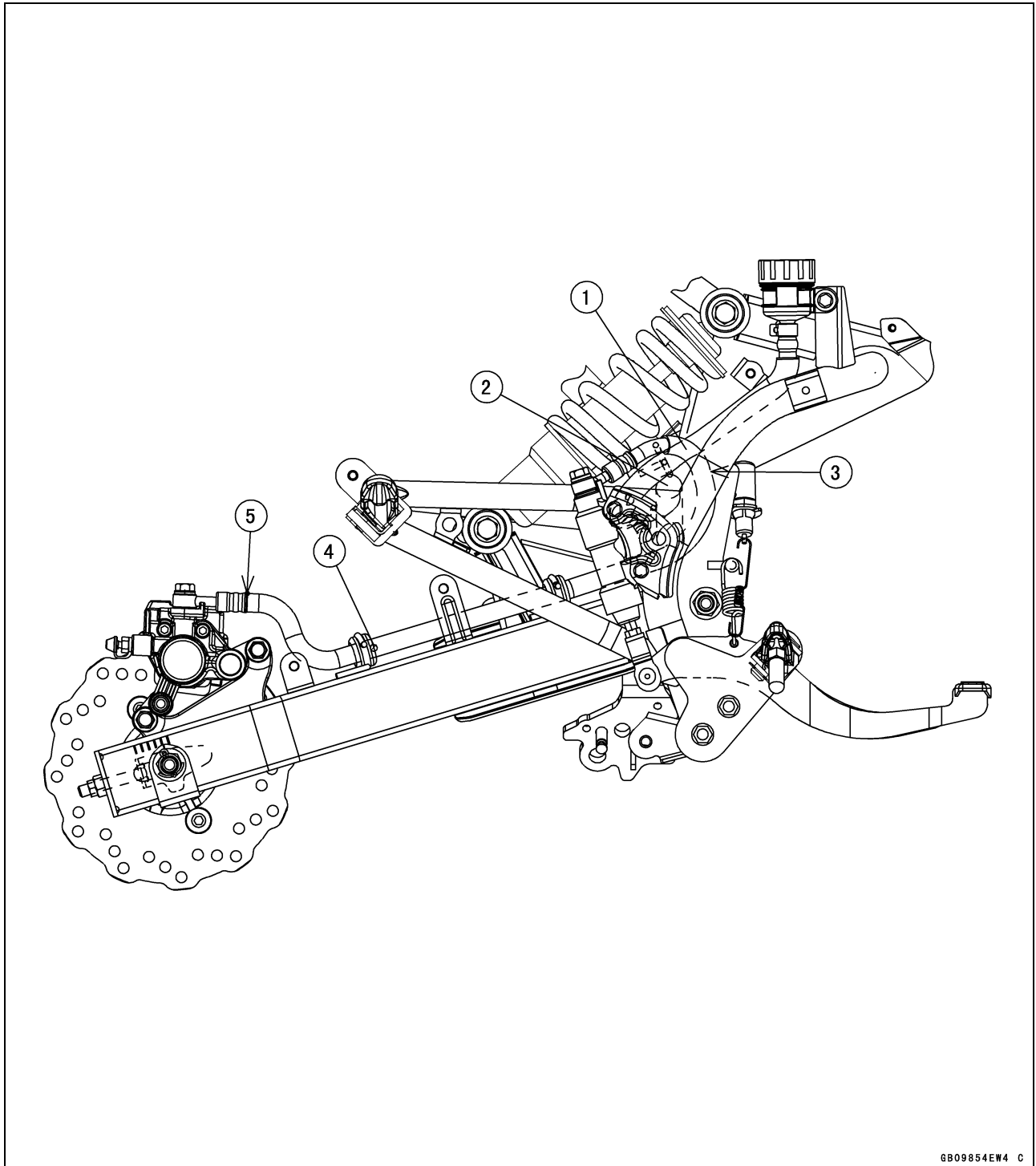

1. Brake Hose
2. Frame Pipe
3. Run the brake hose in front of the frame pipe.
4. Align the white mark of the brake hose to edge of the clamp.
5. Install the brake hose protector tube so that it reaches to the end of rear fitting.

## Troubleshooting Guide

---

### NOTE

- Refer to the *Fuel System (DFI)* chapter for most of DFI trouble shooting guide.
- This is not an exhaustive list, giving every possible cause for each problem listed. It is meant simply as a rough guide to assist the troubleshooting for some of the more common difficulties.

### Engine Doesn't Start, Starting Difficulty:

#### Starter motor not rotating:

- Starter lockout switch trouble (BR125H/J)
- Gear position switch trouble
- Starter motor defective
- Battery voltage low
- Relay not contacting or operating
- Starter button not contacting
- Wiring open or shorted
- Ignition switch defective
- Engine stop switch defective
- Engine stop switch off
- Fuse blown

#### Starter motor rotating but engine doesn't turn over:

- Starter motor clutch defective
- Vehicle-down sensor (DFI) coming off

#### Engine won't turn over:

- Valve seizure
- Cylinder, piston seizure
- Crankshaft seizure
- Connecting rod small end seizure
- Connecting rod big end seizure
- Camshaft seizure
- Transmission gear or crankcase bearing seizure

#### No fuel flow:

- No fuel in tank
- Fuel tank air vent obstructed
- Fuel pump trouble
- Fuel line clogged
- Fuel filter clogged

#### Engine flooded:

- Clean spark plug and adjust plug gap
- Starting technique faulty  
(When flooded, do not crank the engine with the throttle fully opened. This promotes engine flood because more fuel is supplied automatically by DFI.)

#### No spark, spark weak:

- Vehicle-down sensor (DFI) coming off
- Ignition switch not on
- Engine stop switch turned off
- Clutch lever not pulled in or gear not in neutral (BR125H/J)
- Battery voltage low
- Spark plug dirty, damaged or maladjusted

Spark plug cap or high tension lead damaged

Spark plug cap shorted or not in good contact

Spark plug incorrect

Ignition coil damaged

IC igniter in ECU trouble

Alternator rotor damaged

Starter lockout switch trouble (BR125H/J)

Gear position switch trouble

Crankshaft sensor trouble

Ignition switch or engine stop switch shorted

Wiring shorted or open

Fuse brown

#### Fuel/air mixture incorrect:

Air cleaner clogged, poorly sealed or missing

#### Compression Low:

Cylinder, piston worn

Piston ring bad (worn, weak, broken, or sticking)

Piston ring/groove clearance excessive

Cylinder head gasket damaged

Cylinder head not sufficiently tightened down

Cylinder head warped

Spark plug loose

No valve clearance

Valve spring broken or weak

Valve not seating properly (valve bent, worn or carbon accumulation on the seating surface)

#### Poor Running at Low Speed:

##### Spark weak:

Spark plug dirty, damaged, or maladjusted

Spark plug cap or high tension lead damaged

Spark plug cap shorted or not in good contact

Spark plug incorrect

Crankshaft sensor trouble

Ignition coil damaged

IC igniter in ECU trouble

Alternator rotor damaged

##### Fuel/air mixture incorrect:

Air cleaner clogged, poorly sealed, or missing

Air cleaner duct loose

Fuel tank air vent obstructed

Fuel pump trouble

Intake pipe loose

##### Compression low:

Cylinder, Piston worn

Piston rings bad (worn, weak, broken or sticking)

Piston ring/groove clearance excessive



## Troubleshooting Guide

Cylinder head gasket damaged  
 Cylinder head not sufficiently tightened down  
 Cylinder head warped  
 No valve clearance  
 Spark plug loose  
 Valve spring broken or weak  
 Valve not seating properly (valve bent, worn, or carbon accumulation on the seating surface)  
 Crankshaft oil seal deteriorated or damaged

### Other:

IC igniter in ECU trouble  
 Engine oil viscosity too high  
 Drive train trouble  
 Brake dragging  
 Engine overheating  
 Clutch slipping

### Poor Running or No Power at High Speed:

#### Firing incorrect:

Spark plug dirty, damaged, or maladjusted  
 Spark plug cap or high tension lead damaged  
 Spark plug cap shorted or not in good contact  
 Spark plug incorrect  
 Ignition coil trouble  
 Crankshaft sensor trouble  
 IC igniter in ECU trouble

#### Fuel/air mixture incorrect:

Air cleaner clogged, poorly sealed or missing  
 Intake pipe loose  
 Fuel to injector insufficient (DFI)  
 Water or foreign matter in fuel  
 Fuel tank air vent obstructed  
 Fuel line clogged  
 Fuel pump trouble  
 Air cleaner duct loose

#### Compression low:

Cylinder, piston worn  
 Piston rings bad (worn, weak, broken, or sticking)  
 Piston ring/groove clearance excessive  
 Cylinder head gasket damaged  
 Cylinder head not sufficiently tightened down  
 Cylinder head warped  
 No valve clearance  
 Spark plug loose  
 Valve not seating properly (valve bent, worn or carbon accumulation on the seating surface)  
 Valve spring broken or weak

#### Knocking:

Carbon built up in combustion chamber

Fuel poor quality or incorrect  
 Spark plug incorrect  
 IC igniter in ECU trouble  
 Crankshaft sensor trouble

### Miscellaneous:

Throttle valve does not fully open  
 Air cleaner clogged  
 Brake dragging  
 Clutch slipping  
 Engine overheating  
 Engine oil level too high  
 Engine oil viscosity too high  
 Crankshaft bearing worn or damaged  
 Drive train trouble  
 Catalytic converter melt down due to muffler overheating

### Overheating:

#### Firing incorrect:

Spark plug dirty, broken, or maladjusted  
 Spark plug incorrect  
 IC igniter in ECU trouble

#### Muffler overheating:

For catalytic converter, do not push-start with a dead battery (Connect another full-charged battery with jumper cables, and start the engine using the electric starter.).  
 For catalytic converter, do not start the engine under misfire due to spark plug fouling or poor connection of the spark plug.  
 IC igniter in ECU trouble

#### Fuel/air mixture incorrect:

Intake pipe loose  
 Air cleaner clogged  
 Air cleaner poorly sealed, or missing  
 Air cleaner duct loose

#### Compression high:

Carbon built up in combustion chamber

#### Engine load faulty:

Clutch slipping  
 Engine oil level too high  
 Engine oil viscosity too high  
 Brake dragging  
 Drive train trouble

#### Lubrication inadequate:

Engine oil level too low  
 Engine oil poor quality or incorrect

### Clutch Operation Faulty:

#### Clutch slipping:

No clutch release play (BR125G)  
 No clutch lever play (BR125H/J)  
 Clutch cable maladjusted (BR125H/J)  
 Clutch inner cable sticking (BR125H/J)  
 Friction plate worn or warped  
 Steel plate worn or warped  
 Clutch spring broken or weak  
 Clutch release maladjusted (BR125G)  
 Clutch release mechanism trouble

## 16-30 APPENDIX

### Troubleshooting Guide

---

Clutch hub or housing unevenly worn

#### **Clutch not disengaging properly:**

Clutch release play excessive (BR125G)

Clutch lever play excessive (BR125H/J)

Clutch plate warped or too rough

Clutch spring compression uneven

Engine oil deteriorated

Engine oil level too high

Engine oil viscosity too high

Clutch housing frozen on drive shaft

Clutch release mechanism trouble

Clutch hub nut loose

Clutch hub spline damaged

Clutch friction plate installed wrong

#### **Gear Shifting Faulty:**

##### **Doesn't go into gear; shift pedal doesn't return:**

Clutch not disengaging

Shift fork bent or seized

Gear stuck on the shaft

Shift return spring weak or broken

Shift pawl spring broken

Shift return spring pin loose

Gear set lever binding on pivot bolt

External shift mechanical arm worn

Shift drum damaged

##### **Jumps out of gear:**

Shift fork worn, bent

Gear groove worn

Gear dogs, holes, and/or recesses worn

Shift drum groove worn

Shift drum positioning lever spring weak or broken

Shift fork guide pin worn

Shift pawl spring weak or broken

Drive shaft, output shaft, and/or gear splines worn

##### **Overshifts:**

Shift drum positioning lever spring weak or broken

Shift pawl spring weak or broken

#### **Abnormal Engine Noise:**

##### **Knocking:**

IC igniter in ECU trouble

Carbon built up in combustion chamber

Fuel poor quality or incorrect

Overheating

Spark plug incorrect

##### **Piston slap:**

Cylinder/piston clearance excessive

Cylinder, piston worn

Connecting rod bent

Piston pin, piston holes worn

##### **Valve noise:**

Valve clearance incorrect

Valve spring broken or weak

Camshaft journals worn

##### **Other noise:**

Connecting rod small end clearance excessive

Connecting rod big end clearance excessive

Piston ring worn, broken, or stuck

Piston seizure or damaged

Cylinder head gasket leaking

Exhaust pipe leaking at cylinder head connection

Crankshaft runout excessive

Engine mounts loose

Crankshaft bearing worn

Camshaft chain tensioner trouble

Camshaft chain, sprocket and/or guide worn

Alternator rotor loosened

Piston ring groove worn

Catalytic converter melt down due to muffler overheating

#### **Abnormal Drive Train Noise:**

##### **Clutch noise:**

Clutch housing or hub damaged

Clutch housing/friction plate clearance excessive

Clutch housing gear/primary gear backlash excessive

##### **Transmission noise:**

Crankcase bearing worn

Metal chip jammed in gear teeth

Transmission gears worn or chipped

Engine oil insufficient or too thin

##### **Drive line noise:**

Drive chain adjusted improperly

Drive chain worn

Rear and/or engine sprocket(s) worn

Chain lubrication insufficient

Rear Wheel misaligned

#### **Abnormal Frame Noise:**

##### **Front fork noise:**

Oil insufficient or too thin

Spring weak or broken

##### **Rear shock absorber noise:**

Shock absorber damaged

##### **Brake noise:**

Pad surface glazed

Disc warped

Caliper trouble

Pad installed incorrectly

##### **Other noise:**

Bracket, nut, bolt, etc. not properly mounted or tightened

#### **Exhaust Smokes Excessively:**

##### **White smoke:**

Piston oil ring worn

Cylinder worn

Valve oil seal damaged

## Troubleshooting Guide

---

Valve guide worn  
 Engine oil level too high

### **Black smoke:**

Air cleaner clogged

### **Brown smoke:**

Air cleaner duct loose  
 Air cleaner poorly sealed or missing  
 Air cleaner clogged

### **Handling and/or Stability Unsatisfactory:**

#### **Handlebar hard to turn:**

Cable routing incorrect  
 Hose routing incorrect  
 Wiring routing incorrect  
 Steering stem nut too tight  
 Steering stem bearing damaged  
 Race(s) dented or worn  
 Steering stem bearing lubrication inadequate  
 Steering stem bent  
 Tire air pressure too low

#### **Handlebar shakes or excessively vibrates:**

Tire worn  
 Swingarm bushing damaged  
 Rim warped  
 Front, rear axle runout excessive  
 Wheel bearing worn  
 Handlebar clamp bolt loose  
 Steering stem head nut loose  
 Engine mounts loose

#### **Handlebar pulls to one side:**

Frame bent  
 Wheel misalignment  
 Swingarm bent or twisted  
 Swingarm pivot shaft runout excessive  
 Steering stem bent  
 Front fork leg bent  
 Right/left front fork oil level uneven  
 Rear shock absorber bent

#### **Shock absorption unsatisfactory:**

(Too hard)

Front fork oil excessive  
 Front fork oil viscosity too high  
 Front fork bent  
 Tire air pressure too high  
 (Too soft)  
 Front fork oil viscosity too low  
 Front fork, rear shock absorber spring(s) weak  
 Front fork oil leaking  
 Rear shock absorber oil leaking  
 Tire air pressure too low

### **Brake Doesn't Hold:**

Air in the brake line  
 Pad or disc worn  
 Brake fluid leakage  
 Disc warped  
 Contaminated pad  
 Brake fluid deteriorated  
 Primary or secondary cup damaged in master cylinder  
 Master cylinder scratched inside

### **Battery Trouble:**

#### **Battery discharged:**

Charge insufficient  
 Battery faulty (too low terminal voltage)  
 Battery cable making poor contact  
 Load excessive (e.g., bulb of excessive wattage)  
 Ignition switch trouble  
 Alternator trouble  
 Wiring faulty  
 Regulator/rectifier trouble

#### **Battery overcharged:**

Alternator trouble  
 Regulator/rectifier trouble  
 Battery faulty

### MODEL APPLICATION

Year	Model	Beginning Frame No.
2016	BR125GG	
2016	BR125HG	
2017	BR125JH	JKABRRJ1□HDA00041

□:This digit in the frame number changes from one machine to another.